

ABSTRACT

SELF-HELP LOW-COST HOUSING CONSTRUCTION
TECHNOLOGY IN BRAZIL

Brazilian cities suffer from an increasing shortage of housing for low-income people. Governamental efforts to eliminate the problem have not been successful, and there is a need for other approaches to the problem. Among these, self-help housing seems to be very promising.

In this study, a self-help low-cost housing technology is presented, and the construction of a 22 m² prototype is described. The development of the technology was based on four parameters: User's participation, use of low-cost materials, modular coordination, and man-equipment interaction.

The technology was developed to provide the basic shelter, which consists of the following sub-systems: foundation, walls, plumbing and electrical systems, floor and roof.

The results obtained in the construction of the prototype encourage the adoption of the approach used, and provide a basis for further development of the technology to ease the housing problem in Brazil.

This study and the building of the prototype
were financed by grants from CNPq - Conselho Nacional
de Desenvolvimento Científico e Tecnológico.

To

Xenia Vruvides

AKNOWLEDGEMENTS

ACKNOWLEDGMENTS

The author wishes to express his gratitude:

In Canada: To Prof. Cedric Marsh for guiding the author with his vast knowledge in building technology; to Prof. Colin Davidson for his inspired criticisms; to Profs. Robert White and Samir G. Mattar for their valuable comments; to Miss Parvaneh Baktash, for drawing the figures for this thesis with patient friendship; to Mr. Robert Asman, for photographing the model; and finally, to Mrs. Daria Finnie for typing the manuscript.

In Brazil: to Prof. Syllas Grazia for his guidance during the construction of the prototype; to Prof. Walter Otto Cybis and Prof. José S.G. Franco, for their support and patience; to Reinaldo R. da Silva for his valuable criticisms; and to Luis Fernando Cybis for his efforts during the construction of the prototype; finally, to Cezar Ramos and his family for their moral support and dedication and enthusiasm to this work.

TABLE OF CONTENTS

TABLE OF CONTENTS

	ABSTRACT	i
	ACKNOWLEDGEMENTS	ii
	LIST OF TABLES	vi
	LIST OF FIGURES	vii
I	INTRODUCTION	1
1.1	Problem Statement	1
1.1.1	Migration	1
1.1.2	Natural Growth of Cities	3
1.2	Present Solution for the Housing Problem	5
1.2.1	The National Housing Bank (BNH)	5
1.2.1.1	Problems Found in Mass Housing Projects	7
1.2.2	Housing Construction Technology Presently Used	10
1.2.2.1	Foundations	12
1.2.2.2	Walls	13
1.2.2.3	Plumbing and Lighting	15
1.2.2.4	Roof	15
1.2.3	Conclusion	16
1.3	Proposed Solutions	17
1.4	Self-Help Advantages and Disadvantages	20
1.4.1	Advantages	20
1.4.2	Disadvantages	23
1.4.3	Conclusion	28
II	CHARACTERISTICS OF A USEFUL TECHNOLOGY	29
2.1	The Usefulness of Technology	29
2.2	The Physical Process of Construction - Definition	29
2.3	Characteristics of a Useful Technology	29
2.4	User's Participation in the Construction Process	31
2.4.1	Design Phase	31
2.4.2	Selection of Materials	34
2.4.3	Construction Phase	35
2.5	Use of Low-Cost Materials	35
2.5.1	Soil-Cement	37
2.5.1.1	Procedure to Select Soil	40
2.5.1.2	Cement Dosage in the Mixture	42
2.5.1.3	Soil Obtainment	43
2.5.1.4	Ways of Using Soil-Cement for Walls	43
2.5.1.5	Other Ways of Soil Stabilization	44
2.5.2	Wood	45
2.5.2.1	Timber in Pole Construction	46
2.5.2.2	Bamboo	50
2.6	Use of Modular Coordination and Standardization	54
2.6.1	Advantages and Disadvantages of Modular Coord.	54
2.6.1.1	Advantages	54
2.6.1.2	Disadvantages	55

TABLE OF CONTENTS (cont'd)

2.6.2	Characteristics of a Sound Modular Design	55
2.6.3	Proposed Modular Grid	56
2.7	Correct Man-Equipment Interaction	62
2.7.1	The State of the Art	62
2.7.2	Man and Equipment Attributes	63
2.7.3	General Procedure to Develop Man-Machine Systems	64
2.7.4	The Housing Construction Problem	66
2.7.4.1	Human Characteristics	67
2.7.4.1.1	The Learning Process: Difference Between Knowledge and Skill	70
2.7.4.2	Equipment Characteristics	71
2.7.5	Five Basic Characteristics	73
2.7.6	Influence of the Context	74
2.7.7	The Question of Precision	80
2.7.7.1	Adaptation to the Material Characteristics	82
2.7.8	The Question of Control	85
2.7.9	Building Sub-Systems Without Clearly Defined Basic Characteristics	86
		87
2.7.10	Distribution of Tasks - the Real Situation	88
2.7.10.1	The Case of Porto Alegre, Brazil	
III	PROPOSED CONSTRUCTION SYSTEM	91
3.1	Selection of Families	91
3.2	Use of Modular Coordination	94
3.3	Design Phase	96
3.3.1	Proposed System	96
3.3.2	Field Results	102
3.4	Construction Phase	109
3.4.1	Location of the House	109
3.4.1.1	Proposed System	109
3.4.1.2	Field Experiment	124
3.4.2	Foundation	128
3.4.2.1	Proposed System	128
3.4.2.1.1	Excavation	128
3.4.2.1.2	Forms	129
3.4.2.1.3	The Use of Soil-Cement	139
3.4.2.1.4	Tamping Procedure	141
3.4.2.2	Field Experiment	144
3.4.2.2.1	Fastening Systems	145
3.4.2.2.2	Productivity	150
3.4.3	Walls	151
3.4.3.1	Proposed System	151
3.4.3.2	Field Experiment	154
3.4.4	Openings	161
3.4.4.1	Proposed System	161
3.4.4.2	Field Experiment	166
3.4.5	Plumbing and Drainage System	167
3.4.5.1	Proposed System	167
3.4.5.2	Field Experiment	172
		173

TABLE OF CONTENTS (cont'd)

3.4.6	Electrical System	173
3.4.6.1	Proposed System	173
3.4.6.2	Field Experiment	180
3.4.7	Floor	184
3.4.7.1	Proposed System	184
3.4.7.2	Field Experiment	186
3.4.8	Roof	187
3.4.8.1	Proposed System	187
3.4.8.2	Field Experiment	196
3.4.9	Surface Treatment	196
3.4.10	Other Finishings	196
3.5	General Considerations	197
IV	CONCLUSION	198
4.1	Analysis of the Proposed Technology	198
4.1.1	Evaluation of Parameters	198
4.1.1.1	Modular Coordination	198
4.1.1.2	User's Participation	199
4.1.1.3	Use of Low-Cost Materials	200
4.1.1.4	Man-Equipment Interaction	200
4.1.1.5	Influence of Materials Characteristics	201
4.1.2	Systems Compatibility with the Basic Parameters	201
4.2	Potential for New Research	202
	REFERENCES	204
APPENDIX	DETERMINATION OF THE SOIL-CEMENT MIXTURE: LABORATORY AND TEST RESULTS	210

LIST OF TABLES

LIST OF TABLES

<u>Table</u>	<u>Description</u>	<u>Page</u>
2.1	Relation of Room Dimensions Provided by the 6M Grid With those Found in Practice	59
2.2	Man and Machine Attributes	63
3.1	Various Options to Combine the Multimodules Adopted	95
3.2	Room Orientations	98
3.3	Dimensions and Corresponding Weight of Forms	130
3.4	Evaluation of the Various Fastening Systems	149
3.5	Time Required to Cast the Foundation Blocks	150
3.6	Time Required to Cast the Wall Blocks	156

LIST OF FIGURES

LIST OF FIGURES

<u>Figure</u>	<u>Description</u>	<u>Page</u>
1.1	Deficit of Dwellings for Low Income People in the State of Rio Grande do Sul	4
2.1	Frequency of Room Dimensions Found in Practice	57
2.2	Location of Walls on the Grid	58
2.3	Minimum Dimensions for Bathrooms	60
2.4	Procedure to Design a Man-Machine System, According to Singleton	64
2.5	Procedure to Design a Man-Machine System, According to Jones	65
2.6	Difference Between Man-Machine Approach and Traditional Approach	66
2.7	Human Characteristics	69
2.8	Equipment Characteristics	72
2.9	Variation of Cost of the Basic Characteristics	77
3.1	Various Architectural Solutions Obtained with the Use of the Multimodules Proposed	96
3.2	Self-Helper Designing His House	99
3.3	Code Used to Represent Openings	100
3.4	Drawing of the House Layout Made by Mrs. Melo	105
3.5 and 3.6	Mr. Ramos Designing His House	106

LIST OF FIGURES (cont'd)

<u>Figure</u>	<u>Description</u>	<u>Page</u>
3.7 to 3.10	Mr. Ramos Designing His House	107
3.11	Drawing of the House Layout Made by Mr. Ramos	108
3.12	Elements of the Aluminium Frame	110
3.13	Self-Helper Copying the Perimeter of the House Using the Aluminium Frame	111
3.14	Location of the First Two Steel Tubes	112
3.15	Aluminium Nodes Placed on the First Two Steel Tubes	113
3.16	Aluminium Tubes Connected to the Nodes	114
3.17	Device Used to Support the Tube	115
3.18	Completion of the Lower Aluminium Frame	116
3.19	Displacements Produced by Loose Fittings	117
3.20	Displacement Produced by the Double Aluminium Frame	118
3.21 and 3.22	Self-Helper Driving the Steel Tubes Into the Ground	119
3.23	Removal of the Aluminium Frames	120
3.24	Design Solution	121
3.25	Sequence Adopted to Locate the Nodes	122

LIST OF FIGURES (cont'd)

<u>Figure</u>	<u>Description</u>	<u>Page</u>
3.26	Change in the Height of the Aluminium Frame	123
3.27	Self-Helper Forming the House Perimeter	124
3.28	Sequence Adopted to Locate the Tubes	126
3.29	Self-Helper Executing Step No. 2	126
3.30	Self-Helper Executing Step No. 3	126
3.31	Self-Helper Executing Step No. 5	127
3.32	Self-Helper Executing Step No. 6	127
3.33	Self-Helper Executing Step No. 7	127
3.34 and 3.35	Excavation of Holes for the Foundations	129
3.36	Forms	131
3.37	Connectors	132
3.38	Spacers	133
3.39	Fastening System Adopted	134
3.40	Overlapping of Foundation Blocks	135
3.41	Form Mounted for the Foundations	136
3.42	Forms Ready to Cast a Foundation Block	137
3.43	Deviation of the Foundation from the Vertical Axis	138

LIST OF FIGURES (cont'd)

<u>Figure</u>	<u>Description</u>	<u>Page</u>
3.44	The Floor Level is Based on the Difference Between the Foundation and the Wall Widths	139
3.45	Use of the Aluminium Frame to Keep the Steel Tubes in the Correct Position	141
3.46	Tampers	142
3.47	Worker Using the Tamper	143
3.48	Bolt Fastening System	146
3.49	Clamp Fastening System	147
3.50	Pin Fastening System	148
3.51	Piece of Wood Used to Extend the Tubes	152
3.52	Block Height and Support to the Forms	152
3.53	Correct Sequence of Casting the Blocks	153
3.54	Sequence of Casting Adopted to Allow Access to the Various Points of the House	155
3.55	Soil-Cement Wall	158
3.56 and 3.57	Soil-Cement Walls Build in the Experiment	160
3.58	Self-Helper Filling a Form Using a Bucket	161

LIST OF FIGURES (cont'd)

<u>Figure</u>	<u>Description</u>	<u>Page</u>
3.59	Location of Windows and Doors in the Walls	162
3.60	Location of a Window Dummy	163
3.61	Door Dummies	165
3.62	Window Frame Located	165
3.63	Three-Dimensional Panel With the Plumbing and Drainage System	168
3.64	Plumbing System	169
3.65	Drainage System	170
3.66	Code Used by the Self-Helper to Represent Electrical Fixtures	174
3.67	Location of an Electrical Box	176
3.68	Electrical System Designed With a Central Box for the Whole House	177
3.69	Electrical System Designed With a Central Box for Each Room	178
3.70	Solution for the Electrical System Presented by the Self-Helper	181
3.71 and 3.72	Electrical System	183
3.73	Procedure Used to Level the Floor	185
3.74	Roof Form	188
3.75	Form Mounted on the Wall	189

LIST OF FIGURES (cont'd)

<u>Figure</u>	<u>Description</u>	<u>Page</u>
3.76	Sequence to Build the Gable Wall	190
3.77	Roof with Cross Wall	192
3.78	Solution for Orthogonal Wall	193
3.79	Ridge Pole Structure	193
3.80	Location of Roof Poles	194
3.81	Bamboo Covering	195

CHAPTER I
INTRODUCTION

CHAPTER I

INTRODUCTION

1.1 URBAN HOUSING DEFICIT IN THE STATE OF RIO GRANDE DO SUL - PROBLEM STATEMENT

1.1.1 Migration

The State of Rio Grande do Sul is located in the extreme south of Brazil, having borders with Argentina and Uruguay. Its climate is sub-tropical and its economy is based on agriculture. However, there is an increasing level of industrialization which brings important modifications to the distribution of the population throughout the state, with a tendency to concentrate in the main cities. This internal migration, which is very characteristic of economies in development, brought to the cities a great number of unskilled labourers who could not be absorbed by industry:

"the preoccupation to create a strong industrial sector in the country generated a process of concentration of investments. As a consequence, we had the uprising of poles of growth and the decontrolled attraction of migration flows, which provoked an increasing housing deficit in the large cities". (1)

In this thesis, a proposal to help solve the housing deficit of the capital, Porto Alegre, is presented. The proposal addresses the problem at the technological level only.

Squatter settlements are directly related to migration flows, and so the characteristics of the people who compose them must be studied to understand their attitude and their expectations about the future.

An increasing mechanization of agriculture, together with a tendency to concentrate the land in the hands of a small group, left the common countryman without work or land. Their only option is to migrate to the city, even without skills or a prearranged job.

D.J. Dwyer⁽²⁾ defined two different patterns of migration: "Step Migration", where the migrating people move from the rural area to a small city, from there to a larger one, and so on. By this means, they can reach the capital or a very large city, but the adaptation process from rural to urban environment happens gradually.

The second way is the direct move from the rural context to a large city. In this case, there is no possibility of gradual adaptation. The migrant does not have time to learn a job or get used to the rhythm of the city, so his chances of failure in the new situation are much larger.

The migrants tend to find jobs which do not require any skills. As a consequence, their income is usually extremely

low. Many of these workers are not even legally hired and do not have a permanent job. These illegal procedures, possible only due to the ignorance and their need to survive in the city, prevent them from using the government's social support (such as medical assistance) or to participate in government housing programs to buy or build their own houses.

1.1.2 Natural Growth of Cities

The large low-income urban stratum is increased not only by migration. There is also the natural growth due to the large difference between fertility and mortality rates in the city. "This combination of 'pre-industrial fertility and post-industrial mortality', to quote Davis (1971), has given the contemporary third world city the greatest rates of natural increase ever found in cities." (2)

Unfortunately, people born in the lower social and economic levels of large cities do not have the chance of a good education, thus increasing the mass of future workers without skills and with very restricted chances of having an improvement in their level of life.

People from both situations described above will form the larger part of the squatter settlement population.

Some will learn a job and increase their salary, but this is not sufficient to improve their living standards, as will be shown later.

Perspectives of the future do not leave any chance for optimism. Indeed, it seems that rural-urban migration and high populational growth will remain the same or even get worse in the near future, forcing the housing deficit for low incomes to increase in time, as shown in the graph below: (3)

--- Maximum
— Minimum

M.V. (Minimum Wage) C\$ 80.00

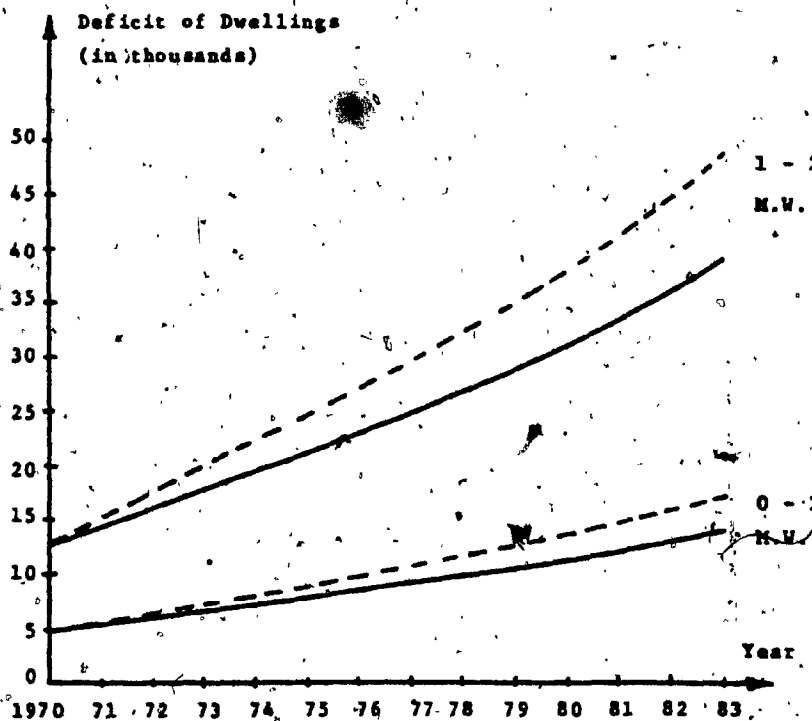

Fig. 1.1 - Deficit of Dwellings for Low-Income People in the State of Rio Grande Do Sul

Many attempts to solve the problem have already been made by the government in these efforts. BNH (National Housing Bank) has played a main role. Its activities must be analyzed to see which are the problems the government confronts and assess the possibilities of success in the future.

1.2 PRESENT SOLUTIONS FOR THE HOUSING PROBLEM

1.2.1 The National Housing Bank (BNH)

BNH is a second line bank which centralizes all the governmental housing policy decisions. Since adequate subsidization of housing is not possible due to the scarce resources of the country, the Bank developed a network to capture the resources it needs. There are basically two sources of funds: the Savings and Loan Passbook Accounts, and an Employee Guarantee Fund financed through payroll deductions.

The Bank was created with the purpose of financing housing for low-income families. However, it was also necessary to finance houses for higher-income people applying higher interest rates, not only to lower the interest rates of mortgages for lower incomes, but also to cover the interest rates paid to the Savings and Loan Accounts.

With time, however, a distortion emerged. The financing of housing for higher-income families became the Bank's main task, absorbing the majority of its resources.

The maintenance of such distortion generated a surplus of capital, which was applied to sectors other than housing.

"From its origins as an institution primarily responsible for tackling the ubiquitous low-cost housing problem, the BNH has evolved into a super-agency unparalleled in Latin America. Its concerns cover a full spectrum of urban affairs: sewage and water networks, mass transit, real estate markets, community facilities, the construction industry, building materials supply, and job training. This broadening of the housing bank's surview has been based partially on a surplus of loanable funds for strictly housing purposes, and partially on a perception of the interrelationships among the many dimensions of the urban environment." (4)

To improve the performance of the Bank in the lower-income sectors, a new low-income housing finance system (SIFHAP) was formed. Basically, it established new relationships between the BNH financing agents and the state housing companies (COHAB), which were to play the main role.

There are three main programs under COHAB's supervision in the state of Rio Grande do Sul:

- a) PLANHAP-RS: It finances the families' earnings between 2 and 5 MW (minimum wage) through a loan payable in 20 to 25 years.

- b) PLOFILURB: This program intends to provide sites and services to families earning less than 2 MW. The house must be provided by the dweller without financial support.
- c) PROCASA: It is similar to PLANHAP-RS, and is aimed at families that already have a site and wish to obtain financial support to build their houses.

BNH also works with other institutions whose main efforts are focused on low-cost housing. They are: the Municipal Housing Departments (DEM HABs), whose main interest is becoming to provide families with the site, instead of the house; the Housing Cooperatives (INOCOOPs), who work with families earning between 5 and 10 MW; other smaller institutions working with specific BNH programs.

1.2.1.1 Problems Found in Mass Housing Projects

In spite of the efforts of such institutions, it is still extremely difficult to reach the lowest income families, even applying lower construction standards. Families earning less than 2 MW have no possibility of financing their houses through a BNH and COHAB program. Even in other programs not related to COHABs, the financial support tends to be utilized by families with incomes close to the upper limits of acceptance due to demand-supply unbalance and smaller financial risks involved.

The lowest income families, therefore, have to solve their housing problem by living in slums under extremely bad conditions, commonly without any services (piped or even treated water, sewage, pavement or electricity).

People who can afford to buy an apartment or a house in a mass housing project do not reveal a high level of satisfaction, either. The problems are not the same, but the main ones are the long time required for the payment of mortgages (in some cases, up to 25 years) which, together with high unemployment and under-employment levels, causes many families to fail to meet their obligations⁽⁵⁾ with the consequent risk of losing their houses.

Low construction quality is also present in many projects. This causes rapid deterioration, worsened by the fact that people do not have resources left for maintenance, since all are being utilized in the payment of the instalments.

Other problems related to the mass housing projects refer to their location. Normally, the projects planned for lower-income people have the worst location, because the land is cheaper in places far away from downtown. In some cases, workers have to travel more than one hour to reach the downtown area, and in some cases only go there

to take another bus which will leave them near their jobs in another suburb. It is not difficult to find someone who spends almost two hours traveling to his job. This implies that they spend around four hours per day traveling in crowded buses. But, more than the lack of comfort, or waste of time, there is the problem of cost. Bus tickets cost more for long distances, and the poorest, who live far away because the land is cheaper, spend a good portion of their salaries on transportation. This can consume up to 20 or 25% of the salary of an unskilled construction worker.

Architectural solutions presented in mass housing projects - more specifically, reduced room dimensions - are not satisfactory. The room size in one such project was 2 x 3 m, or 6 m², far below the minimum recommended (6) (9.3 m² for the first bedroom and 7.9 m² for the second). People believe that the sacrifice is excessive to pay for a house that is too small from the beginning, for over 20 years.

It is not difficult to understand, with all these problems, why low-income people often do not trust the government initiatives related to mass housing projects, preferring to live in squatter settlements, even when the living conditions there are so bad, or, in other cases, why people return to the squatter settlements after having lived for some time in a mass housing project.

Basically, they feel that it requires overall an excessive effort without enough return from it.

12.2 Housing Construction Technology Presently Used

An analysis of the technology available at the moment will provide information on how it contributes to (i.e. fails to reduce) the housing problem of low-income people.

Technology in this context is very important from two points of view: with respect to its diffusion in the cultural heritage and with respect to its cost. Technology is always more accessible to lower-income people when it is transmitted in a way that is integrated in the popular culture, and less accessible when it becomes more sophisticated and requires specialized labour and equipment.

The first case is easily encountered in the so-called "more primitive" cultures, as the South and North American Indians, the Africans and Asiatic groups.

In these cultures, a house is accessible to everybody, essentially because its construction technology is incorporated into the culture, and was developed based on raw materials found in abundance in the place of construction.

Any man can build his house without depending on specialized labour and equipment, and without needing to spend money on costly materials.

In the developed cultures, specialization became a more and more present feature. New materials could be used and new technologies were developed. Construction then became a specialized work. Since the poorest do not have money either to buy the new materials or to hire the specialized labour, and because in these cultures the primitive technologies have been abandoned in the past, these people are now incapable of providing their own houses. Ken Kern⁽⁷⁾ understood this problem very well:

"It is unquestionably our drive towards specialization (stemming from a basic failure on the part of our whole educational system) which is primarily responsible for modern man's inability to provide directly his own shelter needs. Despite this trend the owner-builder home can be an economical as well as an aesthetic success. It has been so for centuries for millions of families, and it continues to be so today. Furthermore, the process of building one's home can become one of the most meaningful and most satisfying experiences in one's life - as, indeed, it should."

Contemporary construction technology in Brazil will now be analyzed, bearing in mind the considerations discussed above.

In Rio Grande do Sul, the technology used in construction is based on a combination of materials and components obtained from different levels of industrialization, and require different levels of labour specialization, then becoming more or less accessible to the people.

1.2.2.1 Foundations

There are basically two kinds of solution for foundations. The first one is the direct foundation wall footing or short columns directly laid on the ground, normally utilizing stones. This technology is available to most of the people, because it requires little specialization. However, material is expensive and some people prefer to build short brick columns for wooden houses.

The location of the foundations in the ground (the foundation layout) is a bottle-neck in the construction process and normally requires a specialized person. The reasons for such problems will be studied later. For now, it is enough to note that this technology requires a certain level of education, not always present, and a certain level of intelligence to apply in each specific situation the principles learned. It is not a coincidence that only the foreman is allowed to set the foundation layout. This work

(at least in Brazil) is a reason for pride when it is well done. Indeed, it is one of the most complex and sophisticated operations, and it is one of the last to be learned by the construction workers. In a few words, this foundation technology requires a knowledge not available to everybody.

File foundations and drilled belled piers are also commonly used foundation technologies. However, they require special equipment, and are executed only by specialized companies.

1.2.2.2 Walls

Walls are normally constructed of bricks or wood boards. Another technology, using earth either as adobe or as plastic covering a bamboo or wood lightweight frame, was abandoned in favour of the first two. It was used in the cities until five decades ago for internal partitions.

The brick wall technology is widely disseminated among low-income people, mainly because many of them have worked in the construction field as masons or assistants. However, probably the main reason to choose this technology is the status it provides to the owner if compared with a wooden house.

Unfortunately, people without experience in the field do not achieve either a good quality or a reasonable productivity with this technology. The difficulties remain in activities such as levelling, plumbing, measuring and squaring. Time and practice are required to develop the ability to provide precision to the walls. However, in many cases, this practice can be exercised only in one's own house. This situation is extremely frustrating for the people without shelter.

Wooden wall technology presents less problems, since the boards can be easily fastened on the framework of the house (which, however, must have been correctly plumbed, levelled and squared). However, the problem is not solved; it only becomes easier, since now there is a smaller number of larger elements to be precisely located. Also, wooden houses provide inadequate thermal comfort in the winter, as well as in the summer (with internal temperature varying from $+5^{\circ}\text{C}$ to $+30^{\circ}\text{C}$), since the walls are composed of one layer of boards (commonly 2.0 cm thick). There are also problems related to maintenance, which is becoming extremely expensive, forcing many owners to abandon correct maintenance procedures.

1.2.2.3 Plumbing and Lighting

Plumbing and lighting are definitely specialized tasks at the present technological stage. The plumber or electrician has to read a drawing and translate the solutions presented there to the real world.

In lower-cost housing, the user has neither the money to hire specialized persons to design and execute these systems, nor the knowledge and ability to do it by himself.

The problem is commonly solved by hiring a self-taught person, with the risk of getting a malfunctioning and dangerous system.

1.2.2.4 Roof

The roof is one of the most difficult parts of the house to build; it must be impermeable to water and structurally stable. A good roof should also present some thermal insulation. The roof structure is normally provided by a wooden frame, made by a carpenter. Commonly, the covering material is clay tiles or asbestos-cement sheets, which can be laid by unskilled labourers.

If the roof is a concrete slab, the work becomes even more specialized. This implies an increase in the

roof cost. This solution is too sophisticated and expensive to be used in a low-cost housing project.

Wooden and metal windows are produced in independent factories by specialized labour in order to be competitive in the market and keep a reasonable level of quality. The owner has to buy these windows at the market price, and in a low-cost house the cost of openings can go up to 17%⁽⁸⁾ of the total cost. Since many people cannot afford such expenses, it is common to find curtains replacing internal doors and pieces of wood nailed together replacing the windows.

1.2.3 Conclusion

It is important to understand that the lower-income people do not have a satisfactory solution for their housing problems. They cannot buy a house offered on the market due to economic constraints, as shown in the analysis of the BNH's activities. Also, they cannot utilize the current building construction technology because it requires specialized labour. The result is an enormous effort on the part of these people to build their houses the best they can, paying for specialized labour as much as they can and buying the best materials their constrained budget permits them to do. Yet, the product of such effort is, quite often, a slum house.

1.3 PROPOSED SOLUTIONS

Many proposals have been presented to solve the housing problem. They come from practically every part of the world and are based on different approaches, requiring different degrees of transformation in the receiving society, if they are to achieve their original goals. For those who require the deepest changes, only an economic organization with the power associated with some international status, coupled with a greater mutual comprehension, would permit the achievement of some result. (9) Another current of thought is that, it is enough to transform the internal social and economic structure of the problem ridden country itself. (9)

United Nations consultants generally emphasize approaches requiring from the government a certain level of consciousness about the problem. They ask for a larger effort to solve the problem, enlightened by a clearer view of it. (9)

Some thinkers propose complete government responsibility to solve this problem, and argue that it should provide for all the housing needs of the population, perhaps forgetting that they are talking about countries with scarce resources.

Others support the view that lower-income people should provide their own shelter through government-oriented programs. This seems to be a more reasonable approach, since it considers more realistically the economic situation, not only of the unsheltered masses, but of the country as a whole. As a matter of fact, squatter settlements are themselves a product of spontaneous self-help activity.

The basic arguments against the use of an approach other than self-help are:

- the pragmatic recognition of the government's incapacity to provide housing for all who need it, at an affordable price. In Brazil, this incapacity was admitted by the president of the BNH, who said that the intention of the Bank is not to eliminate the housing deficit, but to avoid its increase;

- users' dissatisfaction when living in government sponsored housing projects. This kind of approach proved to produce a housing solution far below the users' expectations;

- the users' monetary problems that arise with the purchase of a financed house: there is a decrease in the level of living for an excessively long

period (25 years), and the lack of stable employment frequently impedes the payment of the instalments on time.

Quite frequently, these two causes force the users to abandon the program or a repossession of the house by the sponsor.

All of these problems reinforce the belief that a self-help attitude is the only manner in which these people have to satisfy their housing needs.

There are, however, many different proposals on how to provide people with the necessary support for a self-help attitude. The various solutions will be presented according to a classification proposed by Reinaldo Roesch da Silva: (10)

- a) "Spontaneous" Self-Help System: the user controls the majority of the decisions to be taken;
- b) "Aided" Self-Help System: the user established his goals according to a series of options and pre-established rules;
- c) "Oriented" Self-Help System: the user participates in the construction process with his labour, but he cannot interfere in the decision process in a significant way.

1.4 SELF-HELP ADVANTAGES AND DISADVANTAGES

There are some advantages and disadvantages in a self-help process, which are worth analyzing:

1.4.1 Advantages

Construction costs are smaller for the owner-builder.

The savings come essentially from the management and financial costs, and the labour cost. Of course, the amount of savings depends on the kind of self-help and the context in which it is carried out.

The savings come from the replacement the dweller makes of the money he would spend hiring skilled labour or someone to manage the construction process, by time he spends constructing and managing the house by himself. This reduction of costs is described by William C. Grindley. (11)

"Field work tells us that the owner-builder method of planning, construction and maintenance is efficient. The first major savings - a conversion from money to time - occurs in administration and management. Since an owner-builder is, by definition, one who administers and manages the construction of his house, this very heavy liability is transferred into a demand on leisure time, which the owner-builder will happily give up (if, in fact, he does not view building his own house as recreation or therapy) for the saving in cash it will mean for him.

"An owner-builder's savings on construction costs range from 22 to 53% of the construction cost of developer-built houses. It should be emphasized that these savings do not include the equity earned on the actual labour an owner-builder may invest in his house. Selective purchasing of materials and favourable arrangements for construction help (donation of time by friends, also use of moonlight craftsmen, and so forth) also significantly reduce costs."

Maintenance costs are reduced. Maintenance costs vary fundamentally with the quality of the house and the care the user takes of it. The quality of the house, in its turn, depends on the quality of materials used and the quality of labour. The well-oriented owner-builder tends to produce a house of quality at least as high as if it were built by a professional, since he compensates his lack of skill by much more responsible and careful work. Also, he only buys materials he believes are good enough to last for a long time. In other words, the owner-builder is the most perfect quality controller of his work and materials acquisition. With respect to the maintenance, no tenant could take more care of the house than the owner-builder. This is partially due to his involvement and sense of responsibility developed in the construction phase. Also, the skills and knowledge he acquires at that time help him during

the occupancy phase. The importance of a self-help attitude in the maintenance of the house is expressed by Eryan Bueneman. (12)

"A person who has built his own home has a stake in and an appreciation for that home. An individual's involvement in the construction process results in a feeling of responsibility for his home; a responsibility which can preclude the development of management problems after occupancy."

The positive feelings of pride and satisfaction are commonly much higher in a self-help process than in a buying process. The self-help approach in construction is not important to the owner only as an economically adequate solution. There are many feelings that come along with it. This point of view is shared by Edward Allen. (13) Two of the most important are the feelings of pride and satisfaction for what has been built by one's own hands according to one's own planning and design.

The author has noticed the human need to transform and adapt the surrounding environment according to his needs and preferences. Such need is more fulfilled in a self-help housing process.

The self-helper can build his house according to his capabilities and availability of capital and time.

Since the self-helper provides his own work, he can stop and restart the construction activity as many times as he needs. He does not have to worry about hiring and firing people with all the embarrassment that this brings.

Also, he can capitalize his resources, buying construction materials which will not depreciate with time. Actually, this is a very common procedure among Brazilian self-helpers.

The self-helper capitalizes his leisure time. Due to the housing shortage, dwellings built by self-helpers are wanted by people with better financial conditions. When selling the house (if they so decide), they are selling their work, improving their economic situation.

1.4.2 Disadvantages

The Puerto Rican Planning Board carried out a self-help experiment ⁽¹⁴⁾ from which some conclusions were drawn. This institution has found various problems related to their experiment. It is interesting to note, however, that such

problems - or disadvantages - are not inherent to the self-help approach and can be overcome. The disadvantages are listed below:

1. "Too long a time is required to build self-help houses (an average of six months to construct about twenty houses).
2. To construct the dwellings, under a cooperative arrangement with small groups that consist of fifteen or twenty families, is difficult owing to the delicate job of orientation.
3. An organization of engineers, inspectors and administrative personnel is required in the agency to administer the program.
4. The cost of these dwellings, especially in the rural areas (\$350.00) does not reflect the true costs, since this figure ignores the cost of the land in the rural community, the salaries of the technical and administrative personnel, and the cost of future improvements to be made in the rural communities to fulfil the government philosophy of providing essential services.

5. The need to acquire and operate costly construction equipment.
6. Construction by the families is imperfect because of the lack of experience.
7. No great economies or efficiency in construction is obtained, since the modern techniques of mass production are not used."

This list of problems can be increased by including the following obstacle to the use of the self-help techniques, as mentioned by Charles Abrams: (15)

"Reliance on industrial workers to learn building crafts and to find time and energy for building will generally prove disappointing. The forty-hour week is still a long way off in many places. Selection of those with common objectives and free time is essential. But this tends to make each project a special case and such benefits fail to accrue to the bulk of the working population."

Furthermore, the time spent in learning skills is a costly and time consuming task: costly, because it implies an administrative and teaching cost proportional to the number of skills which have to be learned and to the quality required; time consuming, because to learn such

skills is not a question of days, but months. And all this learning process will be useful only for the construction of one's own house.

Self-help housing presents specific problems when its organization is based on mutual-aid groups.

The decision to participate in such programs is the most important one of the whole process, and the owner must be absolutely clear about what he is entering into. (16) He must be sure that this is the right time to do so. However, government agencies in charge of creating and assisting such groups normally do not rely on owners' capacities of analysis; groups are formed through a selection of families who intend to join the program. This selection is intended to select those who are motivated enough to carry out the project to its end, then providing each family with a reasonable stable group. However, problems exist.

Due to the considerable employment instability, many low-income people pass through unemployment or under-employment periods, with practically no savings to deal with such situations. So, investments that would normally be applied in housing have to be deviated to more urgent needs like food, medicine and clothes. Such facts allow

one to anticipate that two things might quite possibly happen. First, the individual himself is unemployed and is obliged to drop from the group. Secondly, other persons drop from the group, forcing the individual to abandon the program due to the absence of a group structure to support him.

Even if the owner-builder obtains a loan for his construction expenses, he still may have financial problems during the amortization period. The common procedure adopted by financing agents in Brazil is to take the property back after a three-month delay in instalment payments. Changing this rule is considered to be a stimulus for bad payers.

Obviously, this repossession is even worse than stopping the construction, because the self-helper has his house already built.

All these considerations lead to the conclusion that the self-helper should be provided with as much flexibility as possible to start building his house. The ideal situation would be to enable him to take his decisions individually without depending on anyone else. Oppositely, the larger the program and the more people he depends on to start his housing process, the more artificial and "forced" this starting point will be, with higher chances of failure.

After the analysis presented above about the importance of user independence with relation to a large program, it is necessary to analyze the importance of this participation in the various phases of the housing process.

1.4.3 Conclusion

We have presented both the advantages and disadvantages of a common self-help proposal. It is necessary now to develop techniques which can utilize the advantages and eliminate - or at least minimize - the disadvantages. Such techniques will be proposed in the next chapter.

Management procedures and land and urban problems are beyond the limits of this thesis, which is concerned with the physical process of construction.

CHAPTER II

CHARACTERISTICS OF A USEFUL TECHNOLOGY

CHAPTER II
CHARACTERISTICS OF A USEFUL TECHNOLOGY

2.1 THE USEFULNESS OF TECHNOLOGY

In essence, housing technology is useful in direct relation to its capacity to provide the attainment of a dwelling responsive to the user's needs and expectations. This relationship should be kept in mind during the development of such technology.

2.2 THE PHYSICAL PROCESS OF CONSTRUCTION
DEFINITION

Technology is applied during the physical process of construction, which can be defined as the transformation and combination of materials into the final project (the building itself), through one or more phases. These transformations are obtained by the combined effort of man and equipment.

2.3 CHARACTERISTICS OF A USEFUL TECHNOLOGY

Since the intention of this research work is the development of a technology which enables self-helpers to

carry out the physical process of building, it is necessary to analyze each part of the above definition and to propose solutions that will utilize the advantageous characteristics of self-help systems. The following aspects deserve special consideration:

- The final product must be built according to the needs and expectations of the self-helper. Thus, it is not only necessary to provide for his participation in the construction phase itself, but also in the design and selection of materials.

- Certain technologies are developed only after the materials to be used by them are specified (eg.: soil-cement). The intention of this research work was to predefine materials only for those sub-systems which are part of the basic shelter. Such materials have to be inexpensive and, at the same time, must provide the house with satisfactory structural, thermal, aesthetical, safety and functional performance.

- The use of modular coordination is important, since it facilitates the standardization of equipments and procedures.

The combined man-equipment effort has to be studied. This study will show how each of them has to interact with the other to provide the best possible product with minimum effort and cost. The interaction between man and equipment will be established based on their inherent characteristics.

Finally, it is necessary to take into account the characteristics of each material, in order to transform and combine them more efficiently.

2.4 USER'S PARTICIPATION IN THE CONSTRUCTION PROCESS

2.4.1 Design Phase

The participation of the dweller in the design phase is essential, since the needs of the family will be satisfied only if its members are able to express them, preferably without getting involved in technological problems.

It is necessary to determine to what extent this participation is possible and useful, and what is the role of the architect in this new interaction with the user.

Mass housing projects commonly standardize the possible housing solutions, offering only a few different

layout options. Such a procedure is justified by the economy of scale obtained.

An entity called "the average man" (1) is used for the determination of which solutions should be adopted. Unfortunately, the number of families that will have their needs really satisfied is very small, being only those who have needs close to the adopted average.

Indeed, the needs of a family are as varied and different as are the relationships existing between the members of each family multiplied by concepts and expectations of each member of the family with respect to the house to be built multiplied by the different economic conditions of each family when building the house. This point of view is expressed by Anne Vernez-Mondon, based on her observations at Les Marelles: (2)

"A second lesson from Les Marelles concerns the issue of housing standards. The broad differences found in dwellings that could be considered as belonging to the same conventional categories are striking: for example, the four apartments averaging 117 gross square meters (including the terrace space), cover a range of one to three bedrooms. Within this sample, the sizes and types of kitchens, their relationship to eating and living spaces are so varied that they defy generalization and point to the actual variety of needs, tastes and values prevailing in so-called homogeneous segments of the housing market. On the basis of these examples, one must seriously question the established norms and standards that are widely applied in housing today."

It seems clear that users must participate in design decisions. The planner must find a way to let them express their needs without having special knowledge or ability.

Commonly, users' participation in design is restricted to the dwelling itself, as in Les Marellles, the "supports" proposed by Habraken,⁽³⁾ or an experiment with low-income families in Mexico City.⁽⁴⁾ However, users' participation can be very worthy, as shown in an Argentinian experiment, conducted by a research group from the Universidad Del Chaco,⁽⁵⁾ where the information provided by the dwellers helped to plan an urban structure which reached their goals more nearly than if this planning were executed only with the concepts normally used in urban planning.

At the single dwelling level, the above systems present a limited freedom for users' expressions of needs. There are some parameters that have to be kept unchanged: the modular grid, the thickness of the walls, and sometimes the plumbing system.

Normally, users are allowed to define the size of and interrelationships between rooms. It seems that the use of a 1:10 model of the house is the easiest and the most approved way for users to express their needs. This model includes walls and furniture, which works as a reference for dimensioning the rooms.

Working together with the user, the architect plays the role of counsellor and source of information. He must not impose any solution, but rather explain the consequences of the solution adopted and the aspects which the users must take care of. So, if the user decides to adopt a solution, he is aware of the consequences that decision will have.

2.4.2 Selection of Materials

Users should be given the possibility to choose the materials and elements which are not pre-defined by the technology to be used. This would provide greater satisfaction and would utilize the different capabilities they may have to obtain different materials.

The author's experience has shown that different users find different conditions to buy the various materials. This potential should be used to increase the users' purchasing capacity.

These different conditions come with the purchasing of recycled materials from demolished buildings, and new surplus materials from other buildings.

It is also important to consider the self-helper's previous experience. It seems clear that it would be better if the user could utilize a material with which he has already worked.

2.4.3 Construction Phase

User participation in the construction phase is very important to minimize costs. This importance comes from the amount of time and money consumed in this phase.

However, the development of a technology that could be absorbed by the owner-builder cannot depend on any skill, since it has to be accessible to those who have not had previous experience in building construction. This problem will be analyzed in depth later. Now, it is enough to have clearly in mind that this characteristic must be present in a technology that is pertinent for this application.

2.5 USE OF LOW-COST MATERIALS

Materials that will be utilized to build the basic shelter have to be defined for the development of appropriate technologies. Such materials must have certain characteristics to be successfully applied. The requirements are that they:

- Be Resistant to Rapid Deterioration. The problem of deterioration is more important when the owner does not have much money either for maintenance or for replacement of deteriorated materials. When poor quality materials are used, the tendency observed in existing low-income housing projects in Brazil is to have the owner abandon maintenance activities, provoking an even faster building deterioration. (6)

- Be Acceptable by the Users. Materials acceptance by the users is essential, due to the importance of psychological aspects in self-help construction. This acceptance may even be transformed into an enthusiasm that will help the user to overcome future problems related to the materials. On the other hand, his lack of confidence will bring a real risk to the success of the process, since every problem will serve to reinforce the owner's idea that he is wasting his time and money.

- Be Easy to Utilize. The use of materials will be made easier if no skill or special knowledge is required for its handling. It is also interesting to use materials which do not require special and expensive equipment.

- Have Simple Quality Control. This requirement is closely related to the one above. The reasons are

the same, the easier the control of the material, the easier its utilization. If the material requires sophisticated equipment or a long time for testing its quality, the owner may avoid quality control, with possible bad consequences.

Have Good Performance. This is somehow too vast a characteristic. Depending on their application, materials should be sound and heat insulators, present reasonable impermeability, have good resistance to compression, tension, dynamic loads, impact and abrasion, etc.

These are the characteristics which should be present in materials. Previous works (7,8,9,10) have exhaustively recommended two materials as deserving special attention: soil-cement and wood. Each of these will be analyzed in order to establish to what extent they can be useful as low-cost materials.

2.5.1 Soil-Cement

Cost. Soil-cement is one of the cheapest materials to be found, basically because the major part of it - the soil - can be obtained directly by the owner-builder

without any cost. The only cost is that of the cement, added to stabilize the soil. Its cost is around one-quarter of that of a masonry wall with similar characteristics.

Deterioration. If the mixing of the materials is well-done, there is no risk of fast deterioration to the soil-cement wall. There are, indeed, several examples of soil-cement houses that have been kept without major maintenance problems for several decades in many places around the world. (7)

Performance. Walls shall be analyzed in terms of acoustic, thermal insulation, moisture penetration, structural performance, resistance to impact and abrasion.

In terms of thermal insulation, the soil-cement wall presents values which are similar to a brick wall. Experiments in Brazil (11) provided the value of $K = 1.83 \times 10^{-3} \frac{\text{cal. cm}}{\text{C. cm}^2 \cdot \text{s}}$ at 60°C. Some variations are due to the percentage of voids in the material. This percentage decreases with compaction, also depending on the soil granulometry. Water permeability depends on the percentage of voids and on the granulometry. The author's experience has shown that in any

case, it is necessary to apply a protective painting on the outside of external walls.

The structural characteristics of a soil-cement wall depend basically on the percentage of cement added to the soil. It can be set at 6% for the soil found in Porto Alegre, Brazil. This cement percentage provides an average compression strength of 2.8MPa. The Bureau of Standards of the U.S.A. published a report on structural, heat transfer and water permeability properties of various earth-wall constructions. The strength test results were presented in THE OWNER-BUILT HOME from Ken Kern⁽¹²⁾.

- Facility of Use. Soil-cement is one of the easiest materials to work with, independently of the construction system proposed (small blocks or rammed wall). This facility is due to a series of factors. Some of the more important are:

- no requirement for sophisticated equipment or care to handle the material;
- no requirement for special facilities for material storage;
- no requirement for special training of labour to use the material.

- Acceptability by the Users. The material is well-accepted due to the users' past experience with similar materials. In the State of Rio Grande do Sul there is a traditional way of building using earth and wood; there is also the frequent use of adobe construction, mainly in the countryside.

- Quality Control. The quality control of soil-cement is extremely easy. It does not require expensive equipment or special skills, or even great knowledge by the person charged with it. Indeed, this control can be carried out by the self-helper. There are some procedures that provide good information about the quality of the material to be used. (7) These procedures will be described below.

2.5.1.1 Procedure to Select Soil
Granulometry Curve

The Granulometry Curve is fundamental in the use of soil-cement. A high percentage of clay would require too much cement to stabilize the soil, while an excess of sand would also bring about some problems, since there would be no clay to fill up the spaces between the sand grains. The following soil characteristics are proposed: (13)

a) Grain Size Distribution Limits:

Maximum Size : 7.5 cm
Passing No. 4 Sieve : at least 50 percent
Passing No. 40 Sieve : 15-100 percent
Passing No. 200 Sieve: not more than 50 percent

b) Plasticity Test Limits:

Liquid Limit : not more than 40
Plasticity Index : not more than 18

c) Organic Content:

Upper Limit : 2%

Water addition also has to be controlled. Normally, the value which produces the maximum density of compacted material can be adopted.

The best way to obtain the information is through laboratory tests. However, extremely simple field tests can also be carried out by anyone without any problem. These field methods are described in several publications. Ken Kern ⁽¹²⁾ described one of these methods, which provides basic information:

"The simplest test is merely to pick up a handful of dry earth and to rub it between the fingers. Sand particles are gritty to the touch, while silt and fine particles adhere closely to the skin and have a silky feel."

Clayey soils should be avoided. In another field test described by the same author: (12)

"In another field test for determining exact sand-clay proportions, fill a one-quart mason jar one-quarter full of the soil sample. The earth should first be screened through a No. 4 sieve, 6 squares per inch. The jar is then filled with water, and a spoonful of common table salt is added to speed up the settling of the clay. The jar should then be agitated thoroughly and allowed to settle for one hour. The sand and clay will settle in successive layers, the bottom layer being sand and the top layer being clay. Measure the height of the sand and divide it by the total of soil settled in the bottom of the jar. This will give the percentage of the sand in one's sample."

The percentage of sand should be between 50% and 85%.

2.5.1.2 Cement Dosage in the Mixture

The cement percentage depends on the type of soil used and the desired final strength. Clayey soils require a higher percentage of cement, since the volume of clay to be stabilized is larger. So, a sandy soil is more economical. There must be, however, some amount of clay to fill the spaces between the sand grains.

In sandy soils, the percentage of cement can be as low as 6% in weight, while in clayey soils it can go up to 12% in weight to obtain the same resistance. In practice, the percentage of cement is measured by volume, using appropriate boxes.

2.5.1.3 Soil Obtainment

To obtain soil is not as easy as it would seem at first glance. This is due to three main factors: soil granulometry, volume of soil to be used, and the need to use soil without organic material. Due to this last factor, it is necessary to excavate the ground and remove the upper layer. This layer can be as deep as 1.0 meter. Soil containing organic material is characterized by the colour (dark soil) or by the presence of roots.

The volume of soil required may be very high. For instance, the volume of soil is about 25 m^3 for a wall 20 cm thick. This represents a hole of 5 x 5 m, 1.0 m deep. Adding the layer which has to be removed to avoid organic material, the result is a hole of 5 x 5 x 2 m. It seems obvious that, for the majority of cases, the soil cannot be obtained from the user's courtyard. It must be obtained from another place, preferably from a public place which has to be levelled near the construction site.

2.5.1.4 Ways of Using Soil-Cement for Walls

There are two basic ways of using soil-cement: small blocks and monolithic wall. Both ways have advantages and disadvantages. The basic difference between them in terms

of cost refers to the amount of cement to be added to the soil. Small blocks require a greater percentage of cement, since the entire wall becomes less resistant due to the greater number of joints and localized compression forces across the joints.

The relationship between the resistance of laboratory test specimens and the actual wall is: ⁽¹⁴⁾

$$\text{Blocks} \quad R_W = 0.28 R_L$$

$$\text{Monolithic wall} \quad R_W = 0.55 R_L$$

where R_W = resistance of the actual wall

R_L = resistance obtained from laboratory test specimens

2.5.1.5 Other Ways of Soil Stabilization

There are other ways to obtain soil stabilization. Two of the most common are the addition of bitumen or lime to the soil. Bitumen is mostly used when small blocks are to be used. The bitumen makes a thin film that surrounds the clay particles, thus stabilizing the soil. This process is more suitable when clayey soils are used.

Lime as a stabilizer is used alone or with the simultaneous use of fly ash, which takes the place of clay and silt when the soil is too sandy. The compressive strength of the mixture of soil with the lime increases more slowly than when cement is used.

2.5.2 Wood

It is necessary to divide the analysis into two parts, the first one referring to timber such as pine and eucalyptus, and the second to bamboo, which is an excellent material for certain uses.

2.5.2.1 Timber in Pole Construction

Timber will be analyzed according to the criteria used for soil-cement.

Cost. The cost of poles for structural purposes is much lower than the cost of other materials, such as reinforced concrete, steel, or even lumber. The low cost justifies the use of wooden poles as construction material for low-cost housing. In Porto Alegre, an untreated log 5000 x 100 ϕ mm costs about 0.75¢, or 0.15¢/meter.

Furthermore, if adequately planned, the cost of timber in a large housing project could come close to zero. Since it is utilized practically in natura, it seems feasible to organize a housing project in which one of the points would be the planting of trees to provide these poles.

If used for light structures, like roofs with short spans, these poles could be obtained from fast-growing species. Trees of a suitable diameter could be cut in 2½ or 3 years.

- Deterioration. Deterioration is always considered one of the weakest features of wood. However, if certain procedures are followed, the wood structure will last as long as the entire house. When wood is used, three procedures should be observed:

- it should be chosen from a wood with high natural resistance to fungi and insects, mainly if poor maintenance is expected;

- the wood diameter should be chosen before its use: "if untreated poles are to be used, the effective diameter should be taken as the diameter exclusive of sapwood, as sapwood is liable to decay"; (9)

- the design should always help the preservation of the timber: "ventilation should be provided to ensure that any moisture which enters into the wood dries out before any decaying organisms can develop". (9)

- Structural performance. Wood has good resistance to compression and tension, while being a light material. Also, "the round pole possesses a very high proportion of the basic strength of its species because knots

have only half the effect on the strength of naturally round timbers compared with sawn sections.

"Generally, poles could be very easily erected and provide a rigid framework to support the roof and walls and, if necessary, part of the floor as well." (9)

As can be seen, poles present a good structural performance if adequately used for housing framework, and more specifically, for roof structure.

Other performances. The susceptibility to fire hazard is diminished in pole construction, if compared to light frame structures. This is due to the larger cross-section used in pole construction, which allows a structure with fewer elements. The larger sections also last longer when exposed to burning due to greater volume/surface ratio.

Facility of use. Pole construction is more appropriate than lumber for use by unskilled labour. This is due to the smaller number of pieces which have to be handled, and to lower precision requirements for cutting and fitting.

There are other advantages to wood: it does not pass through any chemical transformation when it is being used; it does not require either special facilities for storage or special equipment; abilities required to work with wood such as nailing, sawing, etc. can be easily learned, and indeed, most people already possess them.

- Acceptability by the users. Since wood is one of the oldest, and most widely known and used construction materials, there is no problem of acceptability.

• Pole structure could give a more rustic impression, and some self-helpers may have a certain resistance to it. But, since it will be utilized in the roof and covered later, this problem, if existent, is minimized.

- Quality control. The only quality control required is related to the diameter of the poles used, since it comes ready from nature. If the wood is treated, the quality of this treatment should also be controlled. However, these are not difficult tasks and could be performed by the owner.

2.5.2.2 Bamboo

- Cost. Planting costs are very low, since bamboo does not require special equipment or very fertile soil. The growing phase does not require special and constant attention either. Equipment used to process the bamboo after cutting does not contribute an important part of the cost. Preservation against insects and fungi is the main cost factor in the use of bamboo.

- Deterioration. Most of the bamboo species are very sensitive to insect and fungi attack. The lifetime of untreated bamboo is very short: "bamboo posts embedded in the ground are destroyed in six months to two years. Bamboo stored above the ground gave, in tests, a useful life of 22 to 41 months. Bamboo, under cover and not in contact with the ground, may last from two to seven years." (8)

- Structural performance. The strength of bamboo "varies with species, age, growth conditions, moisture content, disposition of nodes, and position along the culms". (8) It presents a high tensile strength which, however, cannot be fully utilized in bamboo-reinforced concrete, since it "would fail in shear long before

its full tensile strength was developed".⁽⁸⁾ For design purposes, the modulus of rupture is adopted. It "varies from 900 to 1700 kg/cm² or an average of 1300 kg/cm²".⁽⁸⁾ "The compressive strength parallel to grain ranges from 315 to 725 kg/cm² or an average of 520 kg/cm²".⁽⁸⁾

The above values show that bamboo can be used as a structural element, alone, or combined with concrete, "as reinforcement in flat as well as sloped roofs, beams, stairs, cantilevered porticos",⁽¹⁵⁾ and other situations.

Water permeability. Large-diameter bamboo can be used as roof tiles, adopting 30° as the minimum pitch. Such roof "can be made completely watertight".⁽⁸⁾

Facility of use. Bamboo can be processed, cured and used without requiring sophisticated equipment. The processing of bamboo consists of cutting and splitting the clums. Bamboo "cutting is generally done by hand with axes, machetes or saws".

Splitting is done with very simple devices, since bamboo already has such a tendency. Generally speaking, any object which can expand a crack in the clum can be used to split it.

The use of bamboo as roof tiles is extremely easy, since it consists basically of superimposing the halves previously prepared. The only restriction refers to the use of nails. Most of the bamboo species will split if large nails are used. Small nails can be used, but the best solution is to have the elements lashed to each other. Horizontal joints are simple, but joints for vertical elements are more sophisticated. In any case, this is a problem in using bamboo in roofs.

The use of bamboo in reinforced concrete is a more sophisticated work. Only well-oriented and supervised workers can use it, which limits its use in self-help housing.

The use of bamboo is also limited by the need for preservative treatments. The simplest methods are: water leaching and coating (not efficient for exposed inner walls). Chemical treatment is more

effective, but also more dangerous, and its use should be adopted only when safety procedures are ensured.

- Acceptability by the users. In Brazil, bamboo has been used in fences, lightweight roof elements and as reinforcement for mud plaster walls. It is also used as water pipes in rural areas. These varied uses made this material well-known, mainly by the low-income people, which increases the possibility of acceptance for new uses, especially if these prove to be more economical than traditional elements.

- Quality control. The use of bamboo as a structural element requires constant supervision and control, which makes its use only possible in a well-organized housing project.

For roofs, attention has to be paid to fastening procedures, and to the integrity of elements used (to avoid partially splitted clums). These tasks, however, can be performed by the self-helpers without much training.

2.6 USE OF MODULAR COORDINATION AND STANDARDIZATION

The use of modular coordination has its importance revealed in three stages: during the design and production of the equipment, during the design of the house, and during the use of the equipment in the construction process.

Modular coordination should be incorporated into the development of technologies from the preliminary stages, so that it can exercise its influence and bring benefits from the beginning. Evidently, the design will influence the housing solutions.

"Design forms an important part of the preparation for construction and can influence not only its quality, but also the method of construction, productivity of labour and construction cost. It is possible to use design to create prerequisites for rationalization and the industrialization of construction. Standardization and design influence the quality of construction". (16)

2.6.1 Advantages and Disadvantages of Modular Construction

2.6.1.1 Advantages

- Cost of equipment (eg., wall forms) is reduced. Since a few different sizes are used, the same equipment can be used several times, even by different users, who adopt the same modular grid.

- Technology is more easily learned and adopted. The small number of different activities facilitates the learning process.

2.6.1.2 Disadvantages

- Limitation of freedom in the design process. "This reduction of freedom is seen by some authors⁽¹⁷⁾ as a need for "creative discipline" which, nevertheless, does not mean uniformity or monotony".

2.6.2 Characteristics of a Sound Modular Design

Marcel Franssens⁽¹⁸⁾ emphasized the need to base design on a detailed observation of the real world. George Banz⁽¹⁹⁾ differentiated between "oppressive" and "non-oppressive" modularity. The second kind would be the answer to the problem of the reduction of freedom in modular design.

To obtain a non-oppressive modularity, we established three conditions to be met:

1. All industrially-produced modular components must be definable in human (experimental) terms and not merely in terms of production process.

2. Modules must be diverse enough to be able to accommodate all functions they are expected to serve.
3. Modular design must be open-ended so as to permit the occupant of the "modular environment" any desired elaboration of spatial arrangements and architectural form acceptable to the community".

Other characteristics are:

- minimum equipment diversity;
- matched to ergonomic premises with respect to equipment size and weight.

2.6.3 Proposed Modular Grid

The figure below shows the results of a survey about the size variation of certain rooms (18).

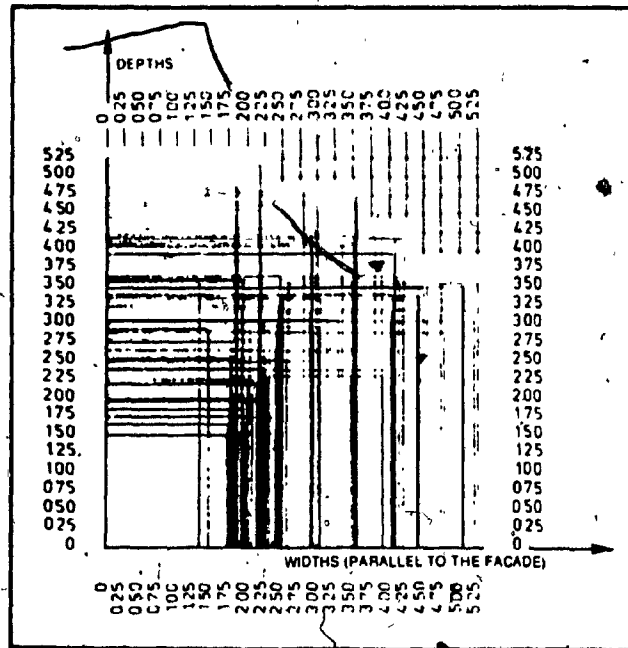

Frequency with which certain room sizes are found to occur in practice.

Fig. 2.1 Frequency of Room Dimensions Found in Practice

The preferred widths are approximately: 1.75, 2.20, 2.40, 3.00, 3.50 and 4.05 m. If the 2.20 m value is excluded, one can observe that these values are close to the multiples of 60 cm, or 6M (where M = 10 cm).

This analysis encourages the adoption of a 6M grid. The following table shows room dimensions obtained, using walls 20 cm thick, lying on the grid lines (see

figure below) and the comparison between these dimensions and the values obtained from the graph:

6M = 1mM = 1 multi-module

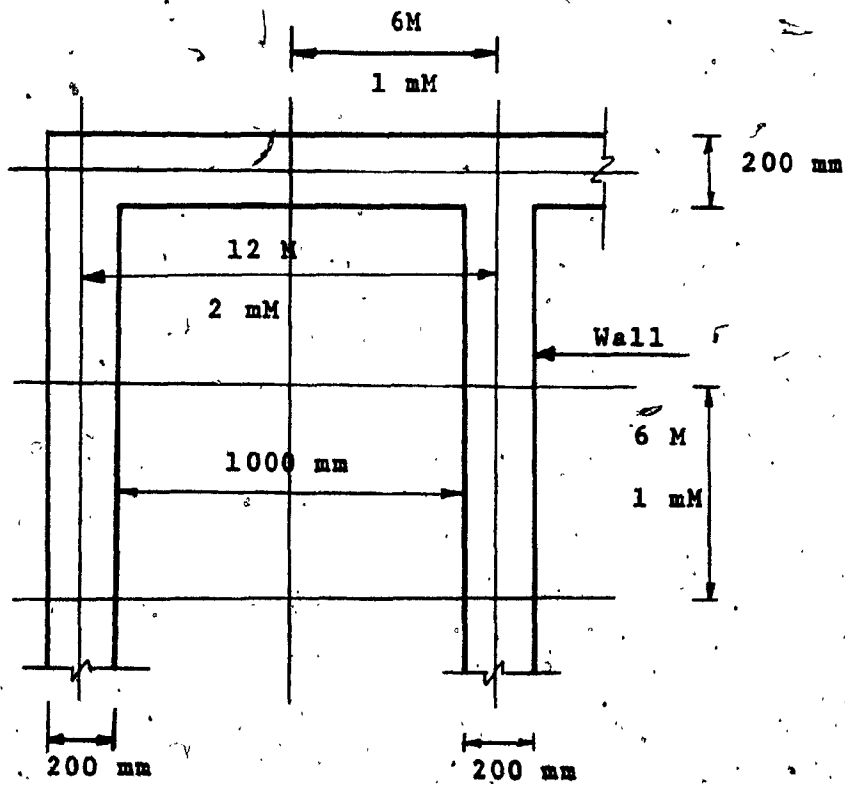

Fig. 2.2 - Location of Walls on The Grid

1 Results of the Survey	2 Series Generated from a 6M Grid	3 Room Dimension Wall = 20 cm	4 Difference D = ① - ② (cm)
1.75	1.80	3mM	15
2.20	2.40	4mM	0
2.40	2.40	4mM	20
3.00	3.00	5mM	20
3.50	3.60	6mM	10
4.05	4.20	7mM	5

Table 2.1 - Relation of Room Dimensions Provided by the 6M Grid With Those Found in Practice.

The table shows that the difference of values does not increase or decrease constantly.

It seems clear that a 6M multi-module provides a good fit to the figures found in the survey. However, these figures refer to large rooms, like living rooms, dining rooms and bedrooms. It is also necessary to analyze how well dimensions generated by the module chosen can satisfy the dimensional needs of bathrooms, corridors and kitchens.

For corridors, the minimum acceptable width is 1.00 m, and this is exactly the value which is obtained with the 6M grid: $2 \times 6M = 1.20 \text{ m} - 0.20 \text{ m Wall} = 1.00 \text{ m}$.

For bathrooms, again the minimum width is 1.00 m and the minimum depth depends on the equipment installed. It is interesting to place all the plumbing equipment in one wall.

of the bathroom, so that a plumbing tree can be pre-designed.

The minimum equipment should be: lavatory, toilet bowl and

shower. The construction code ⁽²⁰⁾ requires the minimum

dimensions according to the following drawing:

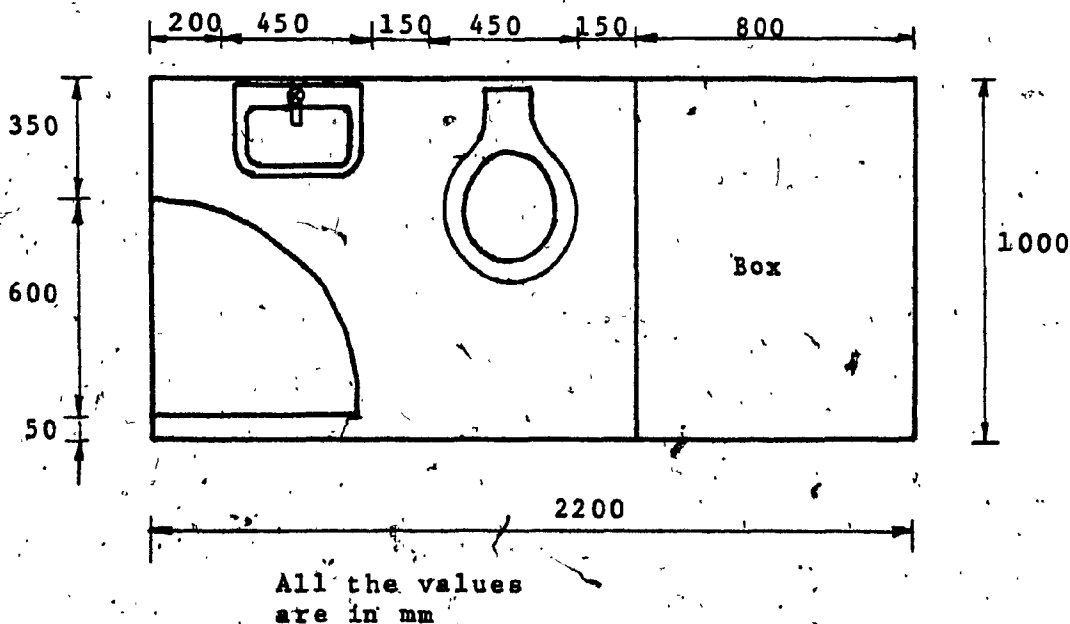

Fig. 2.3 - Minimum Dimensions for Bathrooms

According to the figure, the minimum dimensions required correspond to 2 x 6M for the width and 4 x 6M for the length.

It could be argued that, in this case, the self-helper is practically forced to adopt such measures. Indeed, if he

wanted a wider or longer bathroom, the dimensions would pass respectively from 1.00 m to 1.60 m, and from 2.20 m to 2.80 m, which are extremely large for low-cost housing.

However, since the bathroom presents the highest cost per square meter in the house, it seems reasonable to build it within the minimum possible dimensions.

The kitchen is another room which deserves a more careful analysis. The concept of a standard plumbing tree requires the kitchen to share one wall with the bathroom. However, this does not limit its size to a minimum of 2.20 m for that wall. Indeed, the kitchen could be 3 x 6M or 4 x 6M or more. This decision has to be made by the user. However, it seems that the regular grid provides enough flexibility to the user.

The municipal code also imposes some restrictions on the minimum dimensions of the kitchen. However, these restrictions do not apply to low-cost housing. There are special rules for such projects. Minimum width is 1.50 m and minimum area of 3.0 m².

The author's experience show that users tend to design large kitchens rather than small ones, due to the social

role of this room: it serves as an informal living room for the family. This is probably due to the rural background, common in low incomes.

In conclusion to this analysis, it can be said that the multi-module adopted satisfied general users' requirements with respect to room dimensions.

2.7 CORRECT MAN-EQUIPMENT INTERACTION

The necessity of studying the man-equipment interaction in the construction process was stressed at the beginning of this chapter. Indeed, this interaction is one of the most important factors during the development of a technology and should be studied in depth. The advantages of this approach were expressed by Jones. (21)

"The cost and time needed for man-machine systems designing, as a prelude to design procedures of the existing kind, is likely to pay for itself in reducing the high costs and long delays that are commonly encountered when systems are developed from an exclusively mechanical point of view."

2.7.1 The State of the Art

Some authors, among them Singleton, (22) have given a general structure for a man-machine system design. However,

they agree that this kind of approach has not yet received the attention it deserves. They also stress that these general theories are not sufficient to solve problems in specific areas. Therefore, the intention here is to try to establish some rules for a man-equipment design approach for housing construction technology.

2.7.2 Man and Machine Attributes

It is necessary, first of all, to discover which are the man and machine attributes, which will be called their inherent characteristics. Jones presents a list reproduced below. It is reproduced from Singleton. (21)

	Machine	Man
Speed	Much superior.	Lag 1 second.
Power	Consistent at any level. Large, constant standard forces.	2.0hp for about 10 seconds 0.5hp for a few minutes 0.2hp for continuous work over a day.
Consistency	Ideal for: routine; repetition; precision.	Not reliable; should be monitored by machine.
Complex activities	Multi-channel.	Single-channel.
Memory	Best for literal reproduction and short term storage.	Large store, multiple access. Better for principles and strategies.
Reasoning	Good deductive.	Good inductive.
Computation	Fast, accurate. Poor at error correction.	Slow, subject to error. Good at error correction.
Input sensitivity	Some outside human senses, e.g. radioactivity. Can be designed to be insensitive to extraneous stimuli.	Wide energy range (10^{11}) and variety of stimuli dealt with by one unit; e.g. eye deals with relative location, movement and colour. Good at pattern detection. Can detect signals in high noise levels. Affected by heat, cold, noise and vibration (exceeding known limits).
Overload reliability	Sudden breakdown.	'Graceful degradation'.
Intelligence	None.	Can deal with unpredicted and unpredictable; can anticipate.
Manipulative abilities	Specific.	Great versatility.

This is a list of general characteristics and it does not focus on any specific field. Later, a list including the characteristics needed in the construction field will be presented.

2.7.3 General Procedure to Develop Man-Machine Systems

Two systems design approaches were found in the literature. The first one was proposed by Singleton. (36)

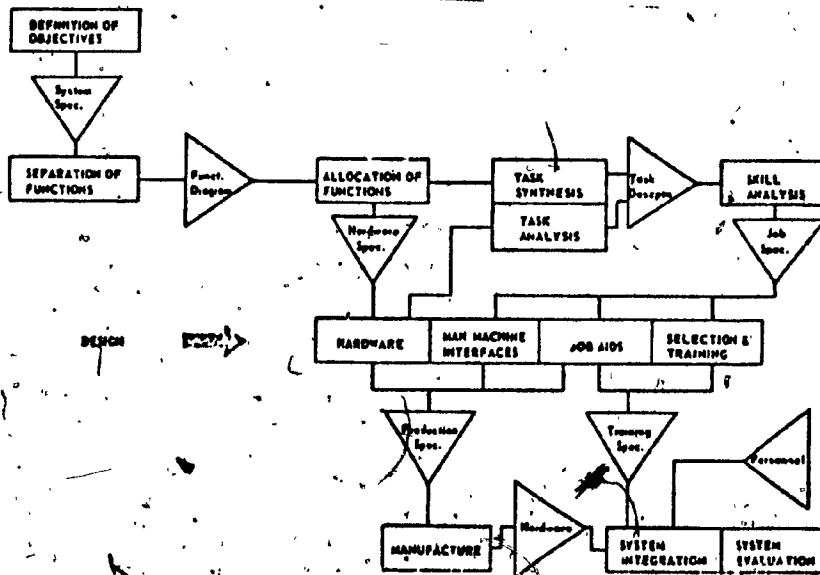

Fig. 2.4 - Procedure to Design a Man-Machine System, According to Singleton

The other approach was present in "Design Methods - Seeds of Human Futures": (21)

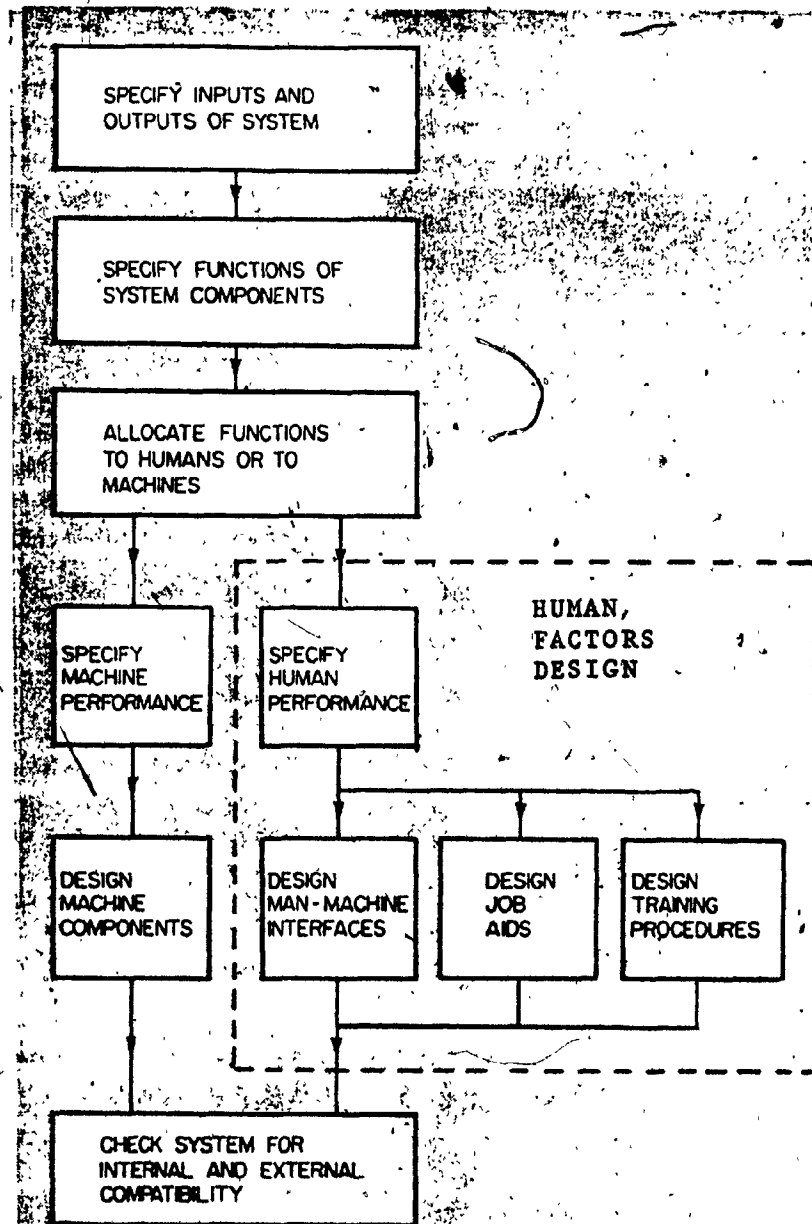

Fig. 2.5 - Procedure to Design a Man-Machine System, According to Jones

Both approaches stress the need for designing the man-machine interface at the same stage than the hardware (or machine component design). The next figure shows the difference between traditional sequence and man-machine systems design sequence. (21)

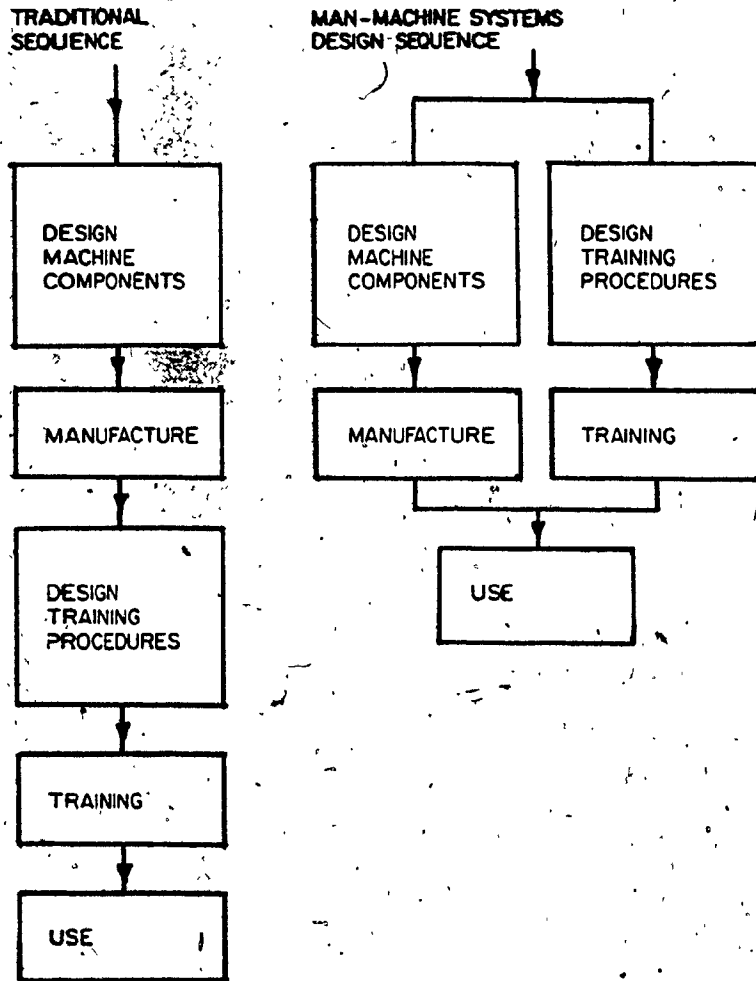

Fig. 2.6 - Difference Between Man-Machine Design Approach and Traditional Approach

2.7.4

The Housing Construction Problem

Two points are important in the study of the combined man-equipment. First, the greater or smaller participation of man and equipment in the process depends on the context where the technology is to be applied. Secondly, they have to execute tasks that utilize their potential in each of

the aspects involved, in such a way that the final result is an optimized man-equipment interaction. These considerations lead to the concept of Appropriate Effort:

HUMAN PRODUCTIVITY INCREASES IN DIRECT RELATION TO THE SUITABILITY OF TASKS TO THE INHERENT CHARACTERISTICS OF MAN. THE SAME RELATION IS VALID FOR THE EQUIPMENT.

By definition, such characteristics are not skills, since those have to be learned, requiring time and resources.

The incorrect allocation of tasks leads to a sub-optimization of man-equipment systems potential. In other words, if man and equipment are required to execute only the tasks for which they have an inherent capability to perform, the effort to fit into the system would be much less. A high productivity level would be reached faster with less skilled labour, and a more appropriate contribution by the equipment

2.7.4.1 Human Characteristics

An analysis of Table 2 shows that man's potential lies in the following characteristics: memory, reasoning, input sensitivity, overload reliability, intelligence and manipulative abilities. Such characteristics will be considered the human inherent characteristics. Another characteristic, mobility, must be added to this set, since

it enables man to move around in the construction process. Computation should also be included, since computers are not presently available to the construction process.

The inherent characteristics will also be called Primary Characteristics, which can be combined in various ways to form the Secondary Characteristics. These, also combined, will generate the Tertiary Characteristics, which express the human potential in the construction process. These three levels are shown in the following figure (next page):

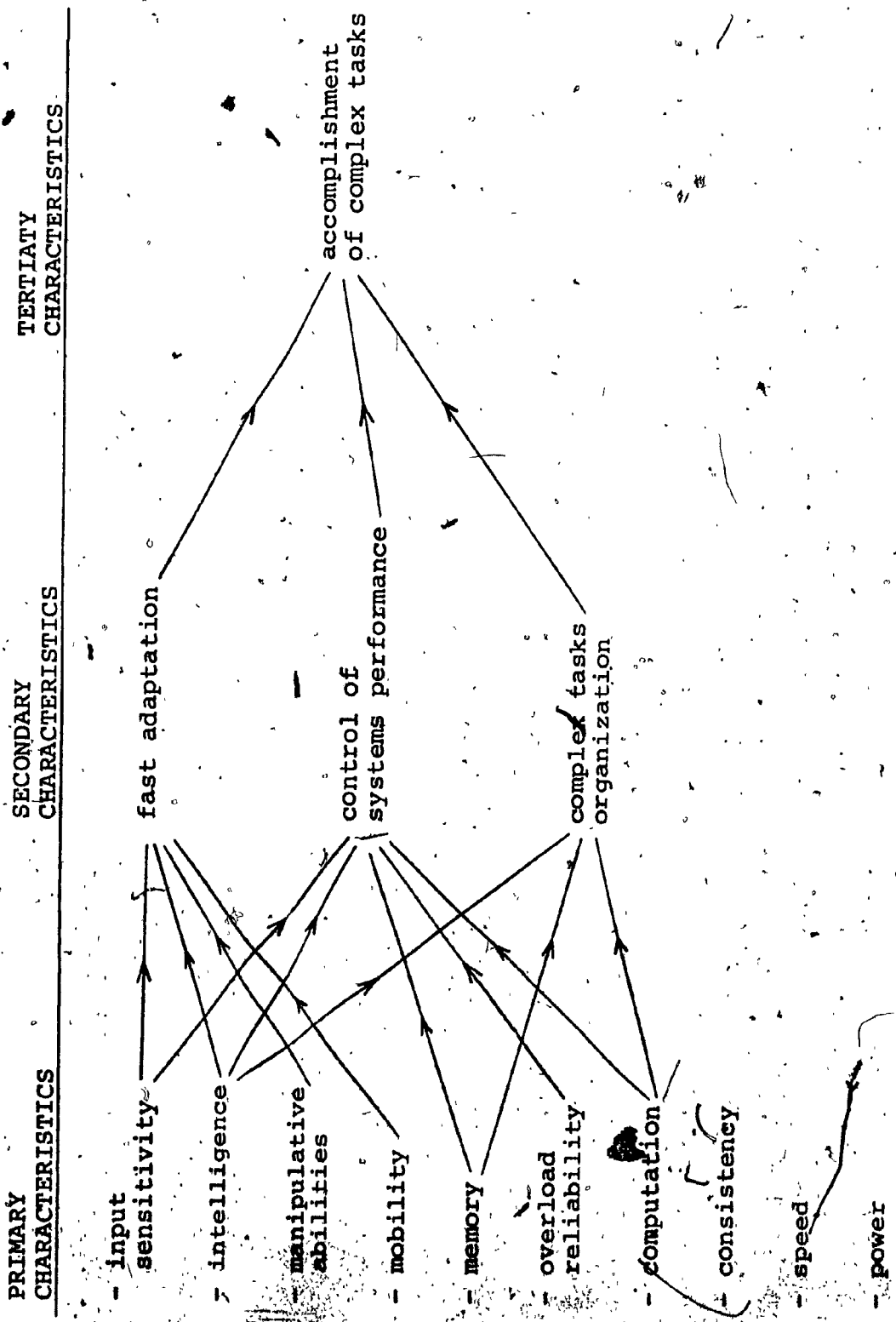

Fig. 2.7 - Human Characteristics

It is interesting to note that man is assigned for organization and control efforts, but not for the production process itself.

It should also be remembered that there are some human characteristics that are not exactly inherent to man, but, due to cultural imposition, every man has developed them to a point that they could be considered as inherent to man. One of these characteristics is the ability of man to codify and decodify different communications systems. These special learned characteristics will be noted in this study.

2.7.4.1.1 The Learning Process: The Difference Between Knowledge and Skill

Before man can perform any task, there is a learning process, where knowledge is obtained. However, knowledge and skill are different concepts. Knowledge is basically information which must be used during the construction process, and which can be obtained through a codified information source. In other words, to absorb and use this knowledge is basically a brain activity. On the other hand, skill is a brain-body activity, which has to be trained, therefore requiring a greater effort to be obtained. However, it is not possible to completely avoid any kind of requirement for skill in the whole construction process. The question is how to use those skills which require the least effort to be learned.

Departing from the ideal zone to less developed contexts, it seems reasonable to propose, at first, the replacement of machine power by human power. This option is based on the fact that machine power normally requires heavy and expensive equipment, with a high technological level and expensive operation and maintenance costs. Furthermore, the energy source, whether electrical or liquid fuel, is not always available in a dependable way. The tendency in cases where machine power is adopted, is to create the self-sufficient "islands" mentioned by Turner.

At a certain point, the decrease of productivity caused by the substitution of equipment by man will be compensated by the fact that a supporting technological "island" is not needed anymore.

The second step would be the substitution of machine speed by human speed. This change is represented mainly by electrical hand tools.

It is important to note the difference between such tools and the heavy equipment of a fully mechanized construction process.

Precision should not be provided by man in any event. This is because both manufacturing and location precision,

when provided by man, require some kind of skill which, as seen before, should be avoided.

If, with time, the context becomes able to support higher-level technologies, equipment will supply speed, and eventually power.

An interesting situation occurs when computers are considered. In this case, equipment gains some primary characteristics that were exclusive to man. These characteristics are: large input sensitivity, memory and computation. If somebody analyzes the table of man's characteristics, he can note that these characteristics, together with intelligence and overload reliability, are the ones which are necessary to provide control to the system. The evident conclusion is that now equipment is also able to exercise some kind of control, which does not require intelligence (or logical capacity, meaning potential to cope with the unexpected) or overload reliability (the last level of responsibility has to remain with man).

Another consequence of the increased potential of equipment is its new ability to organize simple tasks (single steps) or cooperate in the organization of larger tasks, due to its computing speed and memory.

However, this is not a complete analysis of the phenomenon; it is not only necessary to know if a certain technology is available and economically viable in a certain context - it is also necessary to know if the prospective user of such technology has the economical conditions to utilize such technology. This is especially important for low-cost technologies. Such problems can be solved or minimized if the government subsidizes the cost of equipment or if cooperatives are formed to buy it.

2.7.7 The Question of Precision

This basic characteristic deserves further analysis, since it has to be provided by the equipment instead of by man.

Precision in location can be provided by the equipment even if man brings the materials to their final position.

The equipment provides the location through its opposition to the material movements towards wrong directions. Any point of the equipment which opposes the material's movements can be defined as a "physical location point". In contrast to that, there is the "imaginary location point", which is visualized by man while locating the material, but cannot influence the positioning of the materials. In this second case, precision is really provided by man, who has to

locate the materials and check their position in successive attempts. The positioning and control activities can be exercised simultaneously, but this can be done only by a skilled worker.

Analysis of an example will clarify these theoretical arguments. The example is the construction of a wall using conventional technology.

In conventional technology, man builds a house, generally using bricks and concrete blocks. In this case, the process requires man to provide precision directly (naked hands), or indirectly (with tools like level, plumb line, etc.). This precision is expressed by the orthogonality and verticality of lines and the flatness of surfaces, the dimension and position of the wall. The tools do not provide precision by themselves, but help man provide some imaginary points (eg.: the alignment obtained with a string. They also help man during the control, checking to see if his work is acceptable against established standards. This second kind of tool is used in an iterative process of control: e.g., the plumb line, the square, the level, the tape.

Since man is required to perform tasks for which he does not have an important inherent aptitude, the result will be an increase in costs, caused by the fact that man

has to be trained to obtain skill. This training takes years of apprenticeship, and even if he acquires the skills, his productivity is still limited within a narrow range:

It is also important to notice that man's manipulative abilities and, more specifically, his ability to bring a certain object to a predetermined point in space decreases with the weight and size of such object. This aspect must be taken into consideration when the equipment and prefabricated elements are being designed.

2.7.7.1 Adaptation to the Material's Characteristics

The full evaluation of the question of precision can be carried out only after the analysis of the material's characteristics is considered. The reason is that precision will ultimately be located in the construction materials. In other words, the materials have to "absorb" the precision, which is being provided by the equipment. For this to happen, it is necessary to study the materials' behaviour while they are being located.

Materials can be classified into the following three types:

rigid;
flexible;
amorphous.

Probably there are some materials which cannot be precisely defined in one of these types; however, for the majority of construction materials, such classification can be easily applied.

The study of precision in materials starts with some principles about precision in construction. Some of these principles are already well-known:

1. About straight lines in space:

- to define a segment of a straight line in space, it is necessary to have at least both extreme points of this segment or one of these points and a vector.

2. About the location of rigid elements in space:

- for a rigid undimensional element in space to be located, two of its points, or a point and a vector, must be correctly located.

- two and three-dimensional rigid elements follow the same principle, but now the correct location of at least three of its points are necessary to ensure the correct location of every other point of the element.

3. About the location of flexible elements in space:

- the edges and the forces that act along the flexible element have to be defined to have it located in space.

4. About the location of amorphous elements:

- each point of the surface of an amorphous element must be obtained individually.
- the exception to this principle is the case of the horizontal surface on the top of a material plastic enough to have a fluid behaviour.

5. About the transmission of precision through rigid elements already located:

- a rigid element can have one or more points used for the location of another element.

a three-dimensional rigid element has automatically defined the planes parallel to its surfaces.

With these principles in mind, it will be possible to develop a method to transmit precision throughout the construction process, in such a way that not only the equipment, but also the already located elements will participate of such transmission.

Some examples show that the transmission of precision can be made through already located elements. This is the case of the interlocking sulphur blocks, developed at McGill University. (25)

2.7.8. The Question of Control

Control is directly dependent on knowledge: without a known reference pattern, it is not possible to verify if the real product or process is correct or not. This verification is the system control.

However, in some cases, such explicit control can be replaced by a control implicit to the system. (Such control has the advantages of not requiring a pre-learned reference pattern, and avoiding waste of time and material due to wrong procedures.

The basic idea is to design the equipment in such a way that only one sequence of procedures, as well as one way of executing a certain activity, is possible. In other words, it could be called a system with "logical rigidity". Such concept will be explored during the development of the equipment.

2.7.9. Building Sub-Systems Without Clearly Defined Basic Characteristics

The construction process also includes some activities where the division between knowledge and skill is not clearly defined, and where precision is not an explicit component. Among these activities are three which deserve special analysis: to execute the plumbing and electrical systems, and to construct the roof.

These activities involve some kind of brain activity that could be called an "intellectual ability" to solve the many problem situations that emerge, using only some basic principles and routine procedures. In terms of the five basic characteristics, it seems that there is a kind of pulverization of organization and control, in such a way that there are many small decisions to be made in each situation. The problem is that these decisions require special knowledge of some principles. It seems that the difficulty remains in using those principles in specific situations, with great differences from each other.

In other words, the worker finds great trouble to surpass the large gap between the basic principles he is using and the reality in which he is working. The difficulty does not reside in executing the task itself, but in taking the decisions on how to apply the principles. To minimize the problem, it is necessary to minimize the gap. So, if decisions are made in advance, minimizing the variety of solutions, the knowledge to be learned is restricted to the pre-designed solutions. As an example, a standard plumbing panel should be adopted instead of an ever different plumbing installation. The panel would be drawn full scale on a plywood sheet and copied by each self-helper.

2.7.10 Distribution of Tasks - The Real Situation

The distribution of tasks between man and equipment, with each of them providing some of the five basic characteristics, does not present so clear-cut a pattern as was suggested by the graph presented earlier. One of the reasons for the presence of "grey" areas was already referred to: the final decision depends on the financial condition of the owner.

Other problems related to that initial distribution refer to the available technology. For instance, in a certain moment, it is advantageous to have a machine providing speed for a certain task, but if there is no such machine available, the initial choice cannot be kept, and man has to provide the speed.

In general terms, it could be said that the graph gives an initial solution, which is further influenced by other specific factors.

2.7.10.1 The Case of Porto Alegre, Brazil

Porto Alegre is located in a developing region, so the first approximation would suggest that man would be in charge of providing organization, control and power, while the speed has gradually to change its source from man to equipment, which also has to provide precision.

This initial evaluation will be influenced by the specific context. The site where the work will be carried out is a squatter settlement, which is located on the slope of a hill without paved streets.

The electrical power is provided only by one phase plus neutral line, impeding the use of powerful electrical machines. Only hand tools can be used. There is no

evaluation of the financial capacity of the dwellers, but a survey carried out by the author among the potential self-helpers showed that their monthly contribution would stay between Cr\$1,000.00 and Cr\$2,000.00 (C\$15.00 and C\$30.00).

A research in the local market showed that a concrete mixer would cost about Cr\$50,000.00 plus a fuel-powered motor (Cr\$20,000.00), operation and maintenance costs. So, the initial cost would be around Cr\$70,000.00 (C\$1,100.00), while the operation and maintenance costs would vary according to the use, but would not be less than Cr\$10,000.00 (C\$150.00) per user. A sawmill would cost initially about Cr\$150,000.00 (C\$2,500.00) and would have a maintenance and operation cost of Cr\$1,000.00 (C\$15.00) per dweller. These values give an idea of the impossibility of using such equipment. Indeed, due to the scarcity of financial resources, it seems clear that all the available capital should be used to buy materials, while power and the greater part of speed would be provided by man.

The proposal for a labour intensive construction process seems reasonable in the context presented above. Indeed, the more man uses his own effort to provide the elements necessary in the construction process, the more he can devote his scarce resources to materials for his house and other primary needs. Furthermore, the purchase of expensive

equipment would only be affordable if the settlement were well organized to minimize the costs for each dweller; this is not the present case.

In conclusion, it can be said that, in the distribution of tasks, man will play the main role. He will provide organization, control, power and most of the speed. Equipment will provide some speed, mainly through electrical hand tools, and precision.

CHAPTER III

PROPOSED CONSTRUCTION SYSTEM

CHAPTER III

PROPOSED CONSTRUCTION SYSTEM

A construction system based on the characteristics discussed in Chapter II is proposed here.

The author's experience in conducting a field test of building a prototype utilizing this system is also discussed. A grant was obtained from a government agency to pay some of the costs.

The application was carried out in a squatter settlement (or "favela"), called "Beco Do Adelar", located on the border of the urban area of Porto Alegre. Such application can be divided into two basic phases: selection of families and construction of prototypes.

3.1 Selection of Families

At first, a contact with the leader of the favela was established, and the idea of conducting an experiment in housing using self-help labour was explained to him.

The leader reacted favourably to the idea and offered his cooperation. After that, a meeting with the favela's

union directorate was held, and the same idea was explained to them in this meeting. It was established that a new meeting with all the families of the favela interested in the experience would be held.

About 30 families attended this new meeting, when a general explanation about the experiment was given. The explanation included:

- basic information about the construction system;
- the material acquisition procedure; and
- the criteria to select families.

The information about the construction system included a short talk about the design phase and the various sub-systems of the construction phase. Emphasis was placed on the foundation, walls and roof systems.

Material acquisition was divided between the owner and the author. The criterion for this division was: since it was an experiment, it could result in failure, and it would not be fair to ask the owner to pay for the materials of an experiment, for which he was not responsible. However, if he could reuse the materials in another house, or sell them, he would have to pay for them. In other words, the materials that could not be reused would be paid for by the

author using the grant obtained, and the materials which could be used later would be paid for by the owner. The equipment would also be paid for by the author.

The criteria to select the families were;

- to have a great desire to build the house;
- to have a site which would allow the application of the construction system. The site should be large enough (more than 100 m²), and without huge rocks;
- to agree to helping other people, if they wanted to build their houses by the same method;
- to have economic conditions adequate to pay for the reusable materials.

From the meeting, 6 families were pre-selected. From those, more specific information was gathered, and finally, two families were selected. However, one of them had to abandon the program after the design phase. The problem was that they expected to obtain a site where they could build their house, since their actual site had too many rocks. However, due to bureaucratic problems, they could not obtain the site in time and dropped from the program.

The other family continued through the construction phase.

3.2 USE OF MODULAR COORDINATION

The construction system includes three sizes of foundation and wall segments: 6M, 12M and 18M. The reasons for the adoption of such sizes are: ergonomic considerations with respect to equipment size and weight (which will be discussed later) and an analysis to determine the minimum equipment diversity necessary to satisfy the user's needs.

In this analysis, the potential of a selected set of multiples of the multi-module adopted is measured through the critical number⁽¹⁾ obtained with such a set. An initial set of 12M and 18M generated the following critical number:

$$C.N. = (2mM - 1) \times (3mM - 1) = 2mM$$

$$\text{where } 1mM = 1 \text{ multi-module} = 6M$$

This means that this set can generate every multiple of the multi-module, from 2mM. To allow greater flexibility to the user, 1mM is included in this set. Various combinations of such multiples are possible to obtain larger wall sizes. They are shown in the following table:

FORM SIZE (Quantity in parenthesis)	TOTAL SIZE
(1) 1mM*	6M
(2) 1mM; (1) 2mM*	12M
(3) 1mM; (1) 1mM + (1) 2mM; (1) 3mM*	18M
(4) 1mM; (2) 1mM + (1) 2mM; (1) 1mM + (1) 3mM; (2) 2mM*	24M
(5) 1mM; (3) 1mM + (1) 2mM; (2) 1mM + (1) 3mM; (1) 1mM + (2) 2mM; (1) 2mM + (1) 3mM*	30M
ETC	

* Preferred combination in normal circumstances

Table 3.1 - Various Options to Combine the Multimodules Adopted

Some solutions are presented below in order to show the potentials of this modular design.

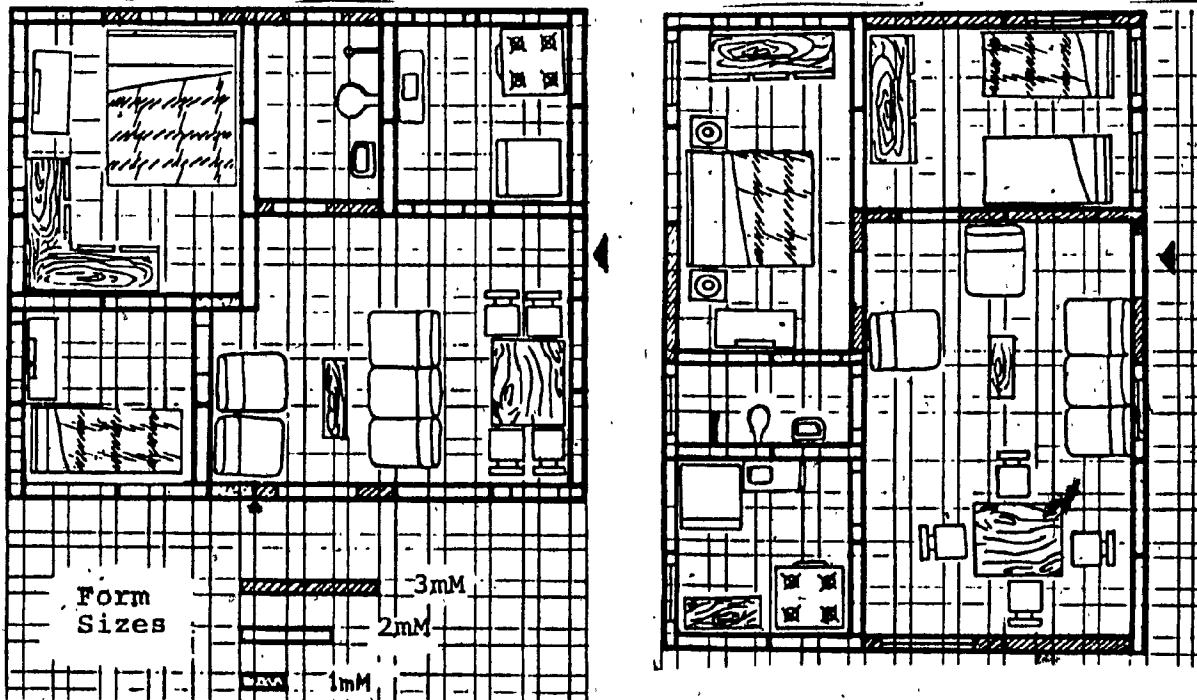

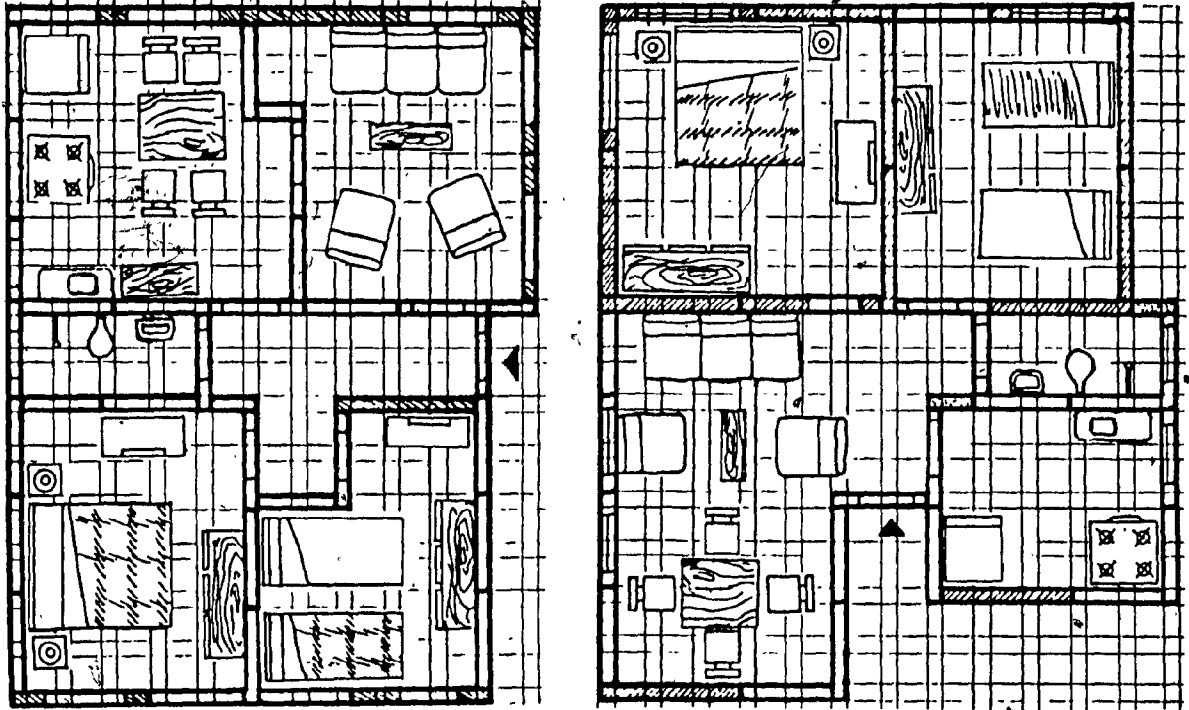

Fig. 3.1 - Various Architectural Solutions Obtained With the Use of the Multimodules Proposed

3.3 DESIGN PHASE

3.3.1 Proposed System

The participation of the self-helper in the design phase is limited to the single dwelling. This participation is manifested through the use of the modular grid proposed above. The self-helper is presented with a 1:10 wooden model, which includes:

- the standard furniture for five rooms: living room (one sofa, two armchairs, 1 small central table);
- kitchen (1 dining table, 4 chairs, 1 refrigerator,

1 stove, 1 counter, 1 sink tied to the plumbing panel); main bedroom (1 double-size bed, 2 lamp tables, 1 closet, 1 drawer); children's bedroom (3 single beds, 1 closet, 1 drawer); bathroom (lavatory, toilet bowl, shower, all tied to the plumbing panel);

- a modular grid basis 13 mM x 16 mM, where the wall panels could be fixed;

- modular panels having the 3 equipment sizes (1 mM, 2 mM and 3 mM). These panels may have a window, a door or be closed. The thickness of the panels (2 cm) corresponded in scale to the thickness of the actual walls (20 cm). On the top of the panels, a coloured line identifies its size: 1 mM has a blue line, 2 mM a red one, and 3 mM a green one. These colour identifications are important for illiterate people and will be used when they copy their final solution.

The self-helper is asked to develop his design solutions with the model, following certain procedures and respecting certain constraints. An architect advises him in any doubt he has and comments on the consequences of the solutions adopted. The self-helper can keep his solutions or change them according to his own judgment.

The constraints which are imposed on the design are:

- only modular dimensions can be adopted;
- the plumbing panel has to be shared between the bathroom and the kitchen;
- unless special conditions exist, the preferred combinations of panel sizes have to be used.

The recommended procedures are:

- to locate the rooms according to the best solar orientation, which is:

ROOM	BEST ORIENTATION AND WINDOW LOCATION
- living room	North (East and West are also good)
- bedroom	North (East and West are also good)
- bathroom	South
- kitchen	South

Table 3.2 - Room Orientations

- to dimension each room according to its furniture; the self-helpers are asked to arrange the furniture of the rooms first, and enclose this furniture with the wall panels as is shown in the following picture:

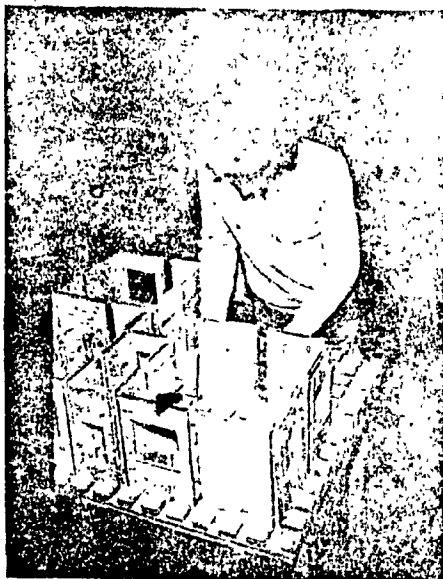

Figure 3.2 - Self-Helper Designing His House

This procedure helps him to deal with room dimensions. If he were to establish room dimensions without references, the lack of awareness due to inexperience in this kind of work would embarrass him. The probable consequence would be a badly-dimensioned house.

- to locate the doors and windows and change their position if the solution is not satisfying.

After a trial enclosure, the self-helper will locate windows and doors more carefully.

All these procedures are repeated for each room. After the whole house has been designed, the architect studies the

solution achieved and discusses it with the self-helper, who will decide about further changes.

When the final solution is achieved, the self-helper receives a sheet with the modular grid. He has to reproduce his solutions on this grid, using the colours on the top of the panels. Windows and doors are represented too, according to the code below:

Window



Door

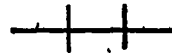

Figure 3.3 - Code Used to Represent Openings

Furniture is not copied.

Before the self-helper starts his work, the architect provides him with some information related to the cost of construction, and the size of his site and its influence on the house design.

Cost information is not specific for each item, since this would be time-consuming, while the dweller needs fast answers for his decision process. Instead, an average cost for each grid square he increases his solution is provided. With that, the self-helper has a basic idea of the total cost of the house, just by counting the number of the squares and multiplying by the unit cost. Also, if he expands a

room, he can know the increased cost by counting the number of squares added.

The size of his site also has a strong influence on his design solution. Before the design phase starts, the site is visited and measured. After, these dimensions are reproduced in the modular grid with scotch tape. According to the municipal code, windows have to be 1.50 m from the site limit. This information is transmitted to the self-helper, who can then develop his solution. Of course, he cannot keep all this data in mind. In the case of a mistake, the architect is charged with alerting him.

The design procedure described above presents some important advantages. First, the self-helper is able to express his expectation in a very easy way. The solution achieved through this procedure is much more suited to his needs than a solution provided by a huge housing project. This subject will be discussed in the next section. Secondly, he designs his house according to his economic constraints and potentials. He is able to know the cost of the house from the very beginning, and makes his decisions according to such information. Also, he makes trade-offs between the sizes of the various rooms. Thirdly, this procedure is much less time-consuming than a formal architectural approach. This subject will be commented on later. Fourthly, since the self-helper reproduces himself the

solution he adopted, this procedure will help him during the construction phase. If he were given a drawing of his solution, he probably would have much more difficulty understanding it. Fifthly, the use of modular panels familiarizes him with such methodology, making it much easier for him to work with modular equipment during the construction phase.

The full potential of having the owner as the designer of his house will be understood in the next section, when real cases will be presented.

3.3.2 Field Results

The first family, called Melo, was represented by the mother, who started to define the solution alone and, later, received the cooperation of her husband. The house of the second family, called Ramos, was designed by the father.

In both cases, the procedure was the same. The modular grid was presented and the rules to work with the model were explained. These rules were:

- to design the house using the modular grid;
- to share the plumbing panel between the bathroom and the kitchen;

- to respect the borders of the site and keep the windows 1.5 m away from them.

Other information referred to the cost of each square of the multi-modular grid added to the solution, and to the orientation of rooms with respect to the sun.

It was suggested to the self-helpers that they start their design in a corner of the base panel, so that they would use the space better. To dimension the rooms, they followed the instructions explained above.

The author noticed at the start a certain lack of self-confidence from the mother of the Melo family. But with time, she gained more confidence and was able to manipulate appropriately the model and explore its potentials. When her husband arrived, some discussion about the solution took place until a final agreement. Then the architect, Reinaldo Roesch da Silva, and the author proposed some changes. Very few were accepted. The whole process took no more than two hours. After that, the solution was copied as described earlier.

The author proposed to the Melos to try another solution and to choose the better. However, they refused, stating that that one was quite satisfying.

The solution found by the Melos is presented in the following page, and it is worthwhile discussing. It is interesting to note that the kitchen is the largest room and is the center of the house. This is possibly due to the rural background of the Melos. This background is also responsible for other rather unusual solutions adopted: the bathroom is at the corner. Indeed, the prime intention was to put it outside the house, as is normally made in the countryside.

The Melos have one daughter and four sons. It seems that the daughter deserves much more attention and vigilance, since the access to her room is through her parents' room. The boys, on the other hand, can be as free as they wish, so they have a room which not only has independent access to the kitchen and bathroom, but also they have an independent access to outside the house.

It seems clear that such a solution would never be found in any pre-designed house. This stresses the capacity of the design system to allow the self-helpers to express their needs.

The second house designer provided a different solution, which was also influenced by his urban background. Mr. Ramos understood quite easily the instructions and designed his house in 45 minutes. Again, the author's

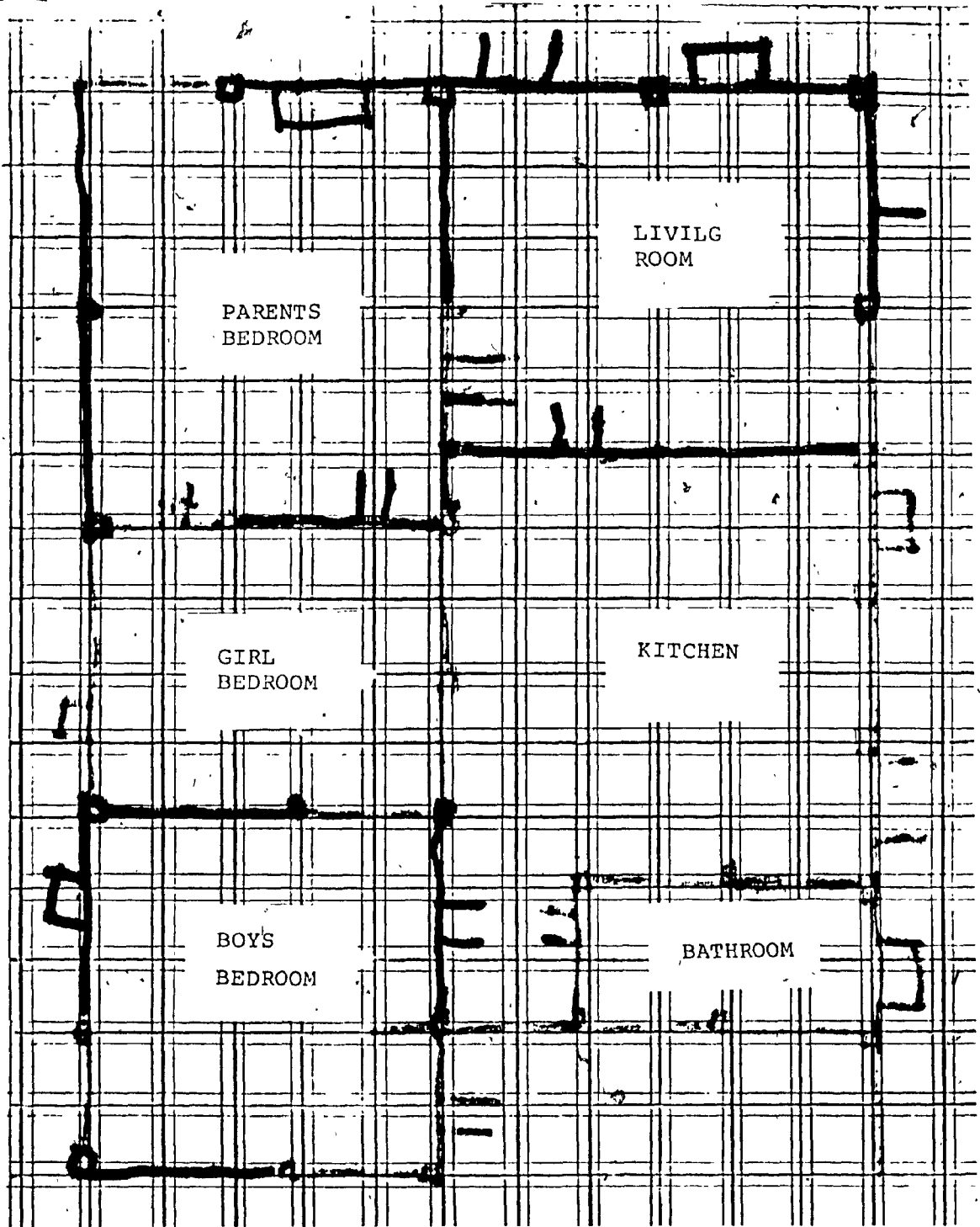

Fig. 3.4 - Drawing of the House Layout
Made by Mrs. Melo

suggestion to look for an optional solution was refused. His solution is presented in the next pages.

Some features should be noticed: the bathroom is inside the house; the living room is the center of the house; there is some preoccupation with privacy and efficiency with the adoption of a small corridor.

Again, it seems clear that the owner was able to develop a solution according to his needs, showing the potential of the method.

The following pictures show Mr. Ramos designing his house:



Fig. 3.5, 3.6 - Mr. Ramos Designing His House

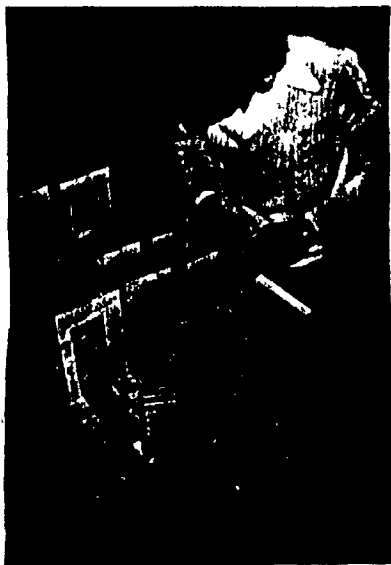

Fig. 3.7

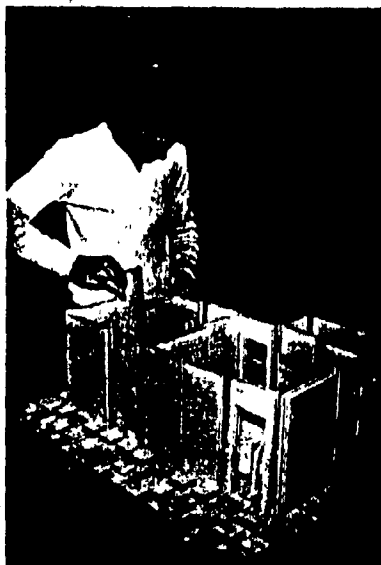

Fig. 3.8



Fig. 3.9



Fig. 3.10

Fig. 3.7, 3.8, 3.9, 3.10 - Mr. Ramos Designing His House

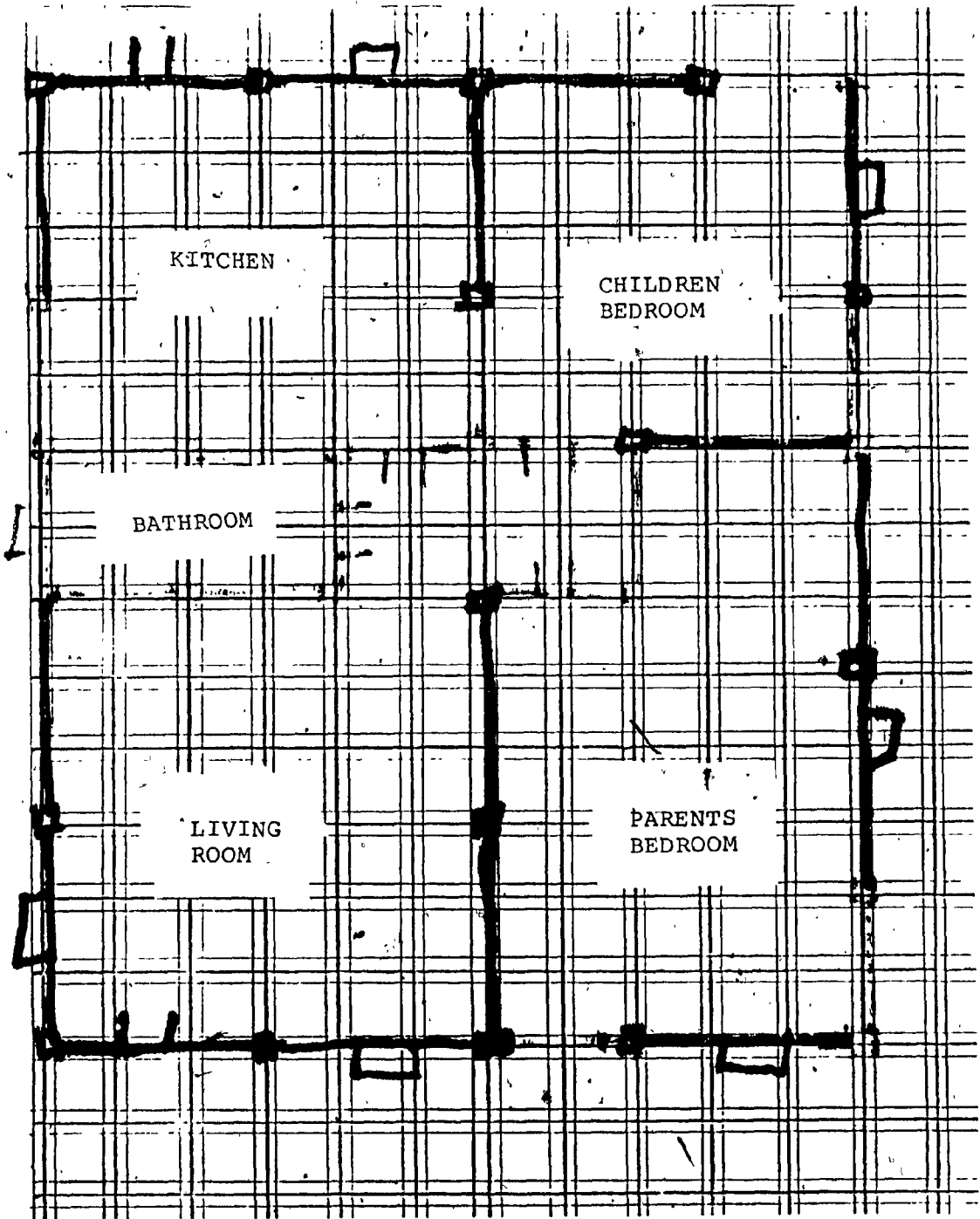

Fig. 3.11 - Drawing of the House Layout Made by Mr. Ramos

3.4 CONSTRUCTION PHASE

3.4.1 Location of the House

3.4.1.1 Proposed System

Locating the house on the site is one of the most difficult tasks in the construction process. This difficulty comes from the fact that, to locate a house in space, precision is required. Such precision is manifested in the dimensions of the various parts of the house, the horizontality of the plane where such dimensions are registered, the location of the house on the site and in the angles between the various lines.

In the traditional process of construction, such precision, as stated earlier, is provided by man through a complicated process, where the principles are applied in so many different ways that only somebody very skilled and with a certain intellectual background can be in charge of such a task.

To overcome such difficulties and allow the self-helper to locate the house by himself, a locating system, based on the adopted modular grid, is proposed. Such locating system is expected to provide the precision elements discussed earlier, plus the verticality for the walls, without needing any skill from the self-helper.

The system consists of an aluminium frame composed basically of two parts (see following figure), nodes which provide the angular precision and verticality, and circular tubes, which transmit horizontality and provide the dimensional precision. Such tubes have modular lengths. The precision transmitted by such a frame is retained in steel tubes with square cross-sections, which pass inside the nodes and are driven vertically into the ground.

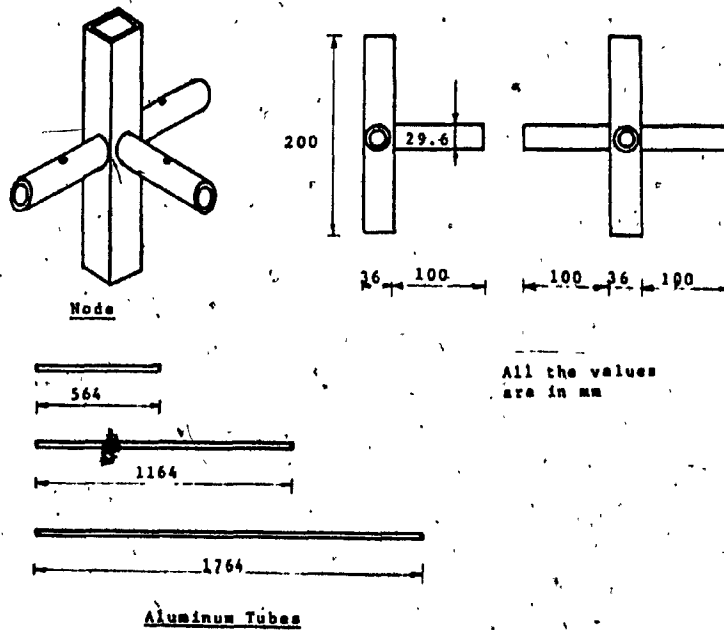

Fig. 3.12 - Elements of the Aluminium Frame

Since the elements of the system are already defined, it is necessary to describe the procedure.

The location of the house on the site starts with a copy, in full scale, of the perimeter of the solution adopted, using the aluminium tubes and nodes (see following picture).



Fig. 3.13 - Self-Helper Copying the Perimeter of the House Using the Aluminium Frame

For easier orientation of the self-helper, the tubes are marked with the same colours of the drawing made by him.

This aluminium perimeter is laid on the ground, and the user moves it until the correct position is obtained. If the ground is not flat, this can provoke some lack of

precision. However, at this stage, the location of the perimeter serves only for determining the position of the two first steel tubes.

The steel tubes driven into the ground have the function of providing the precision to the wall forms. This precision includes the levelling of the forms, its verticality and its positioning. Thus, the distance between two successive steel tubes must be equal to the size of the forms.

These first two steel tubes are fixed in the ground in the following way: a 20 x 20 x 40 cm hole is made in the ground where the tubes will be located. After, an aluminium structure keeps a modular distance between the tubes, also ensuring that they are parallel. The tubes are positioned with the help of a spirit level (see figure below).

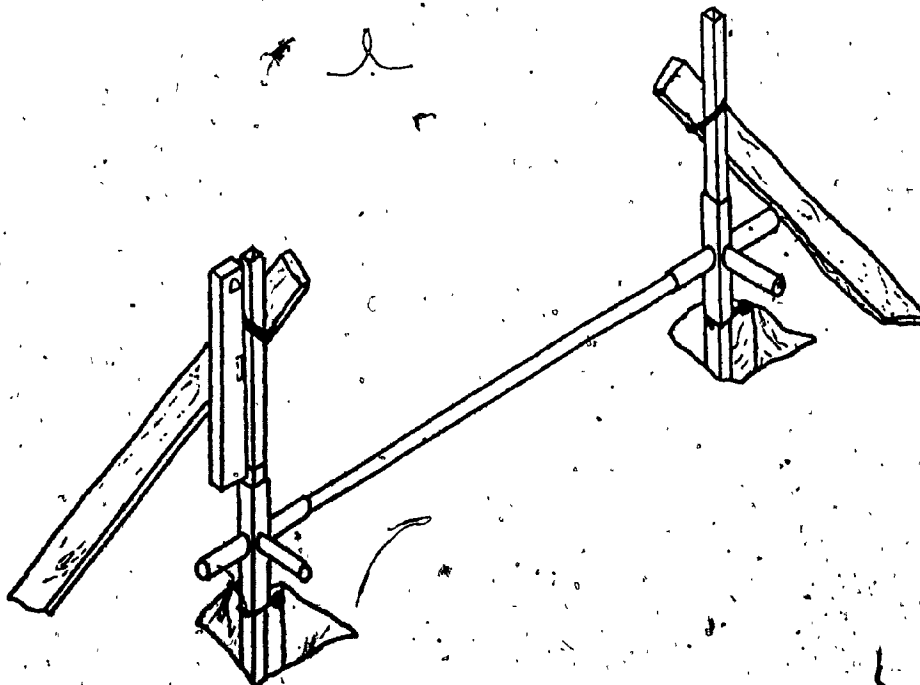

Fig. 3.14 - Location of the First Two Steel Tubes.

When the tubes are levelled, soil-cement is poured into the holes and tamped with a timber pole or a 8 cm x 8 cm wooden piece. The soil-cement takes at least 24 hours to acquire enough resistance. After this time, the location process is restarted. The procedure to locate the other steel tubes is described below:

1. Two pairs of nodes joined by aluminium tubes are placed on the steel tubes. They are prevented from sliding down by clamps fixed to the steel tubes!

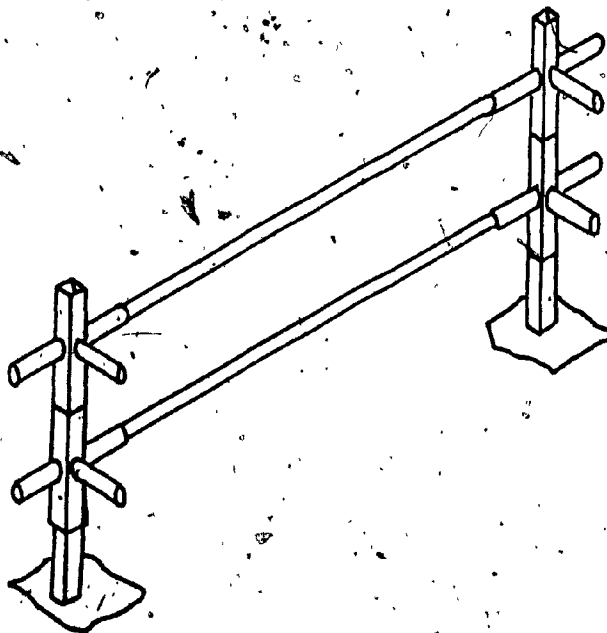

Fig. 3.15 - Aluminium Nodes Placed on the First Two Steel Tubes

- Aluminium tubes are fitted horizontally in the lower nodes, having the same modular dimension of the form. To prevent these tubes from sliding off the nodes, pins are used. The deflection due to the weight of the tubes is less than 1.0 mm for the tube 2 m long, and 5mm for the tube 3m long.

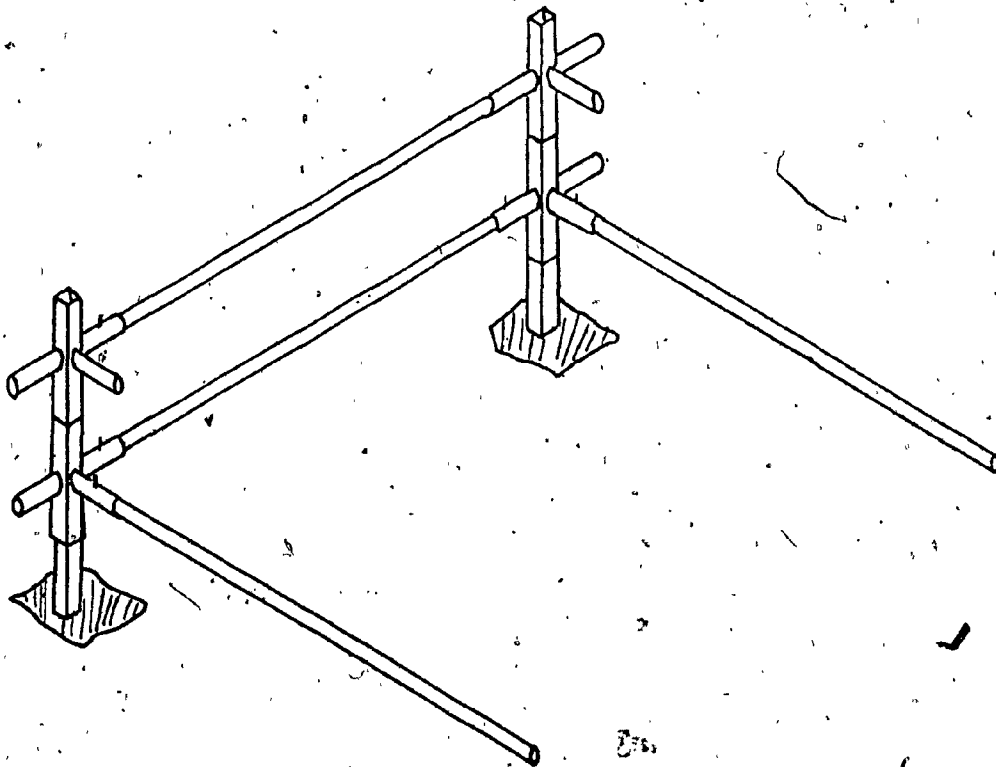
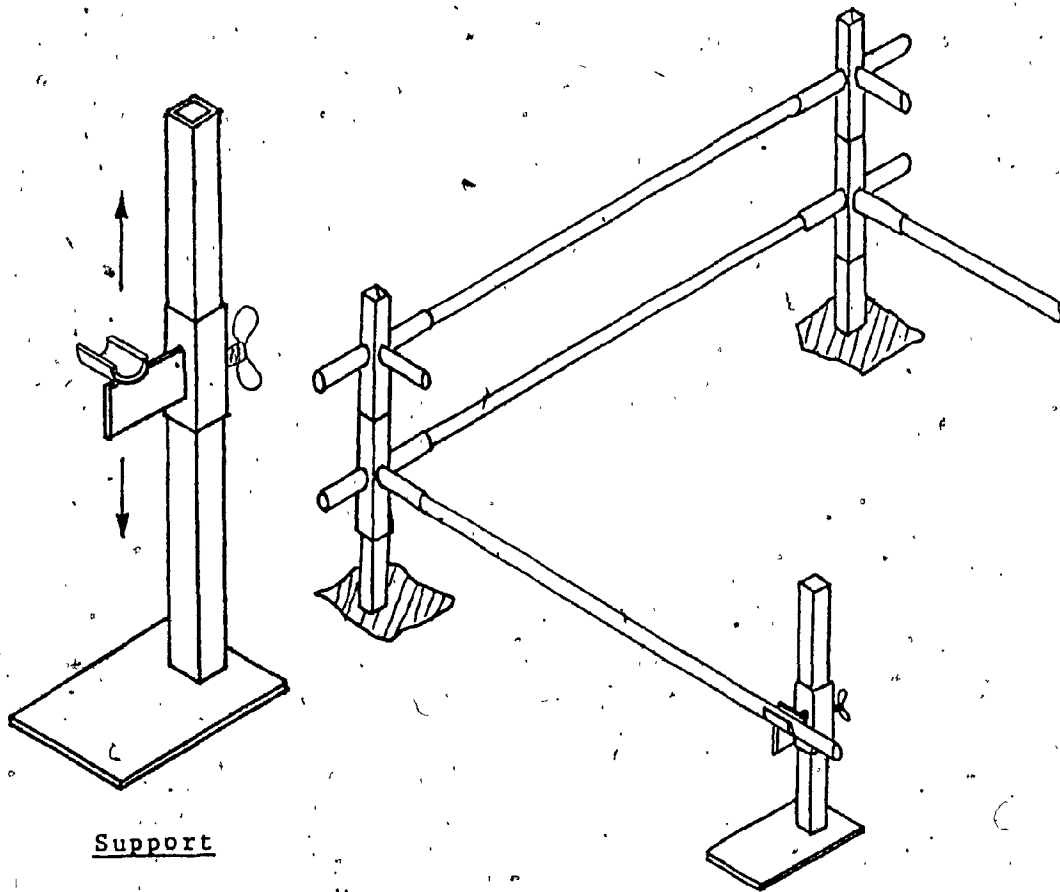

Fig. 3.16 - Aluminium Tubes Connected to the Nodes

- To avoid further deformation, when the complete frame is connected to the end of these aluminium tubes, support devices are used.



Support

Fig. 3.17 - Device Used to Support the Tube

A semi-circular support slides on a vertical tube up to the aluminium tube height, and is fixed by a butterfly bolt.

4. The lower aluminium frame is completed. Again, pins are used. The tops of the last nodes are around 4 mm lower than the previous ones due to loose fitting between the various elements plus the deflection on the aluminium tube.

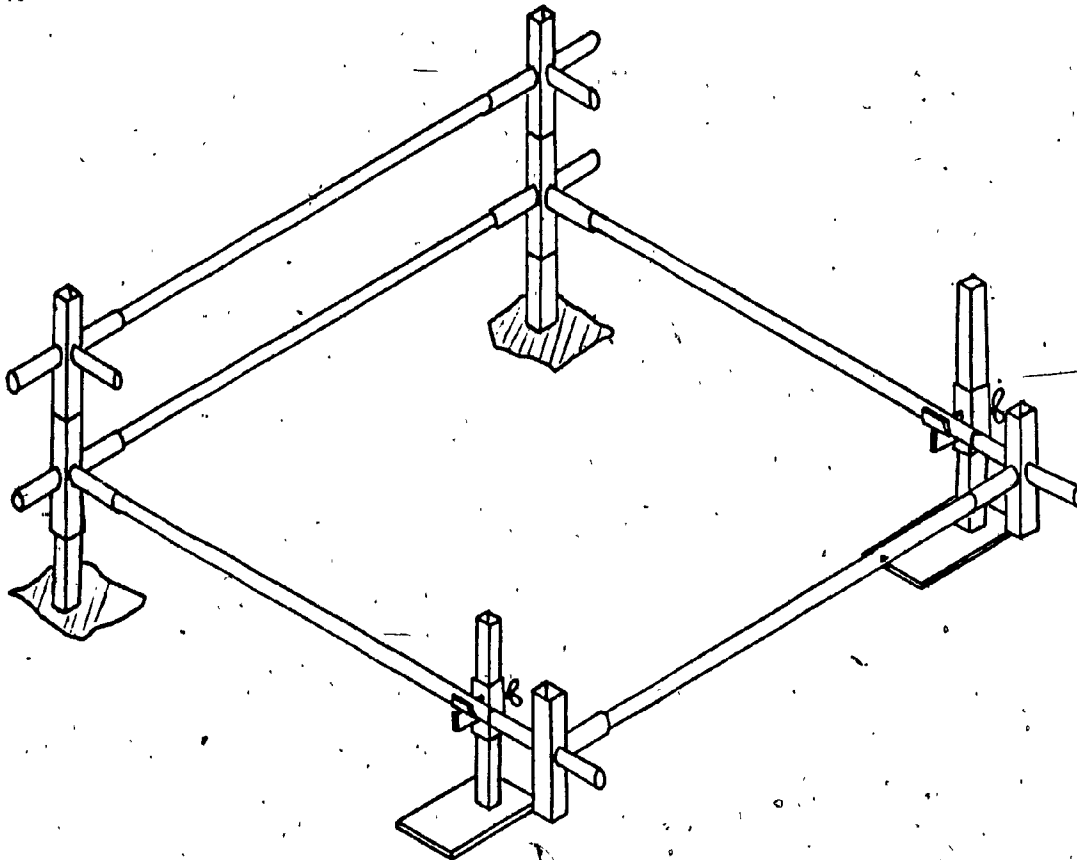

Fig. 3.18 - Completion of the Lower Aluminium Frame

5. The upper frame is positioned in the same way, also oriented by the previous steel tubes. The reason for this double aluminium frame is to prevent a large cumulative error in the location of the tubes. If only one frame were used, the cumulative effect of looseness between the previous steel tube and the node, the node and the aluminium tube and, finally, the aluminium tube and the second node would provide a displacement

of 10.0 mm on the top of the next steel tube, as shown in the figure below, if the tube height is 70.0 cm.

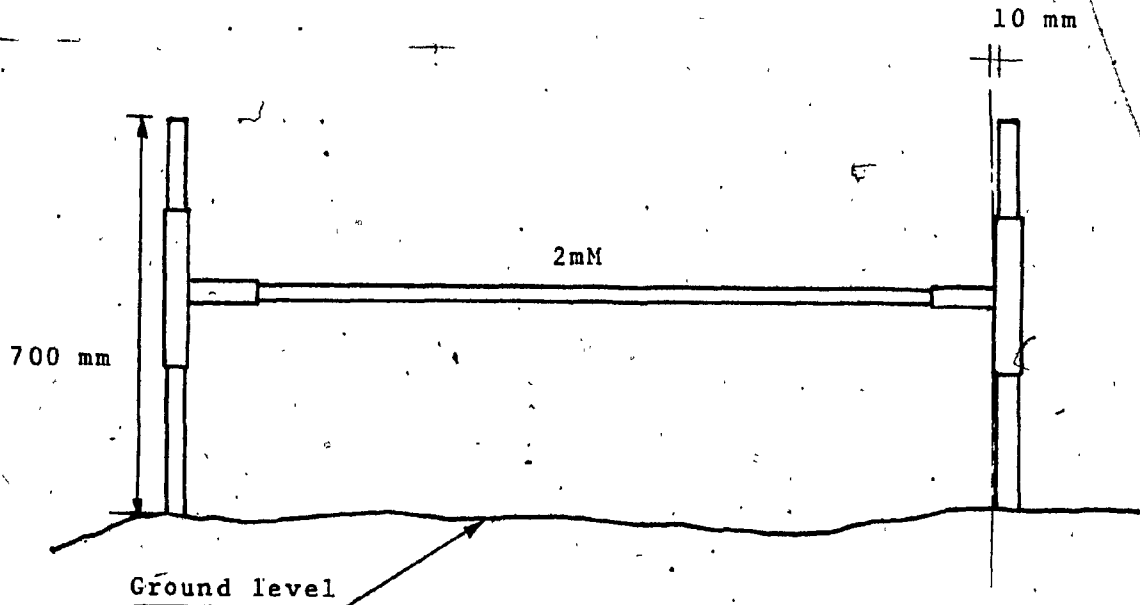

Fig. 3.19 - Displacements Produced by Loose Fittings

If this process were repeated five times in the same direction, the final displacement would be 50.0 mm. Since these steel tubes are extended up to the total height of the house, the displacement on the top of this total height between the first and the last tube would be 170.0 mm, which is unacceptable. The double frame forces the next steel tube to be parallel to the first one, since the distance between the center of the nodes of both frames is the same.

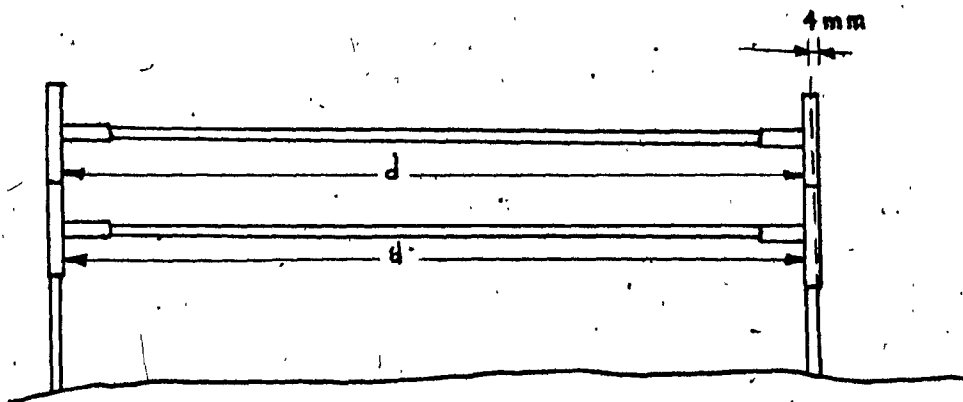

Fig. 3.20 - Displacement Produced by the Double Aluminium Frame

6. The next steel tubes are slid into the nodes and driven into the soil with a 3 kg hammer, until the top of the tube equals the top of the upper node. This is shown in the following pictures.

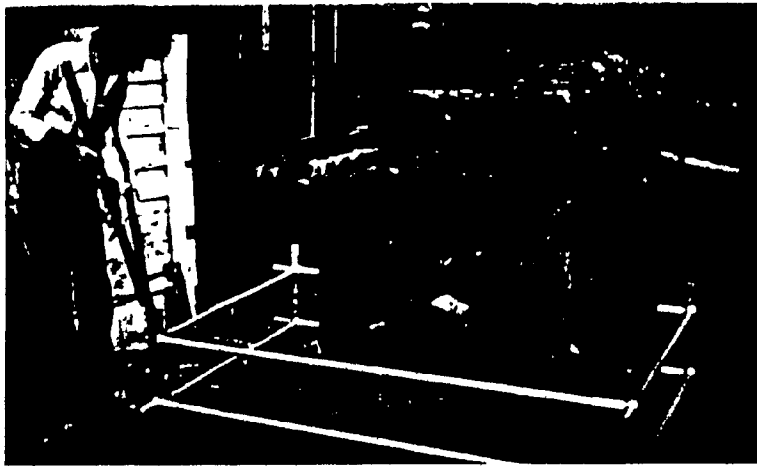

Fig. 3.21

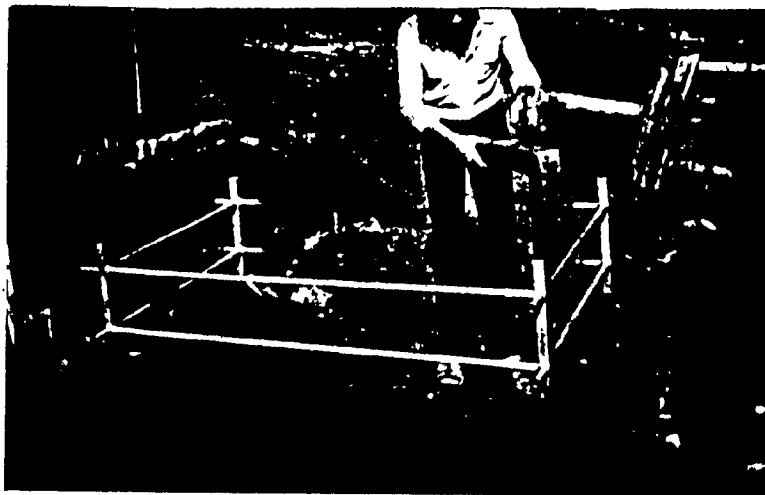

Fig. 3.22

Fig. 3.21, 3.22 - Self-Helper Driving the Steel Tubes Into the Ground

7. The clamps are removed from the previous steel tubes and fixed in the new ones, under the lower nodes.
8. Both aluminium structures are removed.

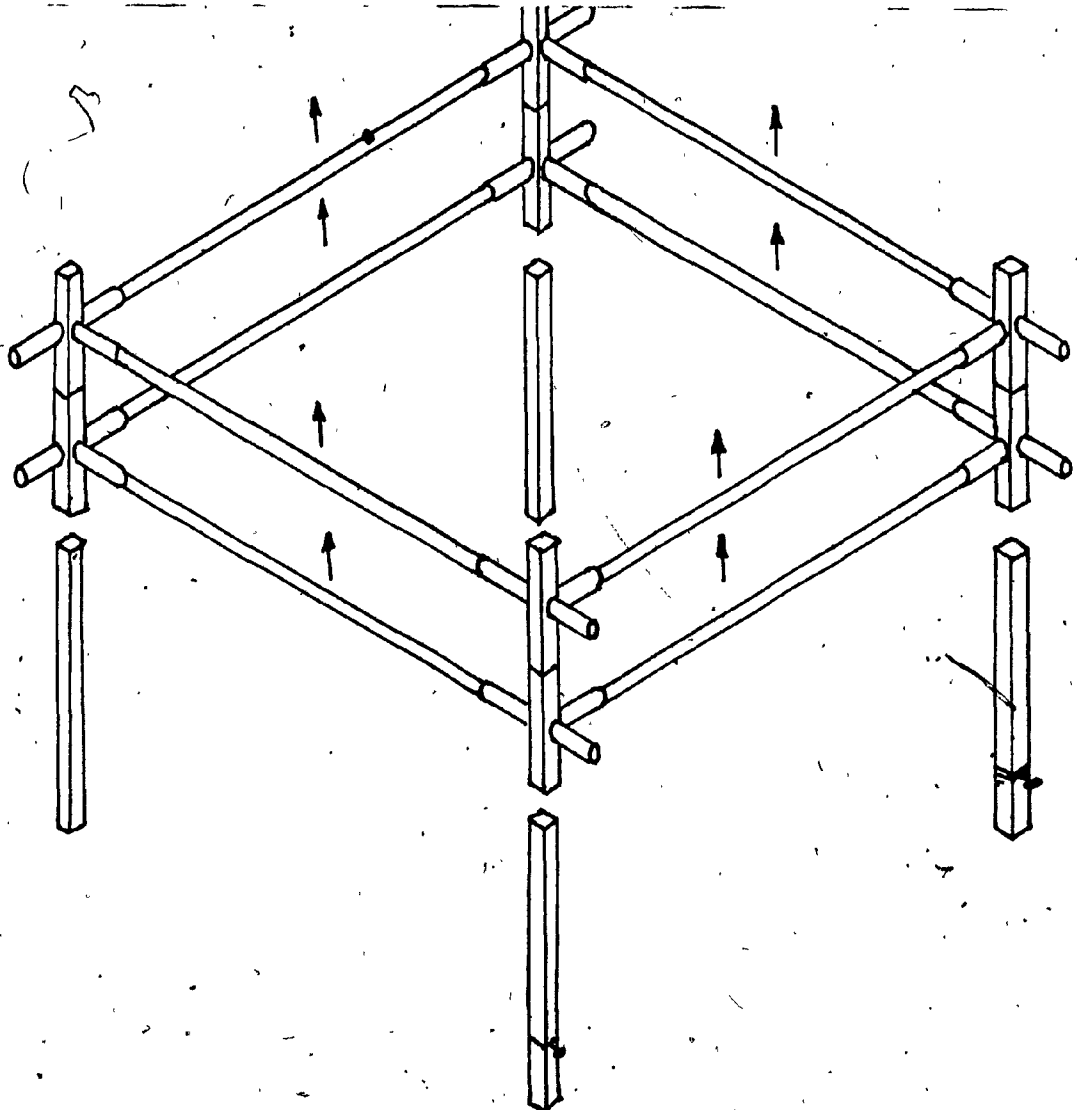

Fig. 3.23 - Removal of the Aluminium Frames

9. The whole process is repeated.

The result of the process is a series of steel tubes driven in the ground, positioned at the corners of the modular grid.

The basic idea is to have the initial precision, provided by the first two tubes, spread through the site. An example will clarify the concept and procedure.

The design solution is presented below:

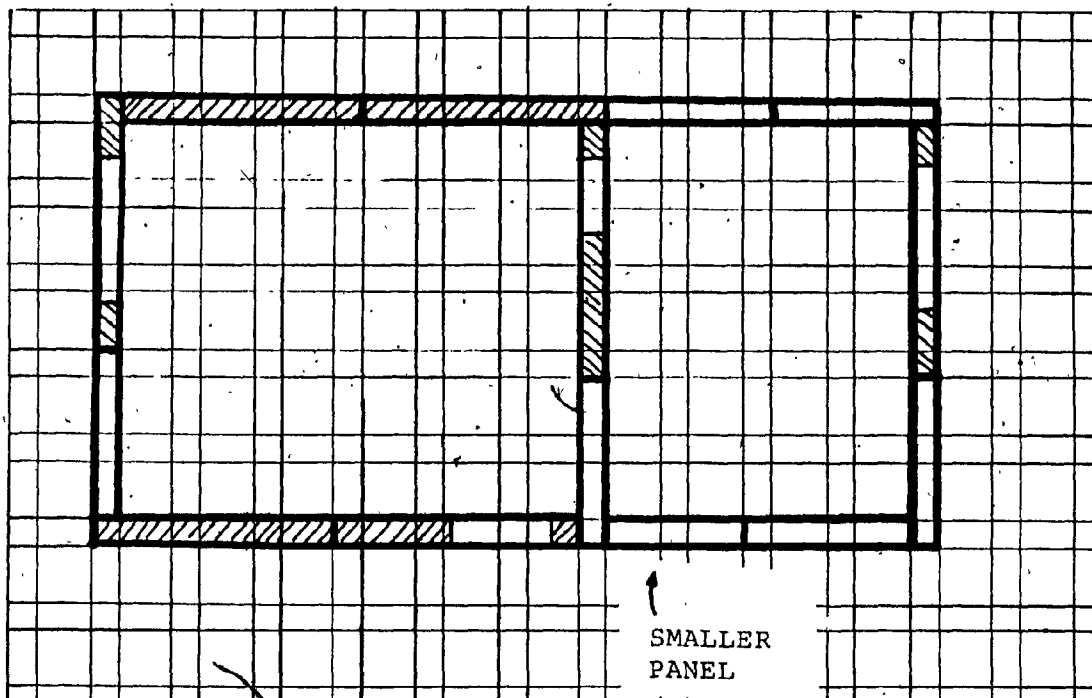

Fig. 3.24 - Design Solution

The first two tubes, which are located in a conventional way, have the numbers 1 and 2 (see following figure). The next tubes are located according to the procedure described before. The distance between the tubes is equal to the size of the panels, represented by the different colours. The sequence is presented in the following figure.

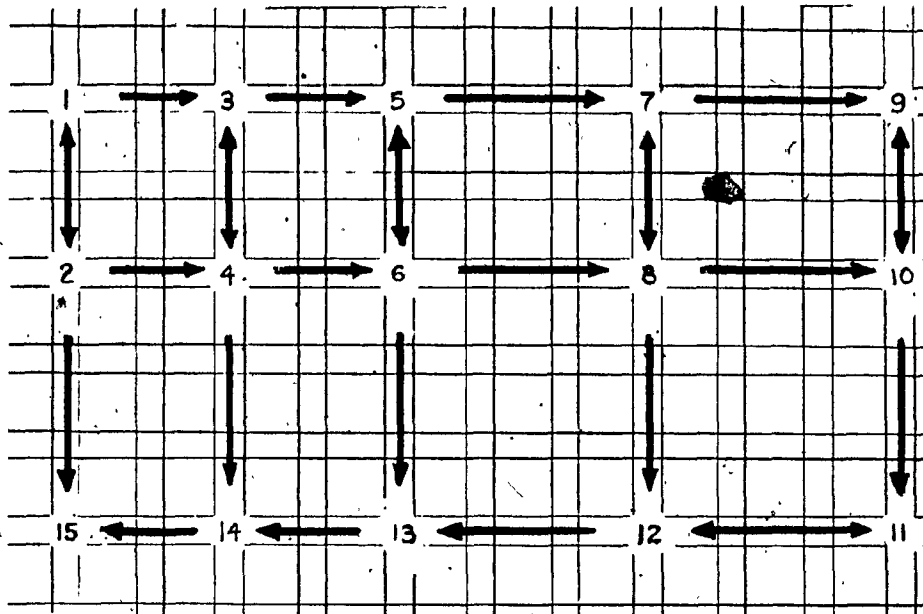

Fig. 3.25 - Sequence Adopted to Locate the Nodes

Tubes #4 and #8 are removed after the location process is finished, since they are located in the middle of the rooms and serve only to transmit the precision to the next tubes.

When the site is sloped, special care has to be taken. In such cases, the first two tubes must be located in the lowest part of the perimeter (see following figure). The distance between the node and the ground must be around 15 cm for the first two tubes.

For the subsequent tubes, this distance decreases. When it reaches between 0 and 5 cm, the upper frame becomes the lower one, and the steel tubes are positioned 15 cm higher. This is shown in the figure below:

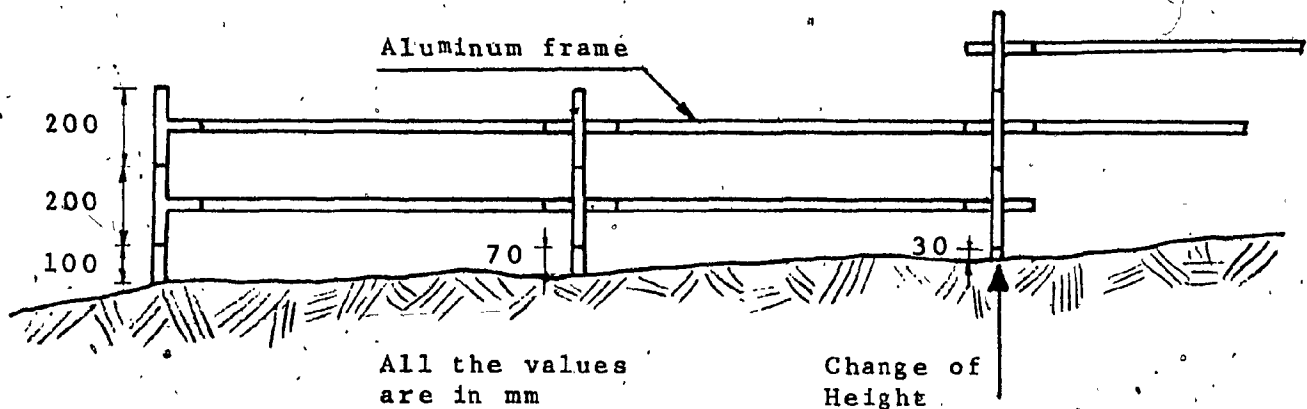

Fig. 3.26 - Change in the Height of the Aluminium Frame

To keep all the steel tubes the same height, the higher tubes must be further driven after the upper frame is removed.

If that original height is necessary for the location of the other tubes (as could be the case of tubes #6 and #8 to locate tubes #12 and #13), a piece of the same tube can be added on the top of those tubes. This piece is removed later.

The locating system proposed above has some limitations. Because the steel tubes are driven into the ground, rocks must not be present in the soil in the 50 cm depth, which would impede the penetration of the tubes. Fortunately, the ground in the Porto Alegre area is very suitable for such a system.

3.4.1.2 Field Experiment

It was decided to build the kitchen and the small bedroom at first, so that the family could move into it, and demolish the old house. This would provide the space to build the rest of the house.

The location of the house started by forming the house perimeter with the aluminium frame. This did not present any problem, since the self-helper had only to use the tubes with the same colour as on the drawing he made.



Fig. 3.27 - Self-Helper Forming the House Perimeter

The first two steel tubes were positioned by the author, helped by the owner. These were left for two days so that the soil-cement could reach adequate strength.

The location process restarted with the location of the next steel tubes. The self-helper rapidly understood how to use the aluminium frame. At the beginning, only one frame was used. However, due to the error generated, two superposed frames were adopted.

The procedure as described earlier was written out for the self-helper to facilitate his work. It seems that, since all the steps were in a logical sequence, he did not have much problem in learning the procedure. The only step the self-helper frequently forgot was the use of the supports to avoid further deflection in the aluminium tube. Also, care had to be taken when the steel tubes were driven into the ground. The self-helper had to stop hitting the tube when its top reached the top of the upper node, since the frame would not retain the steel tube, following it down and being deformed.

These problems were easily learned and the location of the first part of the house took no more than 7 hours.

The following figure shows the sequence adopted to locate the tubes:

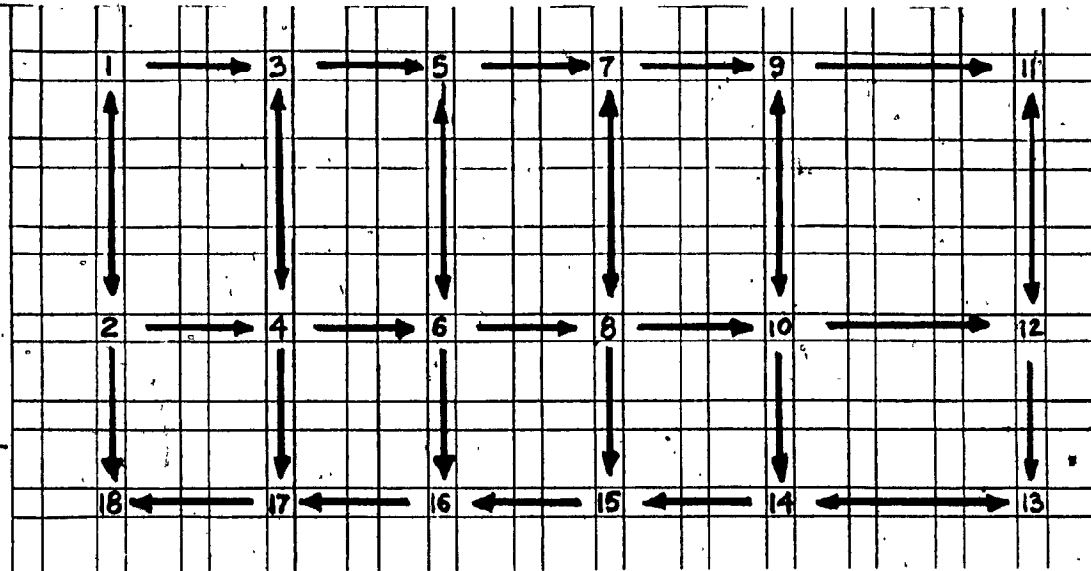

Fig. 3.28 - Sequence Adopted to Locate the Tubes

The following pictures show the self-helper locating the tubes:

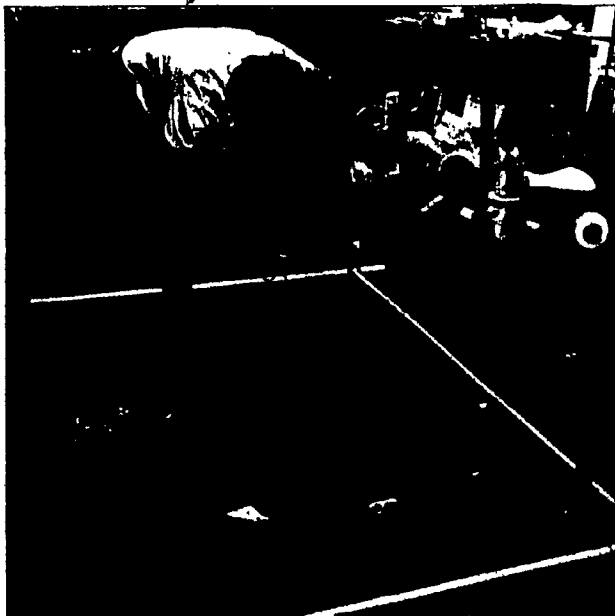

Fig. 3.29 - Self-Helper Executing Step #2



Fig. 3.30 - Self-Helper Executing Step #3

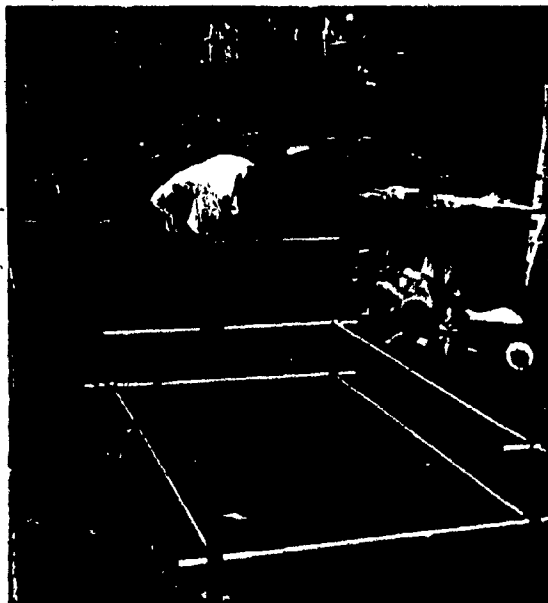

Fig. 3.31 - Self-Helper Executing Step #5



Fig. 3.32 - Self-Helper Executing Step #6

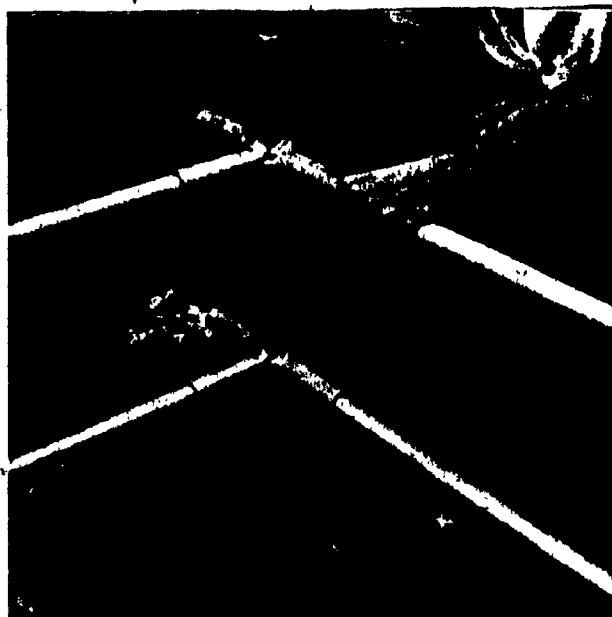

Fig. 3.33 - Self-Helper Executing Step #7

3.4.2 Foundation

3.4.2.1 Proposed System

3.4.2.1.1 Excavation

After all tubes are driven and the unnecessary ones are removed (tubes #4 and #8 in the example) the foundation is built.

The first step consists of opening holes along the rows of steel tubes. These holes do not need to have precise dimensions. The depth is related to the exposed part of the tubes: the hole must be deep enough to allow at least 60 cm of the top to stay uncovered. This measure is related to the height of the form that is going to be utilized, the top of which coincides with the top of the tubes. The worker should excavate until he finds a mark on the tube. That mark represents the 60 cm of the tube. The width of the hole must be around 60 cm. This measure is also obtained empirically by experimenting with the forms. The holes are of appropriate size when the forms can be placed in the right position.

The excavation can be done by any unskilled labour, using conventional tools.



Fig. 3.34, 3.35 - Excavation of Holes for the Foundations

The next step consists of constructing the foundation. For that, modular wooden forms are filled up with soil-cement, which is tamped until it reaches a good density.

3.4.2.1.2 Forms

The forms present the three sizes defined earlier (60, 120 and 180 cm), with a height of 55 cm. Plywood is sold in Brazil in sheets of 110 x 220 cm. If one of these

sheets is divided by its large axis, the result will be two pieces 55 cm wide. Since the only constraint, specifically related to the height of the forms is that it should not be greater than 60 cm, ⁽²⁾ this 55 cm was adopted.

These dimensions must also be checked against ergonomic considerations, which impose constraints on the weight of such forms.

A reasonable upper limit for man's lifting capacity is 30 kg. The following table provides the weights of various form sizes:

CORR. MODULES	SIZE OF THE FORM (cm)	APPROXIMATE WEIGHT (kg)*	
1mM	60	10.6	* Considering specific wooden form design
2mM	120	19.3	
3mM	180	28.0	

Table 3.3 - Dimensions and Corresponding Weight of Forms.

According to this table, the maximum size of a single form would be 3mM (180 cm). If a larger form were to be used, it would weigh around 40 kg, being 2.40 m long. Such weight could not be lifted by a single person, and to require more than one person to lift the form would go against the basic concept of having a self-help technique with a minimum of outside labour.

Ergonomic considerations also raise the question of man's capacity to handle objects. This capacity decreases with the increase of the size and weight of the equipment. The author's experience has shown that the workers manifest a greater difficulty to locate the 180 cm (3mM) form than to locate the 120 cm one. Certainly, a 240 cm (4mM) form would bring much more difficulty to such a task.

The forms are positioned through specially designed steel devices, which connect them to the tubes.

To provide lateral rigidity to the forms, wood profiles are nailed laterally on them. At the edge of these profiles, flat iron bars are screwed. All those details can be seen in the following figures:

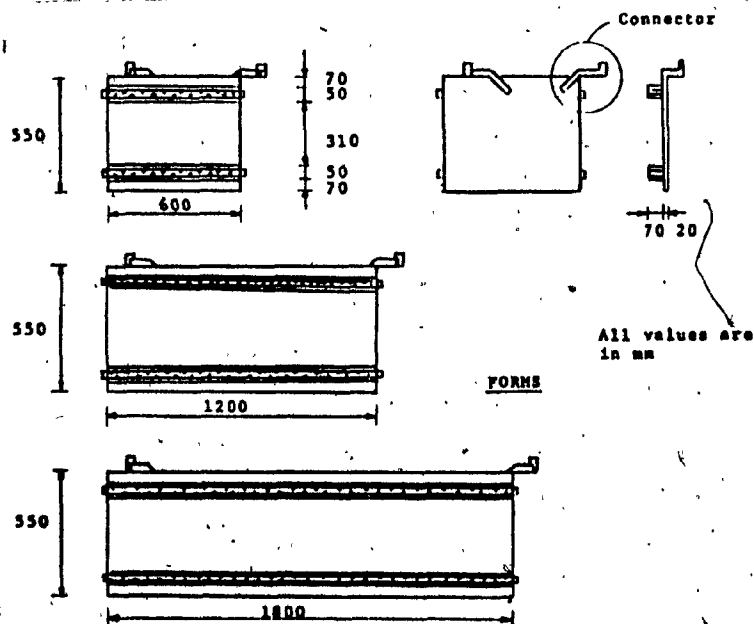
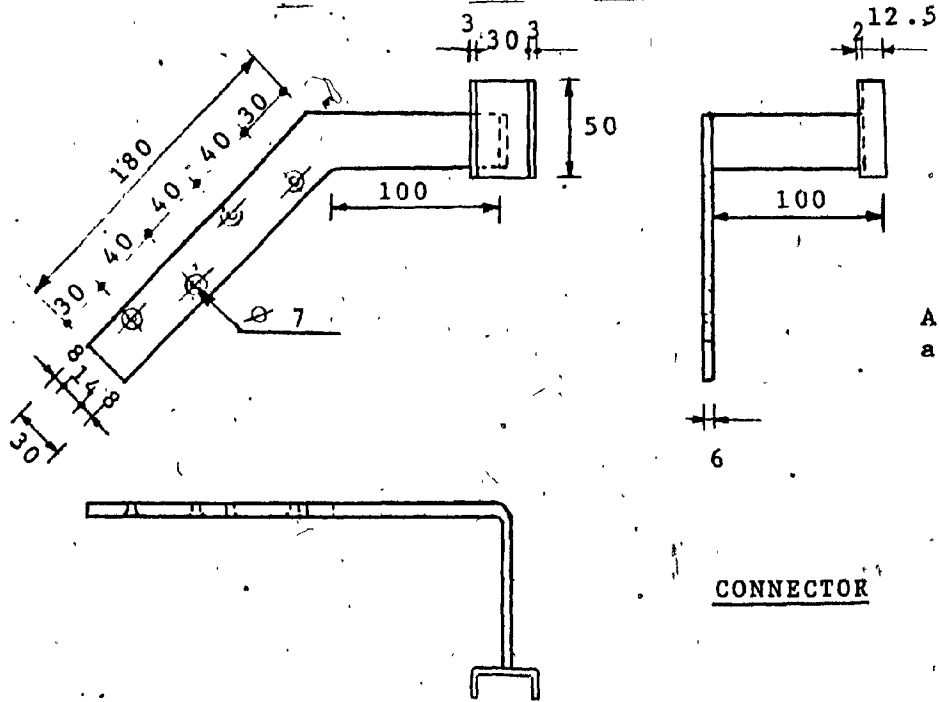

Fig. 3.3.6 - Forms



All the values are in mm

Fig. 3.37 - Connectors

The walls are 20 cm thick, while the foundations are 35 cm thick. To obtain these wider foundations with the same set of forms, special spacers are used (see following figure).

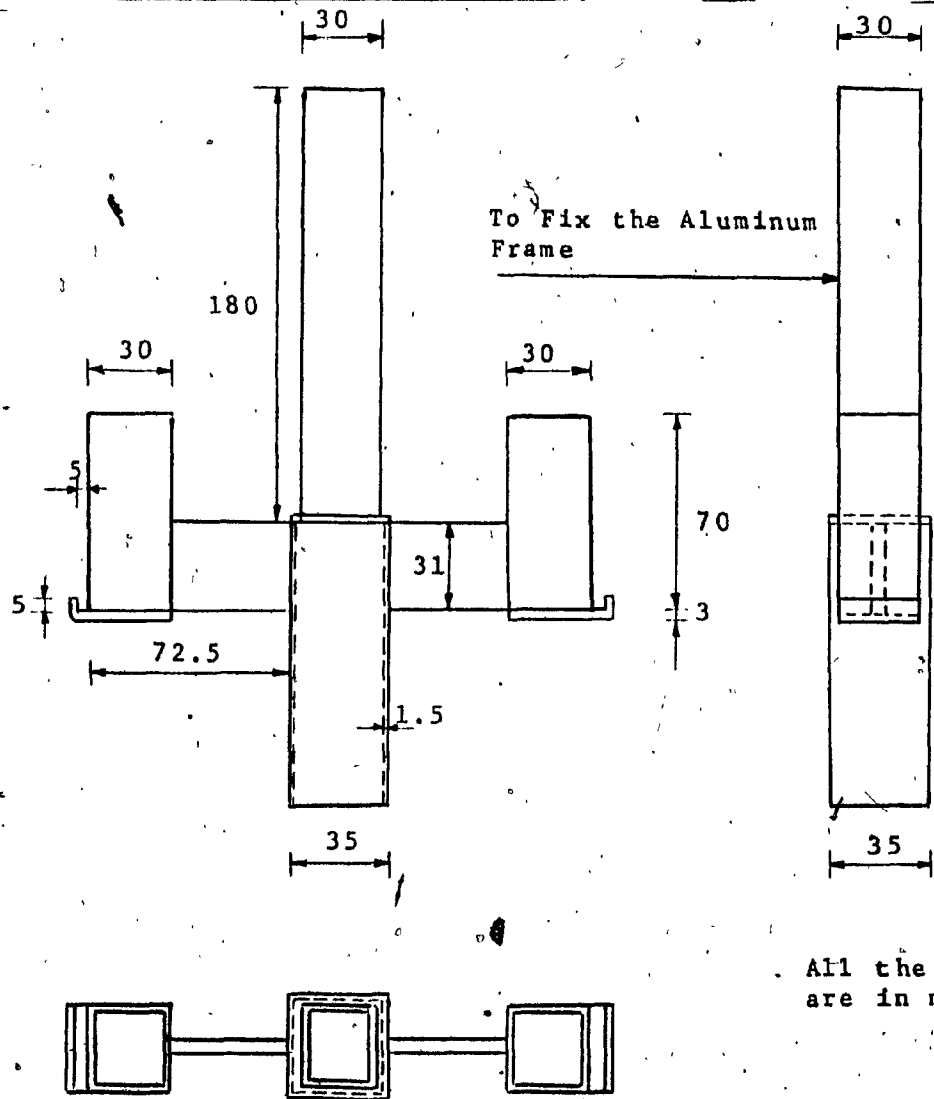

Fig. 3.38 - Spacers

The locating system composed of steel tubes, connectors and spacers, positions the forms in the right place, but does not hold both sides together.

To perform this function, different solutions can be adopted. The author chose one based on his own experience.

It consists of four iron bars which pass through the iron bars, screwed on the form at both extremes. A pin holds these bars together, preventing them from moving. The system is represented in the figure below:

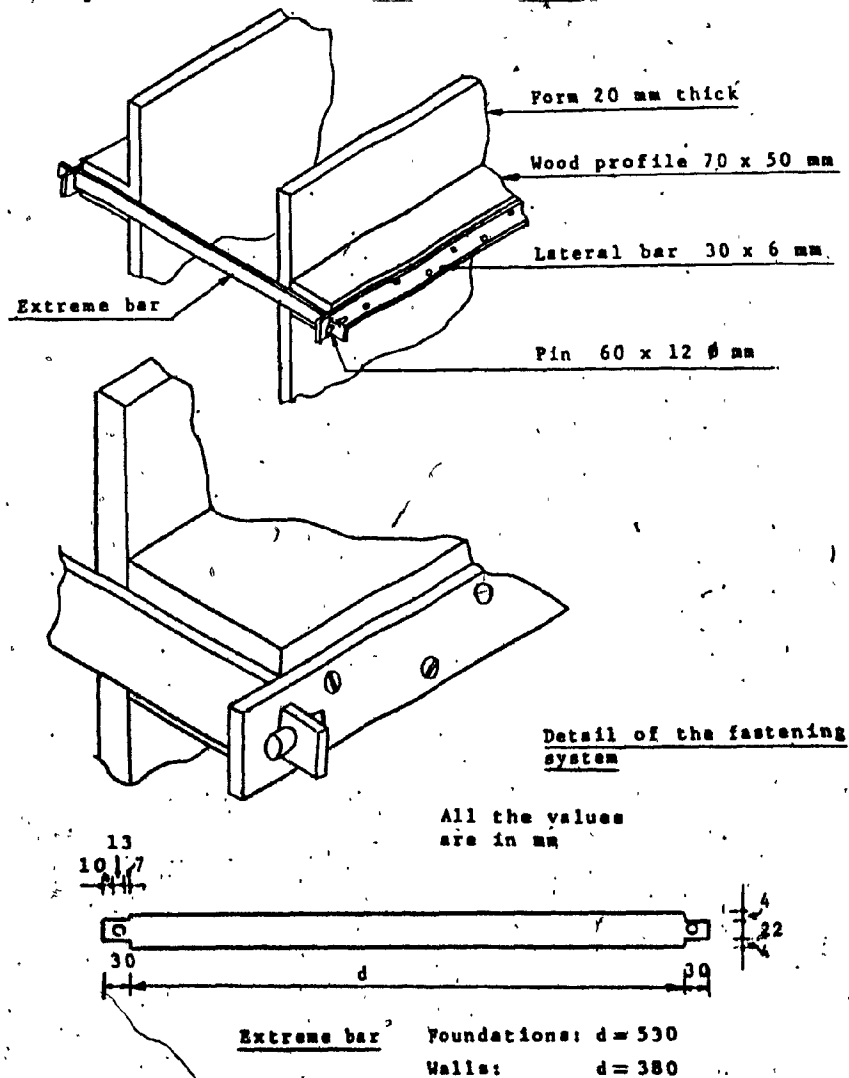
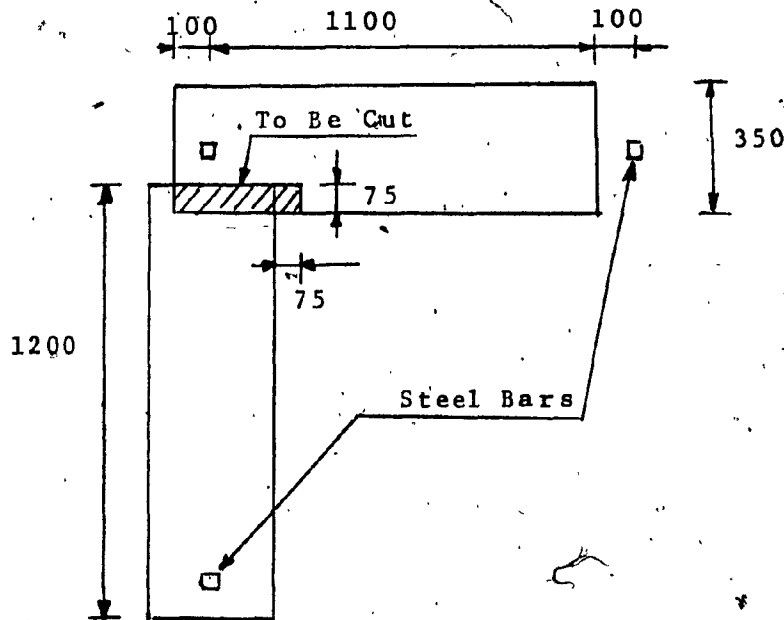

Fig. 3.39 - Fastening System Adopted

When the system is used for the walls, there are no problems. However, for the foundation, the overlapping of blocks is unavoidable, and some part of the already built foundation has to be cut.

The overlapping problem is shown in the following figure:



All the values are in mm.

Fig. 3.40 - Overlapping of Foundation Blocks

This type of problem is likely to occur four or five times during the construction of the foundation.

The mounting of the forms for the foundation is extremely easy. The whole procedure is presented in steps:

1. The expanders are fixed, so that the foundation will be 35 cm wide.
2. The forms are connected to the expanders. When the forms are connected, they are automatically level,

squared and dimensioned.

3. The lateral flat bars are fixed and the pins are fitted. The forms are plumbed.

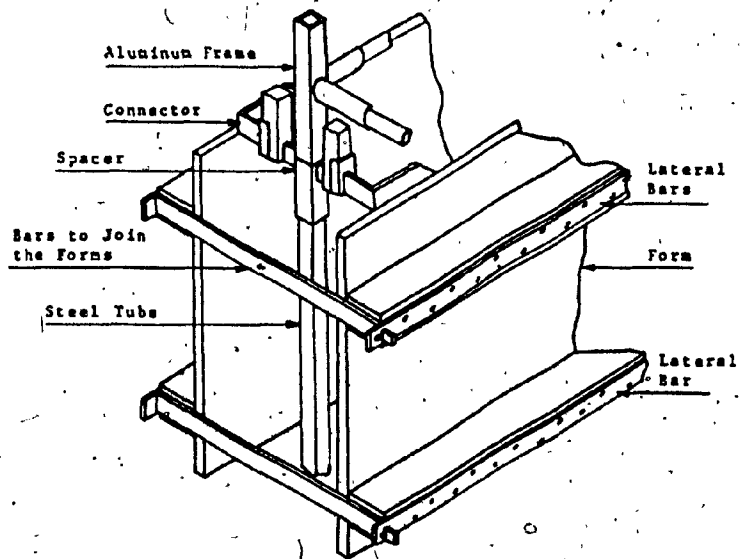

Fig. 3.41 - Form Mounted for the Foundations

4. Lateral wooden forms are mounted to avoid the soil-cement from flowing out of the form.

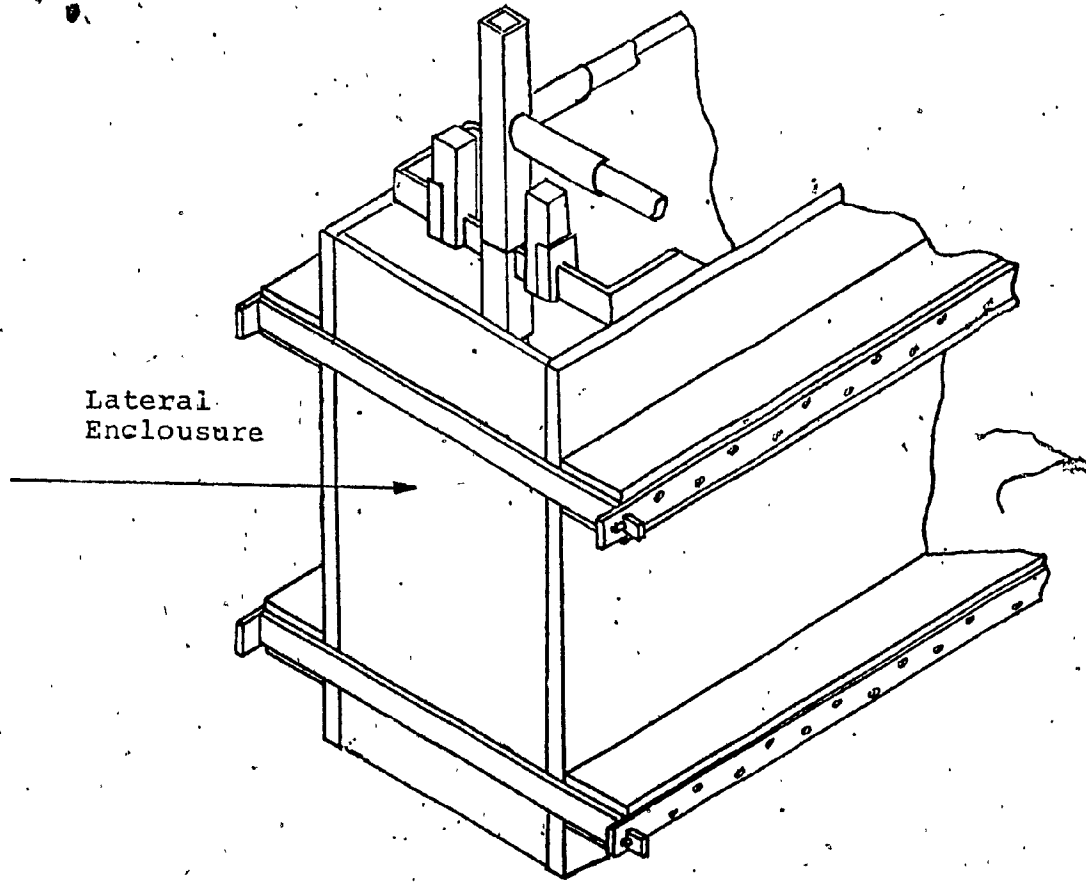

Fig. 3.42 - Forms Ready to Cast a Foundation Block

This procedure can be executed by only one person, but there is room for two persons to work.

There are various reasons to adopt wider foundations:

- the soil support capacity: when tests are not run to determine this capacity, it should be adopted as

50 kPa. The weight of the wall, plus roof, plus accidental weight is about 1.5 tonnes per metre, which requires a minimum foundation width of 30 cm;

the location of the forms: the bottom of the forms is loose, which may produce a small lateral inclination when the soil-cement is poured and tamped. For safety reasons, the foundation should be larger than the wall to neutralize this deviation from the vertical axis (see figure below);

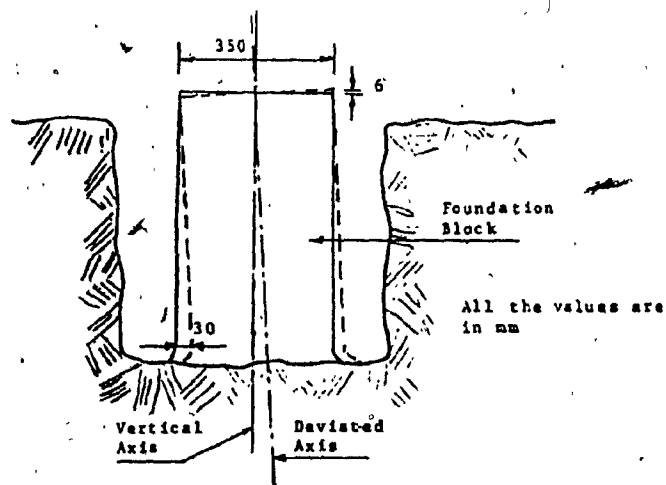

Fig. 3.43 - Deviation of the Foundations from the Vertical Axis

the difference of width between foundations and walls is used to level the floor (see following figure);

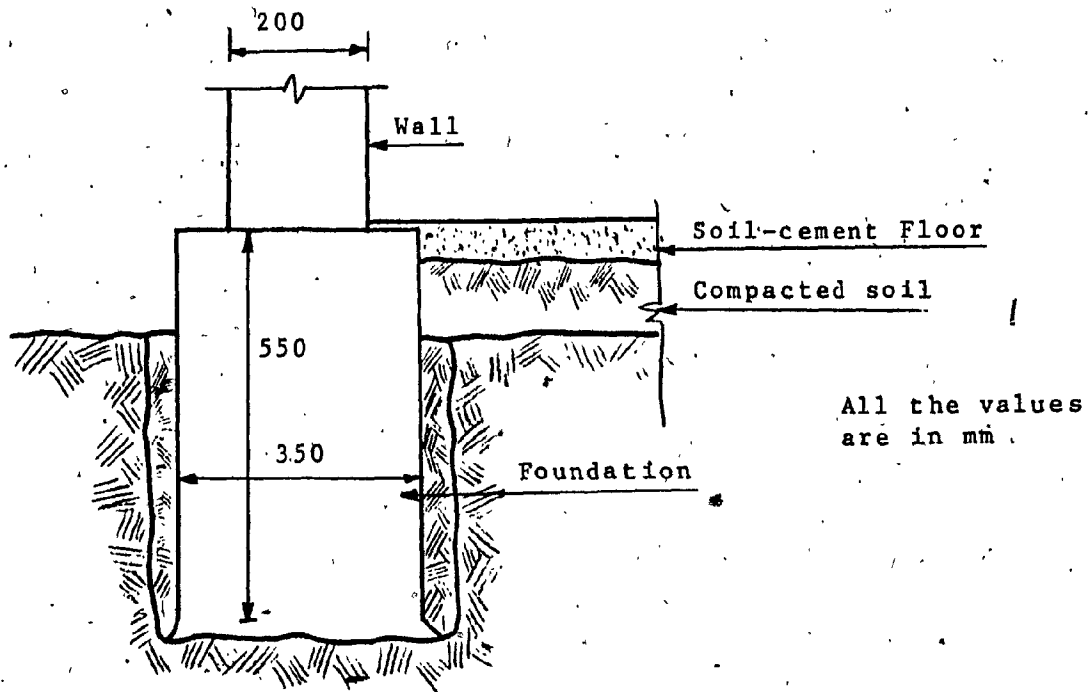

Fig. 3.44 - The Floor Level is Based on the Difference Between the Foundation and Wall Widths

8.4.2.1.3 The Use of Soil-Cement

The theoretical aspects of the use of soil-cement were already discussed in Chapter II. The important issues in this chapter are related to the practical use of it, more specifically, how it is prepared and how it is applied in walls and foundations.

The first steps are related to the selection of the soil to be used and the laboratory test to determine the correct cement percentage.

After the correct proportion between soil and cement is defined, it is necessary to make such results useful in the field. The problem with correct dosage of cement is always present. To solve such a problem, pre-designed containers for cement and soil dosage based on volume must be provided. It is preferable to utilize absolutely distinctive containers - preferably one much larger than the other.

The way of mixing is similar to concrete: the soil is brought to the place where it is going to be mixed. If it is manual mixing, the soil is laid on the ground, preferably on some protective material to avoid its mixing with common organic soil.

The cement is dropped onto the middle of the soil. The best way to ensure a reasonable control of quantities is to require the workers to fill the containers (normally wooden boxes) to the top, without tamping the material.

The soil and cement are mixed with conventional equipment and the water is added little by little. The correct amount of water is determined by feeling. The mixed material must be mouldable when pressed by hand, and break in few parts when dropped to the ground. (3)

The control over the amount of water used by quantity is much more difficult, due to variations in the humidity of the soil used.

The mixing procedure stops when the cement cannot be seen distinctively anymore. It is also important to break any soil balls which already existed, or which are formed when water is added. When the form is mounted and the soil-cement is prepared, the soil can be poured into the forms and tamped.

3.4.2.1.4 Tamping Procedure

To ensure that the top of the iron tubes are in the right position, the aluminium structure should be used again, as is shown in the picture below:



Fig. 3.45 - Use of the Aluminium Frame to Keep the Steel Tubes in their Correct Position

To tamp the soil-cement in the form, a special tool is used. It is shown in the following figure.

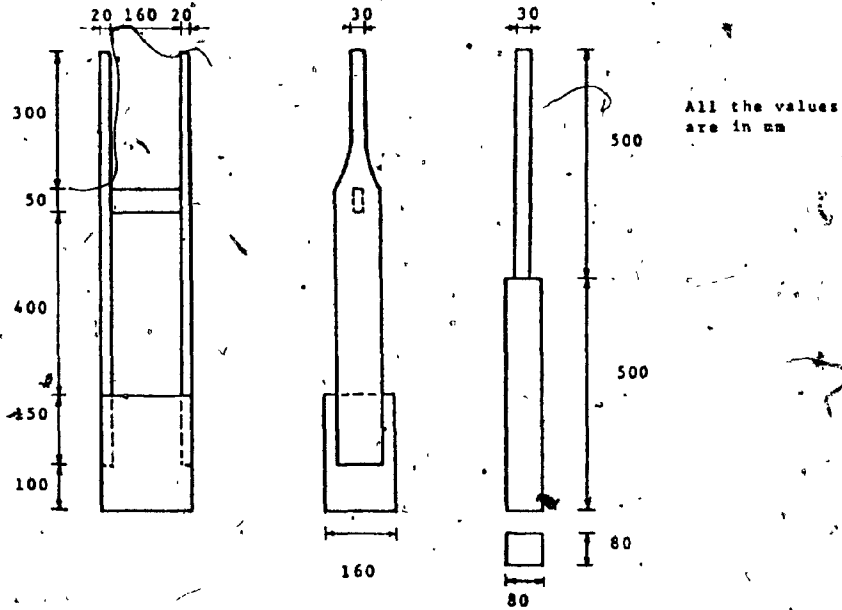

Fig. 3.46 - Tampers

These tampers are used with both hands. The worker makes a vertical movement, holding onto the top of the tool. The up and down movements must not be very fast because, otherwise, the worker will get tired very quickly. The movement must be rhythmic.

The following picture shows a worker using the tamper.

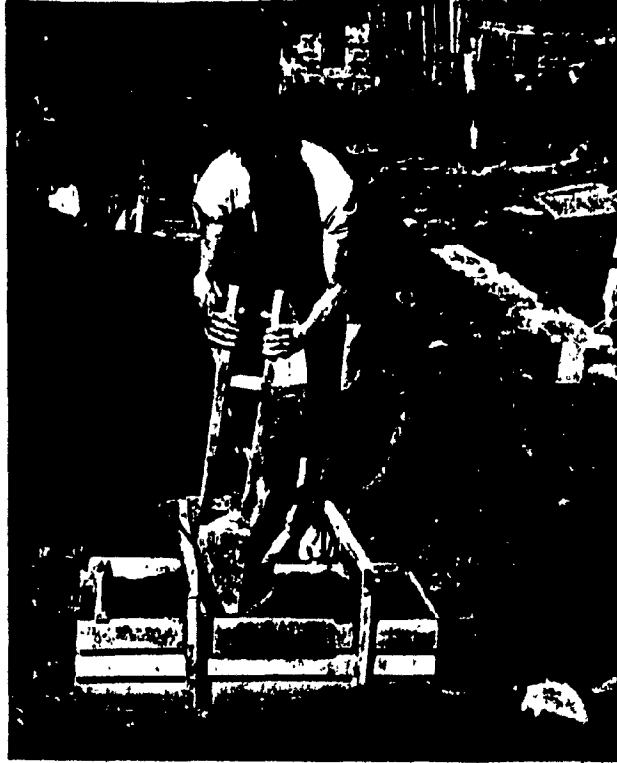

Fig. 3.47. - Worker Using the Tamper

One of the problems with tamping soil-cement in the field is to know when the material reaches a good density; in other words, when the workers should stop tamping. The author's experience showed that the material has reached the right density when it produces a "solid" massive sound. In opposition, when the correct density has not yet been reached, the sound is "soft" and almost nonexistent. This feeling of when the soil is dense enough is easily acquired. It can also be checked by scratching the surface of the compacted material with a sharp metal device. If this scratching

produces thin and clear lines, the material is well-compacted. However, if it produces an undefining line, breaking the material while moving, that is a sign that it is not well-compacted.

The soil-cement must be dropped in the form in layers of no more than 20 cm of soft material. If a layer thicker than that is compacted, its lower part will not be well-compacted and will disintegrate very easily.

When the forms are full of compacted soil-cement, they can be removed immediately. The soil-cement block stands without any deformation. However, it cannot be loaded or struck, since its resistance is only due to the compaction of the soil and not to the cement added to it. The procedure presented above must be repeated until all the foundation blocks are cast.

3.4.2.2 Field Experiment

After the steel tubes were in place, the foundation started. The self-helper was asked to excavate between the iron tubes, so that the forms could be used as shown before. The first hole between two tubes took a longer time, since the self-helper did not know its correct size. However,

the remaining excavation was done at normal speed, without any further problem. The forms were always tested between two tubes to ensure that the hole was large enough. This task took three weekends.

Casting the foundation blocks was started on the following weekend. The boxes used to measure the soil and cement quantities were built and the mixture prepared. (*) It took between 10 and 15 minutes for one person to prepare the mixture and between 7 and 12 minutes for two persons. Three mixture cycles were necessary to fill the 2mM form and five to fill the 3mM one.

The mixture was carried in the larger box to the forms and dropped in to be tamped. Tamping took between 5 and 7 minutes in the 2mM form, and 7-10 minutes in the 3mM form.

3.4.2.2.1 Fastening Systems

The time required to fix the form varied according to the fastening system used. During the entire construction phase, four systems were tried. They were:

(*) See Appendix: DETERMINATION OF THE SOIL-CEMENT TRACE: LABORATORY AND TEST RESULTS

1. Bolt Fastening: Bolts were used to hold the forms together, as in the case of the form for the roof structure. Two main problems arose with this system - it could not be used for the foundations since it was impossible to remove the bolts after the blocks were cast. Another problem was that the bolts were too susceptible to damage when in contact with soil - their screws were damaged. Also, a finishing problem appeared due to the holes left.

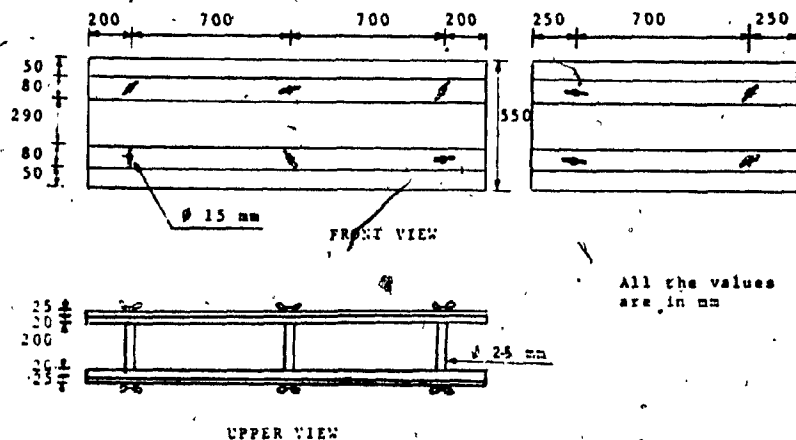

Fig. 3.48 - Bolt Fastening System

2. Clamp fastening: The clamps were "U"-shaped and held the forms together, according to the following picture.



Fig. 3.49 - Clamp Fastening System

The soil-cement, when compacted, created a pressure that deformed the clamps which had to be abandoned.

3. Pin fastening: This system consisted of flat iron bars screwed to the forms, connected by vertical pins to other bars at the extremes (see following figure).

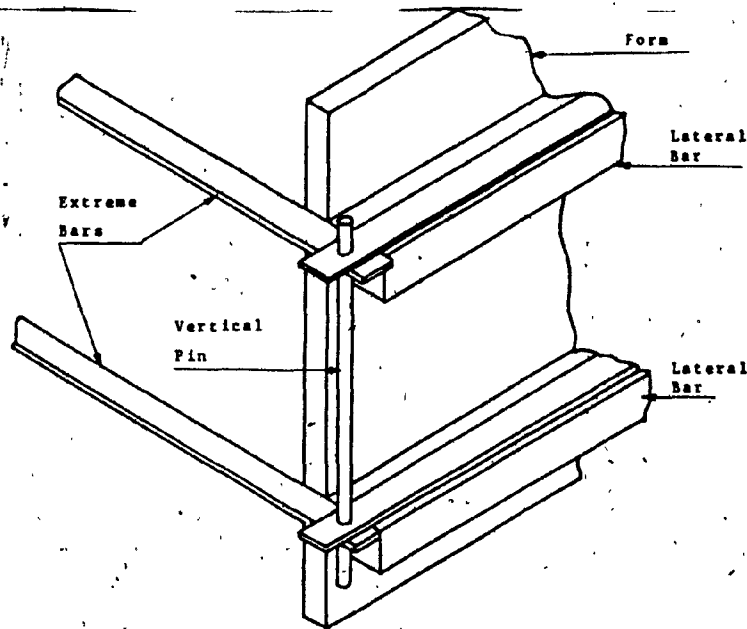

Fig. 3.50 - Pin Fastening System

The basic problems of this system were the difficulty in assembling and disassembling the forms (mainly at the corners), and the finishing problems, also at the corners.

4. Modified pin fastening: Some modifications in the pin system improved the assembling procedure and reduced the problem of finishing. Instead of large pins, small ones were used. Also, the bars were modified in this new system, as explained earlier.

However, this system was not used to cast the foundations, where the clamp system presented fewer problems.

A table with a more complete evaluation of the various systems is presented below. It shows that the last system used has the best performance.

CHARACTERISTICS	WEIGHT	BOELTS		CLAMPS		PINS		CHANGED PINS	
		Eval Value	Eval Value	Eval Value	Eval Value	Eval Value	Eval Value	Eval Value	Eval Value
Avoid Deformations	30	0.9	27	0.5	15	0.9	27	0.9	27
Easy to Set Up	15	0.3	5	1	15	0.7	12	0.9	14
Durability	20	0.3	6	0.6	12	0.9	18	0.9	18
Interference With Tamping	10	0.5	5	0.2	2	1	40	1	10
Finishing Requirements	15	0.5	8	1	15	0.2	3	0.6	9
Usable in the Foundations	10	0.1	1	0.9	9	0.3	3	0.5	5
TOTAL	100		53		68		73		83

Table 3.4 - Evaluation of the Various Fastening Systems

3.4.2.2.2 Productivity

After each block was cast, the forms were removed and fixed between two other tubes.

The whole process, including preparing the mixture, setting the forms, tamping and removing the forms could vary, depending on:

- the number of people involved in the process;
- the physical and emotional aptitude of workers;
- the fastening system used;
- the size of the form
- unexpected fixing problems.

For the foundations, this time variation is shown in the following table:

FORM SIZE	NUMBER OF WORKERS	
	One Person	Two Persons
2mM	1:15 - 1:40 h	50 min - 1:20 h
3mM	1:40 - 2:20 h	1:20 h - 1:40 h

Table 3.5 - Time Required to Cast the Foundation Blocks

The procedure to realign the top of the iron tubes was easily understood and followed.

At the beginning, forms 100.0 cm and 150.0 cm long were used, and columns had to be cast between the blocks. However, it was difficult to fix the forms for these columns and to cast them, since the large tamper could not be used. This system was later abandoned in favour of larger forms (120.0 cm and 180.0 cm).

3.4.3 Walls

3.4.3.1 Proposed System

The procedures applied in the foundation are used for building the walls. The material is the same, as well as the equipment. The only difference lies in the thickness of the wall, which is 20 cm. To obtain this thinner wall, the worker has only to mount the forms, connecting them directly to the steel tubes, without using the spacers.

To guide the forms, the steel tubes are extended up to the final height of the wall. This extension is provided by a piece of wood which fits tightly inside the steel tubes. Half of this piece is inserted in the lower segment and half in the upper segment (see following figure).

To ensure that the tubes are in the correct position, the aluminium frame is mounted again on top of it.

The wall is built in blocks, with 47 cm height, except the lowest one. The smaller courses come from the need to

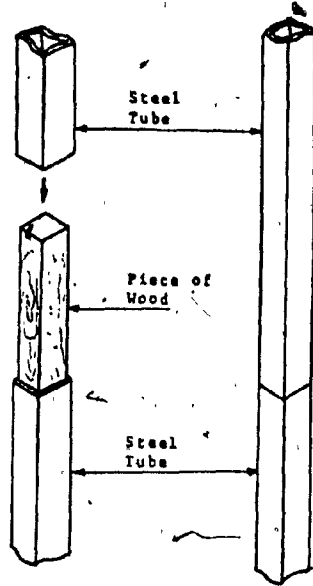

Fig. 3.51 - Piece of Wood Used to Extend the Tubes

support the form. To do that, the lateral flat iron bars lay on the lower block, preventing the upper one from moving down. While the bars were not in place, steel bars held the forms. This is shown in the following figure.

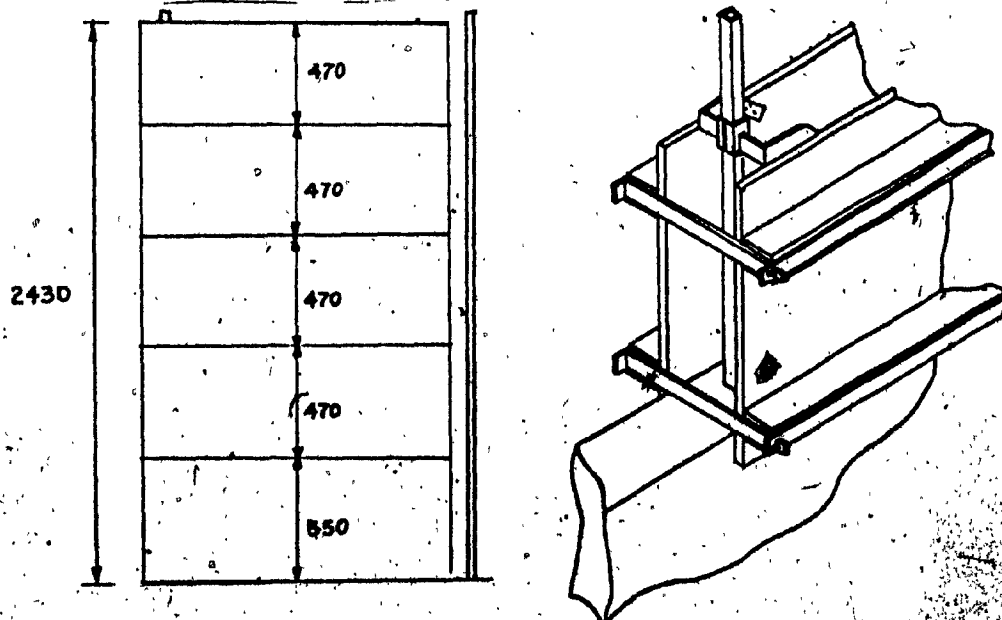

Fig. 3.52 - Block Height and Support to the Forms

The total height of the wall is 243 cm, corresponding to 5 courses of soil-cement.

When building the walls, the correct order of casting the blocks should be observed. In the corners, the block which includes the corner must be built first. This is shown in the following figure.

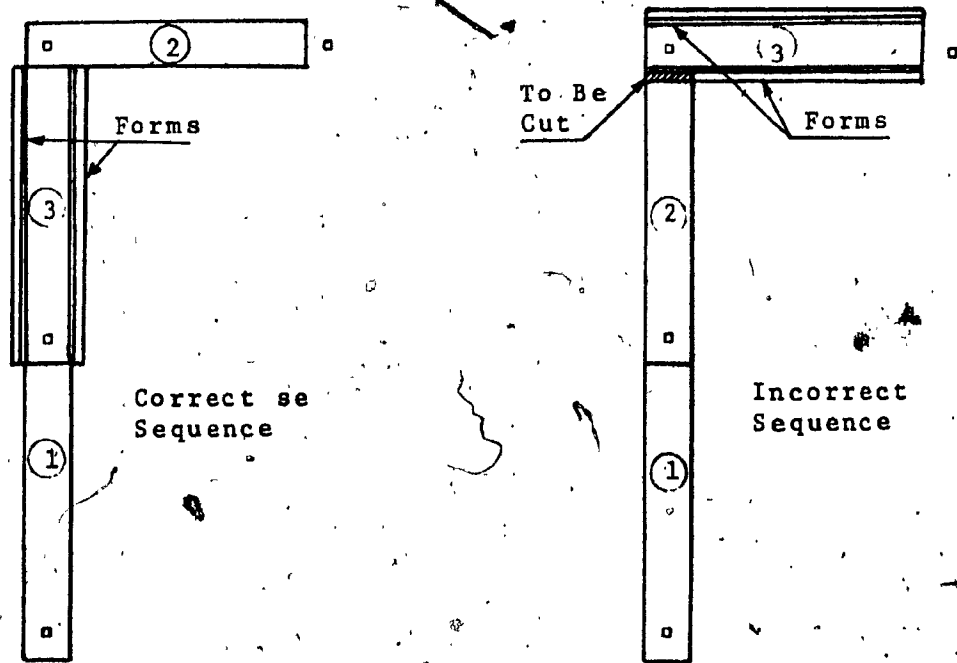

Fig. 3.53 - Correct Sequence of Casting the Blocks

In the incorrect sequence, part of the block #2 has to be destroyed to allow the form to be installed for block #3. In the correct case, there is also some damage to the previous block, but this is not a major problem.

When the blocks are being built, after a layer is tamped, its upper surface must be scratched with a sharp metal to provide asperity to the surface and improve the bond.

The use of forms provides a good solution for the problem of precision. Since soil-cement is an amorphous material, all its surface points must be precisely located (according to the principle stated at the end of Chapter II). This location is provided by the internal surfaces of the forms. The solution does not require further surface treatment to obtain a smooth wall. When the form is removed, the surface is ready to be painted.

3.4.3.2 Field Experiment

After the foundations, the walls were cast. At first, steel tubes were extended 1 m, and the aluminium frame fixed.

The access to the whole site was possible by not casting two wall segments, as shown in the following figure:

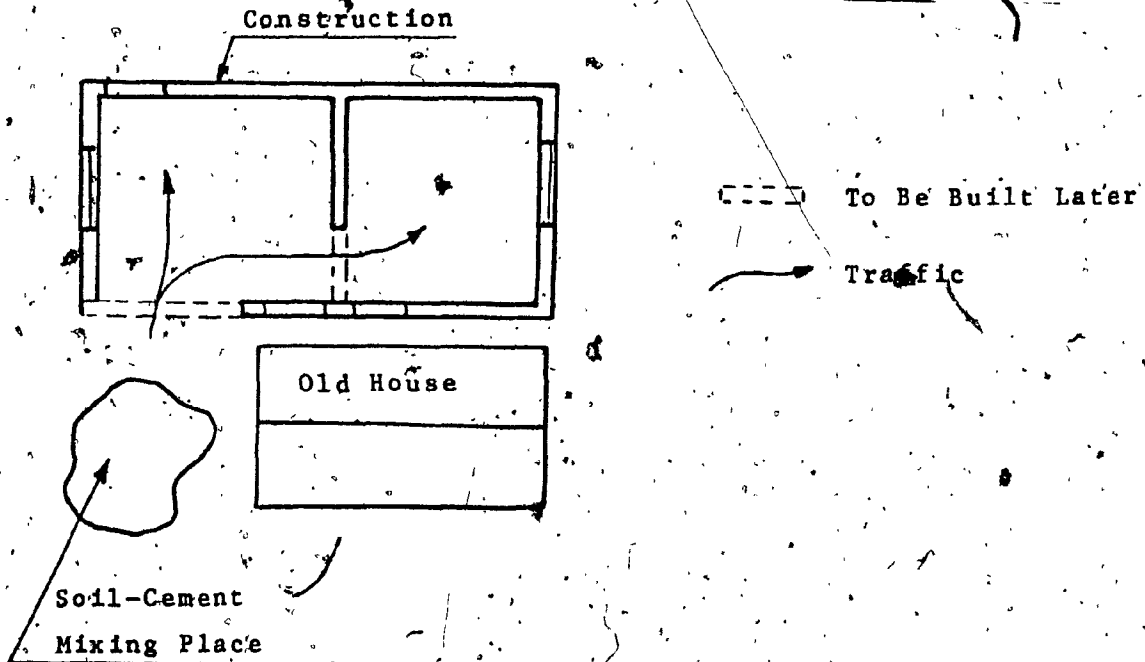

Fig. 3.54 - Sequence of Casting Adopted to Allow Access to the Various Points of the House

At first, the bolt and the clamp fastening systems were used. However, they had to be abandoned due to the problems with the tamping procedure. Then the pin system explained previously was adopted.

The time required to build one block varied. The reasons for this variation were the same as those explained for the foundations, with the addition of the height of the blocks: the higher blocks took more time. The walls took less time to cast, since they were thinner. The variation of time is shown in the following table.

FORM SIZE	NUMBER OF WORKERS	
	One	Two
2M	1:00 h - 1:30 h	40 min - 1:00 h
3M	1:20 h - 1:50 h	1:00 h - 1:20 h

Table 3.6 - Time Required to Cast the Wall Blocks

During the construction of walls, it seemed that it was necessary to find an aid to speed up the construction process, since it was taking place only on weekends.

To solve the problem, a labourer was hired and the self-helper was paid Cr\$7,000.00 (\$110.00). The important question was to know if the payment to the self-helper would not spoil the whole experiment. To do so, it was necessary to look at the goals which were to be achieved and analyze how they would be influenced.

The goals were to develop a technology which could be understood and absorbed by the self-helper. The question of whether or not he would abandon the program in case of working only on weekends could not be answered. However, it was not the proposition of the experiment to measure the self-helper's capacity to maintain his interest in the process (such evaluation would require a much larger project, to work on statistical values).

The soil used in the foundations and walls also deserves some consideration. At first, the intention was to use the soil obtained in the site and vicinities. However, there were problems related both to the volume of earth involved and to the quality of the soil, in which organic matter was found, even in samples taken from 1 m depth.

To neutralize such organic matter, so much cement and lime would be required that it was found to be cheaper to use a better soil from another place a few kilometers from the site. Additional advantages were that the soil came ready to be used, while the local soil had to be broken down and pulverized before it could be used, and the site was not damaged by removing a large amount of earth.

The earth brought from the other place presented some variations in colour (due to different clays) and granulometry. It was yellow, when montmorillonite clay $\text{Ae}_2\text{Si}_4\text{O}_{10}(\text{OH})_2$ was present, and pink when kaolinite clay $\text{Ae}_2\text{O}_3 \cdot 2\text{SiO}_2 \cdot 2\text{H}_2\text{O}$ was present. The first one tended to absorb water and swell very easily, so that the pink soil was found to be the better one. These considerations were confirmed on the site, where the stronger blocks, with a better surface, were made out of the pink soil.

The precision of the walls was very good, as shown in the following picture.



Fig. 3.55 - Soil-Cement Wall

To obtain a good finish, three points were found to be very important:

- the amount of water used during the mixing process;

- the quantity of soil-cement poured into the forms for compaction; and

- the compaction process.

The amount of water used for mixing was very important to the resistance of the material and the surface. At first, the common procedure described above was used to determine the correct amount of water to be used. It could not provide a precise measure, but was considered to produce good results. After a while, larger amounts of water were used. The main consequences were a block with no great decrease in resistance, but with a smoother surface. It was also observed that, if the forms were removed immediately after the block was cast, the surface was not as smooth as when the forms were kept in place for at least 6 hours.

The amount of soil poured could not surpass 25 cm height. When that happened, the lower part of that layer became badly compacted and, as a consequence, friable and easily erodable.

The compaction also had an enormous importance for the quality of the final material. If the mixture was not compacted enough, again the surface became friable and erodable.

The last comments on the construction of walls refers to the way the mixture was poured into the forms. For the

two lower courses, it was possible to use the same box used to carry and measure the soil. However, for the higher ones, it was necessary to use a bucket, which diminished the productivity.

The pictures below show the walls built in the experiment.

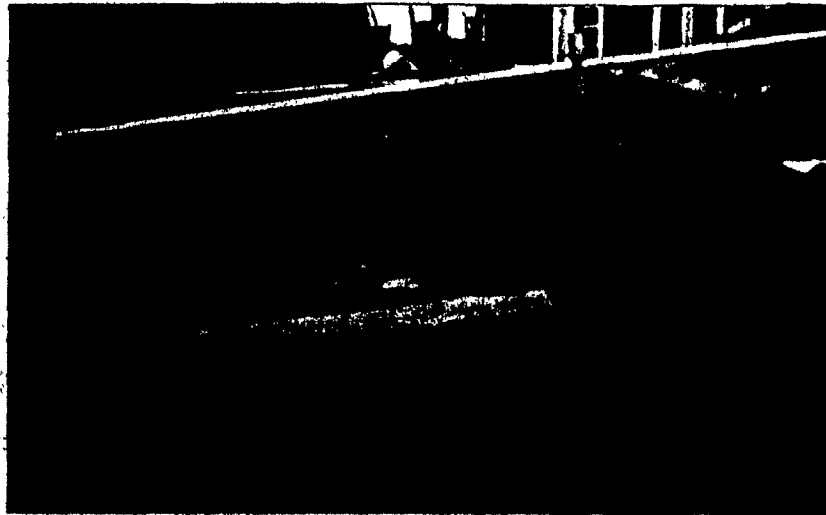
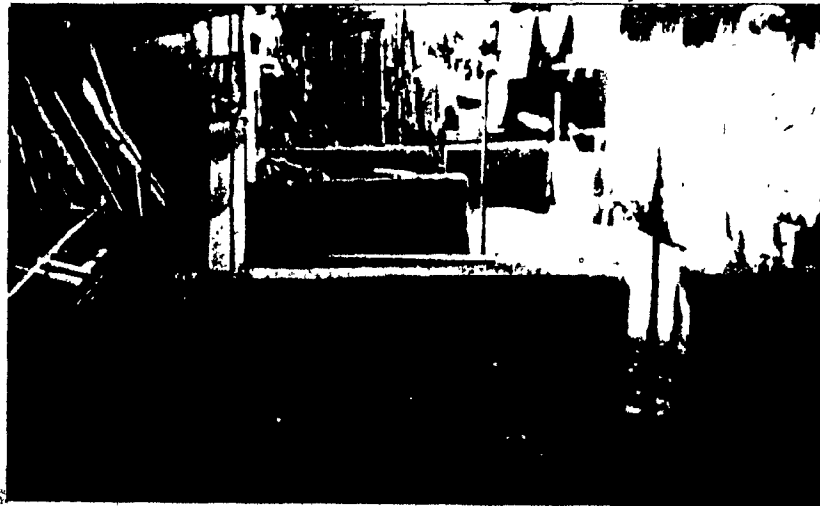

Fig. 3.56, 3.57 - Soil-Cement Walls Built in the Experiment



Fig. 3.58 - Self-Helper Filling a Form
Using a Bucket

3.4.4 Openings

3.4.4.1 Proposed System

The frames in the openings are not fixed in place during the casting of the blocks. To obtain an open space in the wall, a wooden dummy with the same size as the window and the same thickness as the wall is fixed together with the forms. When the soil-cement is poured and tamped, it surrounds the dummy, providing the required space. The dummy is levelled by the course below it, just by laying on it. Since the upper

surface of the blocks is levelled, the dummy becomes automatically levelled, too. The forms compress the dummy keeping it plumb and not allowing it to move. The dummy is braced to avoid deformation due to soil pressure.

It is interesting to note that the system does not impose a specific window size, in spite of the modular wall system. Any window size can be used between two consecutive steel tubes, leaving only 15 cm at each size, to avoid too weak a wall segment or interference with another block (see following figure).

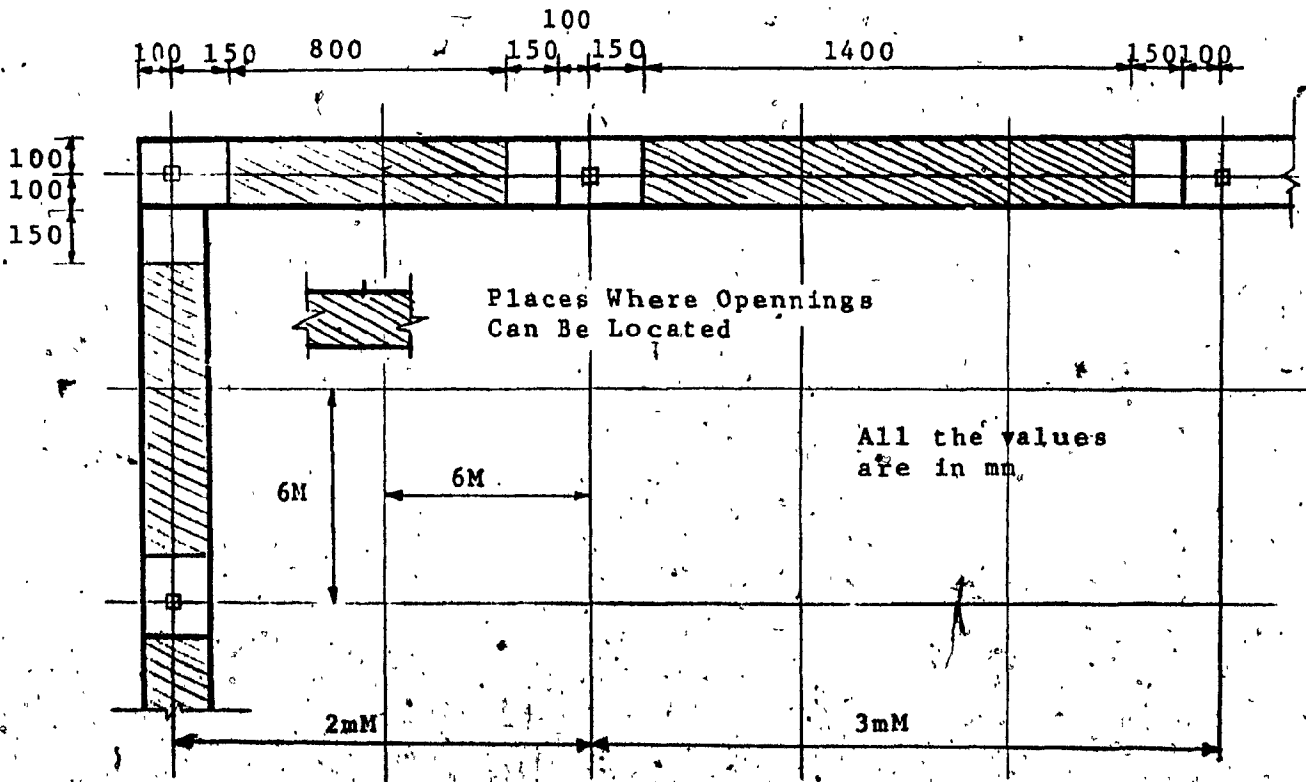

Fig. 3.59 - Location of Windows and Doors in the Walls

This flexibility in window and door sizes is extremely important, because many times these people obtain second-hand doors and windows with random sizes.

The following figure shows a window dummy already in place.

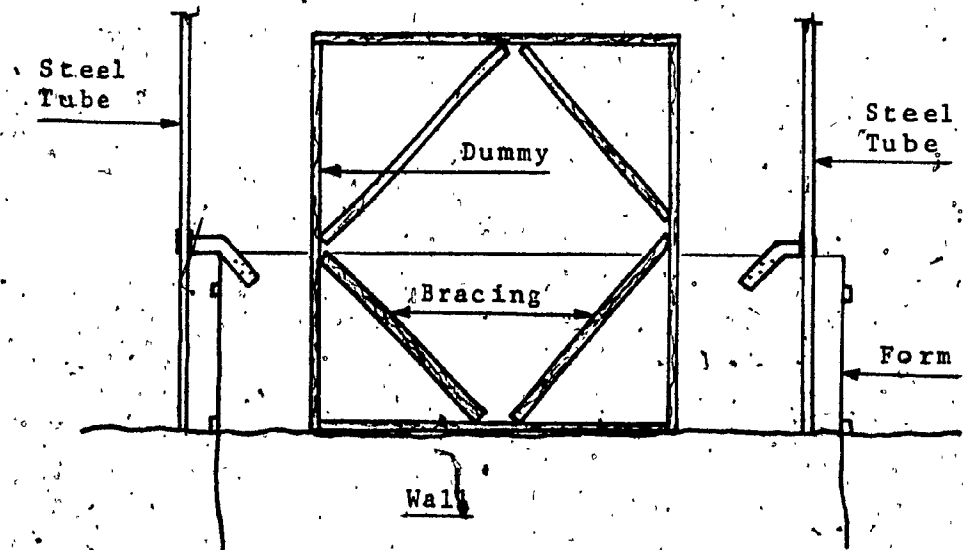

Fig. 3.60 - Location of a Window Dummy

The wood for the dummy can be of the cheapest type, even recycled boards. The frame can be utilized several times, if there are various windows or doors of the same size.

The structural problem of how to provide the window or door lintel is easily solved by adding some reinforcement

to the soil-cement. This reinforcement goes along the span and can be construction steel or bamboo. However, for cultural reasons and safety, users tend to prefer steel.

Three days after the block is cast, the dummy can be removed without problem. The frame is fixed in place without any problem.

To avoid the problem of precision related to the size and angles of the dummies, the self-helpers make them having the actual frame as the model, with no measurement involved.

The bracing does not offer additional problems.

Different fastening solutions exist to fix the frame on the wall, depending on the material used. Wooden frames are simply nailed on the soil-cement wall. Metal frames are fixed with anchors in drilled holes, which are then filled with a stronger soil-cement mixture.

Alternative solutions may be provided for those who do not have enough money to buy factory-made frames. It is not convenient to make windows or doors which are readily found in the market, as it requires expensive, tools and specialized labour. Instead, cheaper provisional



Fig. 3.61 - Door Dummies

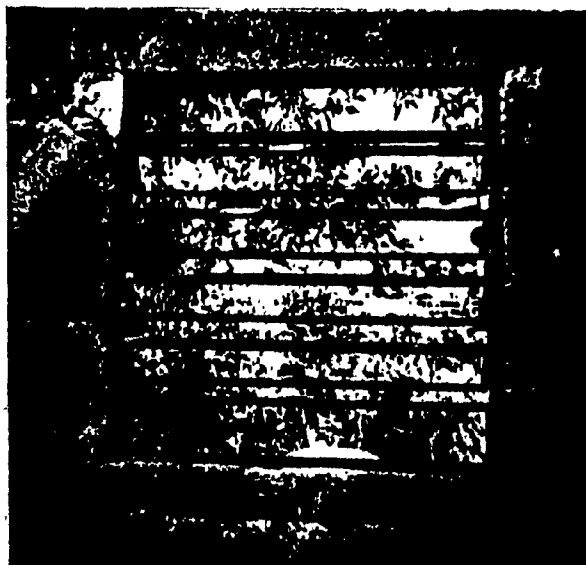

Fig. 3.62 - Window Frame Located

solutions may be adopted. For internal doors, an already very popular solution is the use of curtains. For windows, a possible solution would be to build two frames in such a way that the smaller would fit tightly in the larger one. The larger would be fixed to the wall, while the smaller would have a plastic cover. When light and ventilation are desired, the smaller frame is removed. When only

light is required, the smaller frame is used. Finally, when neither light nor ventilation is required, an internal curtain is closed.

There are two other problems: security and precision.

For security, an additional wooden panel may be added. The required precision could be obtained by providing standard window and door dummies together with the equipment, so that the self-helper could copy their dimensions.

In economic terms, probably the best solution would be the creation of a cooperative, which would be in charge of buying materials and prefabricated elements.

3.4.4.2 Field Experiment

The dummies for the openings were built according to the frames the owner already possessed, which were two steel windows 1.00 m x 0.90 m and a door 2.10 m x 0.80 m. The author did not help the owner to build them. The result, however, was quite satisfactory.

The owner decided to put the base of the window above the third block row, following the general pattern found in the favela.

The design phase is again divided into two parts. At first, it is necessary to establish where fixtures such as lamps, plugs, etc. will be placed. Since this decision does not influence anything except the user's comfort, he will choose where such fixtures are to exist. Technical problems such as sufficient well-distributed illumination in a room and the accessibility of switches are solved by the self-helper's experience and common sense. Furthermore, if some very unusual solution is proposed, there is always the possibility of the architect-advisor discussing it with the self-helper.

The layout of the fixtures is made on a copy of the architectural solution, using a code for each kind. Such code is presented below:

FIXTURE	CODE
Switch	#
Ceiling lamp	⊙
Lateral lamp	⊙
Plug	⊏

Fig. 3.66 - Code Used by the Self-Helper to Represent Electrical Fixtures

After the self-helper defines the positions of the various fixtures, there is a discussion of the proposal carried on with the architect-advisor. If no changes are required, the second part of the design phase starts.

This part does not have user participation. It is concerned only with the technical problems and must be solved by a specialized person. It might be questioned that the user carries out the design phase, but such discussion will be postponed until later.

The construction of the electrical system starts with the location of the conduits. This can easily be done by the user. The boxes for the switches and plugs are connected to plastic conduits. This set is tied to the iron tube that is closest to the position established by the owner. The plugs are tied just above the first row of blocks, while the switches are tied above the third row. This provides an equal height for all fixtures. The following figure illustrates the procedure.

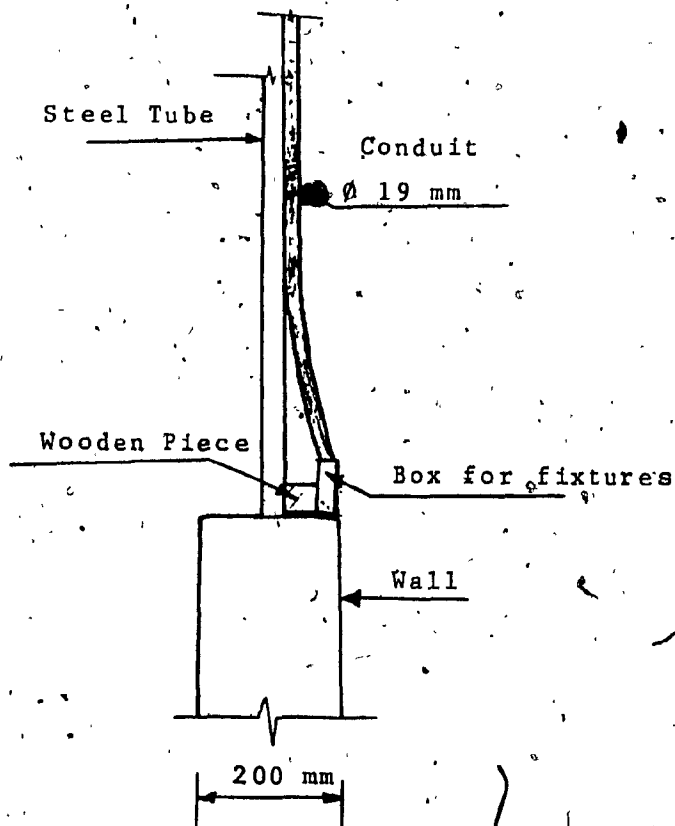

Fig. 3.67 - Location of an Electrical Box

As the next blocks are cast, the conduit is embedded.

When the walls are completely built, segments of the conduit remain exposed at the top. Using bends, the user brings all these conduits to a central box placed above the ceiling level. There are two alternatives: either there is a central box for each room, with all these boxes interconnected, or there is a central box for the entire house.

Both alternatives are shown in the figure below, using one of the architectural solutions presented previously.

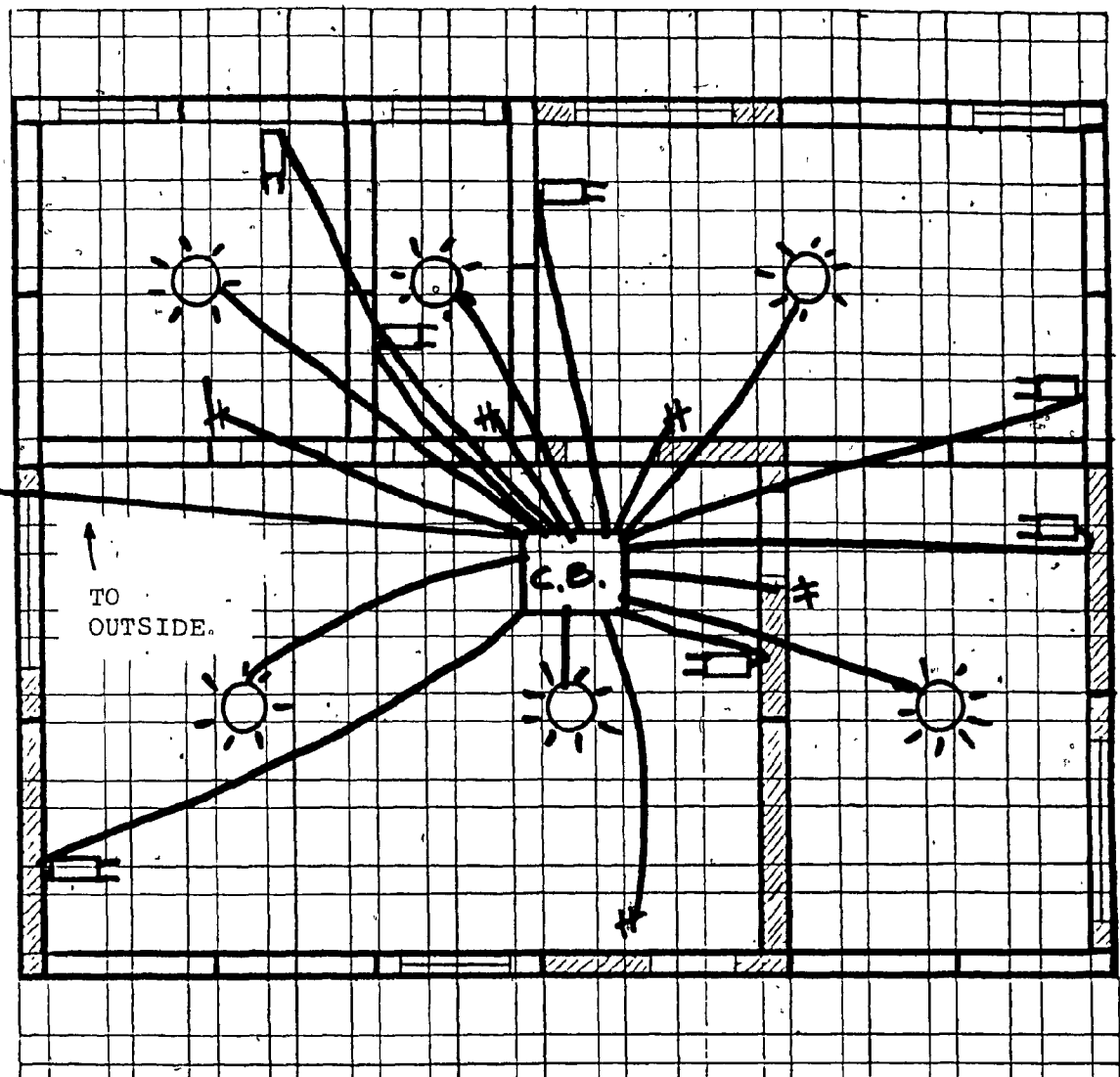

Fig. 3.68 - Electrical System Designed With a Central Box for the Whole House

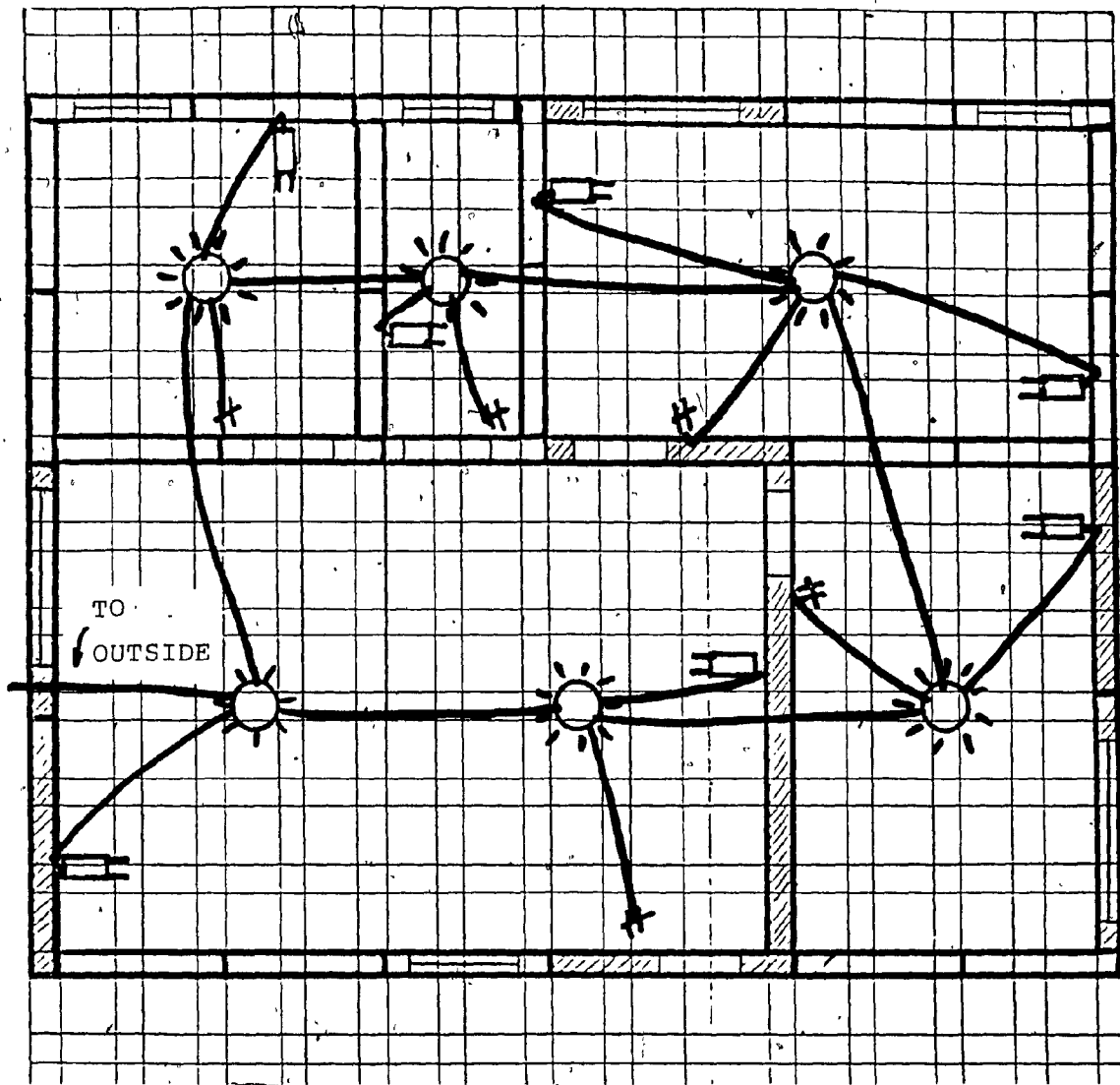

Fig. 3.69 - Electrical System Designed With a Central Box for Each Room

The total amount of conduits used in the first case (only one central box) comes to approximately 40 m, while in the second case it comes to approximately 30m. Of course, these figures are related to the specific solution presented. However, it seems logical to expect that using a central box

in each room will diminish the amount of conduits and wires used.

After bringing all the conduits of a room to a central point (the lamp fixture), and connecting the boxes of adjacent rooms, the self-helper has to install the wires.

The self-helper is required to insert a pair of wires in every conduit. These wires have to be 40 cm longer than the conduit, so that an excess of 20 cm appears at each end. To avoid complications, the self-helper uses only two wire diameters, one of each colour. The thinner one is used to connect the various fixtures to the central box. The thicker one is used to interconnect the various boxes.

Unless the user is an electrician, his job in the electrical system is finished. The next step is performed by a skilled labourer, who connects the wires, installs the fixtures and checks the circuits.

However, the majority of the work has been done by the self-helper, without any danger.

The conduits will be covered by a ceiling. An alternative using exposed wires should always be

avoided, since it is dangerous, mainly when there are children living in the house.

The problem of having specialized labour is practically unavoidable. The best that can be done is to select somebody in the settlement who is an electrician or an apprentice, and to charge him with making the final installation, as described above. In return, the beneficiaries of his service can pay him back by helping him to build his own house.

3.4.6.2 Field Experiment

The location of switches, lamps and plugs in the house was established by the owner on a copy of the house layout, provided by the author. Such solution is presented on the next page.

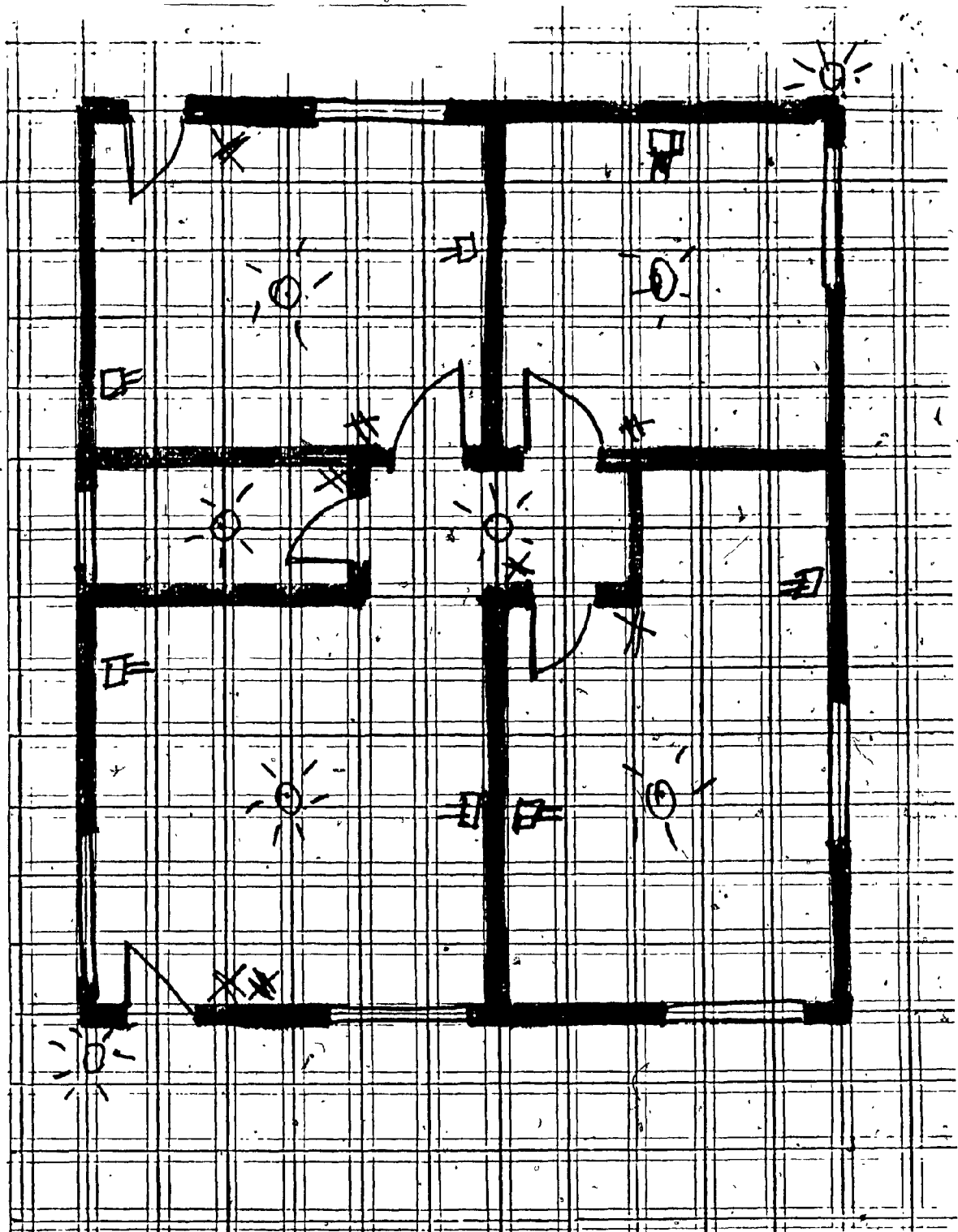

Fig. 3.70 - Solution for the Electrical System
Presented by the Self-Helper

The owner's solution followed the preceding code.

It seemed that the solution adopted is quite reasonable and did not need any modification.

During the construction process, the only step actually executed while the author was in Brazil was the placing of vertical conduits. First, conduits and boxes for the switches and plugs were bought. The conduits were cut in two parts and the boxes were fixed. The owner attached the conduits for plugs above the first course, and the conduits for switches above the third course. The system worked perfectly. After the following courses were cast, only the open side of the boxes could be seen.

The rest of the electrical system was not built in the presence of the author and will not be commented on.

The following pictures show a box inside a block and the top of the conduits above the walls. Such conduits should be cut later.



Fig. 3.71, 3.72 - Electrical System

3.4.7 Floor

3.4.7.1 Proposed System

The floor is built after the walls and roof structure have been built, so that it will not be damaged by traffic. The levelling of the floor is obtained directly from the top of the foundation blocks.

The first step consists of compacting the soil with the tamper described earlier, to provide a good base, so that the floor itself does not have to be very thick.

The soil base is compacted until it is approximately 10 cm below the level of the foundation blocks. The difference is checked by using the aluminium frame. Two or three segments can be added to cover the span. The frame is used in the smaller room dimension. The space between the soil base and the frame can be measured by using the four fingers of a hand as reference. The figure below illustrates the procedure.

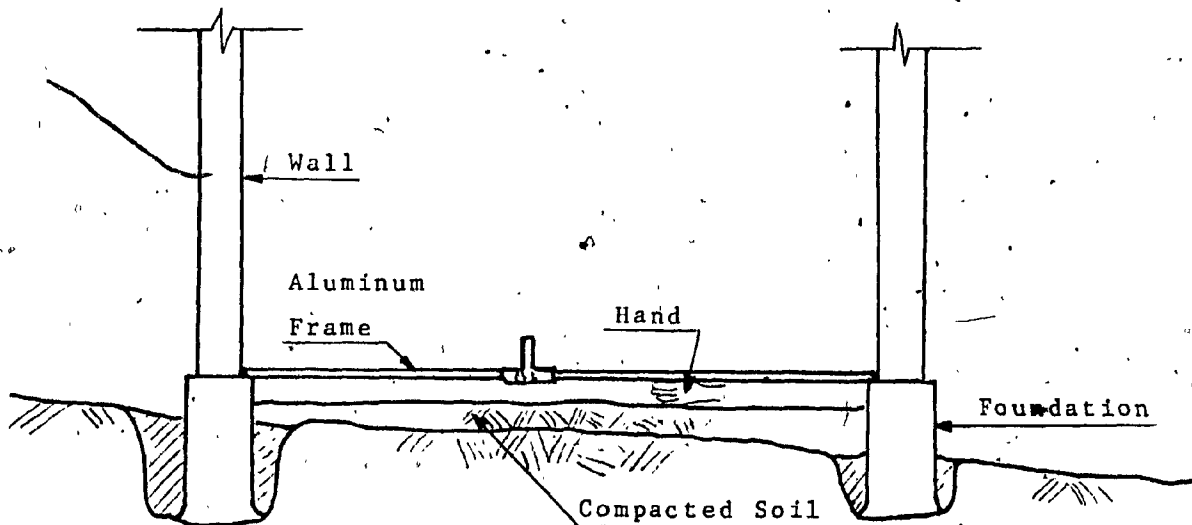

Fig. 3.73 - Procedure Used to Level the Floor

After the soil is compacted, the same soil-cement mixture used in the walls is prepared. The mixture is spread over the soil base and compacted. The compaction should start from the edges so an excess or shortage of material can be noticed. The compaction continues towards the center of the room, keeping the aluminium frame close for easier control.

The soil level should be checked constantly, so that hollows or bumps are readily found and corrected.

After the soil has been compacted, the finishing treatment consists of wetting the soil, spreading cement powder by hand on the surface and smoothing with a trowel. The smoothing process must start in the corner opposite the door.

The last step required some skill, but it can be easily learned, since the surface is already levelled. The result is a hard and smooth surface. Coloured floors can be obtained by adding a pigment. (4)

3.4.7.2 Field Experiment

The owner made the floor in two stages. At first, he compacted the soil inside the rooms, following the procedures described earlier. He developed very quickly the filling of the correct height between the top of the foundation and the compacted soil.

The second stage - a soil-cement floor - was not executed in both rooms, but only in part of one of them. The owner could not execute the floor while the construction was still in progress, since it could be damaged. However, the finished part presented a very good result. The owner compacted and smothered the floor very easily. The author also smoothed the floor and found it a very easy task.

3.4.8 Roof

3.4.8.1 Proposed System

The roof can be divided in two parts: structure and covering. The structure seems to be the most difficult to solve, since it has to be cheap, safe and of easy construction.

The slope and support for the roof is provided by a triangular wall built above the ceiling level. This wall is built using the same soil-cement mixture used in the walls.

A special wooden form is utilized to provide the inclination. It is fixed with bolts and is levelled by the wall which supports it. The following figure shows such a form:

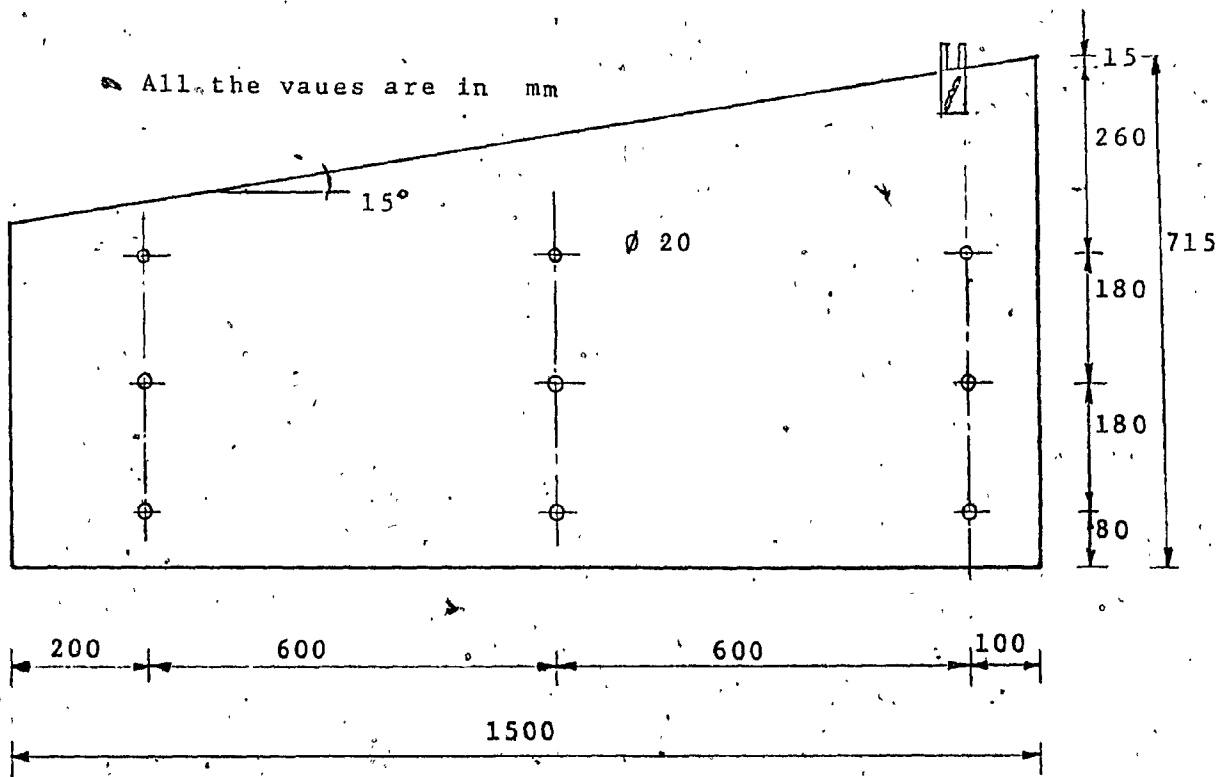

Fig. 3.74 - Gable Form

The procedure to use this form is explained below:

1. The forms are held together by a pair of bolts of the upper row, and are laid loosely on the wall.

2. The forms are brought to the corner and the bolts are tightened up. A piece of plastic tube 20 cm long is used between the forms to protect the bolt and to facilitate its removal.
3. A wooden lateral panel is fixed inside the form, to retain the soil-cement.

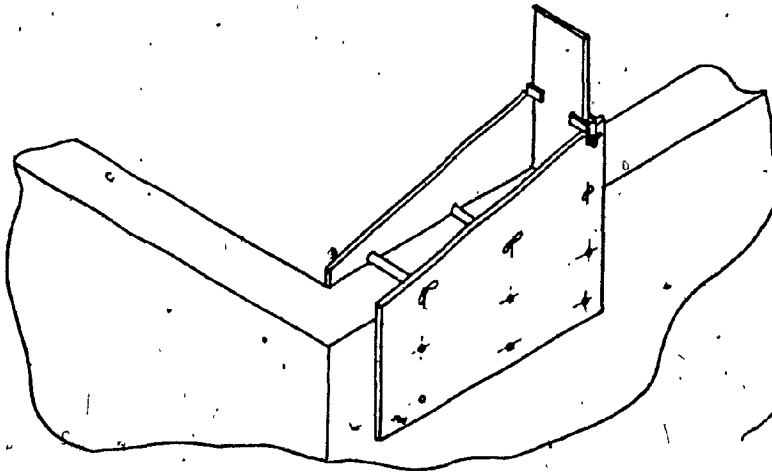

Fig. 3.75 - Form Mounted on the Wall

4. The pre-mixed soil cement is poured in the form and tamped.
5. The bolts are loosened and the form is removed.
6. The form is located on the opposite corner, and the same procedure takes place. This alternating

process has two advantages: it allows the soil-cement wall in one corner to dry for around 12 hours, which provides it with enough strength to avoid deformation when the form is used in that corner again; and it allows the self-helper to know how many times he has to use the form at each side of the triangular wall.

7. The form is brought to the initial corner and the same procedure takes place. To adjust the form and to maintain the modular dimension, it overlaps the previous wall up to the first bolts (20 cm). This procedure continues up to the triangle.

The drawings below show the procedures:

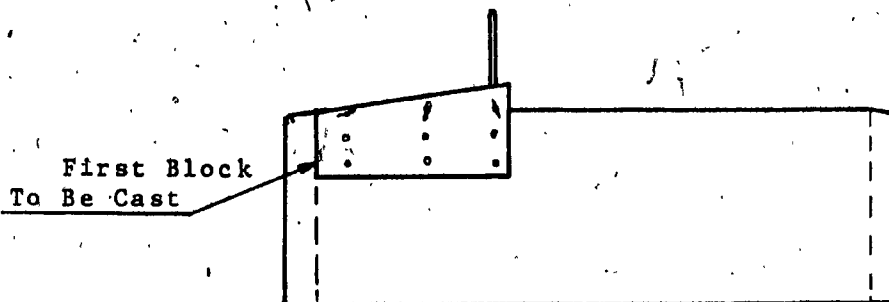

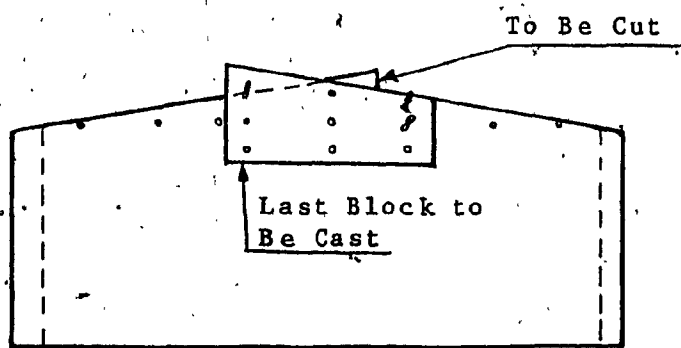
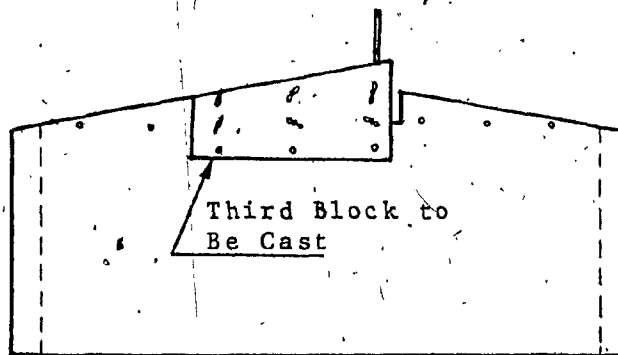
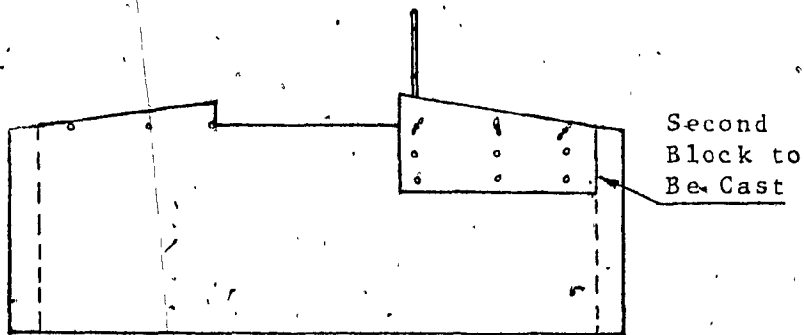

Fig. 3.76 Sequence to Build the Gable Wall

If a cross wall exists, the triangular wall is built up to this wall. Then the same forms used to build the common walls are used. To do so, new segments of steel tubes 55cm long are used. The wall has to be built until it reaches the height of the triangular wall.

The solution is exemplified below (the numbers express the order to use the forms):

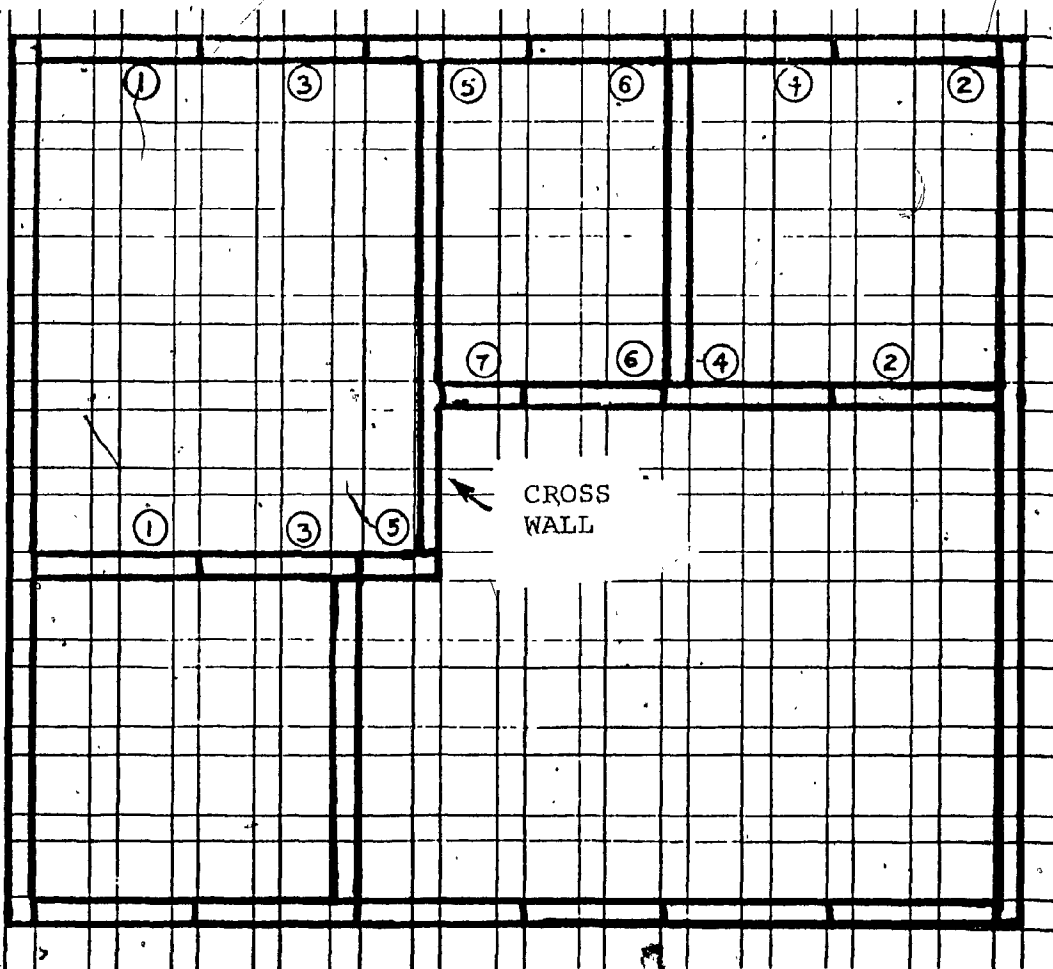

Fig. 3.77 - Roof With Cross Wall

When an orthogonal wall exists, it has to be cut close to the wall which is supporting the triangular form. This cutting is necessary to allow the triangular form to lay on the wall.

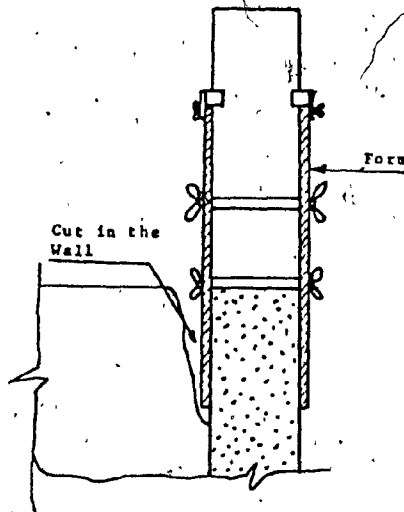

Fig. 3.78 - Solution for Orthogonal Wall

When all the triangular walls are built, a ridge pole is placed across the apexes, resting in circular holes made at the apex of the walls.

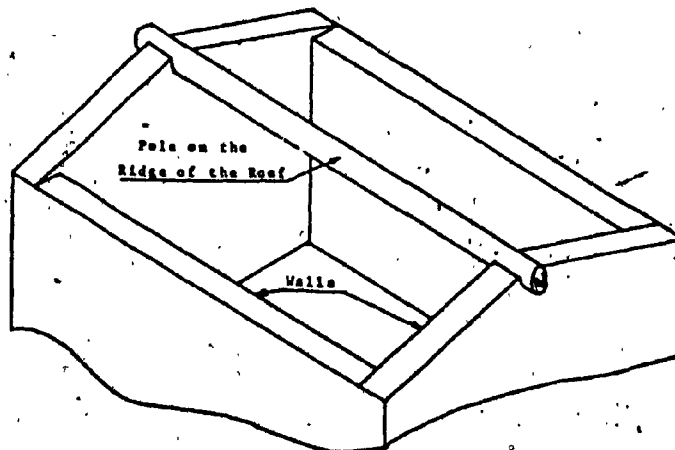

Fig. 3.79 - Ridge Pole Structure

To complete the roof structure, other poles are laid on the sides of the triangle walls, parallel to the ridge pole. The distance between poles depends on the covering that will be used (see following figure).

The poles are located using a special spacer, which provides the proper distance to instal the covering sheets.

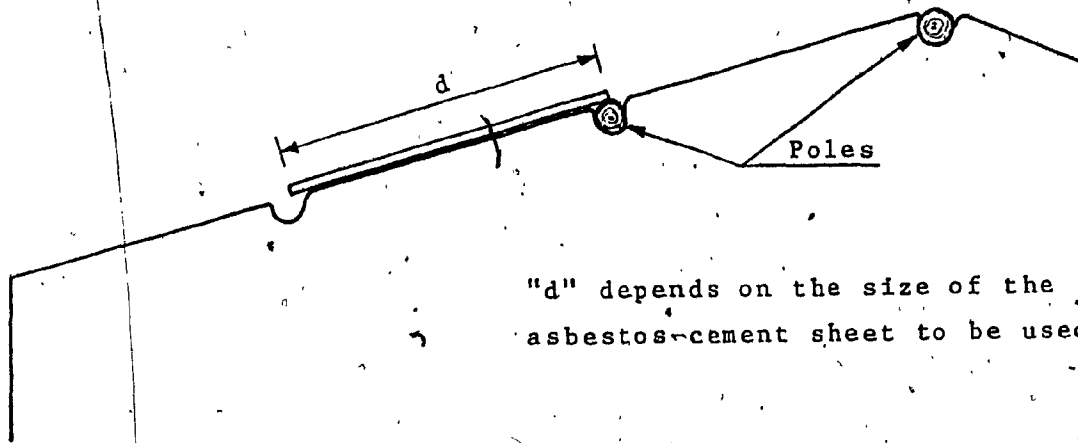

Fig. 3.80 - Location of Roof Poles

Two covering solutions are proposed: bamboo and asbestos-cement sheets.

Large diameter bamboo can be used by splitting in the middle and laying the halves as shown in the following figure.

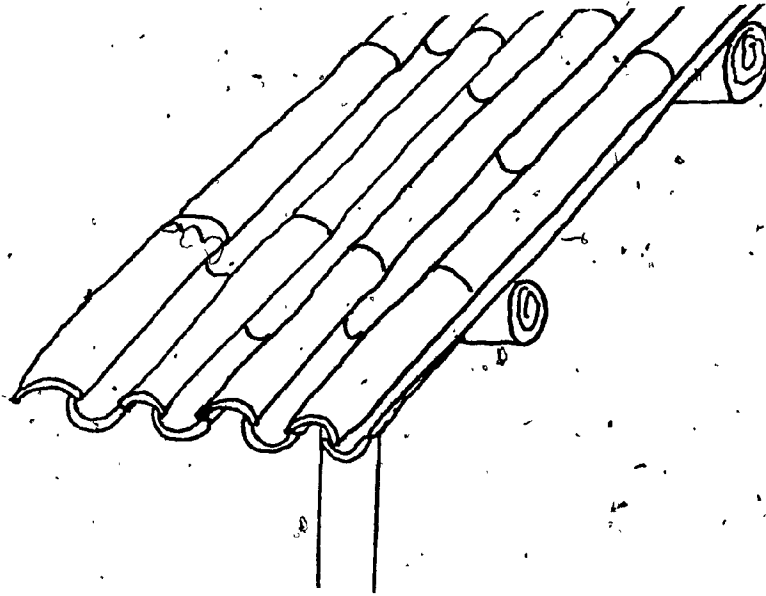

Fig. 3.81 - Bamboo Covering

However, the main problem of using bamboo is how to obtain it, since it is not readily available and a plantation would take around 2½ years to be cut.

When the covering adopted is asbestos-cement sheets, two main advantages arise:

- it is cheaper than any other well-accepted and reasonably tested covering in Brazil; and
- it is easy to install and maintain.

3.4.8.1.1 Conclusion

The sub-systems described above are the essential ones. Further improvements may be sought by the self-helper.

3.4.8.2 Field Experiment

The roof was not built while the author was in Brazil. However, a previous discussion with the owner about the system which should be applied showed a resistance to the use of poles. This resistance was probably related to the family's cultural background, since a roof using poles for structure is commonly related to very poor or rural housing.

The owner changed his mind when the economic advantages were shown to him.

3.4.9 Surface Treatment

The author proposed a cement-base paint for the external surface treatment, as well as in the bathroom and kitchen. The proposal was accepted.

3.4.10 Other Finishings

Other finishes such as ceiling, wooden or ceramic floors, were not proposed to the owner and could be provided by him later.

3.4.11 General Considerations

The author observed that the owner increased his care for the house as time passed. He became ever more concerned with the quality of the house and started to propose solutions and analyze the results.

It also seemed clear that he was able to absorb the new technologies, without needing a long learning process.

CHAPTER IV

CONCLUSION

CHAPTER IV

CONCLUSION

4.1 Analysis of the Proposed Technology

The validity of the technological solution is closely related to the results obtained in the field experiment. There, the success is measured by the capacity the self-helper has to understand and utilize the technology.

It seems that the potential of the technology can be evaluated in two aspects. First, since it is based on the five parameters proposed in Chapter II, it is necessary to consider the validity of such parameters. Secondly, it is necessary to see if the various sub-systems satisfied those parameters, and to what extent.

4.1.1 Evaluation of Parameters

4.1.1.1 Modular Coordination

The standardization and reduced number of equipment sizes provided by modular coordination was extremely valuable in economic terms. The great simplification in design and construction elements facilitated the self-helpers' learning process and increased their capacity to

explore the system's potential. It permitted a greater repetition of tasks and, as a consequence, a better control by the self-helper himself.

4.1.1.2 User's Participation

While developing their own architectural and electrical solutions, the users seemed to be able to give answers to their needs so completely, that it is quite valid to question if an architect, with a completely different background, would be able to understand and accept those needs. Another important consequence of a self-helper's design is the possibility of reducing the expensive participation of the architect, while still having a critical evaluation of the solution.

Self-help construction has its highest value in helping the poor to overcome economic constraints. This parameter could not be evaluated during the whole process due to the payment of the self-helper for a certain period. However, his ever increasing interest and involvement allows one to conclude that the self-helper tends to develop positive feelings of pride and satisfaction, as well as great care for his house, which appears as quality control on the construction phase, and better maintenance in the occupation phase.

4.1.1.3 Use of Low-Cost Materials

Since a large part of the labour is provided by the owner himself, materials are responsible for the majority of construction expenses. The use of low-cost materials seems to be essential if an affordable house for low-income people is intended. These materials may be new or may be traditional but used in a new way. Two problems related to their use arose during the experiment: the evaluation of their performance in use, and the user's cultural inertia, which generates resistance to the use of new materials. These problems deserve special attention, since they can create serious obstacles to the implementation of new technologies.

4.1.1.4 Man-Equipment Interaction

This new approach to the construction process, considering man and equipment characteristics as the basic determinants of the tasks they should perform and the way they interact, seemed to have an enormous influence on the self-helper's capacity to build his house.

In general terms, this approach helps to eliminate the need for skilled labour, always present in traditional technologies. It also tends to lead to higher productivity and more constant quality, which are hard to achieve with unskilled labour.

The approach also provides a new view to the problem of establishing the optimum level of industrialization. With man and equipment characteristics clearly set out, it is easy to determine at which level one should develop a technological solution.

4.1.1.5 Influence of Materials Characteristics

Since materials are to be transformed, their characteristics should be considered. This parameter cannot be seen so clearly as the others. However, it plays an important role in technological development, and, more specifically, equipment development.

4.1.2 Systems Compatibility with the Basic Parameters

For some sub-systems such as foundations, walls and roof, it was possible to take into consideration the various parameters discussed. For others, however, this was not completely possible. These sub-systems were plumbing and electrical sub-systems. For them, some improvements were made, so that the requirements for skilled labour and costly materials were substantially decreased. When this was not possible, one of the main reasons seems to be the way those systems have been developed and the elements found in the market to build them, as in the case of the electrical sub-system.

In an overall view, it seems that the main goal - to increase the potential of low-incomes to obtain their homes through the development of technologies that would allow a self-help attitude - was achieved.

Another important aspect refers to the self-helper's feelings towards the house and the construction process. The author's experience, in spite of its limitation, tends to suggest that strong feelings develop during such a process.

The owner's involvement can become a valuable and constant source of motivation, which slowly changes to pride and satisfaction during the process. However, if those expectations are frustrated, feelings of rejection and criticism can also build extremely quickly and with the same intensity.

4.2. Potential for New Research

The problem of housing low-income people is old and vast, yet there is need for much more information than is presently available in every single aspect of it. However, some points deserve special attention as there is little knowledge of them, and yet they seem to be very promising. These aspects are:

- user's participation in the design phase;
- search and evaluation of low-cost materials;
- man-equipment interaction;
- psychological behaviour of low-incomes during the self-help period;
- the process of learning new technologies.

The above-mentioned aspects bring the conclusion that the construction process cannot be viewed alone, but it is necessary to develop knowledge in complementary fields, mainly in a self-help process, since human factors play a central role.

With respect to the construction technology, some sub-systems need more research, so that building procedures can be simplified. One of these is the electrical sub-system.

The forms used to build the walls also need to be improved, to avoid problems related to finishes. It seems that a good way to solve the problem would be to assemble various segments 6M long to build an entire wall each time. Segments 4M long could also be used to solve the problem of corners.

The prototype built should be evaluated after construction for the following aspects: thermal comfort, water permeability of walls and roof, erosion of walls, and maintenance costs.

REFERENCES

REFERENCES

INTRODUCTION

1. Anon.: "USO DE NOVOS MATERIAIS NO BARATEAMENTO DA CONSTRUÇÃO", Dirigente Constructor, Vol. XV, No. 8, September 1979, pp. 39-44.
2. Dwyer, D.J.: "PEOPLE AND HOUSING IN THIRD WORLD CITIES - PERSPECTIVES ON THE PROBLEM OF SPONTANEOUS SETTLEMENTS", United Nations Department of Economic and Social Affairs, 1970.
3. Cew, Jr., J.M. de; Aydos, E.D.; Lucas, L.C.: "DEFICIT HABITACIONAL QUANTIFICAO DA NECESSIDADE HABITACIONAL NO R.G. SUL - 1970-1983", PUC, 1975.
4. Reinolds, C.W.; Carpenter, R.T.: "HOUSING FINANCE IN BRAZIL: TOWARDS A NEW DISTRIBUTION OF WEALTH", Urban Analysis in Latin America, 1975.
5. Anon.: "BRASIL S.A. - HABITAÇÃO", Edicoes J.B. No. 4, Jornal do Brasil.
6. Anon.: "PROPOSED MINIMUM STANDARDS FOR PERMANENT LOW-COST HOUSING", Ideas and Methods Exchange, No. 64, HUD, Washington, D.C., May 1966.
7. Kern, Ken: "THE OWNER-BUILT HOME", Charles Gaibner's Sons, New York, 1972.
8. Giberga, M.R.: "COMPARISON OF CONSTRUCTION COSTS IN LATIN AMERICAN COUNTRIES", HUD, Washington, D.C., December 1973.
9. Anon.: "COMMUNITY PROGRAMMES FOR LOW-INCOME POPULATIONS IN URBAN SETTLEMENTS OF DEVELOPING COUNTRIES", United Nations Department of Economic and Social Affairs, New York, September 1976.
10. Silva, R.R. da: "LA PARTICIPATION DE L'USAGER DANS LE PROCES DE CONSTRUCTION", Master's Thesis, Université de Montréal, 1980.

REFERENCES (cont'd)

11. Grindley, W.C.: "OWNER-BUILDERS: SURVIVORS WITH A FUTURE", Freedom to Build, Ed. John F.C. Turner & Robert Fichter, MacMillan, New York, 1972.
12. Bueneman, E.: "SPECIAL REPORT ON TECHNIQUES OF AIDED SELF-HELP HOUSING", HUD, Washington, D.C., 1973.
13. Allen, E.: "THE RESPONSIVE HOUSE", Introduction, MIT Press, 1974,
14. Anon.: "A PROPOSAL FOR A LOW-COST HOUSING PROGRAM", Puerto Rican Planning Board, Commonwealth of Puerto Rico, Santurce, Puerto Rico, probably 1958.
15. Abrams, C.: "MAN'S STRUGGLE FOR SHELTER IN AN URBANIZING WORLD", MIT Press, Cambridge, Massachusetts, 1964.
16. Anon.: "SELF-HELP HOUSING HANDBOOK", Rural Housing Alliance, Washington, D.C., February 1971, Vol. II.

CHAPTER II

1. Chameki, S.: "HOUSING SCIENCE, SCIENCE FICTION AND REALITY", Proc. 3rd International Symposium on Lower Cost Housing Problems, Concordia University, Montreal, May 1974.
2. Vernez-Monson, A.: "LES MARELLES: LESSONS IN DWELLING DESIGN", Industrialization Forum, Vol. 7, No. 1, 1976, pp. 47-56.
3. Habraken, N.J.: "SUPPORTS: AN ALTERNATIVE TO MASS HOUSING", Praeger Publishers, New York, 1972.
4. Andreade, J. I., Zamudio, J.: "PARTICIPATION IN MEXICO - THE CASE OF THE 'COLONIA GUERRERO'", Industrialization Forum, vol. 7 No. 1, 1976, pp. 33-40.
5. Pelli, R.: "SISTEMA UNNE-UNO", Universidade de São Paulo, Sao Paulo, 1978.

REFERENCES (cont'd)

6. Anon.: "NIVEL DE SATISFAÇÃO DOS MUTUARIOS EM PROGRAMAS DO SISTEMA BRASILEIRO DE HABITACAO", Instituto de Pesquisas Tecnologicas, Sao Paulo, 1976.
7. Anon.: "SOIL-CEMENT - ITS USE IN BUILDING", United Nations Department of Economic and Social Affairs, New York, 1964.
8. Anon.: "THE USE OF BAMBOO AND REEDS IN BUILDING CONSTRUCTION", United Nations Department of Economic and Social Affairs, New York, 1972.
9. Jayanetti, L.: "POLES FROM FOREST THINNINGS FOR LOW-COST HOUSING", Building Research and Practice, July/August 1978.
10. Anon.: "AUTOCONSTRUCCION - ESTUDIOS E INVESTIGACIONES APLICADAS", Secretaria de Assentamientos Humanos y Obras Publicas, Mexico City, 1980.
11. Anon.: "USO DE SOLO-CIMENTO NA HABITACAO", CEPED, Salvador, Bahia, 1980.
12. Kern, Ken: "THE OWNER-BUILT HOME", see Ref. 7 of Introduction.
13. Anon.: "SOIL MECHANICS FOR ROAD ENGINEERS", HM-50, Road, Road Research Laboratory, London, 1952, pp. 234.
14. Anon.: "BOLETIM DE INFORMACOES No. 54", Associacao Brasileira de Cimento Portland, 1948.
15. Masani, N.J.: "BAMBOO CONCRETE COMPOSITE CONSTRUCTION FOR LOWER COST HOUSING", Proc. 3rd International Symposium on Lower Cost Housing Problems, Concordia University, Montreal, May 1974.
16. Anon.: "TRENDS IN THE INDUSTRIALIZATION OF BUILDING", United Nations, New York, 1970.
17. Anon.: "GUIDELINES FOR GOVERNMENT POLICIES AND MEASURES FOR GRADUAL INDUSTRIALIZATION OF BUILDING", United Nations, New York, 1974.

REFERENCES (cont'd)

18. Franssens, M.: "TYPIFICATION - THE BRIDGE BETWEEN ARCHITECTURE AND INDUSTRIALIZED BUILDING", Industrialization Forum, Vol. 5, 1979, pp. 21-24,
19. Banz, G.: "OPPRESSIVE AND NON-OPPRESSIVE MODULARITY IN PREFABRICATED HOUSING", ISHOP, Concordia University, Montreal, 1974.
20. Anon.: "CÓDIGO MUNICIPAL DE OBRAS", Prefeitura Municipal de Porto Alêgre, Porto Alegre, 1973.
21. Jones, J.C.: "DESIGN METHODS - SEEDS OF HUMAN FUTURES", John Wiley & Sons Ltd., 1970, pp. 123-133.
22. Singleton, W.T.: "THE SYSTEMS PROTOTYPE AND HIS DESIGN PROBLEMS", Ergonomics, Vol. 10, No. 2, 1967.
23. Turner, I.D.: "TECHNOLOGY AND AUTONOMY", Freedom to Build, Ed. John Turner & Robert Fichter, The MacMillan Company, New York, 1972, pp. 199-237.
24. Dalix, P.: "THE DEVELOPMENT OF AN APPROPRIATE TECHNOLOGY IN THE THIRD WORLD - THE EXPERIENCE OF TUNISIA", Industrialization Forum, Vol. 6, No. 2, 1975, pp. 27-34.
25. Rybczynski, W.; Ortega, A.; Ali, W.: "SULPHUR CONCRETE VERY LOW COST HOUSING", Minimum Cost Housing Group, School of Architecture, McGill University, Montreal, 1974.

CHAPTER III

1. Davidson, C.H.: "IMPORTANCE OF CONVENTIONS IN THE INDUSTRIALIZATION OF BUILDINGS", Paper presented to Sistematizacion E Industrializacion de la Vivienda Seminar, Mexico, November 10, 1974.
2. Kern, Ken: "THE OWNER-BUILT HOME", see Ref. 7 of Introduction.

REFERENCES (cont'd)

3. Anon.: "SOIL-CEMENT - ITS USE IN BUILDING", see Ref. 7 of Chapter II
4. Rybczynski, W., et al: "STOP THE FIVE GALLON FLUSH, SAM", Minimum Cost Housing Group, School of Architecture, McGill University, Montreal, 1976.
5. Anon.: "SOIL-CEMENT - ITS USE IN BUILDING", see Ref. 7 of Chapter II.

APPENDIX

APPENDIX

DETERMINATION OF THE SOIL-CEMENT MIXTURE:
LABORATORY TESTS AND RESULTS

The exact quantities of soil and cement that should be added were determined in three steps: selection of soil; laboratory tests; and determination of containers' dimensions. The aim was to obtain the least expensive mixture (implying the minimum amount of cement), which could satisfy loading requirements for walls.

Selection of Soil

The soil found on the site was tested and the results showed that an excessive percentage of organic matter inhibited the bonding action of cement. The soil also had a high percentage (50-60%, according to the depth) of montmorillonite clay. When test specimens were left submerged for 24 hours, they fell apart due to the expansivity of the clay and the absence of cement bonding.

To neutralize the effect the organic matter had on cement, 4% lime was added. The results, however, were scarcely better. The test specimens survived the 24 hrs submersion, but their compressive strength varied from

0.4 MPa to 1.2 MPa, for a cement percentage varying from 11 to 12%. Furthermore, there was a large variation of results obtained with the same percentage of cement.

Based on such results, the author decided to utilize a more suitable soil. It seemed economically reasonable to do so, since the cost of the soil, including material and transportation, was around Cr\$150.00/m³ (C\$2.50/m³), while the cement cost Cr\$300.00/sack (C\$5.00/sack) of 50 kg. Thus, the increase of 1% in cement would cost Cr\$120.00 (C\$2.00)/m³. Since the reduction of cement percentage using the better soil would be not less than 10%, this would imply a reduction of cost of about Cr\$1,050.00 (C\$17.50)/m³.

An excellent soil was found 5 km from the site. A simple field test (described in Chapter II) showed that the soil had a large percentage of sand.

Laboratory Tests

At first, the granulometric curve of the soil was determined. The results obtained were:

Passing No. 4 Sieve : 93%
Passing No. 40 Sieve : 46%
Passing No. 200 Sieve: 22%

There was no trace of organic matter since the soil was extracted from 2-5 m depth.

The optimum water content was also determined. The soil was compacted according to ABNT (Brazilian Technical Norms Association). The compaction was made as follows: the soil was compacted in a brass cylinder 100 x 50 ϕ mm in three layers, with a 4 kg piston, falling from 500 mm height.

Water contents were 14, 16, 18, 20 and 24%. The maximum density was obtained with an 18% water content, and was 2.24 g/cm³.

This water content was used for the soil-cement mixtures. Test specimens utilizing 6, 8 and 10% of cement were compacted in the same way described above. The results of these tests are presented below:

Percentage of cement		Average of 2 specimens
weight	volume	
6	7.2	2.8 MPa
8	9.6	3.3 MPa
10	12.0	3.6 MPa

The required resistance was 2.0 MPa, so that the 6% cement mixture was adopted. Lower percentages were avoided