

INFORMATION TO USERS

This manuscript has been reproduced from the microfilm master. UMI films the text directly from the original or copy submitted. Thus, some thesis and dissertation copies are in typewriter face, while others may be from any type of computer printer.

The quality of this reproduction is dependent upon the quality of the copy submitted. Broken or indistinct print, colored or poor quality illustrations and photographs, print bleedthrough, substandard margins, and improper alignment can adversely affect reproduction.

In the unlikely event that the author did not send UMI a complete manuscript and there are missing pages, these will be noted. Also, if unauthorized copyright material had to be removed, a note will indicate the deletion.

Oversize materials (e.g., maps, drawings, charts) are reproduced by sectioning the original, beginning at the upper left-hand corner and continuing from left to right in equal sections with small overlaps.

Photographs included in the original manuscript have been reproduced xerographically in this copy. Higher quality 6" x 9" black and white photographic prints are available for any photographs or illustrations appearing in this copy for an additional charge. Contact UMI directly to order.

**ProQuest Information and Learning
300 North Zeeb Road, Ann Arbor, MI 48106-1346 USA
800-521-0600**

UMI[®]

**CPDICENTER: WEB-BASED VIRTUAL
CONSTRUCTION PROJECT DOCUMENT
INFORMATION CENTER IN SUPPORT OF
CLAIMS PREPARATION**

MAMOON MOHAMMAD HAMMAD

A Thesis
In
Building, Civil and Environmental Engineering
Faculty of Engineering and Computer Science

Presented in Partial Fulfillment of the Requirements
for the Degree of
Ph.D. in Engineering (Building)
at Concordia University
Montreal, Quebec, Canada

© Mamoon Mohammad Hammad, 2001



**National Library
of Canada**

**Acquisitions and
Bibliographic Services**

**395 Wellington Street
Ottawa ON K1A 0N4
Canada**

**Bibliothèque nationale
du Canada**

**Acquisitions et
services bibliographiques**

**395, rue Wellington
Ottawa ON K1A 0N4
Canada**

Your file Votre référence

Our file Notre référence

The author has granted a non-exclusive licence allowing the National Library of Canada to reproduce, loan, distribute or sell copies of this thesis in microform, paper or electronic formats.

The author retains ownership of the copyright in this thesis. Neither the thesis nor substantial extracts from it may be printed or otherwise reproduced without the author's permission.

L'auteur a accordé une licence non exclusive permettant à la Bibliothèque nationale du Canada de reproduire, prêter, distribuer ou vendre des copies de cette thèse sous la forme de microfiche/film, de reproduction sur papier ou sur format électronique.

L'auteur conserve la propriété du droit d'auteur qui protège cette thèse. Ni la thèse ni des extraits substantiels de celle-ci ne doivent être imprimés ou autrement reproduits sans son autorisation.

0-612-63988-6

Canada

ABSTRACT

“CPDICenter: Web-Based Virtual Construction Project Document Information Center In Support Of Claims Preparation”

Mamoon Mohammad Hammad, PhD in Building, Civil & Environmental Engineering
Concordia University, 2001

Construction projects' information, in the most part, is document-based. This information documents progress and performance, also supports daily activities. The industry has not paid enough attention to establishing a framework for capturing and storing project's document-based information, which is necessary for substantiating claims' facts. Eventually high “post-construction” dispute resolution costs became the norm, especially in complex construction projects. Understanding the history of such undertakings—without documents—is an enormous one, because to understand the actual history of a project, all-relevant documents have to be available. The outcome and resolution of construction performance-related disputes rely, almost exclusively, on relevant contemporaneous documents from the periods concerned. However, documents sprawling to various project locations without discernable directory structures complicate maintenance functions for backing up and archiving files. Construction projects are temporary organizations that rely heavily on contemporaneous documents to exchange and disseminate information, and to prove claims' causes and damages. Hence, difficulties in locating and accessing critical documents have to be minimized. Registering and cross-referencing every document that is issued by any group in the project achieves that. Currently, the industry is not unanimous on how to solve this problem and with slimming contractor profits (due to severe competition and increased

modern projects' complexity) the construction industry has not invested sufficiently to develop data schemas to represent project documents' contents, or context. Modeling such information is necessary for mapping the knowledge contents into databases. This research identified the aforementioned discords and proposes a Web-Based solution; entitled the Construction Project Document Information Center (CPDICenter). The CPDICenter is a web-based system with communication architecture to tackle technical constraints like geographical dispersion of operations, multiplicity of project groups, and document workflows. It also allows groups to register, store, access, and search online for any documents in the project via a web browser. The CPDICenter is a project-wide document control system to capture documents from all project groups/participants. This research presents the CPDICenter's web-based workflow system for digital document capture, classification, indexing, and storage, in order to expedite finding and retrieving documents for claim preparation processes. The CPDICenter works with any project organization encompassing any number of groups. The payback will be reduced times for retrieving documents, reduced costs of printing and scanning, and consequently claims' preparation costs. This system intends to capture—in concert with contemporaneous documents—other information about project events' context, documentation rationale and process data. Accurate accounts of project events are essential for a successful and equitable claim analysis and resolution. Such information is a requisite for reconstructing any project's history and finding the causes of disruptions and/or changes to any construction program baselines especially when the people who worked in the project have left to other jobs or their memories have faded.

ACKNOWLEDGEMENTS

I thank Allah the most Gracious and Most Merciful for the beginning, the guidance, and the sustenance. I thank my family for their patience, care, and unconditional support.

Thanks are due to my research supervisor Dr. Sabah Alkass for his guidance, open mindedness, willingness to explore many venues, and for his encouragement. I thank also Prof. Osama Moselhi for his patronage, and moral support. Many thanks go to the proposal examining committee Professor Radu Zmeureanu, Dr. Demerilli and Dr. Chen for their comments, and favorable interest in my research work. I wish to thank also Dr. Fariborz Haghighat for chairing my comprehensive and proposal committee. I am also thankful to the external examiner, Dr. George Jergeas, for his comments and interest in the research subject.

The author acknowledges the financial support of the '*Fonds pour la Formation de Chercheurs et l'Aide a la Recherche*' (FCAR)-Quebec, for the years 97/98 & 98/99. I am sincerely thankful for their recognition of the importance of my work and their support.

The author acknowledges as well, the financial support of the *School of Graduate Studies for Concordia University External Grant Holder Doctoral Scholarship* for 1997, 98, & part of 99, and for the *School of Graduates Teaching Fellowship Award* for 2000/2001. Thanks are due to Dr. Sabah Alkass for partial financial support from his NSERC research grant.

I am also thankful to the experts who answered my questionnaires, with special thanks to "Revay & Associates", and "Tardiff & Murray Consultants" for meeting with me on various occasions and for answering my questions, and giving me insightful opinions.

TABLE OF CONTENTS

<i>LIST OF FIGURES</i>	<i>XII</i>
<i>LIST OF TABLES</i>	<i>XV</i>
<i>ACRONYMS</i>	<i>XVI</i>
<i>PREFACE</i>	<i>XVII</i>
CHAPTER ONE: INTRODUCTION TO THE PROBLEM OF DOCUMENTATION AND SUPPORT FOR CLAIMS ANALYSIS	1-1
1.1 – Background and Problem Domain	1-1
1.2 – Affected Project Groups	1-2
1.3 – The Documentation Problems in Construction	1-3
1.3.1 – Claims Preparation and Document Management Problems	1-5
1.4 – Scope Of Research	1-8
1.5 – Research Motivation	1-10
1.5.1 – The Need for a Solution to the Documentation System Problems.....	1-11
1.5.2 – Results of Experts’ Questionnaire on the Issue of Supporting Documentation for Claims	1-13
1.5.3 – Current Challenges Facing Documentation for Claims	1-16
1.5.4 – Diagnosing Construction Documentation Systems Problems	1-17
1.6 – Types and Nature of Construction Documents	1-19
1.7 – Handling of Claims’ Documents by Claims Analysts	1-22
1.7.1 – Claims Preparation Process and Document Classification	1-23
1.7.2 – Expert-Generated Documents: Organisation and Inference	1-25
1.7.3 – Comments about Document Handling during Analysis of Claims	1-26
1.8 – Research Objectives	1-27
1.9 – Thesis Methodology for Solution Development	1-28
1.9.1 – Modeling Document Roles in Construction Management.....	1-30
1.10 – Thesis Organization	1-31

**CHAPTER TWO: CLAIMS, DOCUMENTATION, AND DOCUMENT MANAGEMENT:
A LITERATURE REVIEW..... 2-1**

2.1 – Introduction 2-1

2.2 – Ontology of Construction Claims..... 2-2

2.2.1 – Causation Studies 2-2

2.2.2 – Claims Analyses 2-3

2.2.3 – Claims Management..... 2-6

2.3 – Change Management..... 2-8

2.4 – Review of IT Applications for Claims..... 2-10

2.5 – Claims Modus Operandi and the Burden of Proof..... 2-13

2.6 – Review of Document Management Solutions for the Construction Industry..... 2-15

2.7 – Document Associations with Project Information 2-19

2.8 – Review of Web-based Collaboration Research 2-20

2.9 – Benefits of a Web-based Project Document Center..... 2-21

2.9.1 – Review of Web-Based Project Document Management Systems 2-22

2.10 – Review of available Commercial Document Control Tools 2-25

2.11 – Documentation Problems: Recap of the State of the Art. 2-27

**CHAPTER THREE: ANALYSIS AND MODELING OF CONSTRUCTION
PROJECT DOCUMENT INFORMATION3-1**

3.1 – Introduction 3-1

3.2 – Examples of Claims Documentation 3-2

3.2.1 – Anecdote 1: Owner is the Construction Manager and Engineer..... 3-3

3.2.2 – Anecdote 2: Consultant is the CM in a multi-stage project 3-3

3.2.3 – Anecdote 3: Changed Conditions in a Stipulated-Price Contract. 3-3

3.2.4 – Anecdote 4: Owner Responsible for Design Information..... 3-4

3.2.5 – Anecdote 5: Owner Disrupts Work Through a Faulty Change Order 3-5

3.3 – Formalising Documentation Through Business Rules	3-6
3.3.1 – Sources of Claims’ Business Rules	3-8
3.3.2 – Business Rules Examples for Claims Documentation.....	3-9
3.4 – Recreating Document Trails: Sequence Diagrams	3-10
3.4.1 – Example: Reconstructing documentation for a Piping Problem.....	3-12
3.5 – Modeling Claim Documentation Rules.....	3-13
3.6 – The Process of Case or Issue Documentation.....	3-15
3.6.1 – Claims-Related Business Processes.....	3-16
3.6.2 – Data and Information content in Construction Documents	3-17
3.7 – Document Information from Claims Analysis	3-19
3.7.1 – Phase 1: Analyze and identify issues.....	3-20
3.7.2 – Phase 2: Analyze all schedules and changes	3-20
3.7.3 – Phase 3: Analyze Project Cost Records.....	3-21
3.7.4 – Phase 4: Develop damages	3-21
3.7.5 – Phase 5: Prepare Claim Report.....	3-21
3.8 – Discovery Procedure.....	3-22
3.9 – Project Management Process Information.....	3-25
3.9.1 – Understanding Detailed Document Flows: An Example.....	3-27
3.9.2 – Incorporating the CPDICenter with the Project Enterprise	3-28
3.10 – Data Models	3-31
3.11 – Users’ Search Criteria.....	3-32
3.11.1 – Search and Retrieval.....	3-33
3.12 – Legal Considerations.....	3-34

**CHAPTER FOUR: PROPOSED MODEL: CPDICENTER INFORMATION
SYSTEM ARCHITECTURE** **4-1**

4.1 – Introduction	4-1
4.1.1 – Technology Infrastructure	4-2

4.2 – Building a Solution	4-3
4.3 – Project Structure and Communications	4-7
4.3.1 – Influence of Project Management Technique on Document Control	4-8
4.4 – Document Control for Distributed Project Groups.....	4-9
4.4.1 – Physical Communications Network Needs.....	4-10
4.5 – The Document Information Center	4-13
4.5.1 – CPDIDCenter Structure.....	4-13
4.5.2 – Adapting the CPDIDCenter Various Project Organizations.....	4-16
4.5.3 – Features Of This New Framework	4-19
4.6 – CPDIDCenter website services & Components	4-20
4.7 – The Web Technology.....	4-22
4.8 – CPDIDCenter Information Architecture and Workflow.....	4-24
4.8.1 – Highlights of the CPDIDCenter System Architecture	4-24
4.8.2 – CPDIDCenter Workflow Highlight.....	4-26
4.9 – CPDIDCenter Document Classes and Web Folders.....	4-29
4.9.1 – Document Storage Requirements	4-29
4.9.2 – Document classes	4-30
4.9.3 – Document Webfolders Design.....	4-33
4.10 – Standardizing The CPDIDCenter Development.....	4-35

CHAPTER FIVE: IMPLEMENTATION OF THE CPDIDCENTER WEB

DOCUMENT META INFORMATION DATABASE	5-1
5.1 – Purpose and Mission of the DMID.....	5-1
5.1.1 – CPDIDCenter DMID Benefits.....	5-2
5.2 – What is a Web Database?	5-3
5.2.1 – The Location of the DMID.....	5-3
5.2.2 – Replication.....	5-3
5.3 – Development Environment and Technology Preview.....	5-5

5.3.1 – The Web-Database Interaction Technology	5-6
5.4 – Scripting and Client-Server Communication.....	5-7
5.5 – Connecting to DMID Web Database.....	5-9
5.5.1 – Linking to the ADO Library	5-9
5.5.2 – Providing Data Services	5-10
5.5.3 – Adding Records to the Database.....	5-10
5.6 – Claims Information Classification and DMID Design	5-12
5.7 – Functional Modeling and DMID Design.....	5-14
5.8 – Case-Based Document Categorization Examples	5-16
5.8.1 – Labour Damage Document Profiling Example.....	5-16
5.8.2 – Delay Claim Document Profiling Example.....	5-18
5.8.3 – Changes, and Extra Work Document Profiling Example	5-19
5.9 – Classification of Claims Information	5-20
5.9.1 – Claim Categories	5-21
5.9.2 – Types of Damages	5-24
5.10 – DMID Conceptual and Design Schemas.....	5-27
5.10.1 – DMID Relational Database Schema.....	5-28
5.10.2 – Project Process Control Information Components	5-30
5.10.3 – Contract Requirements and Workpackages	5-30
5.10.4 – Document Versioning, Workflow and Virtual Webfolders	5-31
5.11 – CPDIDCenter DMID Validation and Hypothetical Case Project.....	5-35
5.12 – Standardizing the DMID development.....	5-39
 CHAPTER SIX: IMPLEMENTATION AND VALIDATION OF THE CPDIDCENTER SERVICES.....	 6-1
6.1 – CPDIDCenter Management	6-1
6.1.1 – Central VS distributed management.....	6-2
6.2 – CPDIDCenter Access and Document Flow Amongst Groups	6-3

6.2.1 – Mapping the Flow for Claim Documentation.....	6-5
6.3 – Software Tools and Technology Used in Development	6-7
6.4 – CPDIDCenter Website: Implementation and User Interface.....	6-10
6.5 – Validation Of the System Using a Sample Case Project.....	6-12
6.6 – CPDIDCenter Search and Retrieval Services.....	6-14
6.6.1 – Document Submissions and Registration in the CPDIDCenter.....	6-17
6.7 – Search and Retrieval of Documents and Information.....	6-23
6.7.1 – Document Search Examples.....	6-23
6.7.2 – Claim Files search Examples.....	6-28
6.7.3 – Information Used to Classify Claim Files and Documents.....	6-32
6.7.4 – CPDIDCenter Project Information Search Pages	6-33
6.8 – Prototype Validation comments	6-38

CHAPTER SEVEN: CONCLUSIONS AND RECOMMENDATIONS FOR FUTURE WORK..... 7-1

7.1 – Conclusions	7-1
7.1.1 – Construction Documentation.....	7-3
7.1.2 – Constraints Facing Project Document Control	7-4
7.1.3 – CPDIDCenter Paradigm: Benefits & Advantages.....	7-5
7.2 – Contributions: CPDIDCenter Paradigm.....	7-7
7.3 – Work Limitations	Error! Bookmark not defined.
7.4 – Recommendations for Future Research	7-10

CHAPTER EIGHT: REFERENCES 8-1

APPENDIX A: CPDIDCENTER DOCUMENT TYPES, CLASSES AND SAMPLE CONTRACT CLAUSES A-1

A.1 – Common Titles of Pre-Construction Documents:	A-1
A.2 – Document Titles for the Construction Operation	A-2
A.3 – CPDIDCenter Document Classes	A-3
A.3.1 – Class: Proprietary	A-3
A.3.2 – Class: Public	A-4
A.3.3 – Class: Transactions	A-5
A.3.4 – Class: Definitions	A-7
A.4 – Sample Contract Specification Sections and Clauses	A-8
A.5 – Sample Contract Agreement Clauses	Error! Bookmark not defined.
A.5.1 – Parties Intentions	A-10
A.5.2 – Possession and Completions.....	A-10
A.5.3 – Control of construction operations	A-10
A.5.4 – Payments.....	A-11
A.5.5 – Statutory Obligations	A-11
A.5.6 – Injuries, Damages, and insurance	A-11
A.6 – Sample Contract Requirements Procedure Statements	A-12
A.6.1 – Sample procedure Statement for Request for Quote or Proposal.....	A-12
A.6.2 – Sample Procedure Statement for Work Status.....	A-14
A.6.3 – Sample Procedure Statement for a Meeting Agenda	A-15
APPENDIX B: UML, DFD & ER MODELING LANGUAGES NOTATIONS	B-1
B.1 – Unified Modeling Language UML Notation Guide	B-1
B.2 – Data Flow Diagram (Functional Modelling Notation Guide)	B-4
B.3 – Entity Relational Data Modelling Notation	B-5
B.4 – Summary of ER (Entity-Relational) Diagram Notation	B-7
APPENDIX C: SAMPLE EXPERT SURVEY QUESTIONNAIRE	C-1
C.1 – Introductory Letters Sent to Experts	C-1

C.2 – Survey Meeting Agenda With Expert to Answer the Questionnaire C-2

C.3 – Questions included in every Interview Questionnaire..... C-3

C.4 – Survey of User Specifications for future Web-Based Document Search and Retrieval Portal C-4

List of Figures

FIGURE-1.1: SLIMMING CONTRACTORS PROFITS IN THE LAST TWO DECADES	1-5
FIGURE-1.2: BUILD-UP OF CONSTRUCTION DOCUMENTS DURING A PROJECT'S LIFE	1-20
FIGURE-1.3: VARIOUS FUNCTIONAL ROLES DOCUMENTS HAVE IN THE CONSTRUCTION PROCESS	1-31
FIGURE-2.1: EDMS MARKET SHARES BY FUNCTIONALITY IN THE US FOR 1998. SOURCE: KMWORLD FEBRUARY 1999	2-25
FIGURE-3.1: EXAMPLE DOCUMENT FLOWS AMONGST PROJECT MANAGEMENT FUNCTIONS.....	3-7
FIGURE-3.2: SEQUENCE DIAGRAM SHOWING DOCUMENTS GENERATED FOR A PIPING PROBLEM	3-11
FIGURE-3.3: MODEL OF CLAIMS BUSINESS RULES THAT INFLUENCE DOCUMENTATION.....	3-14
FIGURE-3.4: INFORMATION SUBJECTS USUALLY INCLUDED IN A CONSTRUCTION DOCUMENT.....	3-18
FIGURE-3.5: MAIN PHASES IN A CONSTRUCTION PERFORMANCE IMPACT CLAIM ANALYSIS CASE.....	3-20
FIGURE-3.6: MAIN STEPS INVOLVED IN A CLAIMS DOCUMENTATION DISCOVERY PROCEDURES.....	3-24
FIGURE-3.7: DOCUMENT FLOW DIAGRAM BETWEEN GROUPS MANAGEMENT FUNCTIONS.	3-27
FIGURE-3.8: INTERNAL DOCUMENT PROCESSING SYSTEM USING ETVX PLATFORM	3-28
FIGURE-3.9: INCORPORATING THE CPDICENTER INTO THE PROJECT ENTERPRISE.....	3-29
FIGURE-4.1: PROJECT DELIVERY TRIAD.....	4-4
FIGURE-4.2: MAIN FUNCTIONS AND DEVELOPMENT MILESTONES FOR THE CPDICENTER.	4-6
FIGURE-4.3: SOME PROJECT ORGANIZATIONAL STRUCTURES AND CONTRACTUAL RELATIONS (ALTERNATIVE CM ORGANIZATIONS ARE ADAPTED FROM [TCCM 1987]).....	4-9
FIGURE-4.4: MULTI-GROUP PROJECTS' UBIQUITOUS AND COMPLEX COMMUNICATIONS.....	4-11
FIGURE-4.5: THE PROJECT DOCUMENT INFORMATION CENTER COMMUNICATIONS FRAMEWORK	4-15
FIGURE-4.6: ADAPTING THE CPDICENTER TO THE DESIGN BUILD ORGANIZATION.....	4-16
FIGURE-4.7: ADAPTING AGENCY CM TO THE CPDICENTER FRAMEWORK	4-17
FIGURE-4.8: CPDICENTER FRAMEWORK ADAPTED TO THE XCM (ENGINEERING) ORGANIZATION	4-18
FIGURE-4.9: CPDICENTER FRAMEWORK ADAPTED TO THE XCM (CONTRACTOR) ORGANIZATION	4-18
FIGURE-4.10: CPDICENTER ADAPTED TO THE EPCMO ORGANIZATION	4-19
FIGURE-4.11: CPDICENTER SYSTEMS AND COMPONENTS WBS.	4-21
FIGURE-4.12: CPDICENTER SYSTEM ARCHITECTURE	4-25
FIGURE-4.13: CPDICENTER DOCUMENT REGISTRATION SESSION STEPS.	4-27
FIGURE-4.14: CPDICENTER DOCUMENT REGISTRATION AND INDEXING STEPS.	4-28
FIGURE-4.15: UML MODEL OF THE CPDICENTER DOCUMENT CLASSES	4-31
FIGURE-4.16: WEBFOLDER STRUCTURE FOR A TRADITIONAL PROJECT ORGANIZATION.	4-34
FIGURE-4.17: SYSTEMS APPROACH FOR DEVELOPING THE CPDICENTER.	4-36

FIGURE-5.1: CPDICENTER GROUP WEBFOLDERS AND SYSTEM COMPONENTS.....	5-4
FIGURE-5.2: TECHNOLOGY USED IN JOINING THE WEB SERVER, AND DMID.....	5-7
FIGURE-5.3: DATABASE CLIENT INTERACTION USING ASP (ACTIVE SERVER PAGES) AND VBSCRIPT.....	5-8
FIGURE-5.4: DOCUMENT UML MODEL LINKING DOCUMENTS TO PROCESS INFORMATION SUBJECTS	5-13
FIGURE-5.5: UML MODEL LINKING DOCUMENTATION AND CHANGE MANAGEMENT.	5-14
FIGURE-5.6: DETAILED DOCUMENT FLOW DIAGRAM (DFD) SHOWS THE SEQUENCE OF FUNCTIONS FOR A SAMPLE ENGINEERING DESIGN CHANGE.	5-15
FIGURE-5.7: : PROFILING DOCUMENTS ACCORDING TO DAMAGES [HAMMAD & ALKASS 2001-A].....	5-17
FIGURE-5.8: PAPER TRAIL INVOLVED IN THE ANALYSIS OF DELAY CAUSES AND IMPACTS.	5-19
FIGURE-5.9: MAIN INFORMATION COMPONENTS IN THE DMID.....	5-29
FIGURE-5.10: CONCEPTUAL EER MODEL OF THE DMID	5-32
FIGURE-5.11: DMID EER DESIGN SCHEMA USED FOR IMPLEMENTATION	5-33
FIGURE-5.12: VERSION TRACKING SCHEMA INSIDE THE DMID.....	5-34
FIGURE-5.13: PROJECT ACTIVITIES TABLE AND FIELD DESCRIPTIONS IN THE CPDICENTER MASTER DATABASE. THE PROJECT HAS 51 ACTIVITIES.....	5-36
FIGURE-5.14: PROJECT COST ACCOUNTS TABLE AND FIELD DESCRIPTIONS IN THE CPDICENTER MASTER DATABASE. THE PROJECT HAS 35 COST ACCOUNTS	5-37
FIGURE-5.15: CPDICENTER'S DOCUMENT CATEGORIES, KEYWORDS, AND DOCUMENT DEFINITIONS CLASS TABLES.....	5-37
FIGURE-5.16: CPDICENTER CLAIM CAUSES, AND CLAIM DAMAGES TABLES.....	5-38
FIGURE-5.17: CPDICENTER CONTRACT SPECIFICATIONS TABLE	5-38
FIGURE-5.18: CPDICENTER DOCUMENT FILES TABLE.	5-39
FIGURE-5.19: STANDARDIZING DMID DEVELOPMENT WITH AN IDEF0 SYSTEMS APPROACH	5-40
FIGURE-6.1: CPDICENTER PEER-TO-PEER (P2P) DISTRIBUTED MANAGEMENT ARCHITECTURE.....	6-3
FIGURE-6.2: WEB ACCESS TO PROJECT GROUPS' CPDICENTERS.....	6-4
FIGURE-6.3: EXAMPLE OF A DETAILED DOCUMENT WORKFLOW AMONG GROUPS IN THE CPDICENTER ENTERPRISE.....	6-6
FIGURE-6.4: DETAILED SEQUENCE DIAGRAM MAPPING DOCUMENT WORKFLOWS AMONG ENTERPRISE CPDICENTER PROJECT GROUPS.....	6-7
FIGURE-6.5: CPDICENTER COMPONENTS, AND THE TECHNOLOGIES USED IN DEVELOPING THE WEBSITE QUERY SERVICES.....	6-9
FIGURE-6.6: CPDICENTER LOGON STEPS, WEBSITE STRUCTURE, SERVICES AND SEARCH OPTIONS.	6-11
FIGURE-6.7: GROUP INFORMATION WEBPAGES UPDATED ONLINE FROM THE DMID	6-13
FIGURE-6.8: CPDICENTER MAIN GATEWAY OR DEFAULT USER LOGON PAGE.....	6-14

FIGURE-6.9: CPDICENTER FRAMEWORK DESCRIPTION PAGE	6-15
FIGURE-6.10: CPDICENTER COMPONENTS WEB PAGE.....	6-15
FIGURE-6.11: GROUP GC2.1 MEMBER PORTAL USER INTERFACE FOR CPDICENTER-2.	6-16
FIGURE-6.12: DOCUMENT REGISTRATION STEPS, AND DOCUMENT INFORMATION PROCESSING.	6-18
FIGURE-6.13: REGISTRATION STEP-1 FOR DOCUMENT WORKFLOW INFORMATION	6-19
FIGURE-6.14: REGISTRATION STEP-2 FOR DOCUMENT WEBFOLDER DIRECTORY ALLOCATION	6-20
FIGURE-6.15: STEP-3 WORK DESCRIPTION PART OF THE DOCUMENT REGISTRATION PROCESS	6-20
FIGURE-6.16: REGISTRATION STEP-4 (LAST) FOR DOCUMENT REFERENCING AND ASSOCIATION.....	6-21
FIGURE-6.17: DOCUMENT REGISTRATION RESULTS ARE DISPLAYED AS RECORDED IN THE DATABASE... ..	6-22
FIGURE-6.18: DOCUMENTS AND CLAIMS SEARCH OPTIONS IN THE CPDICENTER.	6-23
FIGURE-6.19: SEARCH RESULTS FOR DOCUMENTS ISSUED BY CONTRACTORS WORKING ON PIG.	6-24
FIGURE-6.20: A SEARCH EXAMPLE IN THE TRANSACTIONS DIRECTORY FOR DELAY DOCUMENTS.	6-25
FIGURE-6.21: A DEFINITIONS DIRECTORY SEARCH FOR DOCUMENTS OF CATEGORY STANDARD.....	6-25
FIGURE-6.22: SEARCH RESULTS FOR DOCUMENTS ASSOCIATED WITH SITE-CAUSED C.O.	6-26
FIGURE-6.23: SEARCH RESULTS FOR DOCUMENTS ASSOCIATED WITH KEYWORD PRODUCTIVITY	6-26
FIGURE-6.24: SEARCH DOCUMENTS WITH ANNOTATIONS ABOUT SITE.	6-27
FIGURE-6.25: PAPER TRAILS SEARCH OF DOCUMENTS REFERENCING OTHER DOCUMENTS	6-28
FIGURE-6.26: CLAIM FILES SEARCH OPTIONS, AND CLAIMS CLASSIFICATIONS WEBPAGES.	6-29
FIGURE-6.27: RESULTS FOR A SEARCH FOR CLAIM FILES THAT HAVE BEEN REJECTED.....	6-30
FIGURE-6.28: LOOKING UP CLAIMS CAUSED BY ISSUES RELATED TO QUALITY	6-30
FIGURE-6.29: SEARCH RESULTS FOR CLAIMS RELATED TO ACCELERATION DAMAGES.....	6-31
FIGURE-6.30: SEARCH RESULTS SHOWING DOCUMENTS RELATED TO ACCELERATION CLAIMS	6-31
FIGURE-6.31: GATEWAY TO INFORMATION USED IN CLASSIFYING CLAIMS	6-32
FIGURE-6.32: SOME OF THE CLAIM CAUSES LISTED IN THE DMID AND THEIR CODES.....	6-32
FIGURE-6.33: SEARCH RESULTS FOR ACTIVITIES AT SITE GCO1 WITH PLACE TEMP IN THEIR DESCRIPTIONS.	6-33
FIGURE-6.34: SEARCH FOR BUDGET, COST ACCOUNTS, WBS, & QUANTITY INFORMATION RELATED TO ACTIVITIES THAT START WITH THE LETTERS PIG.....	6-34
FIGURE-6.35: COST ACCOUNTS FOR ACTIVITIES USING RESOURCE TYPE DOZER.	6-34
FIGURE-6.36: RESULTS OF A SEARCH FOR SUB CONTRACTORS OR SUB CONSULTANTS GROUPS.....	6-35
FIGURE-6.37: SEARCH OPTIONS FOR CONTRACT INFORMATION INSIDE THE CPDICENTER	6-36
FIGURE-6.38: RETRIEVING INFORMATION ABOUT CONTRACT CHANGES THAT HAVE REVIEW IN THEIR MEMO FIELD. SHOWS AFFECTED DOCUMENTS, AND CLAUSES.	6-36
FIGURE-6.39: PROJECT EVENTS SEARCH ALTERNATIVES IN THE SELECT MENU.....	6-37
FIGURE-6.40: SEARCH RESULTS FOR PROJECT EVENTS THAT MATCH THE CRITERIA: SITEID="NSO1", AND EVENT DESCRIPTION="STOP".	6-38

List of Tables

TABLE-1.1: ON THE QUALITY OF CONTRACT DOCUMENTS AND DOCUMENTATION [ENR 1991].	1-7
TABLE-1.2: COMPARISON BETWEEN TRADITIONAL CONSTRUCTION AND BUSINESS ORGANISATIONS.	1-9
TABLE-2.1: REVIEW OF SOME IT APPLICATIONS FROM CONSTRUCTION CLAIMS RESEARCH	2-12
TABLE-2.2: DEFINING CONTEXT AND RATIONALE FOR DOCUMENT CREATION AND MANAGEMENT	2-14
TABLE-3.1: STEPS FOR CLAIM INVESTIGATION AND ANALYSIS.	3-22
TABLE-3.2: MODELLING TECHNIQUES USED IN THE RESEARCH.	3-32
TABLE-4.1: NUMBER OF NECESSARY DIRECT COMMUNICATION CHANNELS	4-12
TABLE-4.2: KEY CONSIDERATION FOR THE CPDICENTER FRAMEWORK	4-22
TABLE-4.3: SAMPLE TRANSACTION DOCUMENTS FOR ALL STAGES OF THE PROJECT.	4-32
TABLE-5.1: SAMPLE ASP CODE EXPLAINING HOW TO ADD RECORDS USING CONNECTION OBJECTS.	5-11
TABLE-5.2: SAMPLE CODE FOR DATABASE CONNECTION USING RECORDSETS	5-12
TABLE-5.3: DAMAGE CATEGORIES USED IN PROFILING PROJECT DOCUMENTS	5-24
TABLE-5.4: CLASSIFICATION OF CLAIMS INFORMATION DEVELOPED FOR THE DMID TO CROSS-REFERENCE EVERY DOCUMENT USED IN A CLAIM FILE.	5-26
TABLE-6.1: CENTRAL .VS. DECENTALIZED CPDICENTER MANAGEMENT	6-2

ACRONYMS

- **ADR:** Alternative Dispute Resolution
- **API:** Application Protocol Interface
- **BCCM:** Building Construction Core Model
- **C.O.:** Change Order
- **CAD:** Computer Aided Drafting/Design
- **CCA:** Canadian Construction Association
- **CCDC:** Canadian Construction Document Committee
- **CIC:** Computer Integrated Construction
- **CM:** Construction Manager/Management
- **CORBA:** Component Object Request Broker Application
- **CPDICenter:** Construction Project Document Information Center
- **DCOM:** Distributed Component Object Model
- **DMA:** Document Management Alliance
- **DMID:** Document Meta Information Database
- **EC:** Execusable Compensable Delay
- **EDM:** Electronic Document Management
- **EDMS:** Electronic Document Management System
- **EN:** Execusable Non Compensable Delay
- **FAR:** Federal Acquisition Regulations
- **GUI:** Graphical User Interface
- **HTML:** Hypertext Markup Language
- **IS:** Information System
- **NE:** Non Excusable Delay
- **ASP:** Active Server Pages
- **DIS:** Document Information System
- **DTD:** Document Type Definition
- **HTTP:** Hypertext Transfer Protocol
- **ISO:** International Standards Organization
- **IT:** Information Technology
- **KBES:** Knowledge Based Expert System
- **MIS:** Management Information System
- **O.H.:** Over Head
- **OBS:** Organizational Breakdown Structure
- **ODBC:** Open Database Connectivity
- **ODMA:** Open Document Management API
- **O-O:** Object-Oriented
- **PCWBS:** Project Commitment WBS
- **PDCH:** Project Document Clearing House
- **PDM:** Product Data Management
- **PDT:** Product Data Technologies
- **RFI:** Request for Information
- **RFP:** Request for Proposal
- **SDAI:** STEP Data Access Interface
- **SGML:** Standard Generalized Mark-up Language
- **STEP:** STandard for the Exchange of Product model data
- **VE:** Virtual Enterprise
- **WBS:** Work Breakdown Structure
- **WP:** Workpackage
- **XML:** eXtensible Markup Language

PREFACE

This research presents a framework and the necessary information system architecture for implementing a web-based solution for the main problems that claims analyses face which include: lack of contemporaneous documentation from the construction operations, and finding and retrieving those documents, which cover the history of the project operations. The solution proposed is entitled the “Construction Project Document Information Center” (CPDICenter). The CPDICenter is a Document Information System (DIS) to manage documents, and its information models are scalable and extensible to meet any project structure with any number of participants who may be diffused over distant geographical areas. The research findings are equally applicable to all project types, such as building projects, civil projects, or product development.

Large Construction projects involve complex processes, big budgets, many professionals, many specialty trades, as well as expensive equipments, and material resources. Managing these undertakings requires extensive technical experience and, often times, managerial and organizational art on the part of the construction manager. Research into the construction delivery intensified in the last decade providing management solutions, mainly in the shape of management tools and control techniques to identify and control construction processes and problems that may result from unforeseen or foreseen risks alike. One area research has served and continues to focus on, is construction claims. Claims are requests submitted by some project group (commonly the contractor), to another group (e.g. the owner), to compensate for any

performance deterioration or delays inflicted by disruptions to work processes, or changes to quantities, or additions beyond scope, or sometimes omissions. Without relevant contemporaneous documents from the construction periods in question, proving the effects (impacts: delays, and cost increases, or losses) of such causes will be a plausible task. In normal circumstances, the lack of congruous construction documents to explain the problems of the operation might lead to the loss of the claim(s). Impacts to the construction performance—inflicted by external or internal causes—have always been a big concern to owners, contractors, and engineers alike. In part, that is due to the tremendous capital tie-ups and the possibly forgone investment opportunities each project group endures. Also because of the high costs needed to prepare claims, establishing responsibilities, and estimating the impacts' damages. Hence, Contemporaneous construction documents are crucial for accurate claims analyses.

Currently the industry is not unanimous on any methodology or information system architecture for controlling and storing “every” project document, from all groups, as future references in cases of impact claims. The solution proposed here— the CPDICenter—streamlines documents, vis-à-vis project phases and document viewing rights, into four classes. The CPDICenter also offers a web-based document information database and a storage architecture that ensures access to documents throughout the project organization. The database will hold Document Meta information, and hence the database is entitled the Document Meta Information Database (DMID). Meta here means information about information, or information about documents.

The Information architecture will define the way the document and project information are related, and where and how to store documents for fast retrieval. This web-based solution promotes a uniform view of all project documents. It is also adept to any project delivery or organizational system like Construction Management, Traditional, Design-Build, and Owner-Builder. Every CPDIDCenter shall include the database component (i.e. the DMID), Document Webfolders for project groups, search indexes, parametric searching facilities, document registration (profiling) forms, and a database holding project process control information. The groups' document Webfolders have preset directory structures that are consistent for all project groups.



Chapter One *Introduction to the Problem of Documentation and Support for Claims Analysis*

1.1 – *Background and Problem Domain*

Timely and accurate project information is the cornerstone of successful claims resolutions in today's fast-paced, information-intensive projects. In broad terms, the documentation is essential to support claims management processes: damage analysis, reconstruction of facts, As-Built schedule production, delay adjustments, and establishing impact causes. During litigation planning claim analysts will rely on documentation to define the disputed issues, establish production facts, plan a case scenario, and for depositions, interrogatories, and in defining contractual parameters that control parties' actions or inactions. Moreover, documentation is instrumental for discovering the relevance of a claim, establishing a damage value for the facts under dispute, setting up a credibility standard for proof of entitlement, ascertaining the impacts or damages, and supporting claims for additions or omissions for changes. However, care should be exercised in order to include within the documentation's scope documents prepared by as many trades as possible—even if those trades appear as not involved in the dispute. [Vicerich 1992] finds that consistency, or the lack of it in such cases, provides an evidence of the project circumstances and events. As such, inconsistency will assist a

project's owner find whether the contractor's baseline schedule and estimates were logical and reasonable to begin with, or to find normal productivities during periods that are not supposedly impacted. Such information is at the contractor's disposal and the owner has to go through a discovery stage to collect such information.

1.2 – Affected Project Groups

All project groups are susceptible at one point or another to become involved in a claim. Suppliers, sub contractors, trades, consultants, and owners alike, need quick and easy access to the wealth of knowledge that exists within the collective documentation of the project operations, in order to make sound claim decisions and realize their damages. Project document retrieval is at the core of this initiative, and this effort requires the establishment of an information and knowledge structures to map all project documents and their contents. The CPDICenter is a Web-based application that will provide two main services: 1) document registration functionality, and 2) document search and retrieval. Both services can be carried out over the Internet, or the project's intranet. The CPDICenter does away with information barriers, allowing the project organization to access and share critical documents regardless of their MIS (Management Information System) platforms. The CPDICenter's system architecture, and workflow models are expected to transform vast amounts of disparate documentation into organized and structured sources, by capturing, organizing, classifying, and storing those documents in the DMID (Document Meta Information Database), for fast retrievals based on the information or knowledge used to classify those documents by the project members. The CPDICenter offers a centrally accessible repository for critical documents.

1.3 – The Documentation Problems in Construction

In recent years, construction performance-related disputes have shown an increase in their preparation costs and times. Claims and disputes not resolved through negotiations are pursued in different venues—the Alternative Dispute Resolution (ADR) stepwise approach of mediation, arbitration, and litigation, in that order [Torone & Kreitzberg 1994, Findley 1997]. Much of the costs involved in setting up a claim for remuneration goes to the search and retrieval of documents and historical information about the project. Claims analysts estimate that to be 70 to 80% of their professional time [Tardif 1997]. In other industries project members need to spend around 50% of their time looking for documents that should have been classified in the first place [Feldman 2000]. This problem takes a more critical posture especially when 75% of any organizations' information is contained in unstructured (non-database) formats—documents, transactions and reports [Gross 2001].

As a general practice, preparation of Impact Claims is carried out after project completion. At such times most construction participants would have left for other project opportunities, and with time the memories of those who were involved in the project fade or become fuzzy. The dissolution of any construction project temporary organisation makes it very difficult for analysts, who commonly join after the project ends, to comprehend and understand fully what really took place during production periods, also they can easily overlook minute, yet important, details about those production events. The “Modus Operandi” in the construction industry is to carry out claims analyses with little or no input from the engineers or site managers who were

directly involved in the construction process. Of course, one could argue that such an input from project participants is in the reports and other documents they left behind, particularly when the production of such documents was part of their managerial duties. However, without a project system to control documents and information, the documentation exercise will not be structured, and often times not complete, and that in turn makes the dissemination of rational and valuable information a costly process.

Negotiations amongst claim parties fail mainly because they are not sharing a common view of the project information, or not in step with each other's status as per production and progress. A common view of the project is possible, if and when a central project information system is up and running for project groups to tap into. Meaningful project history resides either in documents—hence document-based—and/or with that project groups' collective memory, because no one alone can understand all the events and their circumstances or is able to present all aspects of the construction operations. However, with the conclusion of construction activities, most site echelons, engineers, site supervisors, and others who are directly involved in the building exercise, move to other ventures, and eventually when their opinions (testimonies) are needed, they are not easily and cheaply tracked, moreover, people's memories may fade.

The fierce competition for new projects, and the increase in projects' complexity forced contractors' profits to marginalize and stay within low percentages, sometimes one percent or less [ENR 1991]. The recent decline in contractors' profits is represented in Figure-1.1. Contractors' slimming profits have directly, or sometimes indirectly, gave

contractors an excuse to evade investments in Information Technology (IT). As a fact, contractors assimilate and generate the bulk of the information in a project inasmuch as they are directly involved in the construction processes. Their capability to set-up a project and choose the methods they see most fitting, adds to the list of reasons of why contractors should be involved in any Electronic Document Management System (EDMS) development in construction. Construction EDMSs need further study and research to support claims analysis search functions, and presentation—a motivation for this research. Claims analysts rely on document-based evidence to find facts about claim causes, effects, and related contract-borne entitlements. Legal interpretation of facts, however, is beyond the scope of this research.

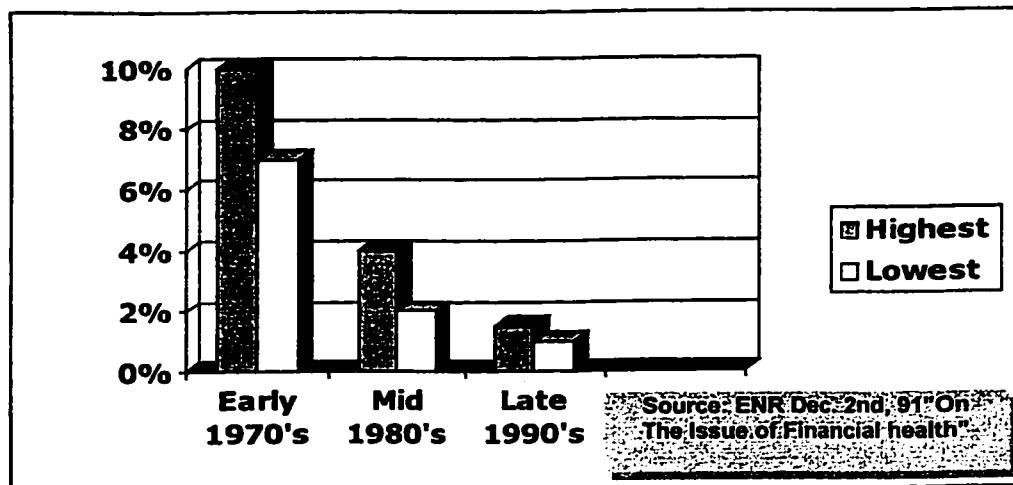

Figure-1.1: Slimming contractors profits in the last two decades

1.3.1 – Claims Preparation and Document Management Problems

Analysis of claims demands extensive documentation of project operations and processes. Most analyses, however, takes place after the fact, or after termination of works. At that time, the information needed for analyses are mainly residing in

documents. This elevates the importance of document gathering, their organisation, and classification. To that end, current practices are far short of providing any reliable consistent, and conclusive documentation. Documentation for a project starts the moment an owner—private or public—initiates a feasibility study, and further down the line prepares tender invitations and site tests for the prospective bidders. The selected bidder or group of bidders are bound by contracts, the language of which will shape, amongst various things, the following:

- Project organisational structure.
- Contract valuation or remuneration system (e.g. Cost-plus, Unit Price, Stipulated).
- Claims Management, documentation and workflow, which include:
 - Rules of documentation.
 - Cost reimbursement method.
 - Entitlement.
 - Dispute resolution mechanism.

Contractors' opinions about contract documentation were the subject of a joint survey [ENR 1991]—reproduced here in Table-1.1. The study clearly indicates a need to improve the quality of project contract documents, which are the main guideline for project control. However, most contracts in the market today are tailored for the traditional project delivery [Short 1997], where the owner retains a consultant for design and engineering, and consequently when design is completed contractors are invited to bid based on a stipulated price basis.

Table-1.1: On the quality of contract documents and documentation [ENR 1991].

Contract Issue	%
Fair to Poor Quality of Contract Documents	52%
Specifications Have Major Omissions	84%
Documents Need at least one Modification	65%
Documents Needed Frequent Changes	50%
Changes to Documents Needed	55%

Claim clauses will never fit all possible situations, or organizations. These clauses are viewed by the industry—particularly owners—as an exculpatory language [Jensen et. al. 1997] to shift risks to the contractor. Rigid interpretation of claim clauses can drive some contractors into bankruptcy. Claims management documentation requirements, if any exists, sometimes lack specificity and do not convey the real requirements in an unambiguous language. It seems, according to some experts [Revay 1995], much of the seeds of disputes are planted in the pre-construction phase when the contract clauses are prepared.

Claims are not all quantified during a project's life; some are actually left intentionally till the end of the project, just to be able to quantify the real impacts to cost and schedule. Nevertheless, there remains the task of documenting daily operations, especially for any post-construction analyses. Such analyses have to have quality data and information to make the readers (e.g. claims analysts, mediators, arbitrators etc.) abreast with the true context that surrounded certain disputes or project events, and if possible, the rationale behind certain key decisions and changes. Can documents capture context and rationale from a construction process? This research focuses on solving this critical problem, and presents a solution to fulfil such a requirement.

Documents can become veritable project chronicles and history narrators, if the context surrounding each and every event in the construction project, as well as the rationale behind any decision, or the cause for any discourse from baselines is recorded. A closer look at the project organisation, offered here in Table-1.2, reveals some interesting contrasts vis-à-vis the Business Organisation. Such distinctions are domain-related, and understanding them does benefit, thereof, the search for an IT solution for project document capture and management. One should always bear in mind that construction is a temporary organisation of strangers, with competing paradigms. The owner for example is in for the best product with the least cost; the contractor is there to expend the least effort for the most revenue. The foregoing situation should not be advocated or fostered, however.

1.4 – Scope Of Research

The focal point hereto after will be the documentation of construction operations; this includes the storage and retrieval of contemporaneous construction documents. Contemporaneous documents support the entitlement of claims quantification at any stage of the dispute. The system envisaged in this thesis—to manage documents—has to adapt to any construction project type (Civil, Building, Industrial, ...etc.), and to any number of participants. Hence, a multi-party enterprise of owners, contractors, subcontractors, engineers, suppliers, and interest groups, will be accommodated. The system is concerned with data used to manage construction operations as well as the data resulting from such management processes.

Table-1.2: Comparison between traditional construction and business organisations.

Construction Organisation	Business Organisation
Short term, limited life span (years)	Long term, long life span (decades)
Business Relations last for the project	Long term relations, strategic alliances
Client is known before hand	Clients are profiled and segmented
Operation and Process-Oriented	Evolves around a product or service
Intensive Knowledge in specific domains	Wide base of Knowledge pool
Errors have to be surmounted abruptly, or ripples will distribute to other parts	Errors absorbed through long term training, reengineering, and adaptation
Time is of essence	Return on investment is of essence
Non persistent, temporary organisation,	Stable internal structure
Project-oriented management	Products are becoming like projects
Performance measurement is in reference to planned productivity or baseline	Performance measured in reference to the previous stage, quarter, year.
Innovation motivated by lowering operational costs	Thrives for customer satisfaction Innovation in specifications and delivery.
Quality is vague, and relative	Quality is well entrenched in the system.
Competing paradigms, higher rate of conflicts	Competition over functional resources and hierarchical recognition
Participants have different informational needs	Information view varies among functions. Information model is uniform
Customer is an important partner	Customer is external to the organization
Compatibility amongst participants' information systems is merely a sign of good-luck!	Even with geographically diffused operations, Compatibility is a must to function as one integral entity

Documents Meta Information should include the context in which they were created, plus the operators'/managers' rationale or interpretations of current states and the sequence of events that preceded. Pre-construction documents are considered references, scope definitions, and sources of “Business-Rules” for claims documentation, and documents’ workflow. In a more focused manner, this research will:

- Develop information architecture for capturing and managing construction document transactions between all project participants. This entails classifying all documents—such as exchanges, transmittals, meetings, directives, methods, videos, CAD...etc.
- Create a Document Meta Information Database (DMID) that works as a document repository, and could be accessible via the Web or a Local Area Network (LAN), that should expedite the retrieval of documents.
- It will also account for information pertaining to claims documentation procedures, and relations between project objects/subjects’ information

1.5 – Research Motivation

This research aims at creating a Document Information System for construction project organizations in order to capture, organize, and store documents generated for and by the construction processes/tasks/events. Pre-construction documents (e.g. tender invitations, contract agreements, conditions, specifications, bid estimates, etc.) are considered as references and project definitions, and in some instances play the role of guidelines. Document classification will be based on those documents’ functions, and their project stage. The need for this research is identified by literature reviews,

surveying experts' opinions (Appendix C), and author's personal encounters with project documentation for various types of claim cases.

1.5.1 – The Need for a Solution to the Documentation System Problems

Documents are necessary for claims preparation because they establish entitlement, causes, effects, and damages for changes, omissions and similar disruptive problems in construction. The need for an Electronic Document Management System (EDMS) solution to the problem is identified by researchers and outright experts [Edwards et. al. 1996, Baram 1994, Harmon & Stephan 2001] in order to manage documents, cross-reference them, and store them properly in databases. Documenting and presenting project facts are a necessity for the credibility of a claim [Baram 1994]. In a study by [Elnagar & Yates 1997] they surveyed experts' opinions to classify the documents that assist in identifying delays in a project. In another study by [Kangari 1995], numerous arbitrators were surveyed for opinions about the importance of project documentation; he found that contemporaneous documentation is sometimes more credible than human expert depositions. He also found that in many cases claims are lost because certain parties could not provide documentary proof from their part in the project operations. Productivity is yet another critical information for estimating project costs and is commonly retrieved through analysis of project staffing records and labour utilization charts [Leonard 1987]. In a legal opinion by [Jensen et. al. 1997], it's been shown that constructive accelerations are always substantiated with a host of documents that capture the production events and facts of the process circumstances. Documents are also necessary for the management of projects and control of process workflows [Ndekugri &

McCaffer 1988]. However, documents are not always available, or are missing, or are not properly cross referenced to project activities and information subjects [Tardiff 1997, Schroedel 1997]. Lack of documents always affects the results and integrity of claims analysis, especially in critical issues like delays [Baram 1994, Alkass et. al. 1995, Mazerolle & Alkass 1993]. Defensive documentation necessitates a system to control documents or store them in a way that simplifies their retrieval [Schroedel 1997, Powell-Smith & Sims 1985]. A report by [Revay 2000] indicates that with the current advancements of computers, claim experts are spending ever more money to have more exhibits to prove their stand points, and for that at least a million dollars is expected to be spent to ensure the scanning of “all” Project documents. [Revay 2000] also goes to note that claims preparation is much more expensive that it used to be. According to [Harmon & Stephan 2001] it is not unheard of to spend years going through discovery and spending millions of dollars in legal and consulting fees trying to get all of the facts understood and boiled down to the key issues to be discussed at trial. Therefore, collecting “all” of the documentation electronically can substantially reduce this problem. Although the distinction between search and analysis is not clearly delimited in the minds of the analysts—because of the overlapping and repetitive nature of this work—still there is an estimated 80% of an expert's time spent searching for information in documents or about documents [Hammad & Alkass 1999-a]. In Claims analysis there is always the chance of missing critical documents that would severely affect the analysts’ stipulations.

The possibility of overlooking important plans and/or documents that other parties may present at arbitration or litigation, always exists. Such problems were also a

motivation for installing a system to control project documents for the Kawloon Airport in Hong Kong, in anticipation of claims or disputes [Boughthon et. al. 1997, Archer et. al. 1997].

In order to get to the crux of the documentation problem and to touch base with the industry, the author of this thesis interviewed (see questionnaire in Appendix C) twenty (20) claim experts, and construction managers using a direct (one on one) interview-survey format. Respondents were encouraged to express their opinions and to guide the questionnaire to issues that are most pressing from their (experts') perspective. The questionnaire exhibits are available in Appendix C, which include samples of: 1) the introductory letter sent to most experts, 2) Meeting Agenda, 3) Questionnaire's list of inquiries, and 4) users' requirements website questionnaire. The results of this questionnaire are summarized in the following sections highlighting the problems that project documentation suffers from. The user specifications pertaining to search and retrieval and website navigation are incorporated into the CPDICenter website design (Chapter 6).

1.5.2 – Results of Experts' Questionnaire on the Issue of Supporting Documentation for Claims

Documenting the construction process depends on the type of project at hand, and the IT used by the parties in managing and organizing documents. Nevertheless, many of the problems listed hereto after are common and can, safely, be generalized. They are detected by attending interest group seminars at AACE symposiums, Construct Canada

annual Seminars, online web-based seminars and claims workshops, and direct encounters with factual documentation for construction claims. Also through extensive literature reviews and meetings with twenty (20) experts from companies, consultant firms, institutes, or organizations including: Hatch and Associates, ABB, Bechtel Saudi Arabia, Consolidated Contractors Corporation (CCC) Europe, Public Works Division of the Ministry of Public Welfare in Kuwait, Department of the Built Environment at the University of the West of England UK, PCL Inc. at Calgary, Contract Management Association USA, GTE communications USA, Revay and Associates claim consultants in Montreal, and Tardiff and Murray claim consultants in Montreal. See Appendix C for samples of typical expert meeting questionnaires. Every expert was first addressed with an introductory letter before the meeting to highlight the issues to be discussed and then set an agenda for the meeting. The meeting sample questionnaire is handed over to the expert at the time of the meeting for replies, comments, and discussion. The results of this expert opinion solicitation resulted in a better definition of the documentation problem, the technologies those experts use in their attempt as to solve the problem, as well as understanding the main steps in any claim analysis and user specifications for the future web-based document centre or portal (i.e. the CPDICenter). The results are represented in this section, and section-1.4.3, and 1.4.4. Some of the observed documentation problems are:

- Redundant information, and repeated information.
- It is sometimes impossible to tell if any documents are missing.
- Many documents are hand written, making them hard to read or understand.
- Final status on issues like Change Orders (C.O.s) not always evident.

- Indexing is not readily available, or non-consistent across the project.
- Documents are not traceable to the issuing body or person who wrote them.
- Documents are not classified in a structured manner.
- No clear paper trails of the documents, or where or why they are written.
- Poor registration of critical events like delays, disruptions, and accelerations.
- Not using a standardized format for reporting construction process information, which affects the quality and integrity of the information.
- Each group in the project uses different forms for the same type of documents
- Cross-linking amongst related documents does not exist.
- Different documents of different types or names may have the same content although with different forms. Hence, versions of the same document may, mistakenly, not be related.
- No record to show version numbers, and evolving reviews at the time.
- Required signatures, and reviews before release are not included, and instructions for distribution not known.
- More than one version of each may be in existence making it even more difficult to reach a resolution on the true status of an issue.
- Missing important workflow instructions for distribution, and specific requirements of each case or claim issue.
- Distribution of documents suffers from duplication and inconsistencies.
- No information framework to handle changes to project organization, contract arrangements, or documentation business-rules pertaining to claims.
- Documents are not cross-linked to critical documents such as specifications, drawings, claims clauses, meeting resolutions, or contract changes.

1.5.3 – Current Challenges Facing Documentation for Claims

- Documents are an extremely valuable tool to capture construction process information. In many views, they are basic wrappers of information, providing physical ties between dispersed, yet related, data bits from all over the operation. They can be at such a level of granularity that any development in their management, creation, distribution, and storage, is indirectly managing the construction project information. To muster a document retrieval solution, the documentation and claims business practices (concerning changes, disruptions or delay issues etc.) have to be analysed.
- Analysis of claims is oftentimes carried after the finish of a project—sometimes by choice or due to lack of information—to find out objectively the value of the impacts to performance. Project participants leave the project after its finish and after a long separation from the activities; memories fade and become selective. This makes the proof of a cause very hard. Usually it is harder to prove claims after the construction project has finished, especially by Analysts who are foreign to the exact events of a specific construction process. Even though hindsight knowledge of true impacts is helpful, their remains, however, the documentary proof to support certain views and scenarios of causes.
- Without comprehensive, structured, contemporaneous, cross-referenced, and organized documentation, cause-effect relationships take longer to establish. Due to legal provisions documentary proof of causes and effects is necessary.
- Contemporaneous and shared documents carry more weight, and are highly admissible to the dispute resolution process (like mediation, arbitration, or litigation). Sometimes those documents are more likely to change the outcome of a claim than would a human expert [Kangari 1995].

- Construction professionals are not trained to document or chronicle construction events like: changes, disruptions, or interferences by an owner. They might not be trained, as well, to identify key elements of an event that are documentable for a later examination.
- Ad-hoc filing structures are used to store documents. This entails longer times to retrieve crucial data from documents, and analysts will not be sure if any documents are missing, and if lost where to look for them.
- Currently there is not a project-wide standard for project DIS (Document Information System) in use that is purposefully made for the project as an enterprise of multiple groups, stages, and contracts. Furthermore, what is available in the market (see Chapter-2) offers limited ability to document the context and rationale behind any divergences from planned baselines, schedules, or budgets.

1.5.4 – Diagnosing Construction Documentation Systems Problems

In construction projects, documentation is a management function that is considered an errand or one of the contract administration chores. Construction groups (e.g. General Contractor (GC), Owner/Client, Engineer, or Designer) carry their documentation functions differently, based on their technical capabilities and level of involvement in the project operations. Moreover, different project groups require different levels of detail from each other. For instance, the owner looks for measures of progress that are global in nature and less detailed; the GC needs more detailed information to manage or mitigate impacts to its crews' performance. For example, the contractor(s), sub contractor(s), consultant(s), and Owner, each one can run its own Management Information System

(MIS), with proprietary databases designs to represent project information. The normal case is for each of the parties to incorporate the project within its internal MIS and DIS. This practice has proven to be inefficient and expensive to run. Its inefficiency stems from the high cost necessary to overcome some technological hurdles such as communications, data exchange standards, compatibility of conceptual or design database schemas, and geographical dispersion of operations. Each group is expected to keep enough records to prove its claims or defend against ones. However, much of the information collected is contractor-generated, and this information is usually shared with others in the project according to contract's stipulations. For example, . In general, contract clauses are necessary for enforcing, and sharing of process information on a routine and succinct basis. Here is a list of some of the underlying causes for documentation problems in construction projects:

- Not using any DIS to control the issuance, distribution, and storage of reports, transmittals, and other documents.
- Lack of cooperation between project groups' DIS because of incompatibility.
- Data models to represent relations among project objects (information subjects) are not available. Well-developed persistent data models are precursors to database design.
- Conventional filing systems are used instead of Databases to control and track documents' Meta information.
- Document version management is not used.
- Limited capabilities for timely and accurate issue status reporting on.
- Many of the documentation tasks are manual, and paper-based, further complicating document workflows.

- Limited use of standard or customized document forms.
- Not enough clauses to encourage or make compulsory proper and extensive documentation.
- Varying technical capabilities amongst project groups
- Hesitation by certain groups to share documents, or invest in a project-wide document tracking, and retrieving system [Boughton et. al 1997].

1.6 – Types and Nature of Construction Documents

There is normally a body of documentation that precedes the start of operations, and has an impact on the rest of the project. Figure-1.2 shows how documents accumulate from inception till project commissioning or delivery. There is no established rule as to the effect of the size or value of the project to the number of documents that will be generated as a result. Even when most documents are generated from computers, yet they are copied many times over and eventually reside mainly in paper. Medium size projects (\$10 to \$ 30 million dollars) are expected to generate around (12,000 to 20,000) documents for each \$10 Millions, depending on the complexity of the project. That is if we count only a single copy of each document. In general, there are no persistent relations between the claims amounts or the project size and the number of documents. As a general perception by claim analysts or consultants surveyed in this research, a consensus leaned towards 1000 documents per 1 million dollars in project value. Hence a project of 12 million dollars might generate-in total-about 12,000 documents, which includes correspondence, and documents that groups use internally for the purposes of the project. These numbers are subjective, however. Any severe or inadvertent problems like changes to scope will increase the correspondence within the groups themselves and

across the project. Eventually this sends the total number of documents accumulated in a steep incline. In general, the trend is a continual increase in accumulated documents with time as depicted in Figure-1.2. In general a project life cycle has the following stages: 1) Planning, 2) Definition, 3) Design, 4) Tendering, 5) Construction, 6) Commissioning, 7) Operation, and 8) Decommissioning to owner.

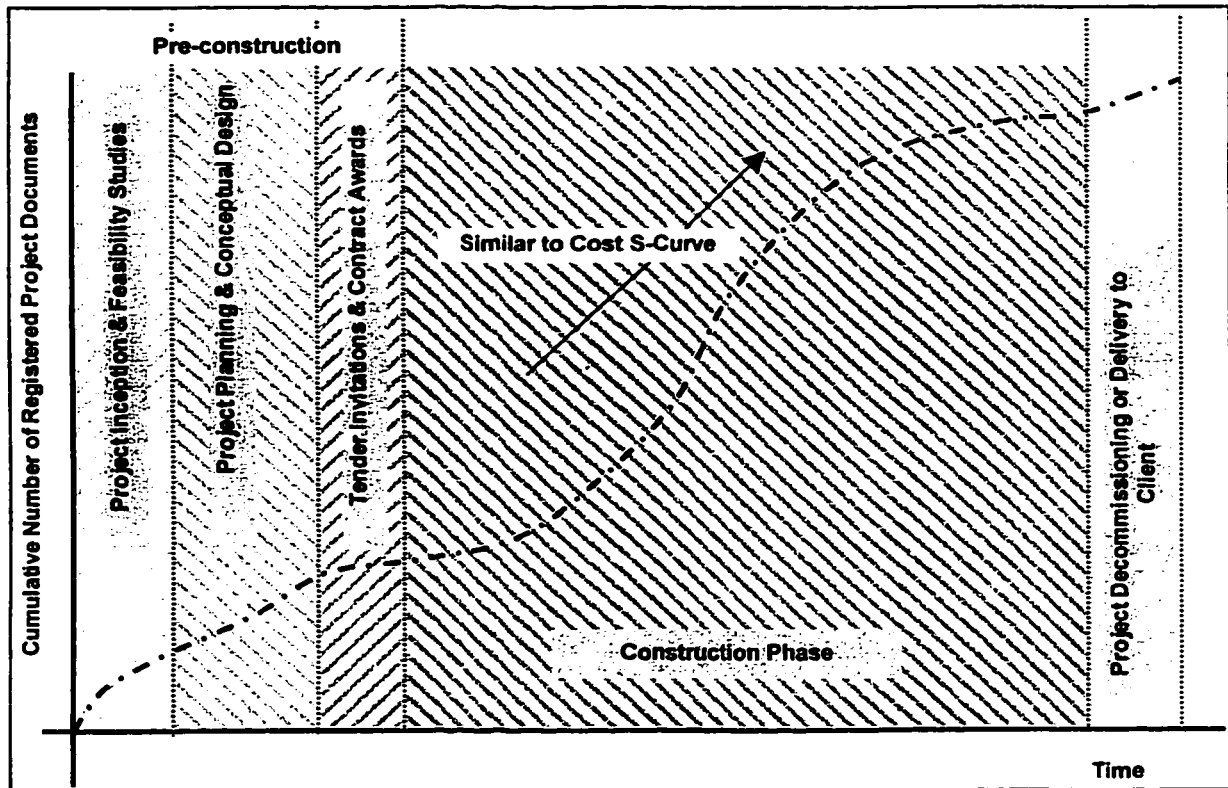

Figure-1.2: Build-Up of Construction Documents During a Project's Life

An extensive list of common document titles for Pre-construction, and construction stages are enclosed in Appendix A, and are used in the development of the DMID. Also enclosed in Appendix A, are common clauses from contract conditions and agreements. In addition, Appendix A includes a description of the four main document classes

(Transactions, Proprietary, Public, and Definitions) devised exclusively in this research to control documents' Meta Information.

The extent, with which documents can impact construction operations, depends on the project delivery system and how risk and liability are apportioned amongst contractors, consultants, and owners. In its simplest forms, project delivery is made up of three elements: Management method, Contract Type, and Project Organization [Moselhi 1993] By and large the language of the contract imposes limitations on any contractor, sometimes immense. As an example, a turnkey contract with a stipulated price (e.g. Lump Sum), without clause/stipulations for delays or impacts, is a stiff set-up for any contractor. Contracts provide imminent clauses to control disputes and the key documentation to prove impacts on performance. They include as well the valuation system to quantify claims (e.g. total costs; differential method for delay costs; Eichelay formula or per-diem for Over Head...etc.). They provide also, rules for document processing, maximum time for replies, and dispute resolution methods. Ready-made contracts can be used, such as the ones offered by professional associations; in Canada, for example, there are various societies that offer contract forms, such as:

- The Canadian Construction Document Committee CCDC.
- The Canadian Construction Association CCA.
- The Professional Engineers of Ontario and the Committee of the Canadian Architectural Councils.

In the US, some of the standard contract forms are offered by:

- The Engineer's Joint Contract Documents Committee EJCDC and the American Institute of Architects AIA.
- The Federal Acquisitions Regulations FAR.
- The U.S. Department Of Transportation & Federal Highway Administration.

1.7 – Handling of Claims' Documents by Claims Analysts

To a claims analyst, or a construction manager, documents are never considered as black boxes, to the contrary most dispute analysts will read hundreds of pages or thousands to get a clear picture of the construction events, and to understand the causes of impacts to performance. Documents' contents, therefore, are of principal value. Such a realisation will be translated into more data fields in the DMID in order to let the user more input and classification about the contents of each document. This is expected to offer the document searcher various ways of finding the same document, because it will be referenced by project subjects, such as: a project cost account, WBS, an activity, a resource etc. The objective is enhancing the chances for the forensic expert to find more relevant documents with more contexts and more transparent interpretations of construction events.

Claims has four main components: 1) establishing causes, 2) identifying effects, 3) providing supporting entitlement for compensation, and 4) quantifying damages. Claims in the most part are left for after-the-fact analysis, due in the most part to the lack of

documents or information at the time. By then, adjusted As-built schedules and plans can be generated to measure the impact of the delay or disruption or change, as the case may be. Claims Analysts and management teams make a clear distinction between facts and the legal interpretation of those facts. Facts pertain to impact causes, and resulting damages. Analysts offer many services and are generally retained for claim preparation and litigation support by many parties, for example:

- Owners: Private or Public.
- Main Contractors and Subcontractors.
- Surety, Bonding Agencies, and Financiers.

1.7.1 – Claims Preparation Process and Document Classification

The moment experts are retained they review the contract documents to establish all the contractual relations, obligations, commitments, and the corresponding entitlements that go with them. Pre-construction documents (e.g. bid quotations, soil tests, disclaimers about delays in the tender documents...etc.) all are recalled to the expert's facility to understand the issue from the ground up. Subjective evaluation of claim delays or impact adjustments sometimes is not escapable. This is due to the fact that documents are not always comprehensive, or the nature of the impact is not directly clear. Analysis bottlenecks exist, especially while apportioning concurrent delays, or quantifying extended overheads. Also when there is an acceleration that was ordered and partially implemented. At such occurrences, an analyst's experience will jump right in to limit the

scope of the problem, or to establish the feasibility of the claim action, or to find for how much to claim, or to pursue a claim at all.

Analysts receive the client's documents—in most cases the contractor—and will solicit more documents from the client affiliates (e.g. subs, suppliers, lenders...etc.) in order to complete the picture. The complexity of the project organization would complicate the tracking of documents.

Some of the problems that develop in large organizations:

- Duplicated effort, and wasted resources.
- Different versions of the same document distributed to different parties.
- Updates and versions are not uniform across recipients.
- Partial distribution of documents, and incomplete paper trails. Different parties collectively could present the whole picture, but no one could establish the paper trail independently.
- Missing documents.

After receiving what the contractor has, the analyst sifts through the documents for peculiarities and a general overview before solving the conundrum. The documents are then indexed objectively and subjectively. Objectively means to index by date (from; to; by; serial number...etc.) Subjectively, on the other hand, is based on a conceptual model of the project's WBS, or by issue, or by specialty or trade domain. The purpose is to reference (e.g. to mechanical, schedule, delays, material, testing, costing, payments, inspection...etc.) each document and classify its role in the analysis procedure yet to commence. Because of this indexing effort, the analyst gets to review all the documents,

and meanwhile find if any documents are missing. Whatever is missing is flagged for further inquiry with the client.

1.7.2 – Expert-Generated Documents: Organisation and Inference

After reviewing the available documents, some understanding of the project's history is created. This aids in relating documents to the three main components of claim analysis—namely: cause, effect, and entitlement. After taking inventory of all authentic contemporaneous documents at hand, the analyst generates his/her own set of documents, which may include:

- As-built schedules showing actual daily progress, stoppages, and disruptions.
- Adjusted As-Built Schedules (adjusted with delays and task changes from reports), and entitlement schedules.
- Summary list of key documents or priority correspondence.
- A menology of milestones/important events with commensurate documents.
- Correspondence and transmittal logs.
- Lists of schedule-related documents.
- Lists of Claim files, and Change Orders (C.O.)
- Roster of Exceptions and Non-Conformance reports
- Inspection reports and Attestations of quality
- Lab test results.

1.7.3 – Comments about Document Handling during Analysis of Claims

The whole exercise is predominantly manual, except for the use of word processors for summary writing, As-Built schedule plotting, and isolated uses of some ad-hoc document-management programs intended for legal professionals. It has become clear after some time that Claim Analysts spend a considerable set-up time to gather and organize data about documents that they have in hand. This data is known to researchers in the MIS field as the “Meta Data” or “Information about Information” [Kerzner 1998]. In the vast majority of construction projects, the WBS, and the Cost Accounts are not uniform across the project—if any is implemented in the first place. The general contractor may be following a WBS that is different from the one used by other parties, and the same applies for the cost classification or the cost coding structure. Project Commitment WBS (PCWBS) that identifies the work packages and cost centers does not always match the original WBS that the contractor may have bided on. Therefore, documents carry, sometimes, references that are not uniform across the project, and each party might follow its own referencing scheme. Current practice does not give enough attention to this issue and even in big contracts, we find contractors not using a WBS to begin with.

All documents have to be admitted to an attorney at law, who will issue an affidavit of all documents listed and found. Exchange of documents amongst claim appellants is possible through a process of discovery—given that they know what they are looking for. Only copies are exchanged, however. Summary lists are made for all documents at hand, and held by attorneys from both sides as references. These lists do not follow a specific

checklist or format and can be classified randomly (i.e. no chronological order used for documents) for various reasons. Parties to a claim, if they know what they are looking for and get the proper court discovery order, need to photocopy (Xerox) the whole set of documents repeatedly, which presents an extra cost.

It is preferred to support claims by documents that have been shared during the project— for admissibility reasons and because priority goes to documented and shared information. If shared documents are not enough, next best is to use whatever is available, such as: procurement or purchase orders, staffing logs, resource aggregation charts, management instructions, and internal memorandums, to name but a few. Sharing of documents can always be part of the contract clauses, An example for a traditional project delivery can be by stipulating that the owner shall not release funds to the contractor without the submission of expenditures and staffing reports by the contractor and/or his subs. Sharing of documents can alternatively be achieved if the relationship amongst project groups is based on trust and open or honest communications.

1.8 – Research Objectives

Based on the foregoing arguments and discussion about construction claims' documentation, it has been realised that there is a need to make use of the current advancements in IT and the recent advents in web communications standards, and therefore, propose for development the following:

- A new framework for a document information system to control, store, and retrieve all documents generated during the delivery processes, and from all parties in the project.
- Design and construction of the Construction Project Document Information Center (CPDICenter) system Architecture and identify the main system components necessary to support functions like: document workflow and transactions, database location and replication, search engine, and groups' document webfolders to house their project documents.
- Design and model the CPDICenter framework as a Web-Based implementation to take advantage of the new Internet standards that promote a consistent way to exchange information amongst applications.
- Design and develop a database to capture and hold Meta information about documents DMID (Document Meta Information Database).
- Design and organize the CPDICenter website (prototype) which will work as a proof of concept and promotes a standard user interface for all groups to access documents information and project information. This entails structuring the website information to facilitate navigation and retrieval of information.

1.9 – Thesis Methodology for Solution Development

Generally, different stages in the project require different document types. In addition, each party to a contract generates different documents than the others, in light of its role(s) in the project. Contractors, for instance, produce daily progress reports; weekly

resource utilisation logs, payment requisitions, and requests for information. Owners' consultants release detailed design plans, milestone schedules, quantity estimates, change orders, additions, omissions, and inspection certificates.

In this thesis documents are classified into four main types: 1) Transactions, 2) Proprietary, 3) Definitions, and 4) Public—see Appendix A for details of each type. Such a classification can be coupled with four possible roles (input, output, mechanism, guideline) in the project to produce something like Figure-1.3. Documents' "class-role" pairs are defined by the following parameters:

- Project stage.
- Group initiating the document.
- Frequency of issuance, like daily reports, weekly outlook schedules...etc.
- Document Format and Type.
- The Process events that gave rise to the document production
- Document's purpose in the process (e.g. declaration of intent, method statement, clauses in a contract, design update ... etc.)
- Informational role of the document in the process, as shown in Figure-1.3.
- Data or information types contained in the document (Text, Video, Audio, Spatial, Drawing, Image, Table, Schematic, Method Description...etc.).

Transactions class can be matched with various roles; for example: records of progress, reference material, agreements or guidelines, meeting resolutions, and testing results for quality control. There could be numerous views of documents and the information they might contain. A functional model is developed in this thesis and

presented in Figure-1.3 to illustrate the various roles a document might have in supporting a project management function. The modeling language used in the functional model (Figure-1.3) is the Integrated Definition symbolized by IDEFØ [IDEF 1993]. Because information is about processes, activities, and tasks that are incessantly in need for information as input and produce information as well, this information should be conveyed in documents.

1.9.1 – Modeling Document Roles in Construction Management

Standardising the format and contents of documents promotes uniformity and familiarity between users working on different platforms or systems and enhances the exportability of those documents from one organisation's system to the other without loss of content.

In this thesis each document is an Object-Type, part of one or more of the four classes (Transactions, Proprietary, Public, and Definitions). The DMID models—presented later in this thesis—depict the attributes, behaviour, and associations each document might have with the project subjects. However, some practitioners might view it as a non-critical factor that can be overlooked [Powell-Smith & Sims 1985].

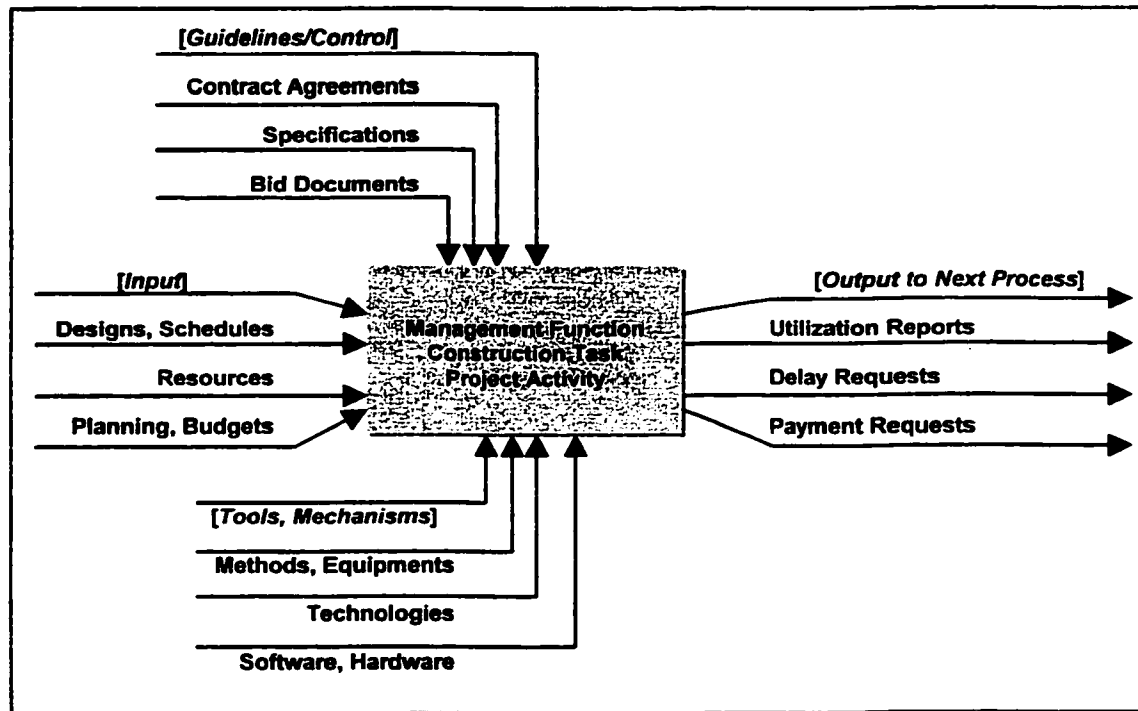

Figure-1.3: Various Functional Roles Documents have in the Construction Process

1.10 – Thesis Organization

- **Chapter 2:** Presents a literature review about the state-of-the-art in Claims research, and EDMS (Electronic Document Management Systems). It also reviews the Information Technology (IT) applications for managing the documentation in construction projects in general and for claims in particular. Also summarizes the results of structured and unstructured meetings with Claims Analysts, and project management experts who are involved in some aspects of documentation or document handling for construction projects. An identification of the major problems in documents and documentation systems are listed. Moreover, a preview of the modus operandi in document handling practices amongst claims Analysts is included.

- **Chapter 3:** Presents project management information requirements for construction documents. Evaluates the impact of document-processing requirements on the information framework, and document data models, in light of the common impact claims analysis practices.
- **Chapter 4:** Introduces the design of a model-based framework for project information exchange based on project delivery and organization. The framework models are customisable to any project structure, and that takes into consideration the distributed nature of information and project groups in construction projects.
- **Chapter 5:** Models the internal as well as the external information structures for documents in construction. External associations with other objects in the project will be part of the external data structure. These models will lay the foundation for the Document-Base or repository. The document models intend to capture the context and the rationale behind decisions affecting operations. This is achieved by encouraging project members to annotate and comment on documents when registering them with the CPDIDCenter. This results in the cross-linking of documents with relevant documents and/or events. Contexts can be gleaned from the role documents have in the process.
- **Chapter 6:** Presents a validation of the prototype CPDIDCenter website functions and components, including search and registration. This is carried out with direct access to the DMID. Search is offered in the website in various possible views or indices: subject or construction topic, association with other project subjects or information objects, claim files, and causes of potential delays or disputes, changes, contract clauses, and by special events. A hypothetical highway project case is used in the implementation



Chapter Two *Claims, Documentation, and Document Management: A Literature Review*

2.1 – Introduction

Construction claims are being reported on by researchers and outright experts involved in the management and quantification of claims. The majority of claims research, however, is concerned with proving causes, and proposing methods for quantifying delays and/or construction performance impacts. Performance Impact-analysis dominates most of the research work in this domain. Contemporaneous documents from the construction period are far more valuable to claims resolution than post-construction data compilations. However, it should not be taken for granted that project documentation is complete, or that documents always contain sufficient information to explain offsets to the baselines of the construction process or make it possible to understand the history of the project. Either case is highly improbable, especially when most project groups do not incorporate any DIS. Very little, if any, has been done in the research realm to tackle the relation between construction claims and project documentation. The notion of recreating the history of the project from documents is not new [Weiser & Morrison 1998]. What is missing however, is a way to structure the project information, link them to documents, and control those documents, store them and classify their contents for fast and accurate retrievals.

Claims research findings are being reported under three broad themes: 1) Causation, 2) Claim Analysis, & 3) Claims Management. Those themes overlap, but due to the legal nature of construction disputes, two issues are distinguished: proving facts, and the legal interpretation of those prevailing facts. The latter is beyond the scope of this research. Proving facts means establishing, based on documentary or expert evidence, the cause of the claim, and its subsequent effects. That has to be in light of the entitlement gained from the contract language. To avoid disputes, parties have to fairly allocate the risk amongst them. The contract must clearly convey the expectations of all sides, and their respective shares of risk. Owners also have to give a reasonable and a flexible interpretation of the contract conditions and/or specifications, and that begins with understanding the nature of change in a construction project, and its subsequent impacts. Rigidity in these matters can instigate disputes and litigation. Scope control is another important aspect at early stages, since it is supposed to demarcate or delineate the owner's product requirements. Scope needs continuous review by those who are running the project in order to cope with changes in site, production stage, building methods, quantities, requirements, and specifications.

2.2 – Ontology of Construction Claims

2.2.1 – Causation Studies

Causation studies focus on establishing claims' responsibilities and entitlements for impact. The types of schedules used, and the interpretations of contract clauses, may bias the reliability of any causation analysis. The quality of the documentary evidence would

affect as well. The industry made it a convention to apportion the liability for performance impacts—such as delays—amongst the project groups (e.g. owner, contractor), or to blame it on external causes (i.e. force majeure). Some outright research experts, such as [Kaming et.al 1997, Semple et.al 1994, Chan & Kumaraswamy 1997, Yogeswaran et. al 1998, Scott 1997] as well as some industry experts [De Leon et. al. 1995, Zack 1995] presented lists of potential claim causes from both a North American and international experiences.

2.2.2 – Claims Analyses

Various methods for concurrent delay analysis is presented by [Alkass et.al. 1996, Arditi & Robinson 1995] using a variety of As-Built and Adjusted As-Planned CPM schedules. The schedule delay snapshot technique is also proposed by [Revay 1988]. Labor Productivity—a critical issue in estimating impacts to performance—motivated many researchers like [Thomas et.al 1995; Ibbs 1997] to look for estimation techniques that could be used for forecasting the impact of changes on cost. Commonly an assortment of schedules is needed to evaluate the impact of changes or interruptions on time [Mazerolle 1992, Alkass et al 1996]. This assortment of schedules (e.g. as-planned, adjusted as-planned, as-built, weekly outlooks, commitment schedules...etc) can be branched into two broad categories: 1) Baselines or As-Planned, and 2) As-it-Happened or As-Built barcharts without specific sequence or logic for events. Adjustments to these basic types result from inserting delays, like EC (Excusable Compensable), NE (Non-Excusable), and EN (Excusable Non-Compensable), and then re-evaluating the project finish times. Probabilistic analysis of delays [De Leon et. al 1995] is also used to aid contractors

estimate or forecast their delays due to changes or disruptions. A study carried out by [Leonard 1987] produced regression models for the prediction of productivity losses due to Change Orders. The study, made use of data from real claim documentation, and concluded that “fine-motor” trades (i.e. electrical & mechanical) suffered more impact to their productivity due to Change Orders (C.O.s) than their counterparts of “gross-motor” (i.e. civil, architectural) trades. Cumulative effect of concurrent changes was shown to be more substantial.

Concurrent delays complicate liability apportionment analysis, and the industry relies in quantifying those delays on a set As-Planned and As-Built Schedules. However, in this thesis, As-Planned schedules are viewed as subjective at times, and their subjectivity emanate from the assumptions instilled in them. For the As-Planned schedule the assumption include:

- Normal productivity prevails in all conditions of adverse or fair weather
- Activities are sequenced in an optimized or logical fashion.
- Interruptions are exceptions to the norm (not foreseen).
- Procurement, and idle times are not accounted for as activities.
- The Process will follow the logic charted, and things will go always as planned.

As-Built schedules are created from daily reports and progress logs. Certainly, those reports are not a perfect register of project accounts especially if the format used abates crucial process information. Moreover, such reports tell what happened, but excludes the reason why things diverted into discourse. Automating the generation of

As-Built schedules would be an interesting area of research specifically for complex projects with thousands of activities. The author of this thesis recommends that electronic schedules in the next decade must be embedded with intelligent logic circuits capable of evaluating the viability of alternatives and their probabilities' of occurrence. Moreover, schedules should be regenerated or simulated directly from architectural and structural models (3-D design plans.)

In practice, claim analysts insert delays of all types: EC, NE, and EN into two types of schedules—baselines and As-builts. Those imposed adjustments are intended to study the ripple effects or impacts on the project activities, and help produce a host of schedules—known as Entitlement Schedules (commonly barcharts). They are supposed to highlight the location and period of every delay throughout the project's life. Consequently, such schedules have to present a qualified interpretation of why and who is responsible for every delay or interruption. Some schedule analysis techniques commonly used are listed herewith after. Details of such techniques are beyond the scope of this research and can be found elsewhere [Mazerolle 1992, Brunies 1988]. Some of the Delay analysis techniques commonly used are:

- Global Impact Technique.
- Net Impact Technique.
- Adjusted As-Built Technique.
- Time Impact Technique.
- Snapshot Technique.
- But-for Technique.
- Isolated Delay Technique.

For the quantification of impacts or disruptions due to changes, on construction productivity, some of the techniques commonly used and accepted by courts and arbitration are:

- Adjusted total cost method.
- Hindsight estimating.
- Differential cost method.
- Eichelay formula for OH estimation

2.2.3 – Claims Management

This field relies on the experience of practitioners and the precedents found in courts or arbitration rulings. Claims Management, as a field of study, coaches project managers and site echelons on how to identify potential claims, and how to document for them, in concordance with contract clauses [Jensen et.al 1997; Thomas et.al. 1995], in conjunction with the management of C.Os [Cox 1997], and considering both the contractors' and consultants' perspectives [Vidogah & Ndekugri 1997, 1998]. The problem can always be viewed from both perspectives', either owner or a contractor's [Jergeas 1994, Zack 1995]. Causation studies only made implicit or indirect use of documents as sources of inference. Analyses and management studies, however, relied explicitly on specific documents (e.g. schedules, daily site reports, resource utilization logs, change orders, bid estimates, contract changes, proprietary specifications, design changes...etc) to arrive at results.

Dispute resolution, another part of claims management, has long been the focus of many associations and research groups. For example, The American Arbitration Association AAA [AAA 1998] is supporting the Alternative Dispute Resolution (ADR) venue for claims settlement before litigation. In most US public contracts, the Dispute Resolution Board (DRB) requires that all disputes go through the ADR venue. Also there are the contract clauses of the Engineers Joint Contract Documents Committee (EJCDC: comprised of the American Consulting Engineers Council, American Society of Civil Engineers, and NSPE's Professional Engineers in Private Practice division). The EJCDC develops and periodically updates fair and objective standard documents that represent the latest input from construction practitioners and attorneys on the subject of contractual relations between the parties involved in a project. All of the EJCDC documents are prepared with the advice of legal counsel and reflect the experience of the practicing engineers who constitute the EJCDC.

In Canada, the ADR provisions are part of the CCDC (Canadian Construction Documentation Committee) contracts and are tested by construction practitioners with Design-Build projects [CCDC 1994, Short 1997]. Elsewhere, in a survey by [Kangari 1995], conducted jointly with the AAA, 50% of the responding construction arbitrators favored contemporaneous documents as an evidence of entitlement over real witnesses (i.e. expert's opinion). Furthermore, arbitrators complained that disputing parties deluge them with unorganized and sometimes irrelevant documentary evidence. Missing important documents was found to seriously damage some claimants' claim cases. In a

study by [Elnagar & Yates 1997], documents were evaluated to find out if they could be used as predictors or indicators of delays caused by technical or business problems.

Some of the contemporaneous documents coming from a project are: Daily Progress Reports; Meeting Minutes, Site Diaries; Drawing Logs; Correspondence; Dated Photos; As-Built Schedules; Resource Utilization Logs; Drawings And Design Changes; Non Conformance Reports NCR; External Memos From Suppliers Or Affiliates Or Lawyers; Faxes; Field Transmittal Memos. A more extensive list is available in Appendix A. Other documents, produced in the “post-construction” stages, are far less credible than contemporaneous ones. There are documents created “Pre-Construction”, such as Bid estimates; Soil Tests; Specifications; General Conditions; Contract; Permits & Licenses, and Feasibility Analysis, all of which are potential references and guidelines for construction processes. The contract agreement conditions hold special importance, however.

2.3 – Change Management

Construction work is carried out in an environment of change, in accordance with planned schedules and contract stipulations. This environment is particularly sensitive to disruptions, or risks of that sort. Such risks must be overcome and disruptions resolved quickly [RAL 87], or productivity and efficiency will be affected. There are obvious economic benefits from a smooth running project and from a prompt compensation for extras. Early resolution of C.O.s helps avert costly disputes later. Owners’ lax in issuing extensions for EN, and EC delays, can legally be construed as implicit orders for a

constructive acceleration or a constructive change. In cases of change, delay or differing site conditions the contractor must notify the client as soon as possible, and ask for instructions or clarifications to keep the work within scope and budget, otherwise delays start to clog the work pipeline. In some serious situations that need prompt action, the owner should issue preliminary notices—probably verbally—while written confirmations are processed. From a legal point of view, written notices do not necessitate production of final estimates [Schroedel 1997, Jensen et. al. 1997], given that some contractors wish to avoid hostilities with the client or for any other reason. Delayed notices would reduce or eliminate a contractor's entitlement to additional time and/or compensation, and the contractor is advised to continue delivering daily accounts of extra cost to the owner, even when its not required by contract, and ask that they be accepted as true records of activities and expenditures. If the owner objects to the contractor's entitlement, the owner can still agree on these daily accounts as an accurate statement of facts, without prejudice to the liability of the owner. As well, owners have to respond promptly to contractors' requests for instruction or clarification, or any notices of changes, delay, or differing site conditions. Given the nature of construction, owners should anticipate such requests and notices and be prepared to handle them. If the contractor is entitled to any extension or compensation, failure to grant it may later result in larger claims to compensate the contractor for the extra costs incurred in induced process accelerations. Designers may act, sometimes, as Construction Managers (CM) [Semple 1994, Jergeas 1994]. Those situations bring the issue of conflict of interest upfront. The owner must be prudent enough not to overlook cases where the CM is processing claim requests for omissions or mistakes due his/her own devise.

2.4 – Review of IT Applications for Claims

IT Implementations that are specifically designed for claims vary in their scope, objectives, and the problems they try to solve. For example, [Bubbers et. al. 1992] designed an Expert System that uses hypertext and “If-Then” rules to synthesize the causes for a claim, based on the contract clauses or language. [Alkass et.al. 1995] developed an Expert System that aids the user in identifying the types of delays (EC, EN, and NE) from a contractor's perspective. The latter system prompts the user to answer few questions before realizing a conclusion. Based on those answers, schedule analysis starts—uses the Isolated Delay Technique (IDT). In another study by [Conlin et al. 1997], a comparative analysis of various planning and scheduling software, as well as Knowledge Based Expert Systems (KBES) for claims, is presented. The study discusses potential applications of these systems for mitigating or minimizing claims, and recommends that they be part of the contract–no implementation methodology is suggested, however. A collection of scheduling utilities to automate schedule updates is used in a study by [De Leon 1995], to help owners against erroneous delay estimates by contractors. An Expert System to guide site engineers process and document C.O.s is proposed by [Diekmann et al 1992]. The system, called SuperChange, is built around the US Federal Acquisition Regulations (FAR) language, and this system is guided by an older one called DISCON by [Kraiem et. al. 88]. Elsewhere, [Abudayyeh 1996] proposed a relational data model, based on Nijssen’s Information Analysis Method (NIAM), for the acquisition, storage, and retrieval of multimedia data (e.g. Video, Audio) about delays, on a continuous/daily basis. [Vanegas et al 1993] proposed a simulation technique to forecast potential resource conflicts and time delays for the construction

project, useful when forecasting the impact of C.O.s. A summary of those studies is presented in Table-2.1.

The reviewed systems have focused more on helping project echelons identify causes and/or analyze delays. Little is proposed as to how solve the key problem of classifying documents' information and storing them. In general the solutions surveyed assume that documents are readily available, and information is sufficient for all involved in the analysis work to find the delay or disruption causes, and be able to estimate their impacts.

Most of the reviewed studies point to the fact that it is not a rare occurrence to find a project with fallible documentation, which eventually impedes proper claims analysis. Other management activities can substantially be affected by the truncated and incomplete process documentation. Activities such as cost estimating, scheduling, site management, planning...etc, all survive on data permutations among themselves, which takes the shape of document transactions. The literature, in the most part, deals with the documentation problem with commonality and ubiquitous vagueness, and no solution was proposed to solve some of the ingrained problems that construction documents suffer from in format, distribution, storage, retrieval, and contextual capture of process information. In a report by [Boughton et.al. 1997], the government of Hong Kong forced the West Kowloon Expressway project (US \$300 million) participants to implement a Project-Information-Management-Systems (PIMS) in anticipation of disputes. Implementation faced much resistance from contractors and designers, and many

documents were never captured electronically—especially drawings and design changes [Archer et. al. 1997]. Nevertheless, this is a pragmatic approach, which explicitly deals with documentation in anticipation of claims.

Table-2.1: Review of some IT Applications from Construction Claims Research

Author	System	Name	Caution	Analysis	Management	Comments
Abudayyeh 1996	Database			X		Models delays' information using Nijssen's NIAM Relational language; uses multimedia.
Alkass et.al. 1995	Expert	CDCA	X	X		Isolated Delay Technique IDT for Delay Analysis
Boughton et.al. 1997, Archer et. al. 1997	Information	PIMS's	X	X	X	Document-Oriented; used in Anticipation of Claims
Bubbers & Christian 1992	Expert		X			Hypertext Applications for cross linking related clauses
Conlin & Retik 1997	KBES		X	X	X	Comparative Study of Knowledge-Based Expert Systems
Diekmann & Kim 1992	Expert	Super Change			X	Based on the US Federal Acquisition Regulations (FAR) Contracts for Management of Change Orders
Kraiem & Diekmann 1988	Expert	DISCON			X	Claims Management
De Leon 1995	Application Utility	Schedule Review Utility		X	X	Collection of schedule management utilities for Delay forecasting and Claims Management.
Vanegas & Halpin 1993	Simulation	Micro-CYCLONE		X		Schedule Simulation and Sensitivity Analyses

Some interesting statistics out of that project: 684 claims, 33,000 registered documents, and 2000 change/variation orders. Some of the problems that hindered the PIMS full-scale implementation include:

- 1). The developers of the PIMS never implemented an information architecture or document data-models to represent information from project processes.
- 2). Most participants did not connect to the PIMS network due to reasons of pessimism about the intentions of the system, or because they did not have the IT capabilities to do so.
- 3). Participants had to go through a formidable learning curve because there wasn't a warm up period before the project, and many groups had to join in a short notice while activities at site were well underway.
- 4). Audit-trails to track documents were never fully deployed.

2.5 – Claims Modus Operandi and the Burden of Proof

Project groups have to retain relevant construction documents, normally produced from construction processes (Contemporaneous) in order to establish their entitlements and proofs of impact. However, since many contractors do not use any Document Management Systems (DMS)—Electronic or otherwise—to control the project transactions, transmittals and contracts, this consequently obviates the claims analysts' work to a large extent. Document management, using DMSs, is a conceivable and feasible alternative to ad-hoc filing systems, because important information about context and rationale is captured as well. Table-2.2 presents a description of what context and rationale might be.

Table-2.2: Defining Context and Rationale for Document Creation and Management

Context should define	Rationale should define
What is being constructed, and the processes or special methods involved?	Based on which design update or revision, or addition or change?
When this task will take or already took place?	Why things happened the way they did?
Who is supervising; doing; or supporting tasks?	Major decisions, by whom, what is the intent from the course chosen?
Where this task is taking place, and in which Workpackage (WP)?	At which stage of work, and during which process decisions were taken?
What instigated the change, and were there any alternatives, if any?	What was the trail of events leading to the current status?
Referenced Specifications or Condition Clauses?	What are the implementation circumstances like weather or strikes?
Based on which design update or revision?	Major decisions, by whom, what is the intent from the course chosen?
What instigated the change, if any?	Which alternatives were considered then before making the decision?

The use of commercial DMSs in itself does not guarantee that contextual process information or decision rationales are captured. Nevertheless, with proper document indexing and subject indexing, the EDMSS project users will have a robust tool for tracking, storing, and exchanging documents. Also to control issues like:

- 1). Content management
- 2). Collaboration and authoring
- 3). Review and annotations
- 4). Publishing
- 5). Distribution
- 6). Storage and retrieval
- 7). Vaulting and deletion rules

2.6 – Review of Document Management Solutions for the Construction Industry

Most of the research in model-based EDMS (Electronic Document Management Systems) is fairly recent, and largely influenced by the new advents in IT. Electronic Document Management EDM is a subset of the IS, flourishes on the network and mainly it is composed of:

- Platforms of formatted documents
- Links to the repositories that hold construction process information
- Workflow rules based on claims documentation requirements.
- Control of access and editing privileges
- Document-Base or a Document repository
- Definition for the organizational Roles in the project

Some researchers consider EDMSs for the management of knowledge and organizational memories (Shum 1998, & Kappes et. al 1998), while others still confine it to the distribution and storage of black boxes of objects without exposing the internal information structures of those objects. Meta-file information for describing the information content of any document, is one of the implementations of the black-box paradigm. Such Meta information is considered a lightweight version of the document's contents, and the contexts or processes such documents are trying to describe. Meta Information can be kept as text in databases, and is also easily transmitted and parsed by compute programs working on any Operating Systems (OS).

In a study by [Bjoerk 1994], documents Meta-information was represented or modeled using STEP's (Standard for Exchange of Product Data Information) EXPRESS-G modeling language, and only Meta-information (e.g. title, date, from, to, subject, header, footer, equation...etc.) are classified. This means that documents are treated as black boxes, and their contents classified based on descriptive (Meta) models. Contents are not explicitly cross-referenced to other information entities in the system, however.

Another approach proposed by [Rezgui & Debras 1995] called the DOCCIME project, intended to generate documents via a construction project data model. In their attempt they have created two models, the first model is called the Document Reference Model from which various document types are derived. This reference model concentrated on CCTP (Cahier des Clauses Techniques Particulieres) a French standard or the French full specification document. The second model is a Construction Project Reference Model. Both models use the STEP EXPRESS modeling language and Relational Modeling to represent the document data models—although at times those models seemed to follow the NIAM's notations. Ultimately, an association model ties both document and project models. This approach is intended for the project life cycle, from inception to decommissioning. However, this system is complicated and masks the project model from the document. Also, extensive mapping is needed in order to match documents with pertinent project object instances. This means that the project information model definition is separate from the documents', and documents are just by-products of the process.

Bjoerk worked also with the CONDOR project [Rezgui et.al. 1998]—part of the EC (European Community) ESPRIT research project. The CONDOR approach uses the UML [Booch et al 1998] semantics and language instead of STEP's EXPRESS-G notation for modeling project information. CONDOR implements the same Meta-Document Information Model approach of [Bjoerk et. al. 1994]. However, for CAD documents, CONDOR created a Meta-information instance, which allows each layer of the CAD file to be assigned to a different Actor. CONDOR targeted construction consortiums that commonly partner together when bidding for new work, meanwhile wanting to promote their existing legacy systems instead of developing new EDMS solutions. The CONDOR information system addressed two problems, compatibility between participants' EDMS systems, and distribution of information objects. The CONDOR is an initiative made to link construction's big players in Europe, and to enhance exchange of knowledge and business information amongst them. CONDOR has four models: 1) the CIMM (construction information management model) to describe how the information is organized in the system, 2) Generic Document Model for semantic linking between various forms of construction information, 3) Written Document Interpreted Model for document content structure and 4) CAD Interpreted model for interpreting CAD drawings.

[Froese et al. 1996] reported on a research at UBC (University of British Columbia) that was set to develop a Project Management Information Control System (PMICS) database to manage, amongst other things, documents. The system focuses on project file transactions as they progress through the project. The system is meant to record only transactions, contents are not computerized, however. The model underlying

the system explicitly lists 13 transaction logs to be tracked (e.g. material storage logs, RFI logs, C.O. logs, Progress reports...etc.), and links them to participants and Work Sections. Work Sections are used by [ISO 1993: standard ISO TC59/SC13] to define Workpackages or building elements. This standard relates building elements to their functional use, and spatial properties. The project model uses the EXPRESS-G notation. Elsewhere, in an attempt to apply Core Process models for contract and Document Management, [Froese 1995] built a model based on the Building Construction Core Model [BCCM 1994] and used entities like Participants, Workpackages, and Documents. The model tries to match BCCM entities, but draws a loose definition of Workpackages, Participants, and Documents. For example, Workpackages can be cost items, components, or systems in the project. This approach handles documents as black boxes recording only their movement.

Elsewhere, as part of the COMMIT project in the UK, [Brown et. al. 1996] developed the COMMIT Information Management Model (CIMM). The COMMIT project works also on integrating construction project information using some process models as common denominators. CORBA's distributed Object Services and Facilities are the technological vehicle to bring about COMMIT's objectives of integration. CIMM has two sub-models: Rights/Authority to information model, and a Notification/Status model. CORBA standard was seen as the new phase in distributed computing. That outlook didn't stand long enough before new Internet consortiums of software and web organizations started promoting more flexible standards like SOAP (Simple Object Access Protocol) and XML (eXtended Markup Language), which works with existing

internet infrastructure like HTTP/IP (Hyper Text Transfer Protocol/Internet Protocol) for web content, and POP3/SMTP/HTTP email standards with the S/MIME standard for security (www.w3.org).

2.7 – Document Associations with Project Information

To assist project members, and claim analysts retrieve relevant documents, it is essential to associate documents with indexed or structured project information topics. In a related work, the notion of Project-Memory [Weiser & Morrison. 1998] is used to describe the process of reconstructing project histories, and rediscovering the rationale that accompanied certain decisions, or changes using documents. As part of that work, an Object Oriented (O-O) model was set-up for business meetings to document, in a relational database, the rationale and context surrounding each decision. The work had an experimental part that showed that when documents are clearly cross-referenced, the tendency by those who are not familiar with the problems of the project, to comprehend the issues at hand, increases. Others, like [Shum 1998], experimented with reconstructing organizational electronic memories. Visual tools or display systems are used as well [Conklin 1999] to capture the key issues and ideas during meetings and create shared understanding amongst a team. That work by [Conklin 1999] briefly describes how a display system (QuestMap[®] by www.softbicycle.com), which uses hypertext, captures the group members' thinking and learning especially in large complex projects. It identifies two types of knowledge: 1) formal like books, manuals, documents, training courses, reports, white papers, plans, spreadsheets, designs, memos, etc. and 2) Informal. Informal knowledge is created and used in the process of creating the formal

results, and includes ideas, facts, assumptions, meanings, questions, decisions, guesses, stories, and points of view. Formal knowledge can be construed as context, while the informal part can be a decision rationale. .

The surveyed EDMS solutions have shown some shortcomings, they include:

- 1). Project information and properties are not represented consistently in their formulation.
- 2). Specific or peculiar contractual relations are not accommodated by the systems presented.
- 3). Documents are not commonly linked to both project information or contract management requirements.

2.8 – Review of Web-based Collaboration Research

Research in construction documents' content and context management is fairly recent, and largely influenced by the new advents in web technology and online collaboration models. For example: OSMOS (Open System for Inter-enterprise Information Management in Dynamic Virtual Environments) [Rezgui et. al. 2000] is an ongoing research that seeks to develop construction virtual enterprises for group work. It requires specific semantic models, and OSMOS-specific API (Application Protocol Interface). The API should work in hand with a set of information repositories, toolkits and plug-ins that allow commercial and proprietary systems to participate in the OSMOS virtual enterprise. One of its other objectives is to develop model-based environments for tracking, and managing the release of, and access to, any shared information (including

documents). Another initiative, the ToCEE (Towards Concurrent Engineering Environment) [ToCEE 1999] project is set out to facilitate information exchange in support of a concurrent engineering environment. ToCEE would include documentation on briefing, design assumptions, progress records, specifications, etc. However, it has narrowly modeled information about the project teams, products, documents, and activities. ToCEE research group identified the enormous administration costs associated with document handling, and sought to establish a document audit system to keep track of document version numbers, and document interrelationships. However, the scope and layout of documents are to be determined by practice and standards, which differ from project to project and country to country.

2.9 – Benefits of a Web-based Project Document Center

The Internet presents a technological plane field for all project groups, affording them, almost seamless, online access to documents and unstructured information. It offers an attainable medium—in terms of technology and cost—for publishing and exchanging documents with short learning curves for users. More than ever, the Internet is becoming the backbone for augmented and geographically spread set of partners collaborating together. Modern internet servers and team-work portals are being continuously unleashed to support critical requirements, like: customized content management, concurrent enterprising, access to large corporate data sources, collaborative engineering, and virtual project enterprises or centers. Facing an increasing complexity of product development along with an intensifying market competition, the Virtual Enterprise (VE) appears nowadays as a necessity within nearly all industrial fields

[Hardwick et. al. 1997]. Partners who are smaller, changeable, distributed, and who are forced to collaborate despite their heterogeneous computer platforms characterize construction project organizations. VEs provide the ability to carry out project management processes seamlessly and to capture, access and assess the state of the project in real time, and that depends on a combination of [Zarli et. al. 1999]:

- Scalability
- Open Infrastructure & Location-independent access
- Enterprise Information access for seamless capture of a project's state.
- Security and Transactional Support.
- Access to distributed legacy databases and information systems

Therefore, the Internet is an excellent communication and information relay platform especially with new standards for distributed applications and Web-based project data repositories are coming to light and supporting more than ever new ways to run and control construction projects.

2.9.1 – Review of Web-Based Project Document Management Systems

Web-based document management is still experimental, and propelled mainly by software developers as part of their strategy to extend the shelf life of their legacy applications. Web-based solutions vary in purpose and clients, and they include:

- 1). Messaging and electronic mail management.
- 2). Business-to-Business (B2B) portals.

- 3). Team collaboration portals.
- 4). Web-based workflow, and automated document delivery.
- 5). Content management
- 6). Electronic form processing.
- 7). Project management services like calendars, tasking, issues, and discussion groups.

The surveyed commercial solutions presented a crossover between project planning/scheduling environments and specific document content management or collaboration workflows. In general they can be classified into seven categories. Specific offerings of concern are Expedition[®] (www.primavera.com): a contract administration and contact management application. It has a built-in database, and works for a single group or single enterprise. It also uses a fixed hierarchical relational model for Meta information. Domino.Doc[®] (www.lotusnotes.com): built on Domino's proprietary document management platform, and can be used for tasks like checking collaboratively written documents. However, to integrate with Domino, users of non-compliant desktop applications generally won't work directly with Domino.Doc but rather will access documents from desktop applications that have been integrated with it. Retrieval Ware[®] (www.excalib.com): uses pattern recognition and natural language processing, incorporating syntax, and sentence morphology to search diverse data libraries and lexical sources for knowledge based on a profile by the user. Used for fuzzy searches where the data is not structured, and users need to train the search engine. icXpert Vault[®] (www.icomxpress.com): keeps documents in content servers, which are accessed by property servers that should hold Meta data about the documents. Users can

customize the structure of their document vaults, and it allows for document deletion based on a policy manual that is triggered automatically. iTeam® (www.documentum.com): provides a project space for cross-functional team collaboration on the web, with preset sections for discussions and deliverables (task assignments). It's up to the teams, however, to decide how to organize documents.

When implementing those commercial web-based information management solutions, certain limitations have been noticed from a project documentation perspective:

- 1). Systems are proprietary and expensive to license. Pricing depends on the level of integration, and whether the application includes a database, and a search engine.
- 2). They implement Domain-Specific proprietary data models for all businesses and industries. Business rules used in the design of the databases are not explicit, and database models are not open for manipulation.
- 3). More focus is on the workflow aspect of document creation, than the information categorization or document cross-referencing to construction information.
- 4). Reconstruction of project events (trail audits) is limited because of the lack of cross-referencing of documents to project objects, events, or contract clauses.
- 5). Document Meta models—if existent—are fixed (rigid). By contrast, the solution that will be presented in this research (the CPDIDCenter) explicitly solicits information from users to link documents to project subjects, people, contracts, claim causes, damages/impacts, events, sites, changes, problems, and other hosts of construction topics/subjects relevant to a construction delivery.

- 6). The issue of varying construction delivery methods and project organizations is not addressed or incorporated in the communication infrastructure (i.e. servers, databases...etc. Their biggest limitation is that they are using a “One-Size fits all” policy.

2.10 – Review of available Commercial Document Control Tools

Few tools, which are designed for corporate or business use with scalable capabilities based on the customer’s needs, are commercially available. The market distribution, shown in Figure-2.1, indicates that almost 25% of the sales went to document-centric industries, such as insurance, health care, and governmental services. The highest number of sales was in Process industries. With few exceptions, all the surveyed EDMSs serve mainly vertical industries such as insurance, health care, and banking. Limited information, if any, is found about the use of commercially or in-house developed EDMSs. In those few cases, an EDMS is used mainly for contract administration, cost accounting, or for managing changes to CAD drawings.

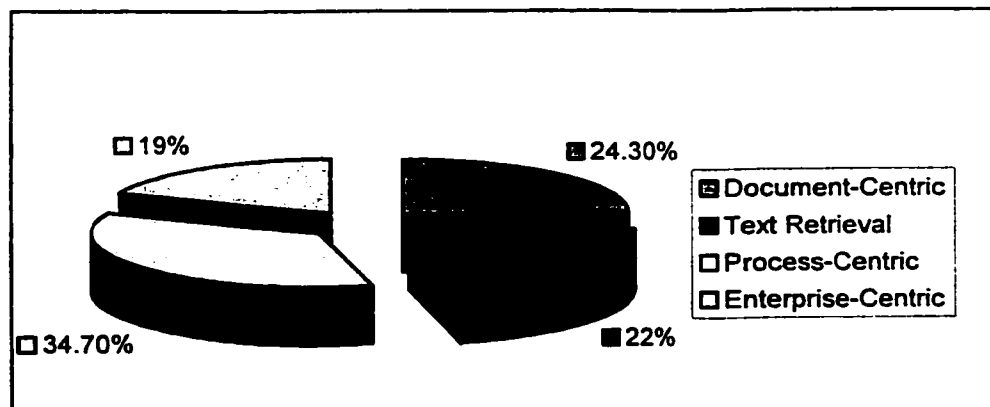

Figure-2.1: EDMS Market Shares By Functionality in the US for 1998. Source: KMWorld February 1999

In general, commercial EDMSS embrace peripheral support for Optical Character Recognition (OCR) of scanned documents. Scanning transfers document images to electronic data, that could be searched, and in the most part, such systems are for documents that do not come in standard formats. Their biggest target is the knowledge intensive market, like health care, pharmaceuticals, manufacturing, and insurance. They excel on certain fronts, while falling back on others, and some of their shortcomings include:

- Databases are proprietary, with hidden schemas, and unpublicized assumptions.
- Information structures not easily scalable to construction needs.
- Automation of document processing tasks is the focal point.
- Documents are viewed as icons or black boxes kept in their native file formats
- Documents' descriptions rely on run-time Meta Models.
- Cross-referencing is primitive, linking documents to each other, sometimes without regard to their content.
- Some EDMSS do not use databases of their own; instead, they rely on one provided by the hosting system.

It is interesting to know that there are specialized EDMSS for multimedia-based information, like graphics, images, CAD, Video, and audio. In many cases a commercial EDMS would chart the user's system hard drives and digital warehouses, and maintain pointers to other document sources on the Internet.

2.11 – Documentation Problems: Recap of the State of the Art.

Claims analysis is an art more than a science; hence the subjectivity experts have to contend with every time they set to analyze a claim and prove entitlements to damages. The costs of compiling suitable information (i.e. documents) for claims is high indeed, and that is due in part to the large amounts of time spent searching and retrieving documents. Ensuring a fair and an equitable adjustment to performance impact costs is dependent on four elements: 1) Proving the cause and liability, 2) Proving entitlements, 3) Calculating the damages, and 4) Defending the claim. The first two parts are not possible without contemporaneous documentation of project events. Documentation is a vital function in construction contract management. Inadequately organized documentation, or documents of inferior quality will adversely influence the strength of any claim case. Effective documentation is accomplished through simple guidelines and organizational discipline. The organizational discipline needed for effective documentation requires formalizing claims' management and documentation requirements in the form of rules for control of document issuance, distribution, and storage. Some guidelines are commonly part of every contract in the change and claim management sections. If documentation is a personal initiative by site echelons, then some projects may have excellent records, but others, surely, will not. The web offers a plane field for all project groups and allows seamless and cheap connectivity to enterprise data stores and documents regardless of the systems project groups use. Some web-based solutions, and knowledge management initiatives were reviewed and commented on.

Some records that are essential in supporting claims are:

- Original estimates and their underlying assumptions.
- Correspondence throughout the life of the project (including the bidding stage).
- Contract forms including agreements, bidding invitations, bid quotations, specifications, and conditions.
- Minutes of Meetings, and letters of understanding.
- Daily and periodic progress reports and Payroll logs.
- Photographs and Videos of site progress.
- Analysis and design sheets, engineering calculations and working drawings.
- Quality control/ assurance records.
- Schedules and other planning documents.
- Procurement records for labor, equipment, material, and services.



Chapter Three *Analysis and Modeling of Construction Project Document Information*

3.1 – Introduction

The documentation methods used by the construction industry do not benefit from the current advancements in IT such as the new distributed programming, and Online Active Processing (OLAP) capabilities that allow a remote client to query or send document forms using an Internet Browser. Databases are now accessible over the Internet and it's easier than ever to change the logical schema of a database (i.e. change table structure, field specifications, or table relationships), insert data into records, or monitor ongoing functions. Earlier, this research promoted a document instance to an object with attributes, and behavior defined by the operations that can run on it. The data contents of a document can have a logical structure that is represent-able using a technology such as XML (eXtended Markup Language) schemas. A document's content can be represented by a logical structure to define the relation between the different data sources that make up that document, and delimits its relation to other project information subjects. Documents' contents are drawn in from various information sources, such as: project process or operations, claims, contracts, changes, people, and events. Some data that should be routinely included in every document are: WBS, Cost Account, workflow

or claim processing instructions, references to relevant contract clauses or specifications, and activities. Hence, in this thesis every document is associated with as many information objects from the project organization as feasibly possible in order to distinguish each document and bring about more contextual information about any claim event, with the rationale behind key decisions affecting the performance of activities.

3.2 – Examples of Claims Documentation

Learning from claim anecdotes assists contract administrators understand the significance of events and their contiguous documentation. Project groups, collectively, complete the picture about the history of the operations, and contribute to the construction events and their documentation. Any document, created for or from a construction process, represents a state in time (i.e. a time capsule), describing a particular event. Events, in turn, are consequential and have other events preceding or following them. An event is a state in the project operation that can take the shape of a milestone, failure, stoppage, labor strike, major change, or even a cause of impact. Insofar, this research capitalizes on this understanding, and considers the document as an object, capable of having behavior, attributes, and roles. The following anecdotes are summaries of sample cases that have been reviewed for documentary and information contents. The focus here is on the “Paper-Trail”, with interest in relations that might exist between documents and events; for example: causes, damages, baselines, time of occurrence, contract stipulations, responsibilities, project organization, duty to report, document workflow, document types/titles...etc. The reader will find that highlighted phrases/words are “document (able)” events, or documents, or statements of facts.

3.2.1 – Anecdote 1: Owner is the Construction Manager and Engineer

Owner ^(Role) delivers a Milestone Schedule ^(Document) to the contractor ^(Role). Both sides either agree on it without alterations ^(Baseline Documents) or either side can request a change ^(Meeting). The Milestone Schedule ^(Document) guides the contractor to the Delivery Dates ^(Statement). The owner is liable ^(Clause) for any delays ^(Cause/Event) in delivering ^(Time) the working drawings and plans ^(Document) to the contractor on time ^(Contract Commitment).

3.2.2 – Anecdote 2: Consultant is the CM in a multi-stage project

Architect ^(Role) contracts ^(Document) with subcontractors to carry out the work in a multistage fast-track project. The Architect is responsible by an agency contract ^(Role), with the owner, to manage ^(Role) and direct operations according to specifications ^(Document), and budget requirements. Programming ^(Document) the entry of each trade to the project is, thus, the responsibility ^(Contract Commitment) of the Architect, and he has to guard against conflicts or trades over-crossing or disrupting each other ^(Cause/Impact). Loss of productivity ^(Impact/Effect), for contractor's crews, due to disruption or stoppages may lead to delays ^(Impact/Effect) in the delivery ^(Contract Commitment) of that segment of the work ^(Contract/PCWBS), and eventually the Architect will have to reprogram ^(Cause/Effect/Document) the work again.

3.2.3 – Anecdote 3: Changed Conditions in a Stipulated-Price Contract.

The Contractor ^(Role) while cutting ^(PCWBS) through a hillside for a highway project ^(Work Package) hits huge lumps of metamorphic hard rock deposits ^(Event/Cause). Referring to the tender documents for soil tests ^(Document) supplied by the owner ^(Role) in the bid

invitation ^(Document), finds that particular strip of the road has been delineated as sedimentary rock deposits ^(Fact, Potential Liability) with Silica-Cemented shale. The differences ^(EC delay) in the method of cutting and time required are enormous for that strip. The contract ^(Rules, Guideline, Document), which is for traditional Lump-Sum ^(Contract Type) works, is filled with exculpatory language ^(Clauses) that exonerates the owner of any liability for changes in soil conditions. The contractor, through meetings ^(Documented Event) with the owner, learned that the owner and his consultant had superior knowledge ^(Fact, Liability) of the site, since they spent a year exploring ^(Fact) the site before inviting bids. The contractor files a claim ^(Document) with the owner requesting remuneration for the direct and indirect costs of the unexpected change in conditions ^(Impact/Effect), and reserves his right for future impact costs, and any delay ^(Impact/Effect) extensions. The impact may include labor lost productivity ^(Impact/Effect), and extended overheads ^(Impact/Effect) for the delays.

3.2.4 – Anecdote 4: Owner Responsible for Design Information

The owner ^(Role), in a phased project is responsible for ^(Liability) supplying the contractor ^(Role) with design information in the form of plans and working drawings ^(Document). The agreement ^(Contract) between the owner and the contractor, due to a lapse in the owner's judgment, gives the contractor ^(Clause) the freedom to schedule operations ^(Document), and tasks at its own pace. The owner's architect ^(Role), during one of the stages ^(Schedule, Project Commitment WBS), could not keep up with the contractor's self-proclaimed schedule ^(Document), and was overwhelmed by a barrage of requests ^(Document) to release pertinent drawings ^(Document). The architect submits the drawings ^(Document), but to the owner's dismay, 22 days later than planned ^(Cause). The contractor sends out requests for

an extension ^(Document) and reserves his right ^(Clause) for impact, and against liquidated damages ^(Clause). The owner's reply was lax, and lapsed beyond the contract reply period ^(Clause/Cause). The contractor understood the owner's silence as an implied request ^(Clause/Cause) for a constructive acceleration ^(Cause/Impact). After completion ^(Event, Document) the contractor claims ^(Document) for acceleration costs, for extra resources, and the loss of productivity ^(Causes/Impacts), on the basis ^(Clause/Entitlement) of a But-for schedule ^(As-Built) analysis, and the fact that: but for the owner's implied rejection of extension ^(Event/Cause), acceleration costs would not have happened. The contractor is also claiming for the equivalent of a delay's extended overhead ^(Impact, Cause, Damage).

3.2.5 – Anecdote 5: Owner Disrupts Work Through a Faulty Change Order

An owner ^(Role) sends a Request For Proposal RFP ^(Document) for a contemplated change ^(Cause/Cause) to the hot water piping system ^(PCWBS). The new scheme ^(Document) calls for a bigger diameter with changes to outlets, boiler connections, pumps, and faucets. The contractor analyzed the changes ^(Document) and realized some contradictions in the detailing ^(Cause) provided with the drawings ^(Documents). Thereafter, the contractor requested interpretation ^(Document) of changes and Information on how to proceed ^(Document), from the owner's consultant. The consultant did not reply promptly ^(Clause/Cause), and the contractor, facing such uncertainty, shifted his operations ^(Impact) to other sections ^(PCWBS) in the project. Three weeks later ^(Clause/Cause) the new designs ^(Document) arrived. The contractor could not re-assemble ^(Event, Cause) his crews before a week ^(Event). When the contractor's crews were ready ^(Event), some connections did not work ^(Cause), and the owner-supplied material ^(Contract) was off-specs ^(Specifications). The contractor finally commences ^(Event) and it

took him another week ^(Event) to gain normal production ^(Baseline, Cause, Event). The contractor submitted a request ^(Document) for a time extension, and a claim ^(Clause/Document) for the impact of changes. The damages included ^(Impact): disruptions to normal progress ^(Baseline Document), deterioration of productivity and efficiency ^(Baseline Document, Resource Logs), out-of-order sequencing which entailed re-staffing ^(Impact) and extended overheads ^{(Impact, Damages) Logs} because of delays.

3.3 – Formalising Documentation Through Business Rules

A Rule is a statement that defines or constrains some aspects of the business. This might be a term or a fact (structural assertion), a constraint (action assertion), or a derivation [Hay & Healy 1997]. It is Atomic in that it cannot be broken down or decomposed further into more detailed business rules. A Business Rule Statement is a declarative statement of a structure or a constraint, which the business places upon itself or has been placed upon it. Facts, constraints, and derivations of rules are deduced from the contract clauses pertinent to claims and relevant “quantum-meruit” or adjustment language. It pertains to the operational constraints, changes, and disruption facts or events. Therefore, the concern is what data may be recorded in the information system. The facts of the cause of the impact can be viewed from different perspectives according to the stakeholders. The data collected to prove a cause or an impact must cover: process, location, people roles, timing, damages, change motivation and alternatives considered. The purpose is to make documenting facts tractable. It is possible to model business rules as constraints on data. It will be much more difficult to make equally clear assertions about business rules the way they are practiced in construction claims

management. Derivation of rules from facts can be documented as relationships, attributes, or generalization models. Examples of a documentation workflow amongst groups' management functions are modeled using DFD, as shown in Figure-3.1. It is also possible to model such flows using the Integrated Definition (IDEFØ) [Hanrahan 1998] for system and functional dependency modeling [Hammad & Alkass 2000-a]. The workflow development is beyond the scope of this research; however, business rules for documentation will be incorporated in the design of the DMID as part of the CPDICenter. Research into DFDs for construction projects is very limited, and it is interesting to find a whole PhD thesis dedicated to data flow identification to support project automation/integration and productivity this issue [Abou-Zeid 1993].

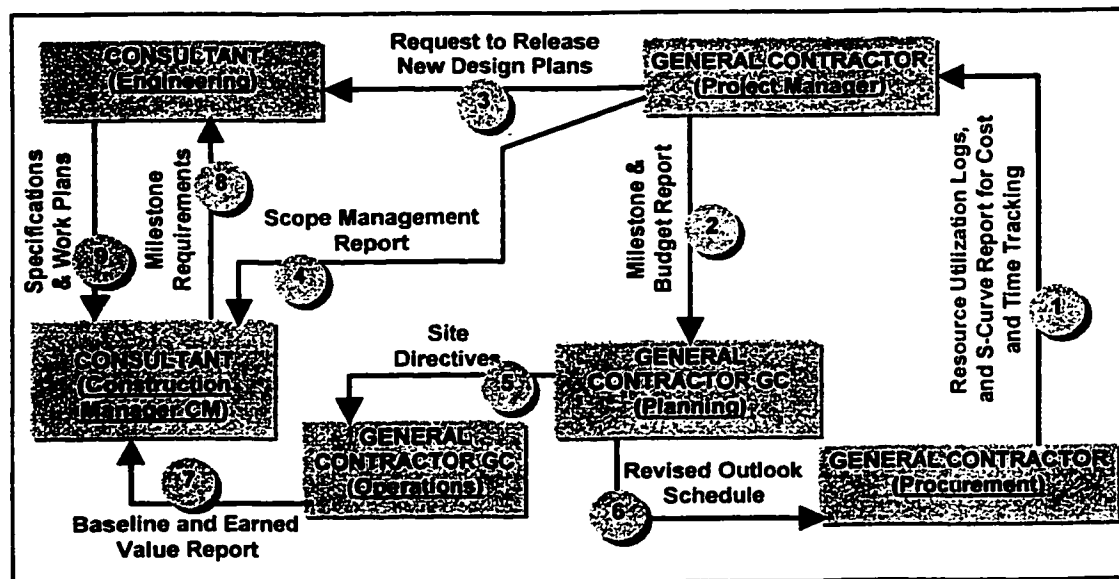

Figure-3.1: Example Document Flows Amongst Project Management Functions.

3.3.1 – Sources of Claims' Business Rules

Documentation rules are customary in most contract agreements, bid invitations, conditions of contract, or requests for proposals, and they pertain to, or exist as:

- Qualifying statements.
- Exceptions, or Exclusions.
- Conflicts or contradictions.
- Limitations on time, budget, or quality.
- Change order procedures and documentation requirements.
- Work stoppages or terminations.
- Inspections, certifications, and release of payments.
- Handling of Requests of Information.
- Scope definitions.

Scope is traditionally found in specifications, drawings, methods, conditions, budgets, material specifications, statements by owner...etc. Exceptions, for example, are found in clauses for differing site conditions, quantity changes, or material shortages. Qualifying statements can be contingency plans, allowances, and design review processes. Some organizations like NASA implemented document management procedures [NASA (1997-a), NASA (1997-b)] based on the ISO 9000 recommendations. They are called NASA Centerwide Work directives and quality recommendations. Those directives formalized, amongst many things, the creation and handling of its internal as well as external contract documents, contract changes, source evaluation, design control, control of non-conformance, and unsolicited proposals and any subcontractors working

on its space programs. Such regulations lay a working ground for construction organizations to implement in their future design of document-processing instructions. An ISO 9000 interpretation for construction projects is presented by [Nee 1996], with a focus on the implementation of Internal Quality Audit checklists. Documentation and Document Management are parts of the ISO 9000 quality system approach.

3.3.2 – Business Rules Examples for Claims Documentation

Such procedures or rules are possible and may be favoured or dictated by a contract clause or industry custom. For example, an owner while sending a Request For Proposal (RFP) to the contractor should try to add more contexts to the document transaction or flow by including following information:

1. Size and character of extra work (drawings).
2. Technical specifications (new, update, revision, old).
3. Budget breakdown (provisions of payment).
4. Schedule (new, old, milestones).
5. Time for the contractor to establish a price
6. Performance requirements (specifications, conditions).

Another example involves an owner replying to a contractor's request for an interpretation of contemplated changes. The owner can include information like:

1. Scope of change.
2. Old conditions or specifications and their replacements.

3. Old drawings, and the new ones.
4. Budgetary information.
5. Quantity of change.
6. Methods, if specific operations dictate specific techniques.
7. Contract clauses giving the owner the right to change, and liability for impact.
8. Possible supplier of the new materials, equipment, labour...etc.
9. Schedule of document deliverables
10. What the contractor should do after receiving this letter.
11. Reference detailed engineering drawings, codes, or schematics.

3.4 – Recreating Document Trails: Sequence Diagrams

Sequence diagrams, like the one developed in this thesis and shown in Figure-3.2 utilizing the UML [Booch et al 1999] notation, are beneficial tools to establish a stepwise workflow for documents, or to recreate paper trails. Such diagrams will show time-dependent correspondence or document transmittals amongst project group for a particular claim or change or problem. The purpose is to relate documents to issues, groups, time, and the context of the problem or production event at hand. For an explanation of all modeling languages' notations and constructs used in this thesis see Appendix B.

The piping problem demonstrated in Figure-3.2 depicts the sub-contractor as trying to relay to the main contractor and consultants for solution. The new solution induced new changes to material or method, which in turn required the contractor to evaluate the impact on his schedule and cost and eventually request an extension. Having received a partial extension, the main contractor informed the consultant of his intention to accelerate. Hence, the documents pertaining to this case should be cross-referenced for future retrievals.

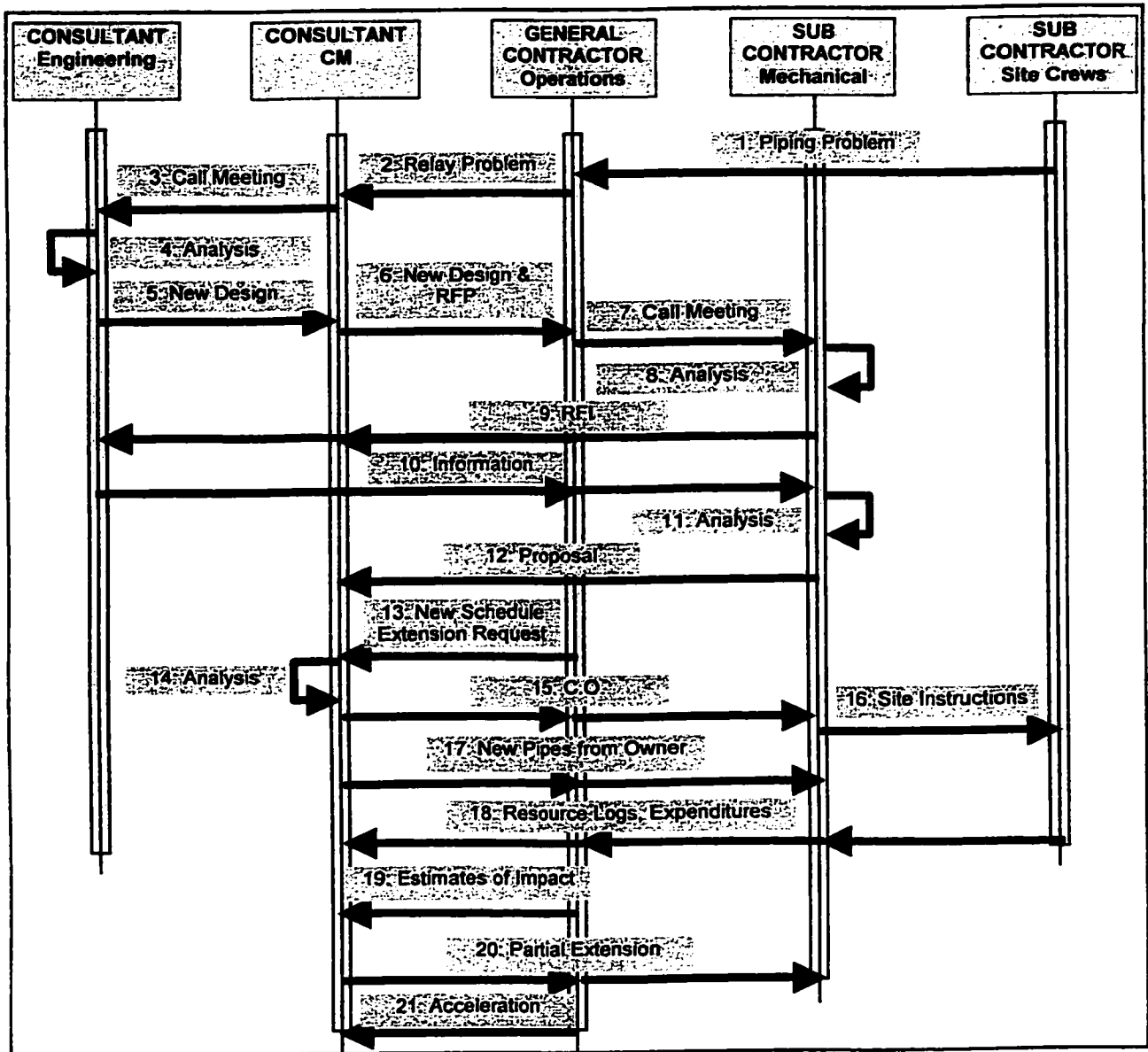

Figure-3.2: Sequence Diagram Showing Documents generated for a Piping problem

Sequence diagrams are visually appealing, informative, and show, in a chronological order, documents' flows amongst groups' management functions. Sequence diagrams also present snap shots of the documentation that ensued because of a site problem or a claim [Hammad & Alkass 1999-b]. Flows can resemble information, abstract data, phone calls, meetings, directives, status...etc. The vertical lines should represent functional entities in the project (e.g. groups' Management Processes), or offices. The DMID logical and conceptual design, in conjunction with logical views of

static and dynamic documents' class object models, will benefit from the realizations found in sequence diagrams.

3.4.1 – Example: Reconstructing documentation for a Piping Problem

The following example charts the history of a piping design problem that was previously described in the anecdotes synthesis section. Documents generated are modeled using sequence diagrams, as shown in Figure-3.2, and enumerated in a chronological order according to their actual sequence.

Further explicit associations between documents and things like the work area, dates, or type of issue will rationalize the logical relations and should aid web search engines classify documents. Search engines can work in the background (using web-bots) based on keywords, concepts, and topic hierarchies, bring them back to the user, and suggest more documents according to user responses and weighting of documents. The sequence can be reconstructed with claims documentation rules in mind. Ultimately the reconstruction of claim documentation is better served if a special search engine (trained on claim rules, and document information patterns) is in place, and all documents are scanned, classified and registered with it. This research has classified the documentation associated with claims, and developed a system framework (i.e. the CPDIDCenter) to capture and streamline all documents registration in the project. The CPDIDCenter DMID is designed to capture as much Meta information about documents, and the process that generated them. This effort should facilitate future works in search algorithms especially when all documents and their information are structured.

3.5 – Modeling Claim Documentation Rules

In lieu of the consideration given to the importance of formalizing documentation as-per claim issues, it is necessary to present a model for that purpose. Those Rules guide and control documentation and document flow. Tools to model Rules are numerous; O-O (Object-Oriented), DFD (Document Flow Diagram), ER (Entity Relational), and IDEFØ are candidates. In Figure-3.3, the author is modeling project documentation rules. Such rules are produced from contract requirements for documentation and changes management or workflows. The model developed here is modeled with UML language—a “Rapid Prototyping Tool commissioned by the Object Management Group [Booch et. al. 1998], with a mandate to formalize and standardize the O-O notation. The rules model developed here in Figure-3.3 is integrated in the DMID design at two levels: 1) table-field level, and 2) tables interrelationships.

Original document releases are automatically stored in the master Webfolder of the respective group that issued the document (part of the CPDIDCenter web server). All transactions will be logged to simplify the task of recreating audit trails. Other issues that are included in the DMID design are: version tracking, and status for claim issues. There are software tools (software code written in order to handle documents distribution, based on business Rules or process requirements) for Documentary workflows that allow issuers to dictate to the workflow engine things like: who can receive the document, the reply periods, and steps for approval. Workflow management systems are still in their early stages of development, but the automation of any workflow is based on a solid modeling base of main and generic business processes [Amberg 1996].

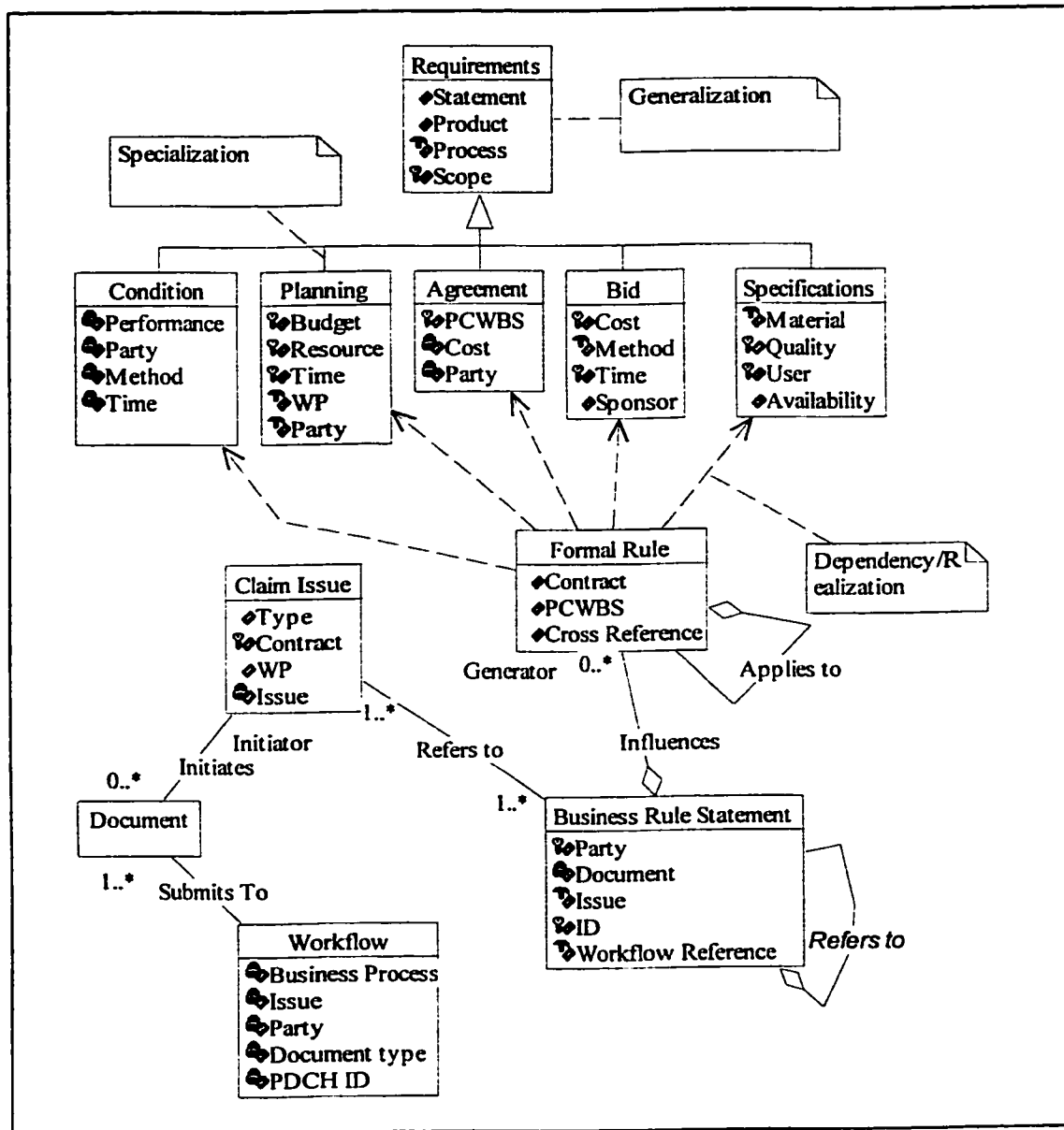

Figure-3.3: Model of Claims Business Rules that Influence Documentation

Automation of routine documentation tasks, can relief some expensive intellectual resources from the grudges of routine paperwork, and allows it to focus on critical management issues. In pragmatic terms a workflow might mean:

- Sending automatic notice when a response to an RFI is past due,

- **Generating Automatic document distribution, or automatic daily report initiation**
- **Qualifying the content of each document and flagging incompatibilities**
- **Knowing who is a project member and delivering documents to their URL addresses**
- **Queuing documents in paper-trail**
- **Producing status reports of the issues and the stage each document is at in the management process.**

Workflow is not within this research's scope. However, the CPDIDCenter framework will be designed to cope with group changes by stage, and the distributed nature of project information. Nevertheless, it is beneficial to know that project groups shouldn't scrap their current work processes pertaining to documentation in favor of any workflow model, before a thorough investigation of their project roles, duties, and contractual relations with each other's are set and clear. A central workflow model for the whole project is probably much better for uniformity.

3.6 – The Process of Case or Issue Documentation

Capturing human judgment in the shape of Soft-Rules necessitates looking at other components of the information system. Soft rules (i.e. Claims Management Rules) found in mandates, policies, guidelines, project cultures, apply to the approval process for a C.O., and reply periods for requests for extension [Jensen et. al. 1997]. Those rules, or business routines, come together to support the rationale behind certain decisions. Sample contract clauses, conditions are listed in Appendix A. In this research,

Documents such as: Requests for Interpretation of Changes, or a Notice of Constructive Acceleration to the Owner, Standard Operating Procedures, Validation Documentation, Safety requirements, Analytical Test Methods, Change Requests procedures are classified as “Project Definitions” Documents Class. Moreover, knowledge of the management function that released the document helps claims analysts construe further information about events that surrounded their issuance.

3.6.1 – Claims-Related Business Processes

This involves the rules and steps a dispute-related document, like a C.O. or an As-Planned schedule, has to go through during the course of construction. Those steps are agreed upon in business meetings, and sometimes are fixed in contract clauses. Various sources guide the user to documentation requirements and steps. They can be found in the Canadian Construction Document Committee CCDC [Short 1997], and the standard contract forms by the Federation Internationale des Ingenieurs-Conseils [FIDIC 1992]. Government acquisitions and contracts are normally guided with plenty of procedures. For example the US military building services has formal guidelines and standard procedures for: control, procurement, meeting agendas, project kickoffs, review and approval of plans, project status meetings, work statements...etc. See Appendix A for samples of those contract management procedures for proposals and other issues. Moreover, detailed document processing instructions can be modeled as workflow schema adept for automation; especially with the majority of documents are routine reports that are initiated on a daily, weekly, or a monthly basis. Example input/output process data is presented by [Ndekugri & McCaffer 88], which divided information—such

as site reports, weekly resource logs, monthly schedule outlooks, and monthly payment requests—into inputs to or outputs from management processes’ like cost control, claims management, and scheduling. However, like other early researches in IT, they mix data with information, and looks at documents in terms of their probable functions, not contents. Information, for that matter, is every change that may influence the outcome. In that respect, Documents are different from data or information, at least in shape.

3.6.2 – Data and Information content in Construction Documents

Documents contain data and give it a context. However, Processing this data will produce knowledge of project disputed issues and problems. Hence, documents may contain data and/or information. Data alone (i.e. not within the confines of a document) need other data along with it to inform the user about its context, purpose, and what function it is intended for. This descriptive data is referred to as “Meta” data or better known as Data about Data. In context data or information contained in documents, are easier to track, and process. A document is assembled from various sources of information or data from the project organization, and construction operations as illustrated here in Figure-3.4 which points out the many data sources, references, and peculiar data a sample document (e.g. Transaction/Correspondence) might include. The data contained is “parse-able” by computer applications, and by web search engines. Parsed contents are consequently ready for indexing by subject, keyword, or by association with claim issues and project events.

The indexing routine facilitates the search and retrieval of documents, by virtue of documents' contents. Internal references to project information objects can also be inserted into the document text, and hyper-linked for easy access when a person tries to view the document. A document, by and large, will go through an internal workflow (authoring, review, and annotation within one group of the project) before release, distribution, and storage in a file server.

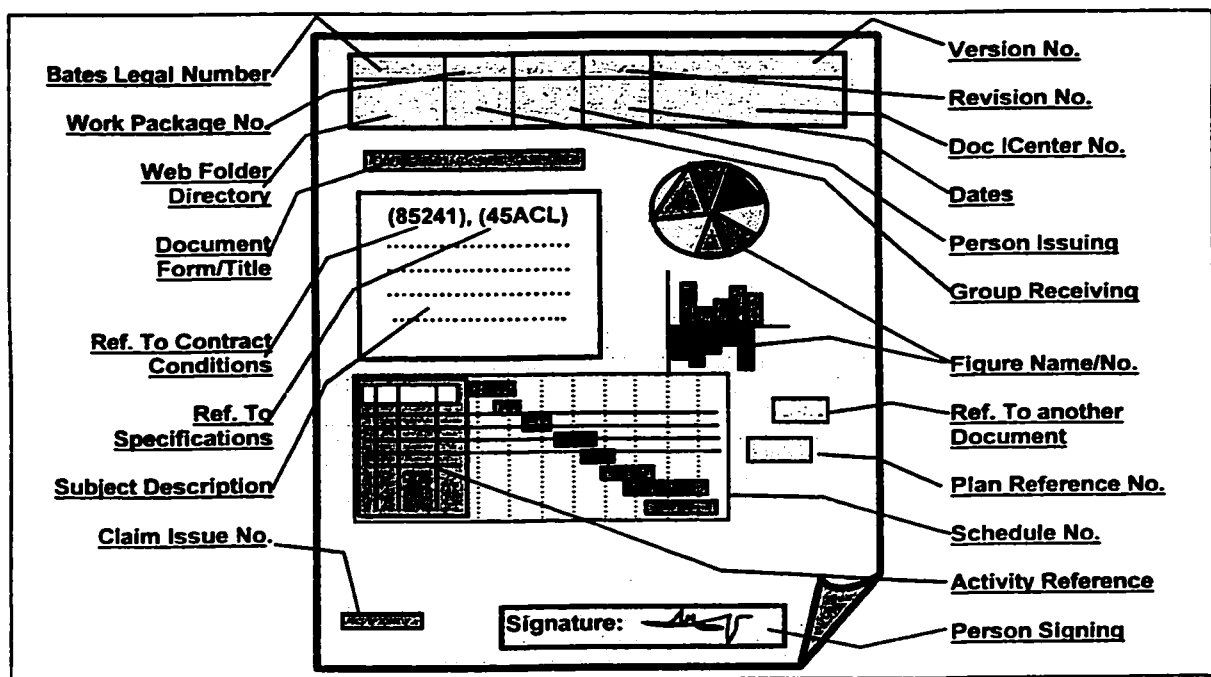

Figure-3.4: Information Subjects usually Included in A Construction Document

The Meta data that is parsed—from the document's contents or associations—is ultimately appended to the document's DMID record as will be shown in later chapters. Also, later in this thesis (Chapter 5), a whole chapter is dedicated to the analysis and modeling of claims information to establish potential database views and document summary logs to post on the CPDICenter website. Moreover such classification of

information is needed to structure the website pages and organize its contents or search forms. Since any document can be used in a claim analysis or defense situation, the database design and website takes this into consideration when designing the views, queries, and table structures.

3.7 – Document Information from Claims Analysis

The main phases or steps in the analysis of any construction performance impact claim (e.g. delay, acceleration, change...etc.) are illustrated in Figure-3.5. Those phases are sometimes overlapping and repetitive or cyclical.

1. Identification of Problem (Scoping).
2. Collection of Documentation
3. Discovery Orders
4. Analysis of all schedules and changes.
5. Analysis of project cost records.
6. Development of damages.
7. Expert opinions and deposition
8. Preparation of report
9. Arbitration or Trial

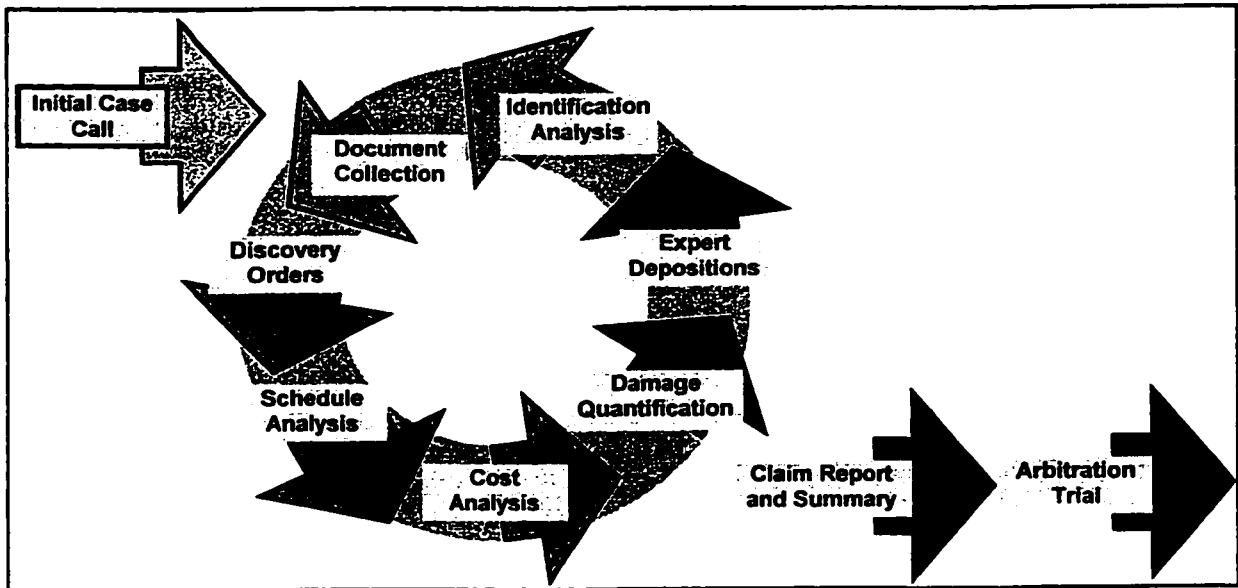

Figure-3.5: Main Phases in a Construction Performance Impact Claim Analysis Case

3.7.1 – Phase 1: Analyze and identify issues

This includes examining contract documents, and testing problems pertinent to language of contract. Claims analysts have to obtain and copy relevant documents from all available sources, in order to examine the data and establish issue folders using material from those obtained files. Issues can be organized chronologically and supported by physical descriptions (photos, drawings) of the project. Hence, try to establish liability for each problem, and find a preliminary analysis and estimate of the impact of each issue on project time and cost.

3.7.2 – Phase 2: Analyze all schedules and changes

All schedules (As-Planned Updates, and As Built) are collected or prepared from computer files. A comparison then would be possible between the as-planned and as-

built schedules. This aids in finding *impacted as-planned* schedules with constructive and directed changes and other problems. Also aids in identifying delay times, and any loss of productivity times. The number of delay days due to owner, designer or contractor has to be delineated for realistic and reliable delay analysis.

3.7.3 – Phase 3: Analyze Project Cost Records

Cost records combine files related to direct costs, site overhead, home office overhead, and lost opportunity or investments. This is carried out by examining the contractor's pre-bid estimates matched to the list of quantities developed by the owner. Those early estimates are compared with actual costs to determine a) the cause of extra cost, and b) the liability for extra cost.

3.7.4 – Phase 4: Develop damages

Damages (financial or time) from each issue or dispute are apportioned based on liability. Apportionment is necessary in concurrent delays or concurrent problems affecting productivity of the contractor crews. Critical activities take always a higher toll in terms of time delays, and eventually lead to ripple effects.

3.7.5 – Phase 5: Prepare Claim Report

The report presents a background on the project. A description of the project and summary of the issues are also enlisted. Usually then, pertinent contract clauses are

highlighted. Each of the disputed items are discussed for causation, liability and damages. Scheduling illustrations are important to discuss delays. An emphasis should be put on the recoverable damages. Input can be drawn from expert consultants with experience such as: schedulers, engineers, cost specialists, contract specialists, claims specialists. Taking the analysis task of Figure-3.5, and detailing it further we get the following main analysis sub-tasks as listed in Table-3.1.

Table-3.1: Steps for Claim Investigation and Analysis

Main Steps
1. Examine and assemble relevant documents
2. Interview project participants
3. Establish reasonable As-Planned Schedule
4. Identify alleged delay issues
5. Prepare As-Adjusted Schedule series
6. Extract As-Built Schedule data from project records
7. Prepare As-Built Schedule
8. Compare As-Planned & As-Built Schedules to As-Adjusted Schedules
9. Establish cause for variance between As-Planned & As-Built Schedules
10. Identify party responsible for delay
11. Allocate delay caused by project participants
12. Calculate & plot As-Built resource requirements
13. Calculate & plot As-Built resource expenditures
14. Identify period of overtime and multiple-shift work
15. Identify areas & extent of disputed work & out-of-sequence work
16. Identify and quantify unusually severe weather conditions

3.8 – Discovery Procedure

Discovery as a process, as shown in Figure-3.6, is expensive since it entails multiple visits to various sites of the contract adversaries and searching for specific

documents that are organized in a fashion peculiar to the adversary's own criteria. Copying is part of the process. Furthermore, parties may have only one opportunity to recover documents from each other.

Comprehensive or total document retrieval requests (List of Particulars) is not always possible because any party can refuse to release documents that it classifies as proprietary. Among proprietary documents are expert reports, and legal deliberation letters prepared for trial by lawyers and which might expose a contractor's strategy and weaknesses. Claims are usually developed as proposals to the Owner or Construction Manger for equitable adjustment under the terms of the contract, and frequently, the issues can be settled in negotiation using the clauses pertaining to changes and extra work in the conditions part of the general contract. Even where entitlement is strong and chances of a negotiated settlement are good, it is important to present your case for equitable adjustment in a clear and complete manner if the buyer is to fully appreciate your position. If settlement is not possible, some contracts contain arbitration clauses which detail the procedures for settling contract disputes. When no arbitration clause is included in the contract, the parties might still agree to arbitration. Such arbitration also requires that the contractor present its case in the best possible manner if he is going to convince the arbiters of the validity of any proposed contract adjustment. In government contracts (<http://www.fedpub.com/seminar/gcc.html>), contract disputes, which are not negotiable between the parties, are taken before a Board of Contracts Appeal or Claims Court of which there are many to service the various arms of government.

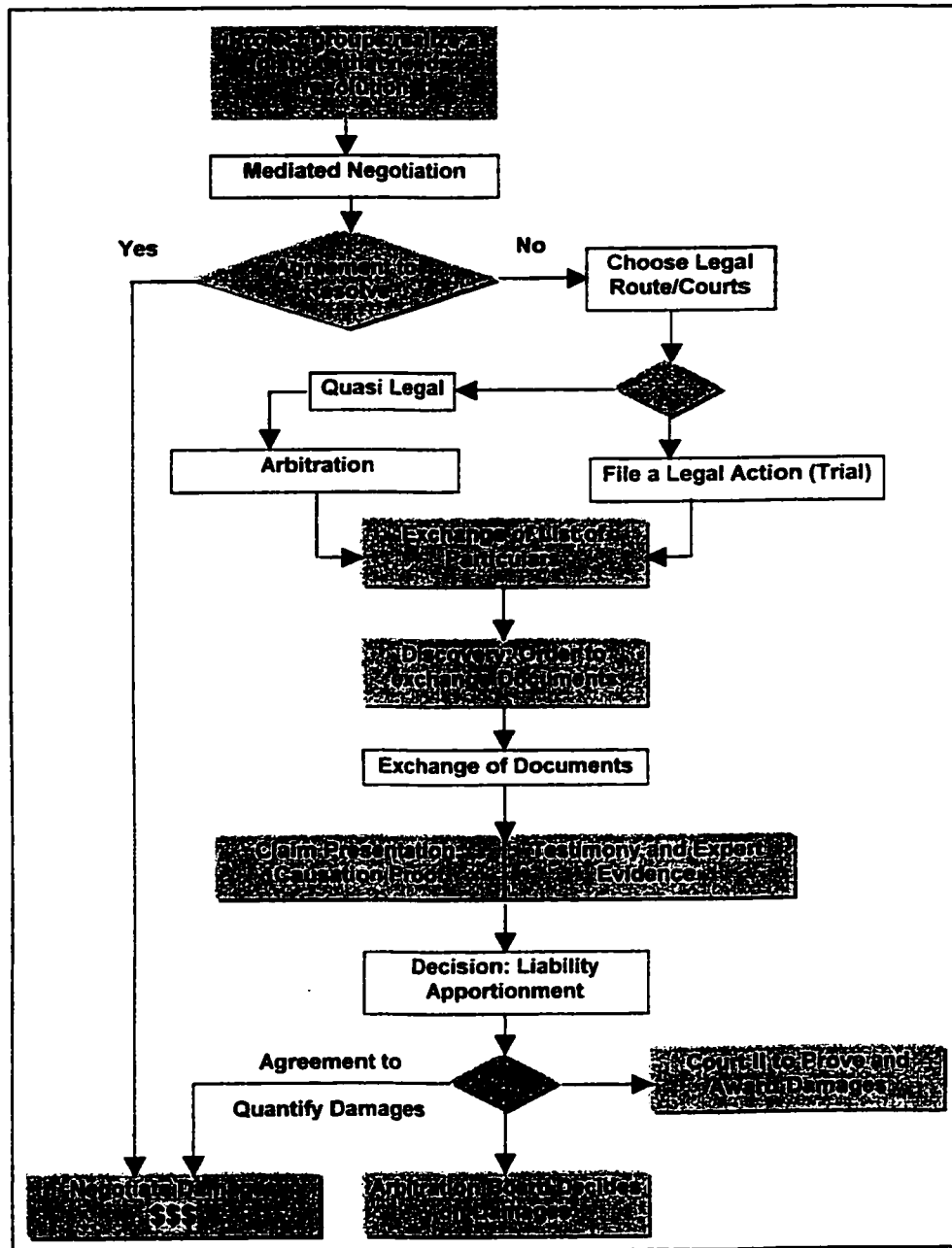

Figure-3.6: Main Steps involved in a claims documentation discovery procedures

These Boards and Courts are generally comprised of judges with particular experience in the specifics of government contracting and in a particular branch of government. These agencies function as legal bodies and have built a large body of

opinion relative to government contracts. If negotiations fail, there are courts, boards and arbitration panels to hear disputes and give decisions. Arbitration is generally faster and more informal than litigation and is most effectively employed on smaller disputes. Litigation is generally a more costly and lengthy method of settling a dispute. Discovery procedures are used to develop documentation for claims. Project groups go to court and request a court order to be served to their adversaries to release “particular” documents that are deemed beneficial in preparing a claim or defense thereof. A list of particulars lists all documents any one group needs to recover or copy from others in the project.

3.9 – Project Management Process Information

Construction projects are hierarchical by nature, and their information structure, are also hierarchical because every sub-component is part of a bigger system, which altogether make up the project. This simplifies the control of a project’s complexity and delivery of construction products in concordance with contract requirements. Delivery of requirements is carried out incrementally in an iterative fashion of overlapping processes. Processes aggregate to become operations, which in their turn are work packages. The PMBOK [PMI 1996], also views all project management tasks as processes that may be iterative and overlapping by nature.

A snapshot of some document flows amongst various management activities is illustrated in Figure-3.7. The basis for the documentary flow has been laid out in Figure-1.2, where every document can participate in the construction management processes in one or more of the four roles (input, output, control, and mechanism). The documentary

flows shown in Figure-3.7 emanate from participants and traverse to other participants. Connotations that are drawn from those flows are instilled in every document (later added as fields into the record of each document in the DMID), in a way that makes every document contiguous on its source, destination, and purpose (e.g. design update, directives, and method statements). Interaction between the groups' different management processes should be included in a collaboration model that can become the basis for a document workflow control object (small program to control workflow in light of contractual relations). [Dado & Tolman 1998] supports this view and produces other specializations (decompositions) of the Management Control Object. Specializations classes include Time, Cost, Change Request, and Contracts. Documents issued by any project group are further distinguished by knowing which stage of the decision cycle they subscribe to. In Figure-3.7, for example, various simultaneous document flows (numbered arrows) are exchanged amongst groups' functions are modeled to assist in this research's document information model development. The functions resemble each group's roles in the management process.

Such simultaneous flows (Figure-3.7) reveal the decision process that a project organization follows (here it is a specifications update case)

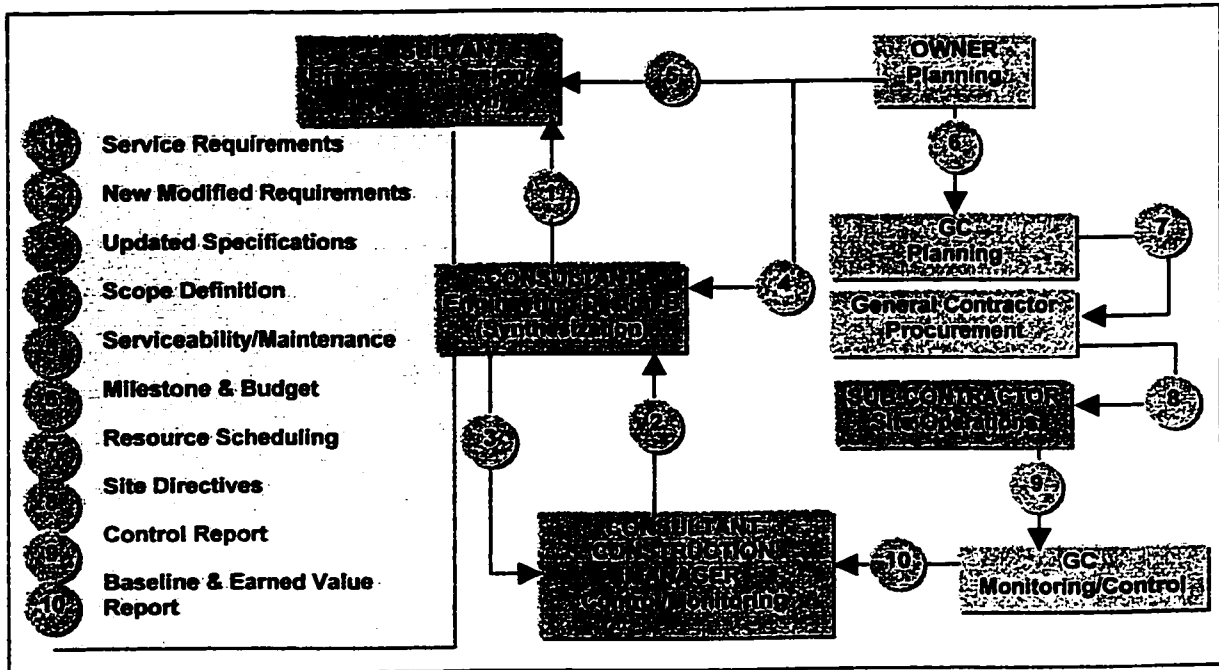

Figure-3.7: Document Flow Diagram between Groups Management Functions.

3.9.1 – Understanding Detailed Document Flows: An Example

Each project management or operational function/process will reference other documents like contract agreements, clauses of conditions...etc. Hence, there is four sub processes in each function/process block, which are: Entry, Task, Validate, Exit, or ETVX for short. ETVX is an IBM novelty, used in software development, and used extensively in process developments that are based on the Integrated Definition Technique IDEF0. An example demonstrating the use of ETVX is presented herein after. In Figure-3.8, the CM relays a Site Directive to the contractor requesting a change. The Contractor reviews the directive, calculates the cost of the addition/change, forecasts the impact, and replies to the CM with a proposal and a request for impact adjustments. The documentation involved is mapped in Figure-3.8, where the steps are broken down into internal management process of: Entry, Task, Validation, and Exit. If documentation

processes are formalized, in a similar manner to the ETVX, then all documents that were involved in the claim or dispute event can be recalled or retrieved seamlessly without so much of a search or a guessing work.

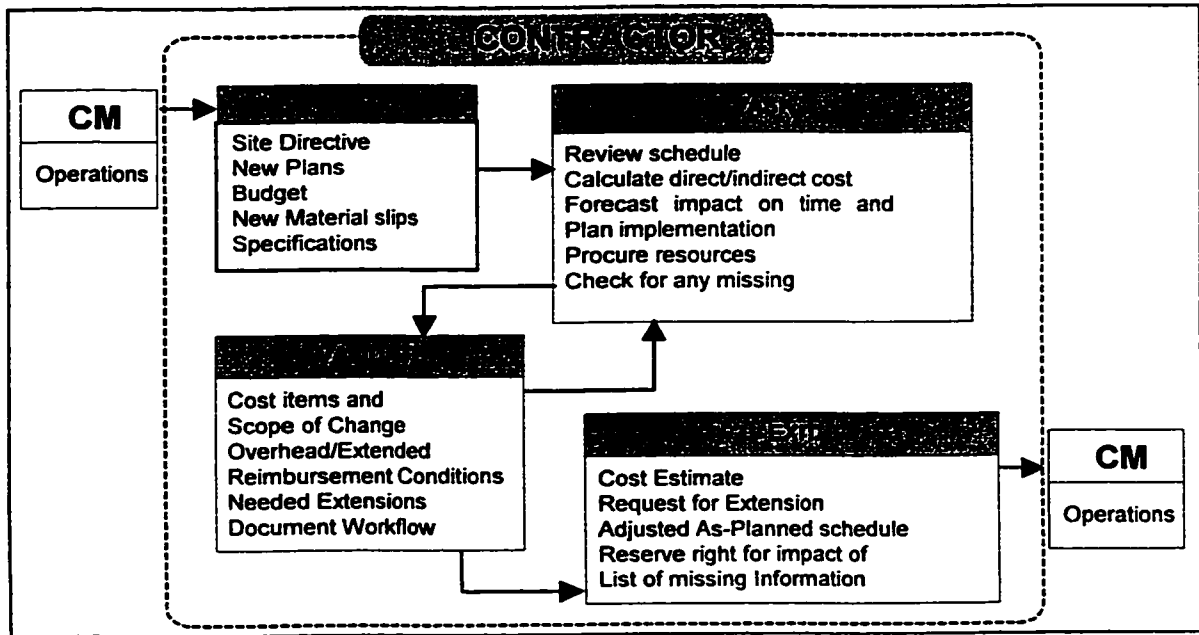

Figure-3.8: Internal Document Processing System Using ETVX Platform

3.9.2 – Incorporating the CPDICenter with the Project Enterprise

The CPDICenter is deployed at various levels in the organization. In Figure-3.9 the project participants are grouped according to their functional involvement or role in the project constellation. Each group has its own internal organizational structure, which might be dedicated to one project, or many project engagements. The CPDICente is built to serve one project; hence, each project will get its separate CPDICenter.

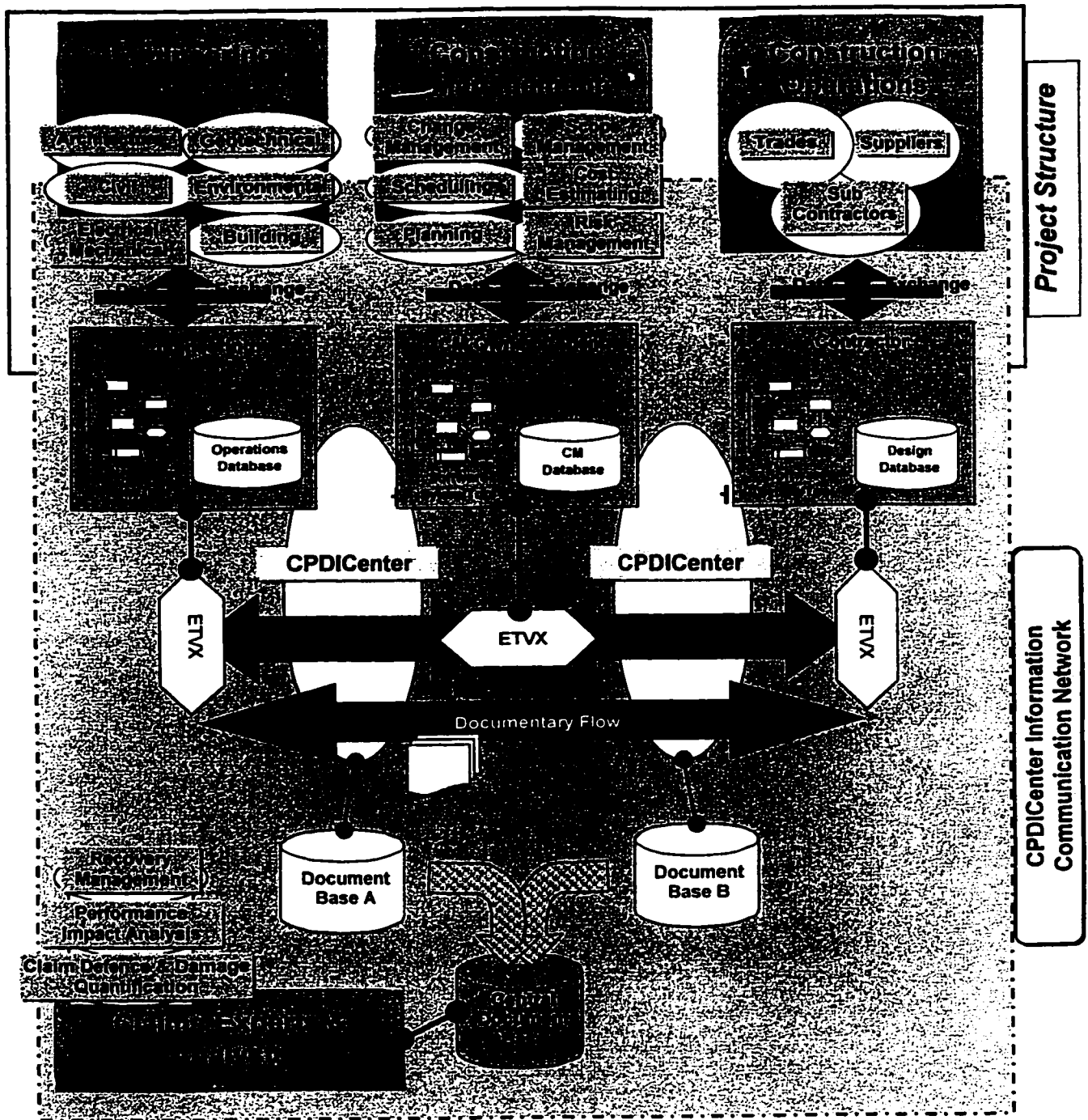

Figure-3.9: Incorporating the CPDICenter into the Project Enterprise

The sample groups included in Figure-3.9 are:

- 1. Engineering:** involves mainly consultants who specialize in supplying new and changed works drawings and offer also interpretations to design changes.
- 2. Construction Operations:** include GC, Subcontractors, Suppliers, and Trades. They deliver owners' requirements using directives and instructions received from the CM and the Engineering Processes.
- 3. Construction Management:** encompasses many services, such as planning, cost estimating, and scheduling. One or more sub-groups that work independently or jointly with the main CM offer those services.

Information exchanges among major groups are document-based in the most part. Documentary exchanges or transactions are cleared via the CPDIDCenter and registered in the DMID. Documents are stored in web servers. Details of CPDIDCenter Framework and system architecture are presented in Chapter Four. The ETVX filter resembles that documentation rules pertaining to claim management, and workflows are in place (refer to Figure-3.8). Project groups, and Analysts can access the DMID via a web browser to retrieve any documents about a specific event or work item. Each project group maintains its own software systems and process database, where such databases are proprietary. However, certain sectors or tables of those databases can replicate inside the DMID for sharing. Some pressing issues will be to identify where the information is? Who owns it? and what are the information sharing and exchange rules that are spelled out in the contracts?

3.10 – Data Models

Modeling of documents' information result in data structures that are essential for the design of the CPDIDCenter's DMID. However, various factors should be under consideration when designing and implementing the DMID, among which:

- Various roles documents have in the project
- Document Classes, subclasses or categories, and individual titles
- The CPDIDCenter's communications architecture, which will adapt to:
 - Project Organization and changes in that organization with stages
 - Functional needs like storage, and retrieval of documents
- Elided risks, and claim causes inducing impacts to normal work performance.
- Need for flexible and established modeling language that conveys opinion easier than text, and has:
 - Constructs or building blocks
 - Syntax defining each construct
 - Associations, dependencies, and generalizations or decompositions
- Complexity and how limiting the amount of detail in a model can conceal it.
- Existing dichotomy between document classes, project subjects, project groups, and work process information.

Moreover, functional issues like document versioning, and viewing rights all can be modeled. The CPDIDCenter allows system users to retrieve documents, but not to change them. Annotations are added to a document's record in the DMID. Any changes made to a document will create a new instance hence a new version of the original document. Contemporaneous construction documents, produced during operations, include both routine (repetitive) parts, and one-off or non-routine parts that change by the

occasion or the document purpose. Routine parts include: dates, names, sites, cost accounts, WBS codes, subject, while non-routine parts relate to the specifics of project activities, or the events in question. The data modeling techniques used in this research are listed in Table-3.2.

Table-3.2: Modelling Techniques Used in the Research

Language	For	Software
UML [Booch et. al. 1998, Eriksson & Penker 1998]	<ul style="list-style-type: none"> o Document information Models o Business rules o Sequence Diagrams o User Cases 	<ul style="list-style-type: none"> o Rational Rose® UML Toolkit o MS Visual Studio 6.0® Visual Modeler
Object Oriented [Rumbaugh et. al. 1991]	<ul style="list-style-type: none"> o Information Modeling 	
Entity Relational [Chen, P. 1977, Elmasri, & Navathe 1994, James, Martin 1987]	<ul style="list-style-type: none"> o Conceptual ER Model o Logical DMID Design o ER o Design/Implementation 	<ul style="list-style-type: none"> o MS Access® 2000 o Embarcadero ER Studio®
DFD [Kroenke 1992]	<ul style="list-style-type: none"> o Document flow Scenarios 	
Explanation of the notations and constructs of all modeling languages used in this thesis are presented in Appendix B		

3.11 – Users' Search Criteria

Two user types are of concern here; the ones who know about the project, and have been directly involved in the realization process, and Claims Analysts, who try to understand the project from whatever documentation the system has to offer. In extensive interviews with claim management consultants, the researcher collected various points of view regarding the future document system. The most important factors to take into consideration, with regard to search are presented.

The number of people who are involved in every aspect of the project, all the time with every stage, usually is not that many, because most people get involved in one stage of the project and leave to other projects or other stages when finished. Claims Analysts are different cases, because they probably have never been to the actual construction site or seen the project documentation before the dispute erupted. From interviews, and extensive literature surveys, a wide range of search criteria and requirements that need to be included in the CPDICenter, or for further investigation, have been identified. These functional considerations that need attention are summarized hereinafter.

3.11.1 – Search and Retrieval

Professional Users query for documents from different perspectives or views, and by association with certain project events, people, and sites. For example, search can be in any of the following views or queries:

- Contract Workpackages (WP)
- Work Breakdown Structure (WBS)
- Cost Accounts
- Changes and Change Orders (C.O.)
- Paper trails
- Construction operation or management process affiliated with the claim
- Documentation rules and procedures. For example a Request For Interpretation (RFI) has to be accompanied by a drawing or preceded by a drawing, and a RFP has to be followed by an estimate of cost, time, and quantities...etc.

- Bid forms, and estimates
- Contract agreements, clauses, conditions, and specifications.
- Parameters, like dates, weather conditions, numbers, reference numbers, roles and names
- Events; incidents; and milestones.
- Full text search for specific concepts, phrases, or images or certain order of words.
- Cross-referenced documents.

Most searches are made in hindsight (perception after the fact), and users are trying to understand the project's history from contemporaneous documents, also find certain documents with clear indications as to the status on pending issues. Hence, things like Status and Version control have to be in the information available on events, and documents associated with them.

3.12 – Legal Considerations

Construction participants have different views of the process; nonetheless, they share two common knowledge references:

1. Legal information spelled out in documents like municipal bylaws, building codes, design methods, structural performance criteria, duty of due diligence, binding legal commitments to offer professional opinion, and liability.
2. Contractual information that most often recurs in contract agreements, specifications, promises to deliver, letters of understanding, payment agreements, drawings, plans, and schedules.

Documents are proofs of causes, entitlements, and damages thereof. Barristers and triars-of-fact rely, when defending or appealing claims, on contemporaneous documents to interpret project events. In an acceleration case, the contractor, before admitting its costs to the trial, has to prove either that the acceleration was an affirmative action in response to an explicit order by the owner, or as a constructive one in response to an implied order from the owner. Implied orders are construed from things like an owner's refusal to grant the contractor an extension for an excusable delay. Courts require documentary evidence [Jensen et. al. 1997, Baram 1994] to prove remuneration entitlements for damages like productivity deterioration, higher material costs, extra equipments, or overtime incurred in the process of accelerating. Escrowed bid documents are an option for the project participants to consider [Schroedel 1997]. This is used to make sure that contractors' bid estimates and methods are binding. However, this applies only to pre-construction documents such as bid forms.

The admissibility of electronic documents to arbitration or courts is becoming as a non-issue, but this is contiguous on few basic principles [Ott 1998] that have to be addressed:

- The electronic signatures and the authentication of the identity. To know who signed a certain document, and to be sure of their identities.
- Access and Authority control. To track everyone's access and action with the documents, and to ensure that nobody controvert receipt of a document.

To elevate the status of electronic documents to a proof/evidence status, and to precisely enumerate every document in the project, a sworn attorney, notary, or seal-of-oath can carryout an Automatic Affidavit for each document, immediately after the release of each document. This service is possible either by retaining the necessary personnel for it, or on a document-by-document basis, or by subcontracting this service to a third party. There is also the Bate code in Canada, which is used in the legal system, for document enumeration and coding. Each document can be coded with the Bate code to facilitate the exchange of documents during the discovery period.



Chapter Four *Proposed Model: CPDICenter Information System Architecture*

4.1 – Introduction

Construction projects are temporary enterprises or organizations, with functions that need constant access to information. Most of this information is produced and reproduced as documents. However, project documentation is an individual task carried out independently by project groups, and that consequently results in many documents getting lost in the paper-trail, or not distributed properly to recipients, and not being classified for storage according to any project standard. That motivated CPDICenter development in order to streamline documents' publishing, exchange, storage, and subsequently identifying web technologies for document storage and retrieval. The CPDICenter is Web-based, and suggests a new paradigm in document sharing and exchange amongst project groups. It builds on the premise that most documents have been generated from computer programs—electronic files—which makes it feasible to parse (read their contents for classification and storage purposes) those documents by search engines, or digital scanners, or allow users to register those documents and classify them via a web form. Since every document stands the chance of being recalled or used in a

dispute, then all project related documents should be registered with the CPDIDCenter's database (DMID). Supporting electronic-based documents has certain benefits, of which:

- Minimizing document transaction times
- Minimizing or eliminating onsite physical storage space for paper documents.
- Viewing and printing are controlled or made on demand via access rights.
- Content parsing by programs and digital scanning for indexing and database updating is possible with electronic files.
- With the advent of new document content standards like XML it is now possible for programs to understand the contents of those documents. Using XML, the contents of those documents would be structured according to a predefined schema and a semantic dictionary.

4.1.1 – Technology Infrastructure

The World Wide Web (WWW) offers a wide range of applications and tools, to help develop new kinds of information systems that can serve as a universal, single point of access for nearly all of a project's strategic information. There are many ways for web technology to be used within large construction project organizations to advance organization-wide strategic goals, most importantly in improving communication between clients, consultants, contractors, and suppliers. With proper tools, each project group can host a server, or become a client with other servers in the project.

Given this potential, all files will be available to other project groups who can in their turn download from each other's using the CPDIDCenter website as a gateway or portal. Following is a list of some typical problems concerned with document authoring,

processing, and delivering of information within construction project organizations especially large ones:

1. Incompatible, proprietary document file formats
2. Expensive, non-intuitive or even non-existent document viewing tools that need frequent upgrading.
3. Massive printing budgets for documents that are under-used
4. Out-of-date documents' information locked in obsolete systems
5. Difficult access to critical documents
6. Redundancy and duplication of information about documents or project events across different groups' networks.

4.2 – Building a Solution

The first stride in solving the documentation problem is to recognize its value as an Enterprise-Wide activity, not as a personal task carried by individual groups. Any DIS must add value by improving or innovating the process, and by better control over information. This means that the DIS framework for the project must encompass:

- A flexible communications model (internet, intranet, and extranets) to bind geographically diffused users.
- A Uniform User Interface (UI) to document information repositories.
- Standard format for document registration for any document issued anywhere in the project.
- Standard document classes, categories, and titles across the project.
- Uniform search facility easy to use by any project echelon, or claims analyst.

- Central database (DMID) to house all documents' Meta information.

Groups' individual OBS (Organizational Breakdown Structure), and their contractual relations, influence the flow of documents amongst them. Document flow means that documents are moving through a physical network. Openness, extensibility, and adeptness to changes in project delivery are basic implementation strategies to enable as many groups as possible to join in or sign-off the proposed CPDICenter. Project Delivery is most commonly referred to as the procurement method and it is a triumvirate of a project organization, a contract type, and a management technique, as shown here in Figure-4.1 [Moselhi 1993]. All three elements of the Delivery affect the design of the DIS, and the flow of documents.

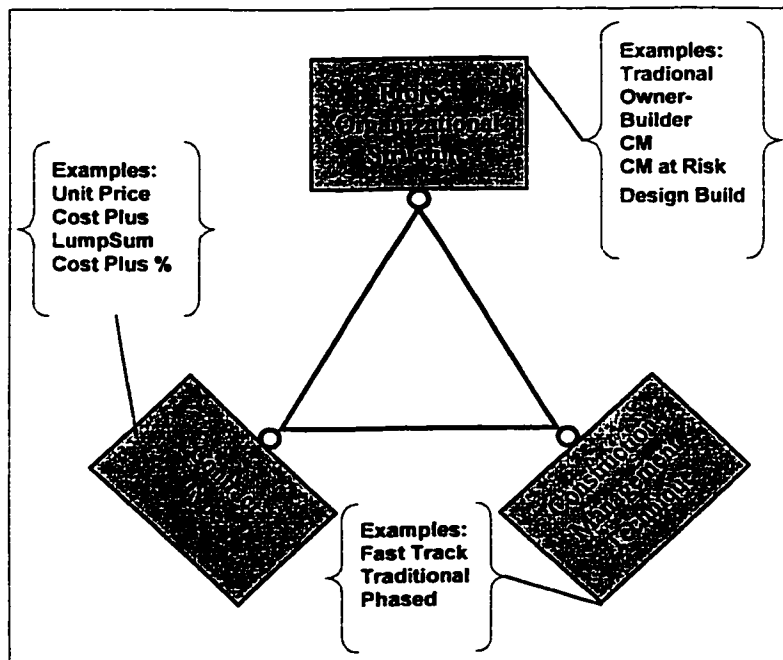

Figure-4.1: Project Delivery Triad [Moselhi 1993]

Some of the technical ramifications, insofar for creating a flexible control and management system for documents, include the use of semi-structured DISs [Kroenke 1992; Laudon et. al. 1997]. Semi-structured DISs allow programming or automation of routine tasks with enough maneuverability left to customize document processing steps, document distribution, and storage. For that matter, interoperability amongst project groups is necessary for the future DIS to succeed. However, the interoperability amongst groups' systems or the lack of it, thereof, is due in part to the lack of a common information model for documents control and storage. The term Islands-of-Technology was coined to describe similar situations.

It is an exception to have all project participants using the same EDMS platform or software; indeed it would be much easier then for all involved to exchange documents and transfer information among themselves. This chapter addresses these problems, by formalizing a new information system framework paradigm (the CPDIDCenter) to capture all project documents from all groups, and stores them in a central repository for all groups to access at any time [Hammad & Alkass 2000-c]. The CPDIDCenter acts as a virtual clearinghouse or hub. The CPDIDCenter hosts as well the DMID to hold a record for each version or revision of every document. The key steps followed to achieve those goals are charted in Figure-4.2. Those steps overlap or progress out of sequence; nevertheless, they embrace the major or key components of the methodology. Progressing towards a CPDIDCenter information framework, as shown in Figure-4.2, is carried over multiple converging tracks, namely: 1) capturing information about documents in light of their usefulness and how they are used in analyzing claims. 2)

Documentation rules, as spelled out in contract conditions, agreements, and claim management clauses. 3) The state of affair in impact claims analysis, and classification of the information that production and management processes might need from documents, 4) the prevailing modes of communication and document transactions amongst project groups to support operations. DFDs are useful in designing the DMID.

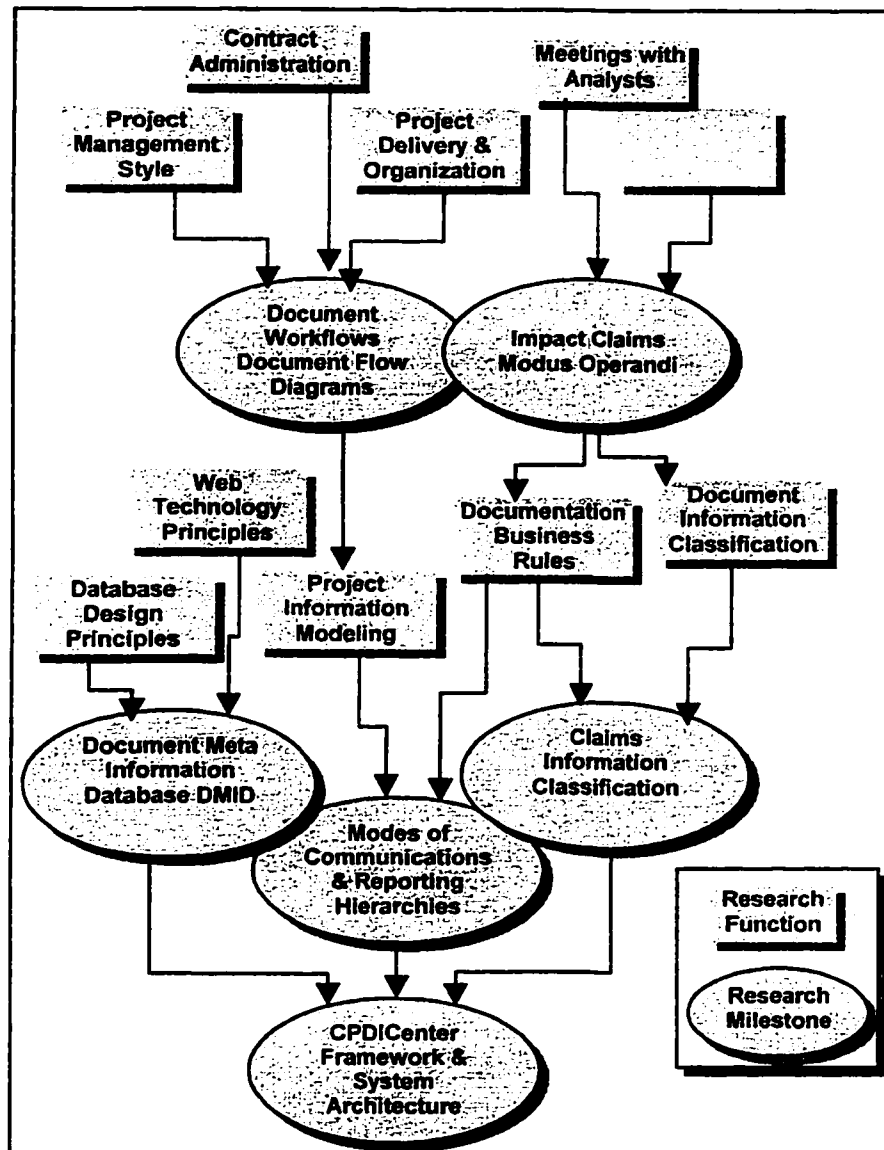

Figure-4.2: Main functions and Development Milestones for the CPDIP Center.

4.3 – Project Structure and Communications

This structure defines the fashion in which project participants wish to organize themselves in. In most project structures, there will be an owner, an engineer, a consultant, and a contractor, or builder, and a host of specialty subcontractors and suppliers. Therefore, it is essential, when establishing the CPDICenter framework to account for:

- Number and types of project groups.
- Contractual relations amongst the project groups.
- Communication channels, reporting hierarchies, levels of authority.

The project organizational structure presents a conceptual static model of the physical communications' network that would bind all participants. Some of the possible project organizational structures are shown in Figure-4.3. The different Construction Management (CM) organizations depicted in Figure-4.3 are adapted from [TCCM 1987]. Other variations are available and conceivable [Beaumont 1997] based on project financing and contract type. Project organizations and their spin-offs (variations) are triggered by market demand and financing methods used to meet owners' requirements. Also the level of technological sophistication required in order to deliver the project, influences project organizations. Groups should allocate special teams, or persons from their own functional departments to manage their interests and involvement in a project. Concerning contractual relations, the type of contract dictates the cost remuneration or compensation criteria for normal or changed work. Some common types include: Cost

Plus, Unit Price, Stipulated Price, and Guaranteed Maximum price. Ideally there is a contract type that works best with specific project structures.

4.3.1 – Influence of Project Management Technique on Document Control

This is the construction management method used in delivering the project requirements. Most common types are traditional, fast track, phased, CM at risk, and CM guaranteed maximum price. Claims' intensity and frequency are influenced by the construction management technique used. As an example, a Fast-Track project with a Lump-sum contract involving many master builders bidding on a Cost Plus basis, and without a clear scope or sure estimates of quantities is possibly going to have lots of claims. Generally, a Fast Track management system could face a continuous challenge for redefining the scope of works and ultimately the costs. In general, the type of the management system and its companion the management contract will dictate:

- The responsibility for the designs, and work plans.
- The design team's responsiveness to changes in requirements, and mistakes.
- Financing needs and cash flows for the project
- How requirements' complexity, overlapping between Workpackages, and operational bottlenecks are going to be managed.
- Project groups' exposure to risks, liability, and the flexibility in handling unforeseen conditions
- The owner's level of expertise and involvement.
- Dispute types and dispute management business rules (e.g. arbitration requirements, change order documentation, and recovery management.)

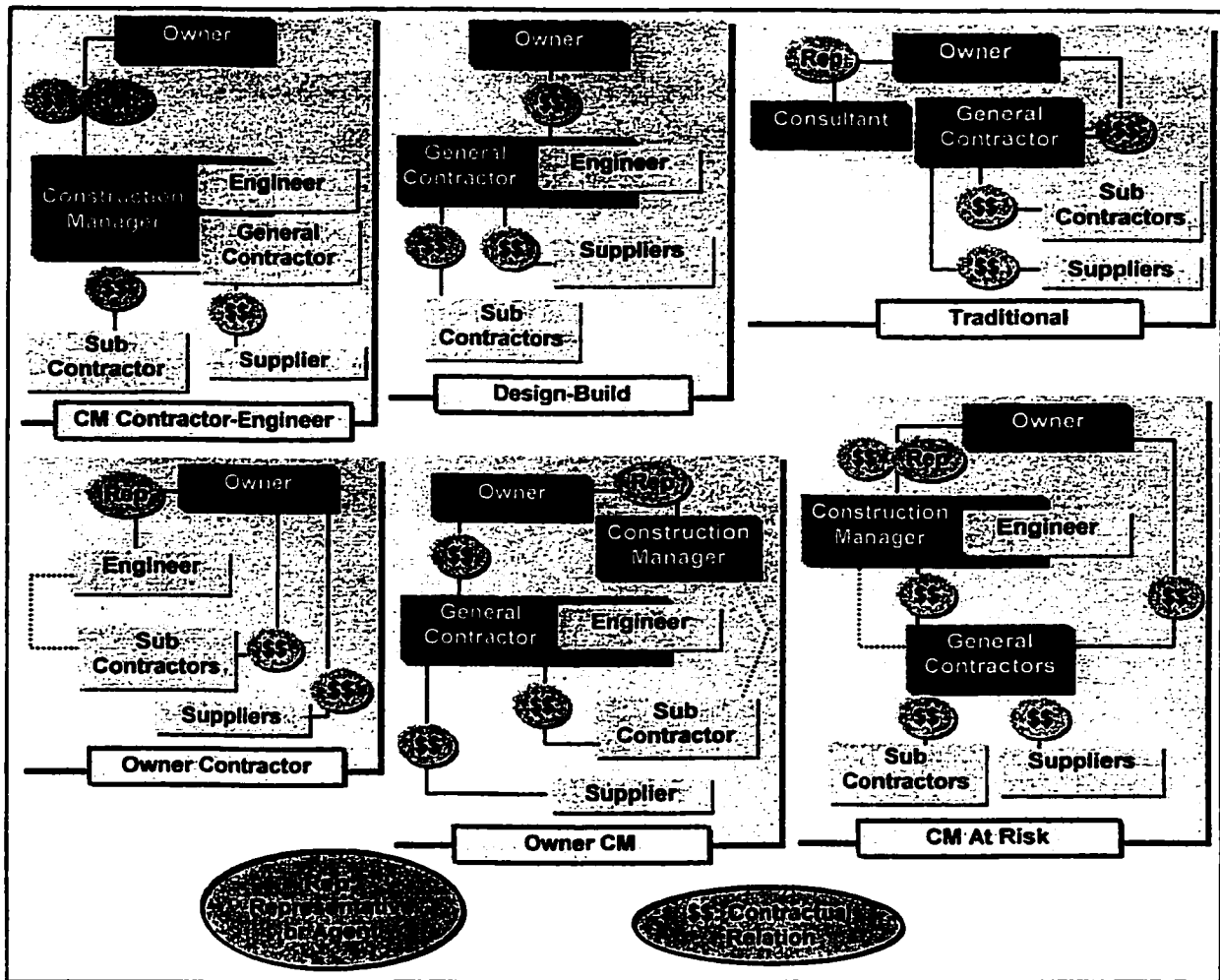

Figure-4.3: Some Project Organizational Structures and Contractual Relations (alternative CM organizations are adapted from [TCCM 1987])

4.4 – Document Control for Distributed Project Groups

Complex projects present a multi-user, multi-project, and multi-site environments with sophisticated specifications and end user requirements. Such projects, as illustrated earlier, will use many organizational structures, contract types, and management techniques to deliver its objectives. Projects, in general, can face changes in their communications and document management needs simply because the project delivery

method or one of its components has changed at any phase in the operations. Web-based communications model architecture offers a feasible, and affordable solution to such problems. The Web platform is excellent for rapid and random access to information databases. An organization the size, scale, complexity, diverse functions, and the geographical dispersion of a big construction project is properly described as an enterprise. Enterprise information requires the constant access and use of operational and historical data–documents in particular. Project documents are continuously obtained, processed, stored, transferred, and disseminated, which creates intense document flows between management functions. To control these flows, one needs a flexible information and communications architecture for easier collaboration, and most importantly to streamline document transfers. Other important factors acquired from understanding document flows amongst management or operational functions are how to locate the necessary document databases and servers in the management cycle.

4.4.1 – Physical Communications Network Needs

In the path to develop a framework for the CPDICenter, the communications component is essential in order to complete the loop necessary for information exchange between all parties involved in the project. A conceptual model of the network can easily be devised from the project structure. Further levels of detail can always be added to a project’s communications model, to delineate and locate each participant’s dedicated project entities. Plotting this information gives a map for any information system to locate and route documents transactions and locate necessary databases. Current communication schemes in the industry present ad-hoc networks of legacy systems. This

in itself presents a dilemma proportional in magnitude (cost and technology) to the number of groups joining the system. An example of such a communications dilemma is presented in Figure-4.4. This complex communications network represents “all possible” transactions between only five main participants, each maintaining a Site-Office and a Head-Office.

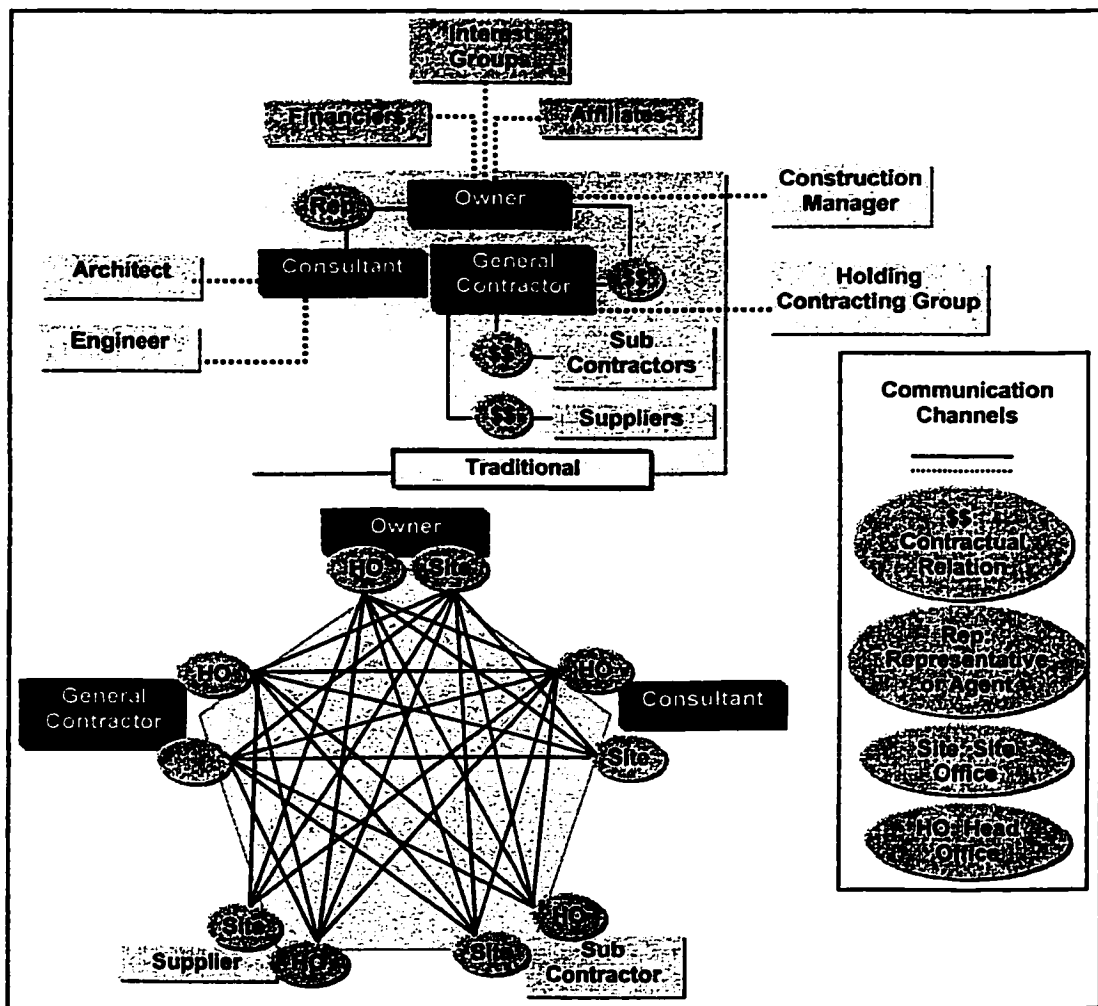

Figure-4.4: Multi-Group Projects' Ubiquitous and Complex Communications

Hence, for a project with 10 groups they will need 4950 channels of communication. This value can be derived from the following mathematical equation:

$$N_{dc} = [(N-1) * (N)] / 2 \quad (4.1)$$

N_{dc}: Number of direct communication channels

N: Number of project sites or groups wishing to be on the paper trail

In Table-4.1, the number of necessary direct channels is very high for any project with more than ten groups. Those channels reach as high as 4950 for a project with a 100 groups or sites or entities that have to be connected with each other. Communication channels may indicate direct networking links or report protocols. Due to reporting hierarchy and contractual relations, project groups initiate the channels they need and restrict communication between certain parties in the project.

Table-4.1: Number of Necessary Direct Communication Channels

N _{dc} = [(N-1) * (N)] / 2	
Number of Project Groups	Number of Direct Channels
2	1
4	6
10	45
25	300
50	1225
100	4950

This doesn't come without a cost. Some disadvantages for example include:

- Duplicated, Redundant, Inconsistent and asynchronous document distribution. Also, expensive networking is needed in order for the participants' systems to communicate and share files.

- Because information is not managed centrally, and document management is a personal not a project issue or not the property of the project, access to documents is not always guaranteed. Also, access to mission critical data, like work plans or specification updates, is not uniform, and inconsistent.
- Seamless access to document-bases, and browsing through project information libraries is not supported. Hence, users need to know the exact address for any document they are looking for.
- Many redundant resources like document databases and servers, are needed which imposes extra costs on project groups.

4.5 – The Document Information Center

4.5.1 – CPDICenter Structure

The new project artefact devised in this research—the CPDICenter—will overcome the complexity presented in Figure-4.4. Similar to banking and business transactions, the CPDICenter takes charge of document transactions and storage. It works as a communications hub (central), and can have a document workflow control in place to manage claims documentation. Project organizational hierarchies are diverse (see Figure-4.3), and currently the industry is lagging in establishing communication frameworks precisely for project communications or for exchanging and storing construction project documents, especially for a temporary organization like construction's. This research identified that discord and how it hinders document distribution, publishing, and storage. The proposed framework (CPDICenter), shown in Figure-4.5 for a traditional project organization, tackles constraints like geographical dispersion, and offers a flexible framework adaptable to any project structure, contractual

relations, group roles, and documentation workflows. CPDIDCenter communications framework is web-based, making use of Internet standards such as: TCP/IP, HTTP, SMTP/POP3, and HTML. Every center binds (virtually) those project groups that have contractual relations with each other. For example, the traditional project organization in Figure-4.5 has an owner who hires a General Contractor (GC), a Consultant, and probably a Construction Manager (CM), and in their turn they hire their subcontractors and sub consultants. To overcome this complexity, all groups have to communicate through the CPDIDCenters. In this model both the GC and the consultant participate in more than one center, namely Centers A/B, and A/C consecutively. Centers B and C could be offspring to Center A. The new network makes it easy to bind groups based on their contractual relations and reporting hierarchies. It does not have to be physically organized as shown in the figure, but accessibility and report protocols are controlled via this framework.

The proposed model (CPDIDCenter) communications hub or framework influences the design of the databases (i.e. the DMID: Chapter 5), and makes search and retrieval more attainable, because documents transacted between any center's groups are kept in that center, meanwhile remain accessible—via a web browser—to any other groups as well. CPDIDCenters are virtual generic moles, which could be replicated and regenerated as sub-centers to organize sub contractors. The CPDIDCenter framework is flexible to suit the evolution of any project and the changing delivery systems and organisations.

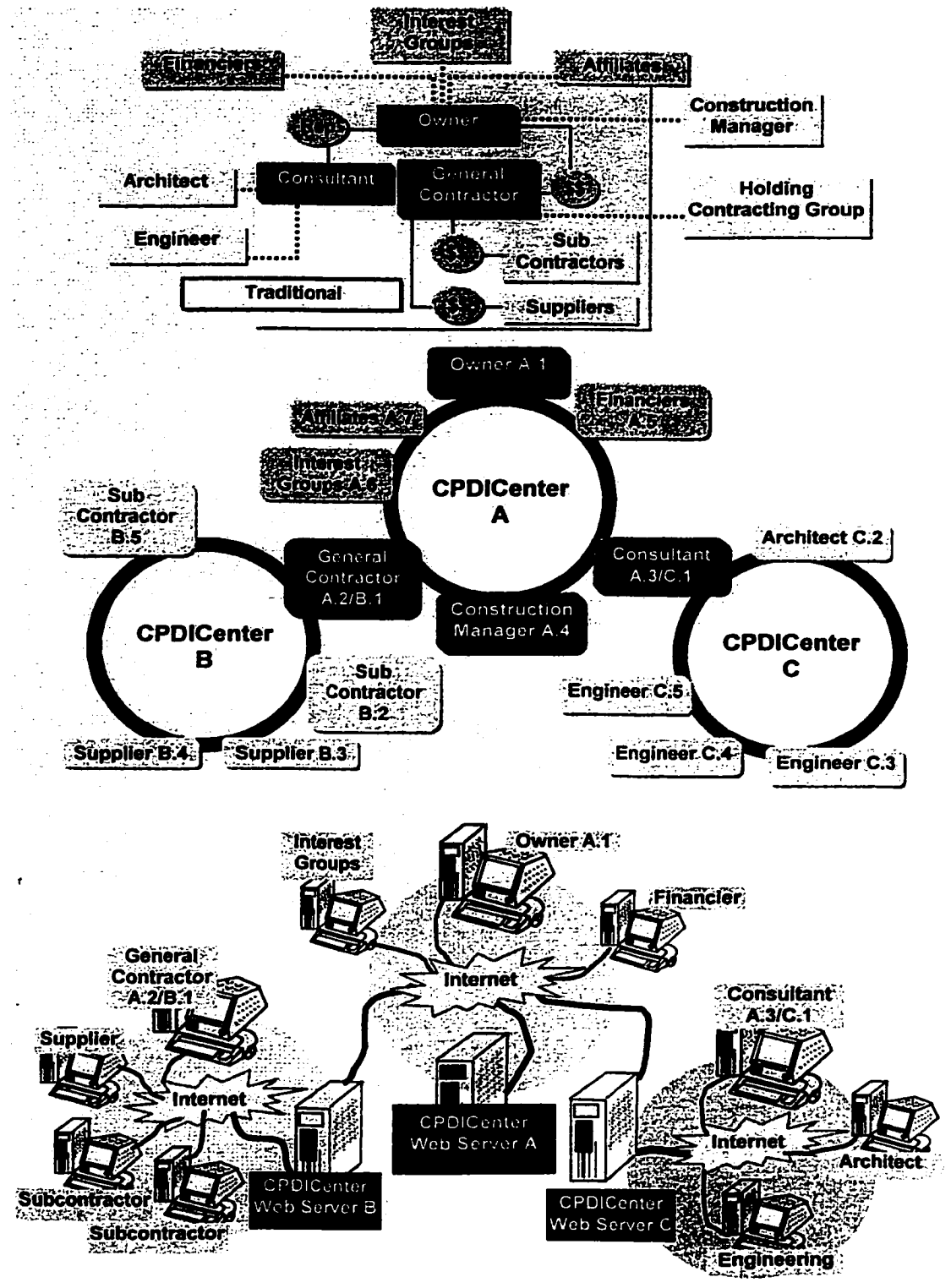

Figure-4.5: The Project Document Information Center Communications Framework

This framework works as a project-wide communications network that can be woven on the Internet, with access control vis-à-vis contractual agreements, and business rules [Hammad & Alkass 1999-b].

4.5.2 – Adapting the CPDICenter Various Project Organizations

Design-Build consortium

Referring to Figure-4.5, center C is detached from its interface with center A and reattached as a sub center of B. The general contractor continues to subscribe to both A and B as shown in Figure-4.6. This framework is easily replicated to streamline documents' workflow so that project groups will only relay and receive documents via those hubs.

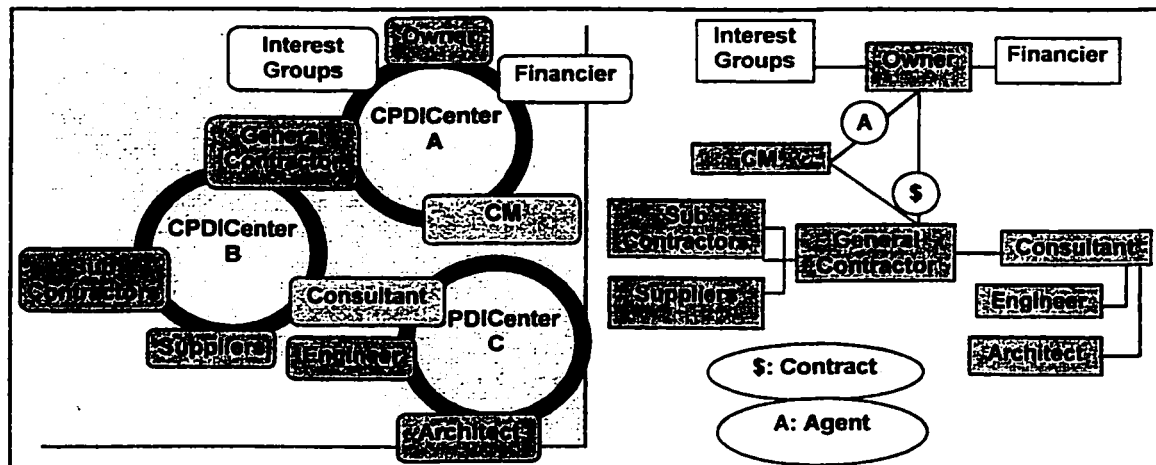

Figure-4.6: Adapting the CPDICenter to the Design Build Organization

Construction Management types

The committee on Construction Management [CCM 1987] surveyed various CM arrangements, amongst which two are enlisted here as an example on how the CPDICenter concept can be adapted to any Project delivery system.

Agency Construction Management

Agency Construction Management (ACM) means that the CM has a single role as an agent throughout the project, where the CM will not be involved in any other services to the owner. The CM is commonly a consulting firm with specialty in project scheduling, planning, risk analysis, procurement management, and project control. ACM delivery example and the matching CPDICenter architecture are depicted in Figure-4.7.

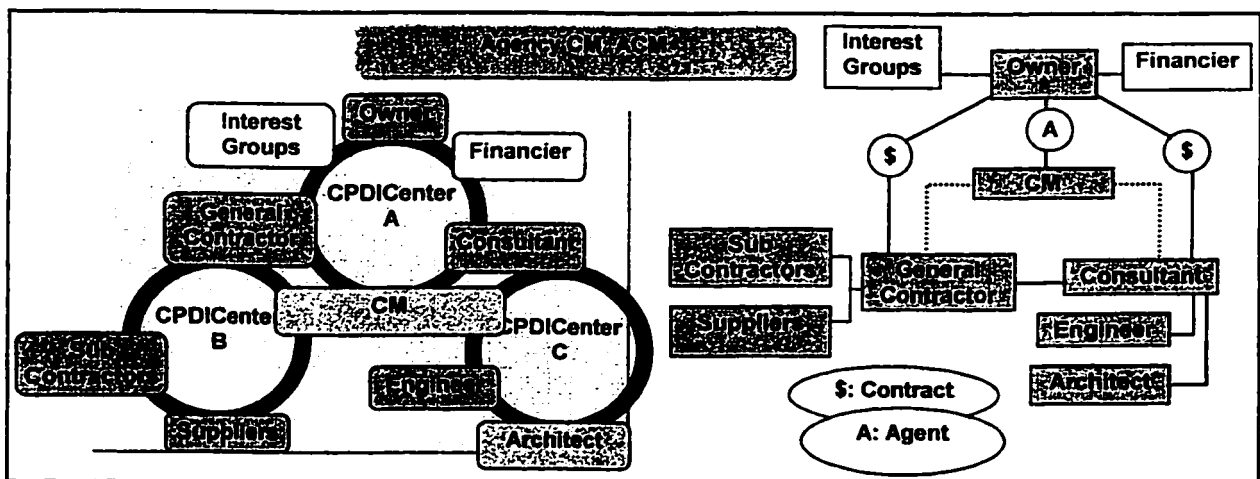

Figure-4.7: Adapting Agency CM to the CPDICenter Framework

Extended Services CM

Extended Services CM (XCM) permits the CM to play additional roles as architect, Engineer, or contractor besides his or her original role of CM. The CPDICenter adaptation of an XCM (Engineering) Architecture is shown in Figure-4.8, and XCM (Contractor) is shown in Figure-4.9.

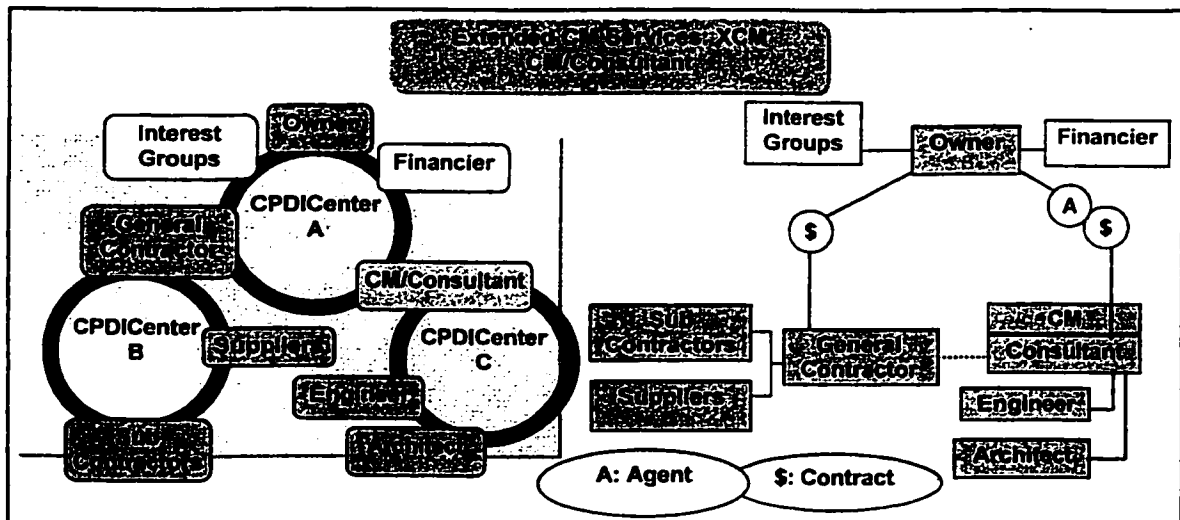

Figure-4.8: CPDICenter Framework Adapted to the XCM (Engineering) Organization

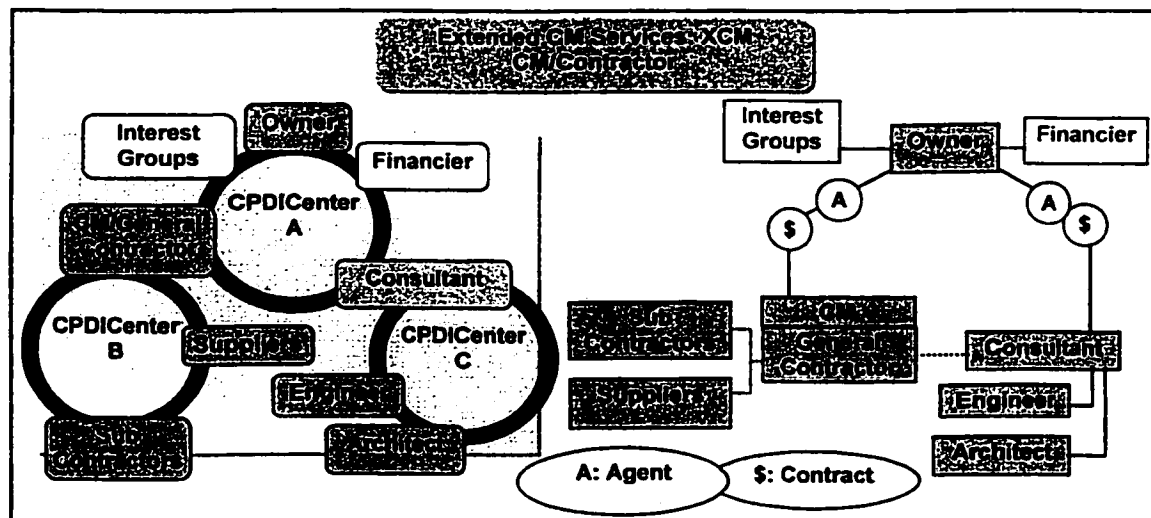

Figure-4.9: CPDICenter Framework Adapted to the XCM (Contractor) Organization

The CPDICenter is also adaptable to the EPCM (Engineering/Procurement/CM) services contract, as depicted in Figure-4.10. In such contracts, the CM/A/E (CM/Architect/Engineer) offers full pledged procurement, engineering, consulting, and management services to the client,

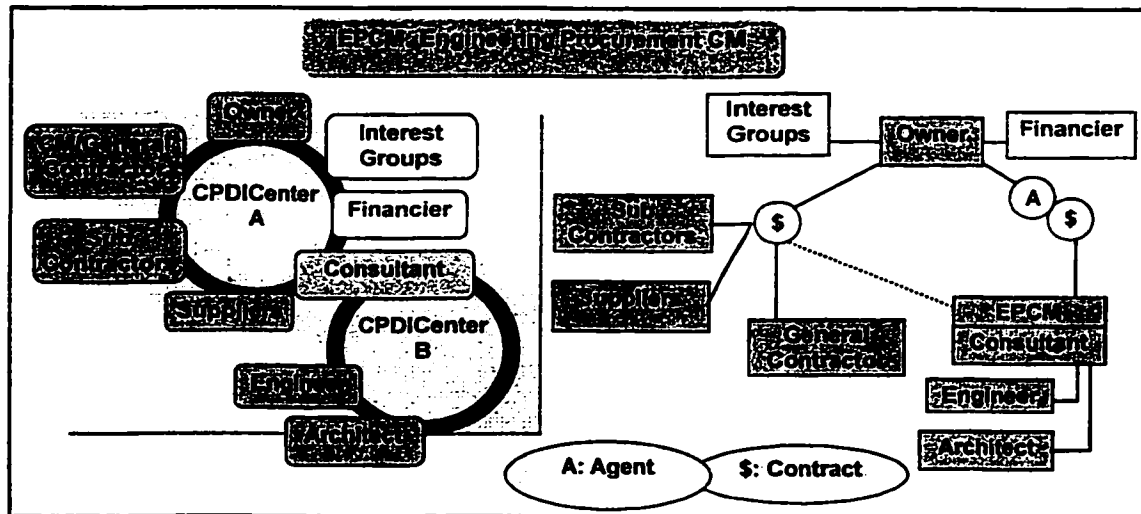

Figure-4.10: CPDICenter Adapted to the EPCMO Organization

4.5.3 – Features Of This New Framework

1. Lean and flexible architecture scalable to any number of project groups
2. Web-based collaboration framework adept to any documentation workflow
3. CPDICenters can be replicated, removed, and extended.
4. Enterprise-wide binder that gives all parties a common communications framework, and central document storage.
5. Creates a new baseline for project communications
6. Works for large-scale projects as well as small projects with minimum overhead to cover Internet server operation and maintenance.

7. Fits the distributed nature of project operations and sites over large geographical spaces.
8. Access to the CPDIDCenter will be through familiar web browsers.
9. Documents are submitted once to the system and are fused to every recipient and every Center.
10. CPDIDCenters host documents in central databases and saved at issuers' webfolders.
11. Helps plans the physical networking needs and locate servers, databases and computing resources.
12. . Can add or remove groups and centers as needed since relations are mainly programmable components added to the server. Offspring centers can also be introduced; in which case they still inherit required features from the parent Center. In general the framework works as a generic baseline.
13. The components of the center need not be at one location. Portions of the databases can be replicated as needed. Hence, the idea of the Center is of a logical connotation for organizing information and document folders and turning all that to the user as a unified searchable mass.

4.6 – CPDIDCenter website services & Components

A general breakdown of the CPDIDCenter website services (proposed functions, and search pages) and system components is shown in Figure-4.11. Main services include: 1) document registration and 2) document search facility. Table-4.1 also presents some key considerations when designing the CPDIDCenter's Architecture. For instance, Searching is possible by keyword (using predefined indexes) or with defined views that summarize claim issues or, by parametric search for specific documents given certain variables from the construction period in question.

Proposed components include: 1) file server, 2) messaging server, 3) search engine, 4) workflow engine to process document flows across the project. 5) DMID to hold information about every document and cross-reference it with project process information, and 6) server-side master webfolder for each group.

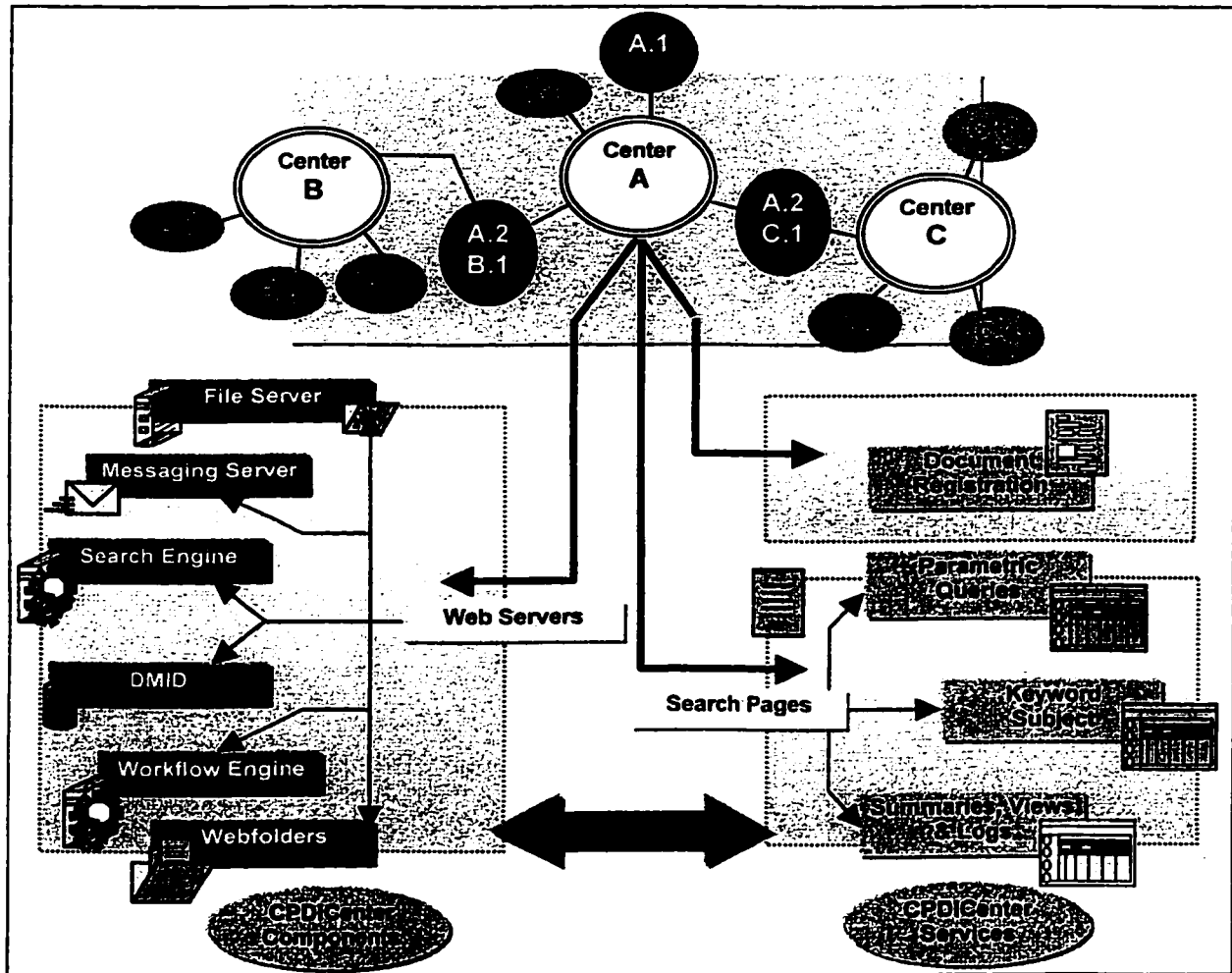

Figure-4.11: CPDIDeCenter Systems and Components WBS.

CPDIDeCenters are virtual communication hubs for project groups. This entails that fileservers and other Components of those hubs need not be at the same location. Further, project groups can keep their Webfolders (which hold their project documents)

at source with only links to documents inserted in the DMID at each Center. There is an amount of Webfolder replication necessary when a group such as the General Contractor shares in more than one center. Then it needs to locate a master Webfolder for every Center it participates in. The CPDIDCenter is web-based from the ground up.

Table-4.2: Key Consideration for the CPDIDCenter Framework

<ul style="list-style-type: none"> • Project delivery systems • Internet networking • Workflow design • Hardware components • Linking Databases with web forms. • Modeling User Cases 	<ul style="list-style-type: none"> • Parametric search • Keyword search • Subject search • Webfolder internal structure • Website organization • Document Registration forms • Summary Views 	<ul style="list-style-type: none"> • Claims documentation requirements • Document information Database model • Functional analysis of document flows • Project Subjects and Process Information • Validation tables for data integrity
---	---	---

4.7 – The Web Technology

The Internet more than ever is becoming the backbone for augmented and geographically spread set of partners collaborating together and need the elaboration of powerful frameworks to support their business models, concurrent enterprising, access to large corporate data sources and multimedia information management, within Intranets, Extranets and even the Internet [Zarli & Richaud 1999]. The Internet or the WWW is an excellent communications and information relay platform for project groups to access, and modify project information as easily as possible. It enables collaborative engineering, and also is transforming engineering business processes partly by new

standards for distributed applications and by Web-based data repositories that are coming to light and supporting more than ever new ways of running construction projects. Web technology builds on thin client-server architecture. Most browsers today use the MOSAIC platform, which was originally developed by the National Center for Supercomputing Applications (NCSA) at the University of Illinois, and taken to its full potential by IT companies. The forward nature of web technology is due to various appealing factors [Bernard 1998], such as:

- **Global access:** documents can be solicited from servers located anywhere on a global TCP/IP network like the Internet, or a private one like a LAN. This allows automatic download of remote documents.
- **Cross-platform connectivity:** browsers can all access the same core information on any OS platform.
- **Ease of use:** files are served seamlessly through a simple hypertext link. A web is a series of interlinked hypertext documents.
- **Flexibility:** WWW servers provide flexible interface to other applications, including online databases. Web clients may access different server types (Web, Usenet, gopher, ftp, mail...etc.) and can recognize any file type or format via its file extension.
- **Open standards:** any software that follows the published protocols—such as TCP/IP—can be used as a browser or editor.
- **Support:** Most web browsers already support spontaneous file capture or on-demand printing of information on local or networked printers
- **Advanced search engines:** Web-Bots and Spiders can map the contents of any document, and provide an interactive list of results to users.
- **SQL (Standard Query Language):** for database record and data retrieval is supported

4.8 – CPDICenter Information Architecture and Workflow

Internet networking is thin-layered client/server architecture. The client (Project group) interacts with the server via a browser and sends instructions to search and retrieve information from web databases and folders. As the Project organization becomes bigger, connectivity, interoperability, and data accessibility all become significantly expensive to maintain. Hence, the appeal of the Internet standard-based software and technologies like Adobe Acrobat® viewing tool, Java Script® for form processing, ASP® for database querying, those are attainable and inexpensive. The proper design of an information system should allow for immediate adaptation of current needs, and anticipate changes. If properly aligned, business requirements, processes and the conceptual framework of the information architecture become robust. The first obstacle in the design of the CPDICenter communications framework was to overcome the diversity in the project organizational structures—established thus far. Next steps are to detail the architecture of each CPDICenter and work out the document workflows.

4.8.1 – Highlights of the CPDICenter System Architecture

The proposed architecture is presented in Figure-4.12, in which the main layers/tiers and physical components are pointed. Project groups connect to the system via HTTP standard. Each group maintains a gateway server (link to the internet at group's offices and sites) that has a thin mail client (SMTP/POP3 compliant), web browsers, and other productivity software such as scheduling, CAD (Computer Aided Design), and spreadsheets. Groups having the capability can host DMID replicas.

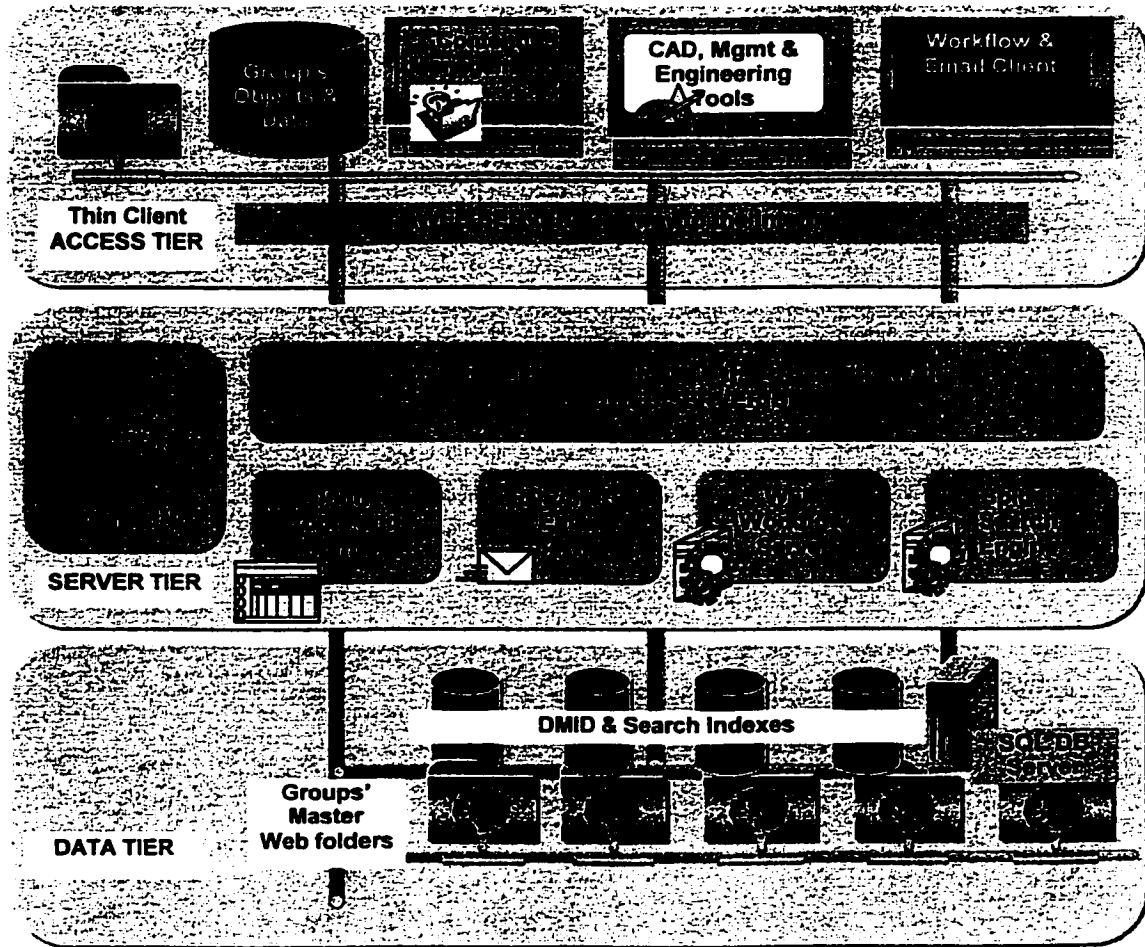

Figure-4.12: CPDICenter System Architecture

Each project group will also have two Web folders for every CPDICenter it participates in. They are:

- Local Webfolder at the user's side
- Master Webfolder within the CPDICenter

Webfolders have a global file/folder directory structure uniform across all groups. The CPDICenter's middle-tier contains: a) workflow server, b) mail or messaging server, c) file/content server and d) search engine. At the backend there is a data-tier where

project process data, documents' information and search indices all reside. SQL Servers, and RDBMS (Relational Database Management System) servers are suggested to manage metadata. Project Documents—from all groups—are maintained at two sites: 1) the master Web folders in each CPDIDCenter hub, also at the authoring group's local webfolder. Other instances of a document may exist, simply because documents are sometimes distributed to various recipients. However, only original documents count to the final tally. Metadata is information about data, and can be something similar to: who received a certain document, when it was issued? where it was stored?, and which activity is reported in that document? An open text search engine—at the services tier—is proposed to scan each new document and appends its entry to subject and keyword indices. Integration of the database server with email (SMTP) and Webfolders is possible via a Lightweight Directory Access Protocol (LDAP). LDAP is a protocol for accessing online directory services. It runs directly over TCP/IP, and can be used to access a standalone LDAP distributed directory service over the Internet, or accesses a directory service that is back-ended CPDIDCenter document Indices (see Chapter Six) are integrated to offer a more comprehensive search by keyword and subject searches.

4.8.2 – CPDIDCenter Workflow Highlight

A sample document workflow inside the CPDIDCenter is demonstrated in Figure-4.13. Members of the group collaborate and produce project documents of all types (extensive list of project document titles and CPDIDCenter document Classes are available in Appendix A).

Members can access their portals inside the CPDICenter at addresses similar to: [http://groupID.CPDICenterX.project_name.com]. They can also register and classify their documents by filling a DMID registration form.

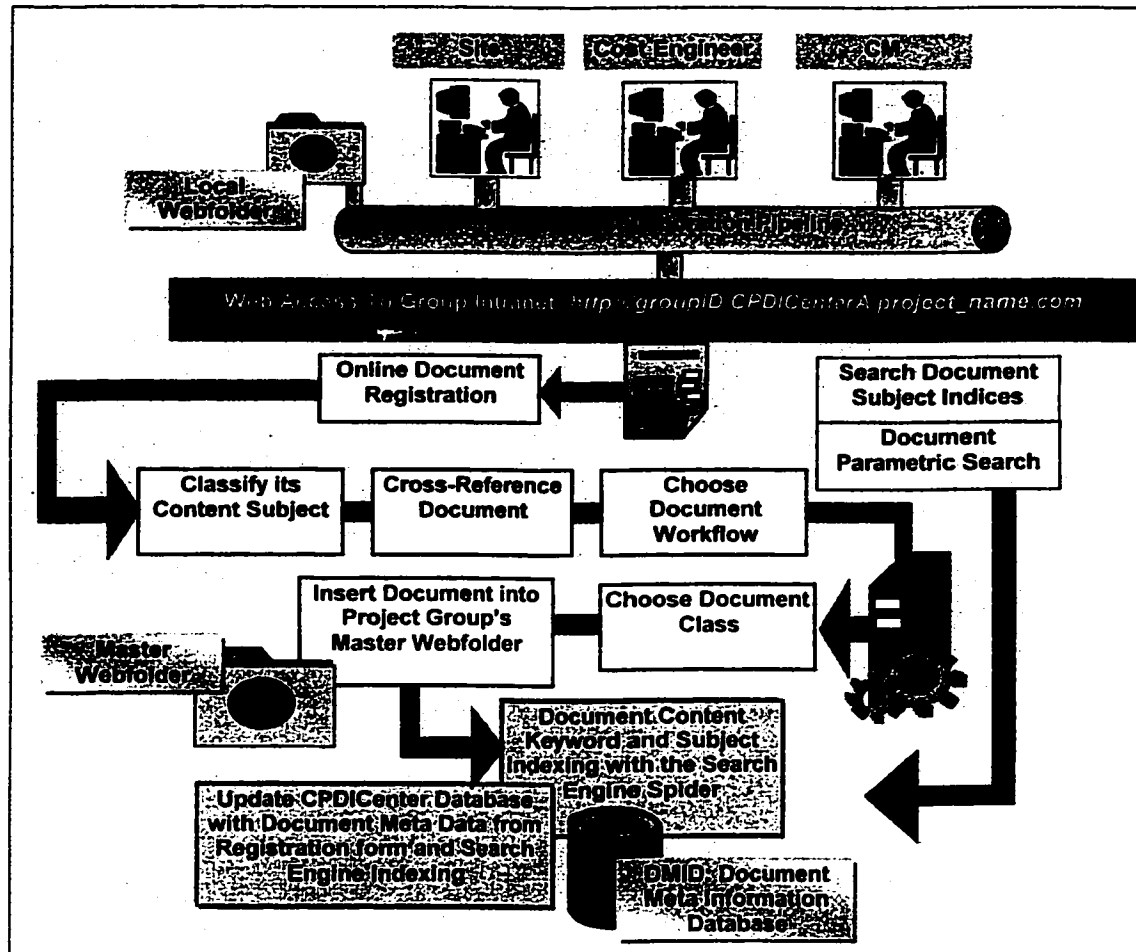

Figure-4.13: CPDICenter Document Registration Session Steps.

Registered documents are processed through the system, and inserted into the Webfolders (local and master) of the group. The classification of the documents is a profiling technique to get them enlisted with all relevant search indices.

Document registration inside the CPDIDCenter has four steps, as shown in Figure-4.14, after which the user can view the new document entry in the DMID for correction, or addition, or change to the classification data.

The figure illustrates the four steps of document registration in the CPDIDCenter. The first three steps are form-based data entry screens. The fourth step displays the results of the registration in a table format, with a callout box indicating that the results are presented directly from the database.

Doc ID	Doc Title	Doc Type	Doc Status	Doc Date	Doc Author	Doc Editor	Doc Reviewer	Doc Approver	Doc Classifier	Doc Indexer	Doc Searcher	Doc Reporter	Doc Auditor	Doc Manager	Doc Admin	Doc User	Doc Group	Doc Role	Doc Permission	Doc Action	Doc Result
1	Doc 1	Doc Type 1	Doc Status 1	Doc Date 1	Doc Author 1	Doc Editor 1	Doc Reviewer 1	Doc Approver 1	Doc Classifier 1	Doc Indexer 1	Doc Searcher 1	Doc Reporter 1	Doc Auditor 1	Doc Manager 1	Doc Admin 1	Doc User 1	Doc Group 1	Doc Role 1	Doc Permission 1	Doc Action 1	Doc Result 1
2	Doc 2	Doc Type 2	Doc Status 2	Doc Date 2	Doc Author 2	Doc Editor 2	Doc Reviewer 2	Doc Approver 2	Doc Classifier 2	Doc Indexer 2	Doc Searcher 2	Doc Reporter 2	Doc Auditor 2	Doc Manager 2	Doc Admin 2	Doc User 2	Doc Group 2	Doc Role 2	Doc Permission 2	Doc Action 2	Doc Result 2
3	Doc 3	Doc Type 3	Doc Status 3	Doc Date 3	Doc Author 3	Doc Editor 3	Doc Reviewer 3	Doc Approver 3	Doc Classifier 3	Doc Indexer 3	Doc Searcher 3	Doc Reporter 3	Doc Auditor 3	Doc Manager 3	Doc Admin 3	Doc User 3	Doc Group 3	Doc Role 3	Doc Permission 3	Doc Action 3	Doc Result 3
4	Doc 4	Doc Type 4	Doc Status 4	Doc Date 4	Doc Author 4	Doc Editor 4	Doc Reviewer 4	Doc Approver 4	Doc Classifier 4	Doc Indexer 4	Doc Searcher 4	Doc Reporter 4	Doc Auditor 4	Doc Manager 4	Doc Admin 4	Doc User 4	Doc Group 4	Doc Role 4	Doc Permission 4	Doc Action 4	Doc Result 4
5	Doc 5	Doc Type 5	Doc Status 5	Doc Date 5	Doc Author 5	Doc Editor 5	Doc Reviewer 5	Doc Approver 5	Doc Classifier 5	Doc Indexer 5	Doc Searcher 5	Doc Reporter 5	Doc Auditor 5	Doc Manager 5	Doc Admin 5	Doc User 5	Doc Group 5	Doc Role 5	Doc Permission 5	Doc Action 5	Doc Result 5

Figure-4.14: CPDIDCenter Document Registration and Indexing Steps.

Registration intends to profile every document and for that it solicits form the project member information such as:

1. Subject of document contents
2. Document cross-references
3. Document workflow
4. Document class, category, title and Webfolder directory
5. Document content keyword and subject for search indexing
6. Claim information and problem (if any), and keywords.
7. Paper trails, and other documents associated with the registered document.

4.9 – CPDICenter Document Classes and Web Folders

4.9.1 – Document Storage Requirements

Documents' sprawl to various project locations without discernable directory structures complicates maintenance functions for backing up and archiving files. A storage architecture is required that ensures access to documents for all groups of the project organization. The necessary Webfolder structure will define where and how to store documents. Quintessentially, this structure defines which cabinet (i.e. file/server) a document belongs to. Storage management routines should enforce storage of documents to centralized storage locations. This will simplify maintenance functions for backing up files. Webfolders with preset folder tree structures, mapped according to the document classification discussed earlier, are distributed to all project groups. Each group owns two webfolders, one in-house (client side or local) and a master folder kept at the

CPDICenter's server, as shown in Figures-4.12, and 4.13. When a new document is created, it is inserted in the proper directory at the client side with the workflow instructions pertaining to the claim issue at hand. For example, a document workflow log would include steps for distribution, notice of delivery, annotations, reviews, holding period, reply period...etc. After documents are created, services are required to eliminate the burden on project groups and their members for determining where they should be stored. The user of the CPDICenter stores a document based on specific information about the group creating it, cost account it belongs to, the workpackage, and the business process category it supports. This makes retrieval based on meaningful parameters, and keywords that describe the contents of a document and its association to other events or documents in the project, instead of having to know the cryptic server\volume or directory\filename naming methods in order to retrieve documents.

4.9.2 – Document classes

Documents can be classified in numerous fashions based on the selected view or subject. To promote consistency amongst all participants, documents in this research are classified into four Classes: A) Transactions, B) Proprietary, C) Public, and D) Definitions [Hammad & Alkass 2000-c]. This classification has guided the development of a scheme to collect, and manage the storage and retrieval of project contemporaneous documents. Transactions are documents transferred from one group to another in the project, and they include: correspondence, shop drawings, payment requests, requests for information, and claims. Public documents, include: master schedules, financial statements, warranties, licenses, bonds, permits, labour agreements, and environmental

assessments. Public documents are published to all project members as part of the project review and follow-up routines. Proprietary documents include: internal site memos, site instructions, method descriptions, patented plans or product model schemas, internal quality audits, cost tracking reports, and expert opinions. Access to proprietary documents is limited to the group issuing them. Definitions include: bid invitations, addenda, warranties, standards, codes, product models, communication procedures, control structures like WBS, contract clauses, and contract changes. Definitions are used for guidance and for auditing project requirements according to agreements. An extensive list of every class document categories and titles is available in Appendix A. This classification carries connotations about access rights. This classification is also as shown in Figure-4.15, in terms of the level of document sharing and the project stage.

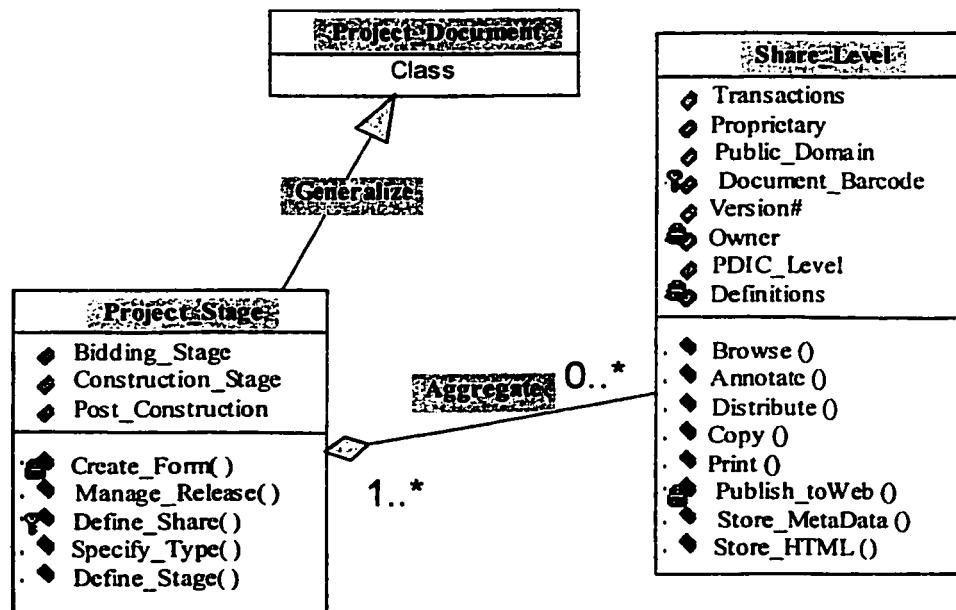

Figure-4.15: UML Model of the CPDICenter Document Classes

For instance, a proprietary document registered and mapped by the CPDIDCenter's database, is accessible only by the group that issued it. On the other hand, everyone in the project shares documents of Class Public. Transactions, have limited sharing policy, which limits access to only the groups that issued the document and/or the ones on the distribution list (i.e. marked recipients). On the other hand, a document of Class type Definitions is shareable by the groups that are in contract with each other's. Almost every document title (title: name of subject matter the document is issued for and usually in concordance with a prevailing contractual clause which pertains to a specific issue, event, or claim at hand) can be classified into one or more of those aforementioned classes. Document collection starts from the bidding stage. Therefore, all bidding documents and addenda are included, along with documents from the various construction periods, including close-out and de-commissioning of the project components or facilities to the client. Some examples of documents from Class type Transactions are presented in Table-4.2. Those documents are further classified into: Bidding, Construction, and Post construction Stage documents—see Appendix A.

Table-4.3: Sample Transaction Documents for all Stages of the Project.

Bidding	Construction	Post
Tender documents	Requests for Information	Completion Certificates
Soil tests	Plans and Drawings	Claims
Performance Bonds	Change Orders	Payment Requests
Addenda	Changes	Release of holdbacks
Milestone Schedules	Schedules	Liens
Specifications	Payment requests	Inspection Reports

4.9.3 – Document Webfolders Design

Documents are published to the webfolders of the group that created them as shown in Figure-4.16. Documents inherit attributes from the directory/subdirectory location they are inserted into, and this makes a logical as well as a physical inference with each document.

For example a Drawing may be released as part of any WBS or Workpackage and stored in New Plans or Work Drawings sub folder, yet is cross-referenced to any C.O. or Delay Issue in the project. This plan has to be referenced in the database as part of an ongoing change order issue, and its physical location designated, also as part of specific workpackage or contract. Hence, a Plan is part of a WorkPackage, a cost account, also related to an Issue (claim), a construction event, and of category Drawings. Other logical affinities are possible, as needed.

This way a document is stored once, and cross-referenced as needed. Figure-4.16 illustrates in detail the structure of each Webfolder in the CPDIDCenter for a sample traditional project organization. Webfolders' file directory structure is uniform across the project, and each group has two folders (local and master) for every CPDIDCenter it is in.

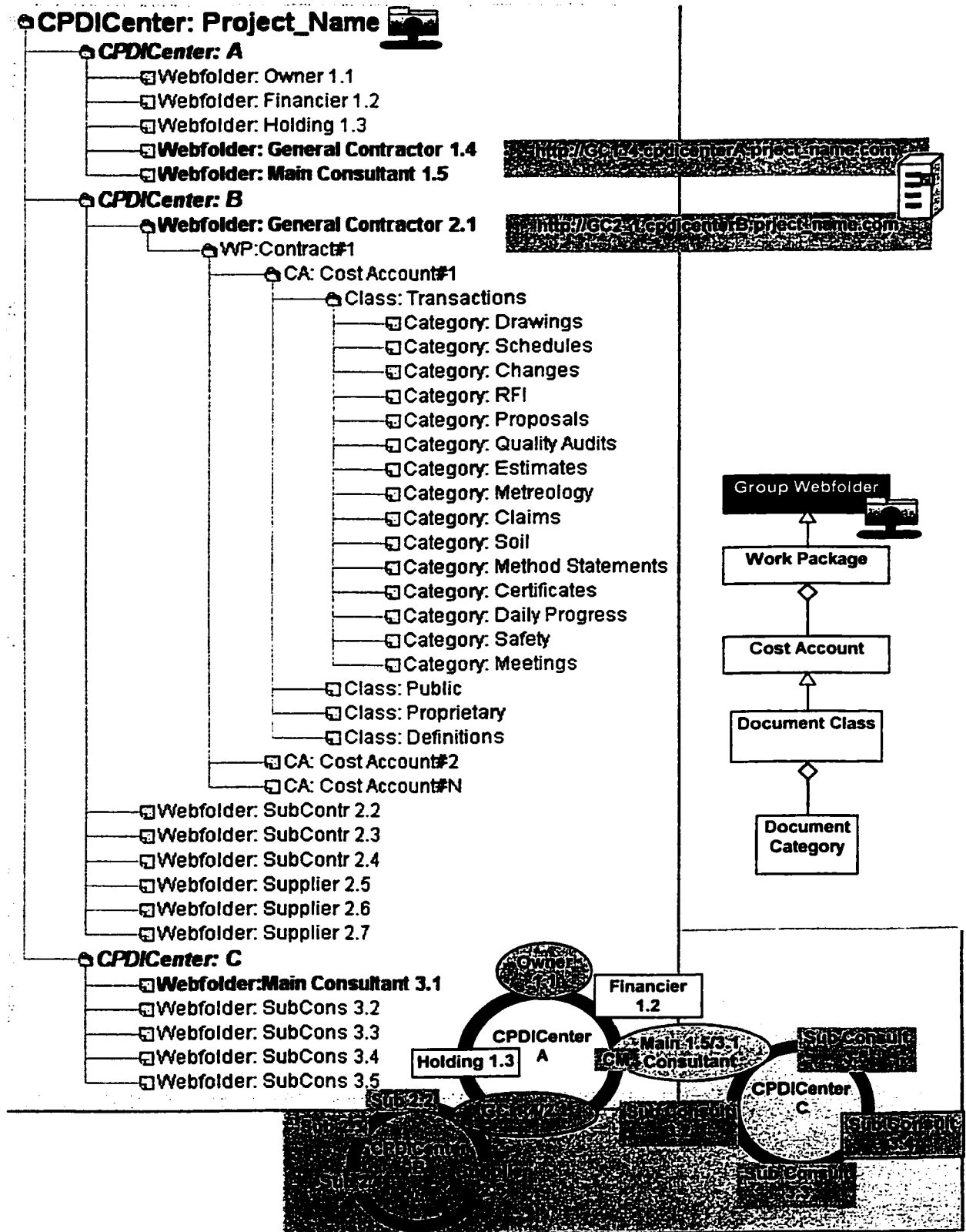

Figure-4.16: Webfolder Structure for a traditional Project Organization.

4.10 – Standardizing The CPDIDCenter Development

The CPDIDCenter development extends in the next chapters to include the development of the DMID, and website search pages and indexes. The development effort can be made systemic as charted in Figure-4.17, which is an idealization of a systems approach to consistently reproduce the same CPDIDCenter framework. However, implementations can divert in sub-issues as per industrial requirements. The focus in this research, for instance, was to allow post construction claims analysis the best chance of locating and retrieving project history. The systems approach follows the IDEFØ (listed in Chapter Three and notation explained in Appendix-B) modeling principles, and semantics. It establishes CPDIDCenter as a manageable function with four elemental sources of information or data. The elemental parts are:

- 1) **Input:** data, process outputs, analyses, and knowledge of project facts.
- 2) **Output:** which will feed into a dependent process/function, or merely data for management.
- 3) **Mechanism:** rules of business, requirements, or limitations.
- 4) **Tools:** software programs to aid or assist in achieving the results.

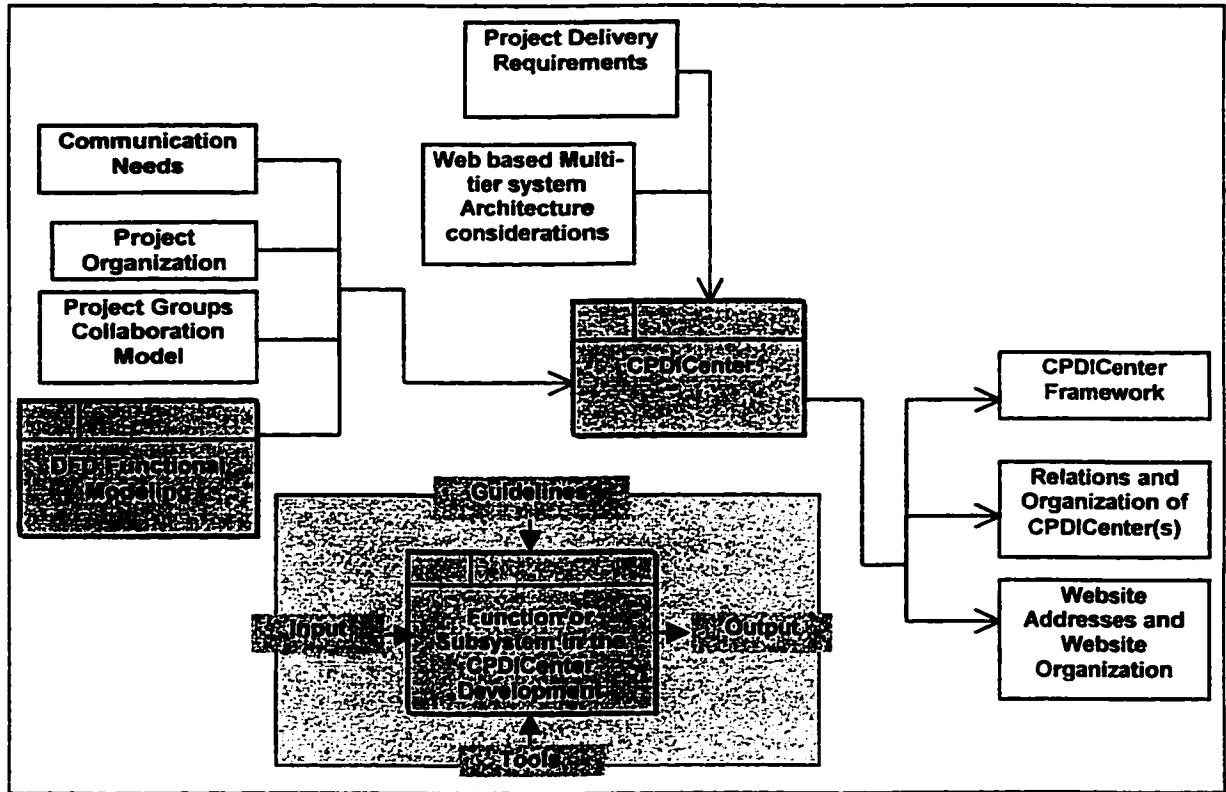

Figure-4.17: Systems Approach for Developing the CPDICenter.



Chapter Five *Implementation of the CPDIDCenter Web Document Meta Information Database*

5.1 – Purpose and Mission of the DMID

This chapter lays the ground for the design of two main components in the CPDIDCenter, namely: the DMID, and the CPDIDCenter Website search views. Modeling the relation between documents, claims, and project process information will establish potential database views and document summary logs to post on the website. Moreover such classification of information is needed to structure the website pages and organize its contents or search forms.

Since any document can be recalled in a claim analysis situation, the database design and website takes this into consideration when designing the views, queries, and table structures, to maximize the reach of documents' information, so project groups can access them from just about anywhere. To that end, summaries about different documents' subjects, types, related tasks, and persons involved, should be presented immediately once documents are published to the CPDIDCenter's website. Web databases are suitable because they hold updated data. Database queries should be automated through self-explanatory menus that issue a query and produce reports at the click of a button. What is needed are feasible means for maintaining and accessing groups'

documents and process information at any stage of the project starting from the bidding period. Hence, once an owner is ready to invite bids to a project venture, then the CPDIDCenter and its components especially the DMID should be up and running. If contractors bid online that would make document form processing much faster. Conceptual schemas used to structure document data would provide a basis for developing a logical relational database design.

5.1.1 – CPDIDCenter DMID Benefits

The creation of a project-wide document metadata service addresses the need for a central place to create and manage all document metadata according to business rules (e.g. what to document? and who should document? or how to process a change order?). With metadata services, models can be created to cover all project groups and their project documentation. The result is an accurate and consistent document data view across the enterprise, and a common information model of documents' issuance context.

This is accomplished through a three-tier architecture (proposed earlier for the CPDIDCenter system architecture in Chapter 4) that isolates the documentation business rules from the data sources and the end applications. The service compiles documents' data from a variety of sources: 1) web document registration forms, 2) contextual data pertaining to document location in a group's Webfolder, 3) project site, 4) contract clauses, 5) document type/category/class, and 6) tasks affiliated with the document. The database model better have dimensionality in its schemas (e.g. snowflake shape, or hierarchical) because in complex ER models it makes information easier to understand,

query, and resilient to change. For example, data about a group member or activity, or a cost account is defined once and made available for many uses. The DMID utilizes basic data assets for instance: activity details, WBS, cost accounts, resource particulars to identify documents with. The DMID contains subject-oriented tables optimized for searching; data can be accessed the way project members or claim analysts might expect; for example by affiliating a document with an event, a site, an activity, resources, construction components, extras and changes, contract changes, entitlements, causes, document types, or contract package.

5.2 – What is a Web Database?

5.2.1 – The Location of the DMID

As shown in Figure-5.1, each CPDIDCenter houses a DMID on the server side, so that project groups can all access it via a browser and locate documents or register new ones. On the other hand, if the number of project groups is limited, then all CPDIDCenters can be served by one DMID. As the number of groups increases—thus increasing the intensity of document flows—the DMID structure can be replicated.

5.2.2 – Replication

Only the logical design of the database is replicated across all the CPDIDCenters, while document files are not replicated since they reside in groups' Webfolders. Web servers are responsible for transporting documents to users upon filling a query form. Documents can be backed up in persistent forms (Compact Disks). The DMID structure

is scalable to any number of document records, users, project groups, sites, and project activities. Moreover, partial replication of the DMID is possible.

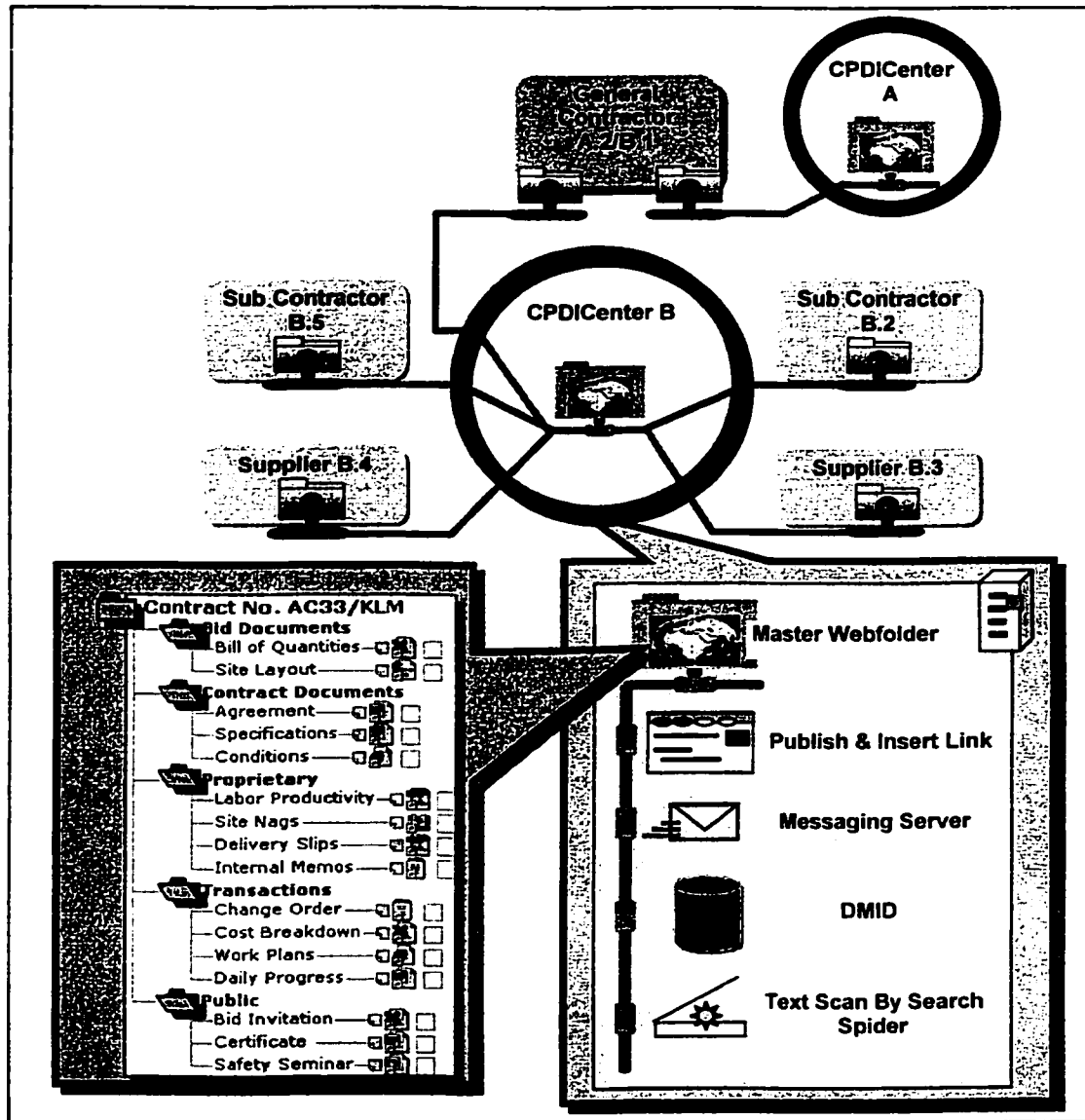

Figure-5.1: CPDICenter Group Webfolders and System Components

5.3 – Development Environment and Technology Preview

The ability to publish forms, which rely on database tables and queries, is a critical development for the Web. Publishing those forms requires an HTML (Hypertext Markup Language) layout control on the user's workstation. The approach used here implements recent Microsoft® Web technologies, specifically: Active Server Pages (ASP). That relies heavily on ActiveX® for control, and Dynamic HTML (DHTML). ASP utilizes VB Script® or Java Script, and can be executed either at the client's side or the server's side. One can use a limited amount of ASP scripting within the HTML tags to create forms on the Web to reference databases [Corning et. al. 1997].

This approach does not require anything special on the desktop workstation. Any browser that can read an HTML form can interact with a relational database. The ASP approach is a server-bound technology, which makes it potentially slow because it can force trips back to the server just to look at a single new Recordset. But with the use of DHTML, that problem is eliminated since DHTML data binding functionality enables developers to retrieve records lists from a server to a user's workstation, and lets the user navigate around the records without traveling back to the server.

In addition to defining document types, as most document management products do, documents can be grouped when submitted to the CPDICenter based on project or group attributes defined by the user. For example, engineering change order drawings have certain attributes that categorize them according to the site, construction package, structural element, cost item...etc. This entails creating more table fields in the

underlying RDBMS (Relational Database Management System). Sharing data on the Web is commonly carried out with static HTML format, and that serves well its purpose when the data does not change frequently and outputs in the form of a report or a datasheet is only a snapshot of the data at the time it was published. In the CPDIDCenter, project groups are supposed to see updated reports and summaries of all document information as new documents are inserted into the database and published. In order to avoid republishing all this information on every update the CPDIDCenter deploys DHTML, which does not require republishing output views of the database to see data changes, because data is accessible in real time. Unlike static HTML, DHTML files do not start out as pure HTML files, instead ASP format is used to create outputs of datasheets and forms. In essence, a Web server processes these files and initiates a dynamically constructed HTML file back to a Web browser.

5.3.1 – The Web-Database Interaction Technology

The process of getting a full-fledged database on the Web requires three essential components: 1) database, 2) Web server, and 3) application server to join everything together, as Figure-5.2 suggests. There are interfaces between all three possible pairs as well as the interaction between all three components. The two right angle arrows that face each other, point to the Web database technology necessary to bring static data alive on a user's browser. Between both the web server and the web application server there is the Web server API (Application Protocol Interface), which amid the database and the web application server has to define a database driver protocol like ODBC (Open Database Connectivity), or any other database connectivity protocol native to the

RDBMS. Some Web Development Applications combine several of these components into a single package. Essentially the database is a set of organized facts related to each others based on prevailing project claims and construction management practices.

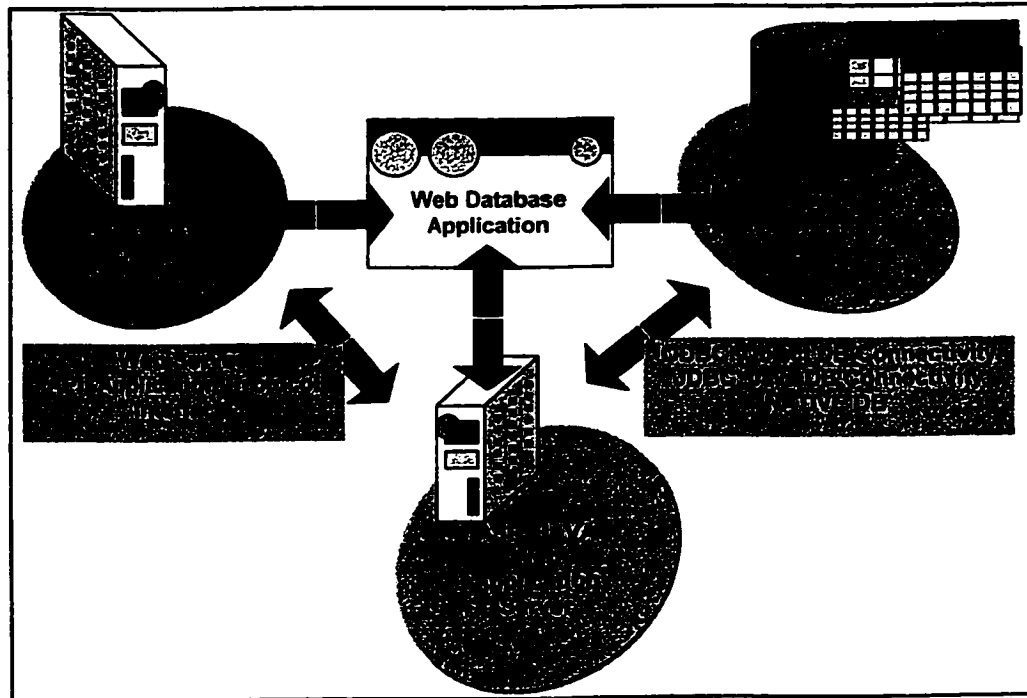

Figure-5.2: Technology Used in Joining the Web Server, and DMID

5.4 – Scripting and Client-Server Communication

The Interaction between client and server, and the ASP code implementation is described hereinafter in stepwise sequence in Figure-5.3:

- A.** A request is made from the Web browser to the server for the ASP file.
- B.** The server parses the ASP file, to execute any SQL statements, connection information, and field value placeholders.

For the Datasheets or database reports and views:

- C. VBScript code opens the database using ODBC (Object Database Connectivity) database Driver and the ASP file connection information, and runs the query in the ASP file to access the data.
- D. The Internet server sends the HTML file back to the client's Web browser for display as a Web page.

For database forms:

- E. The Browser loads the HTML Layout Control (Active X™), which is used to position the form fields and other controls on the HTML page.
- F. Browser requests a supporting ASP file (called **objectname_alx.asp**).
- G. Supporting ASP file is read by the Server component.
- H. VBScript code opens the database using the ODBC Driver and the ASP file connection information, and runs the query in the ASP file to access the data.
- I. VBScript responds with the data and the supporting ASP file

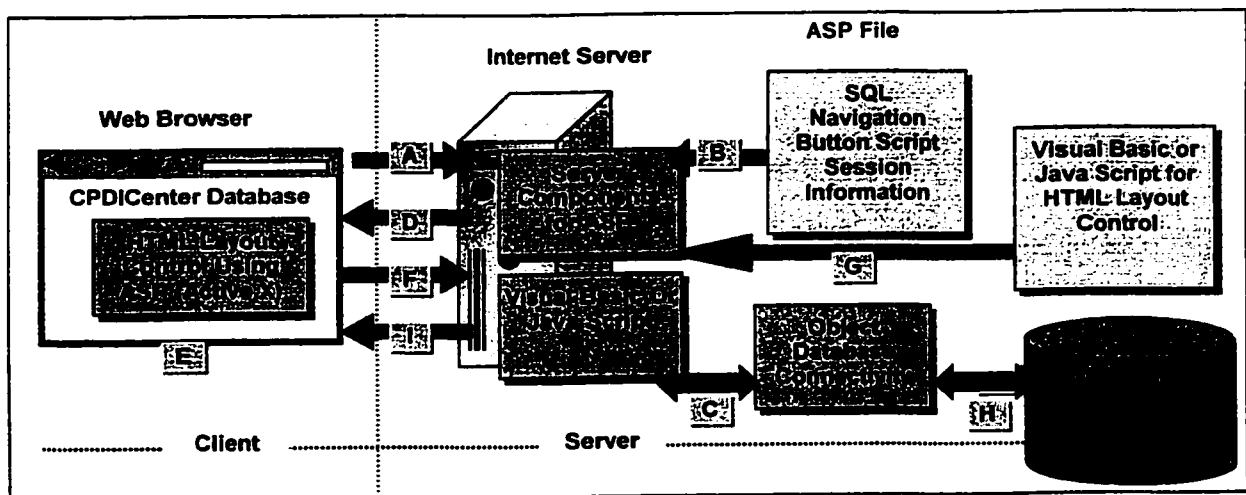

Figure-5.3: Database Client Interaction using ASP (Active Server Pages) and VBScript

5.5 – Connecting to DMID Web Database

Technology for connecting to the DMID via a web browser is ActiveX Data Objects (ADO). ADO is a set of objects that can connect to any ODBC (Object Database Connectivity) or OLE (Object Link & Embedment) database [ADO 2000]. ADO is arranged into an object model; in this case the root object is typically the Connection object.

5.5.1 – Linking to the ADO Library

Accessing external components is via a reference to the ADO library. As an example, the following ADO connection object is created in ASP:

```
Dim Conn As ADODB.Connection  
Set Conn = ADODB.Connection.Open("Provider=SQLOLEDB;Data Source=SomeServer;User ID=sa;Password=;")
```

Once a Connection object is established queries could be run on the database using the Execute method, for example:

```
Dim SQL As String  
SQL = "SELECT * FROM Customers"
```

In this case Active Scripting (the Microsoft technology that interprets and runs the VBScript code embedded in ASP scripts) evaluates if the Connection object supports the Execute method, then checks what parameters the Execute method supports. That operation happens whenever a method or property are called to run on an ActiveX object created inside ASP, irrespective of the language being used. Similarly it happens in Visual Basic whenever methods are called to run on objects that Visual Basic (VB) doesn't recognize. The main difference between VB and VBScript/Active Scripting is

that VB is a compiled language that calls an object in one step, while VBScript/Active Scripting is an interpreted language that has to move through a higher-level architecture.

5.5.2 – Providing Data Services

To support the CPDICenter's search facility, a class module (Database) has to be created in order to provide data services to the rest of the objects in the model—the database is an infrastructure object. Data services encompass actions like selecting rows, inserting or deleting records, and schema manipulation. ADO is at the core of those services, and provides a set of database functionality. Database object (ADO) is implemented to connect to the database and let other objects as well get a connection to the database without having to chart separate connection details for every object.

5.5.3 – Adding Records to the Database

The database is manipulated using ASP through an ADO. ADO is a set of pre-made data components, which makes it easier to access data records in the tables. Via ASP, the ADO can also add records to a database either by using Connection Objects, or Recordset Objects. Both record adding options are explained hereinafter.

Adding Records to The DMID Via A Connection Object

It is the easiest and fastest way to add records to a relational database. Table-5.1 presents the code listing showing how the connection object is used with ASP to add records:

Table-5.1: Sample ASP code explaining how to add records using Connection Objects

```
<%
' Setting variables
  Dim con, sql_insert, data_source

'DSN stands for Data Source Name
  data_source = myDSN
  sql_insert = "insert into books (author, title)
values _
              ('Mamoon Hammad, 'Adding Records')"

' Creating the Connection Object and opening the
database
  Set con = Server.CreateObject("ADODB.Connection")
  con.Open data_source
' Executing the sql insertion code
  con.Execute sql_insert
' Done. Now Close the connection
  con.Close
  Set con = Nothing%>
```

This results in the creation of a Connection Object, which opens the database and inserts the records into specific fields of the table according to the SQL (Standard Query Language) insert statement.

Adding Records to The DMID Via Recordset Object

Recordset is another very useful Object, which allows the selection; addition, update and deletion of records without using SQL reserved statements. Table-5.2 explains how to add records with Recordset Object.

Table-5.2: Sample code for database connection using Recordsets

```
<?
' Setting variables
Dim rs, data_source
data_source = myDSN

' Creating Recordset Object and opening the database
Set rs = Server.CreateObject("ADODB.Recordset")
' Lets open books table
rs.Open "books", data_source
rs.AddNew
' Now adding records
rs("author") = "Faisal Khan"
rs("title") = "Adding Records"
rs.Update
' Done. Now Close the Connection
rs.Close
Set rs = Nothing
?>
```

SQL INSERT statement is not used in Recordset approach. In general the Connection Object is faster and uses less server resources while Recordset Object is resource heavy.

5.6 – Claims Information Classification and DMID Design

Earlier in the thesis the concept of using procedures and claims management business rules for Documentation was presented. Those procedural guidelines can show how to communicate founding policies, forms of agreement, meeting minutes, project guidelines, and legal guidelines [Kerzner 1998].

Such procedures also help establish uniformity, encourage documentation, standardize data format, and unify teams. [Pruitt 1999] found that, to control change first step is to layout or model the change procedure that will be used in implementing that

change, and then evaluate its results. Two UML models, shown in Figures-5.4 and 5.5, are developed in this thesis to link project contracts, process changes, and events from the construction operations and documents. Figure-5.4 relates documents to their storage directory in the Webfolders, and to contract clauses and control data.

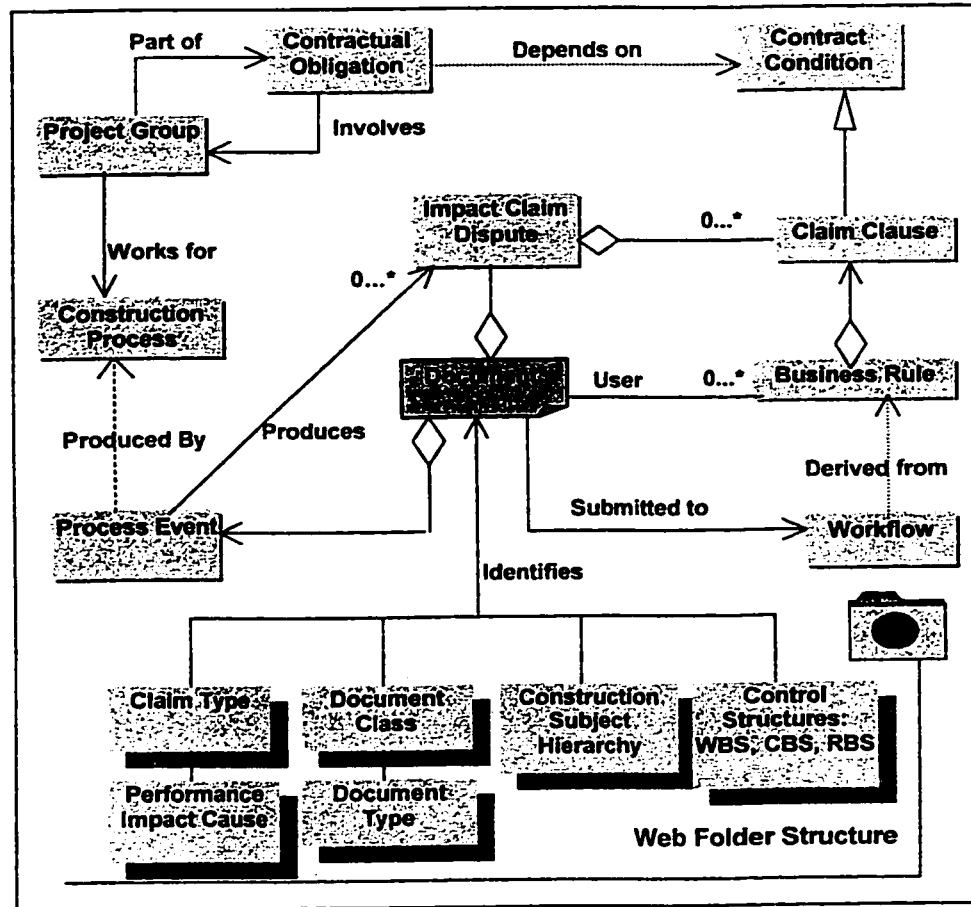

Figure-5.4: Document UML Model linking documents to process information subjects

Figure-5.5, on the other hand, depicts a model of the Change Management Information and its relations to documentation, construction processes, WBS, and project groups. Notations and constructs for all modeling languages used in this thesis are presented in Appendix-B. CPDICEnter's document classes, and categories, along with

sample contract clauses, and conditions, are presented in Appendix A.

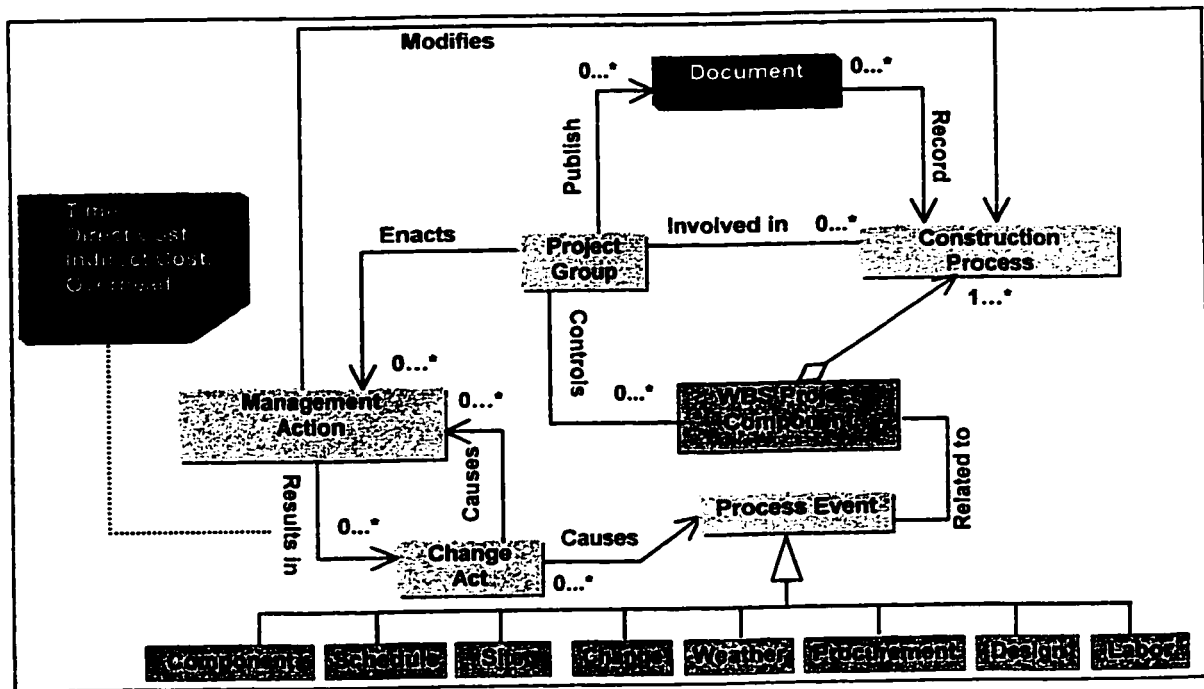

Figure-5.5: UML Model Linking Documentation and Change Management.

5.7 – Functional Modeling and DMID Design

To account for any impact a change might cause to a project’s cost and schedule, an accurate history of events should be compiled and maintained for any claims analysis. Such procedures are initial maps or models for document workflow automation, and it is necessary to standardize contract change procedures for that matter. Defensive claims management practices encourage keeping track of the status of especially precarious activities. Continuous collection of information such as plan revisions, design versions, method changes, site planning, productivity issues, and submittals serves that end.

A case of design change depicted in Figure-5.6, is modeled using functional modeling charts (DFD) of document movements amongst management and operational functions. This aids in the design of the ER model and understanding documentation needs, as well as documentation production in the system.

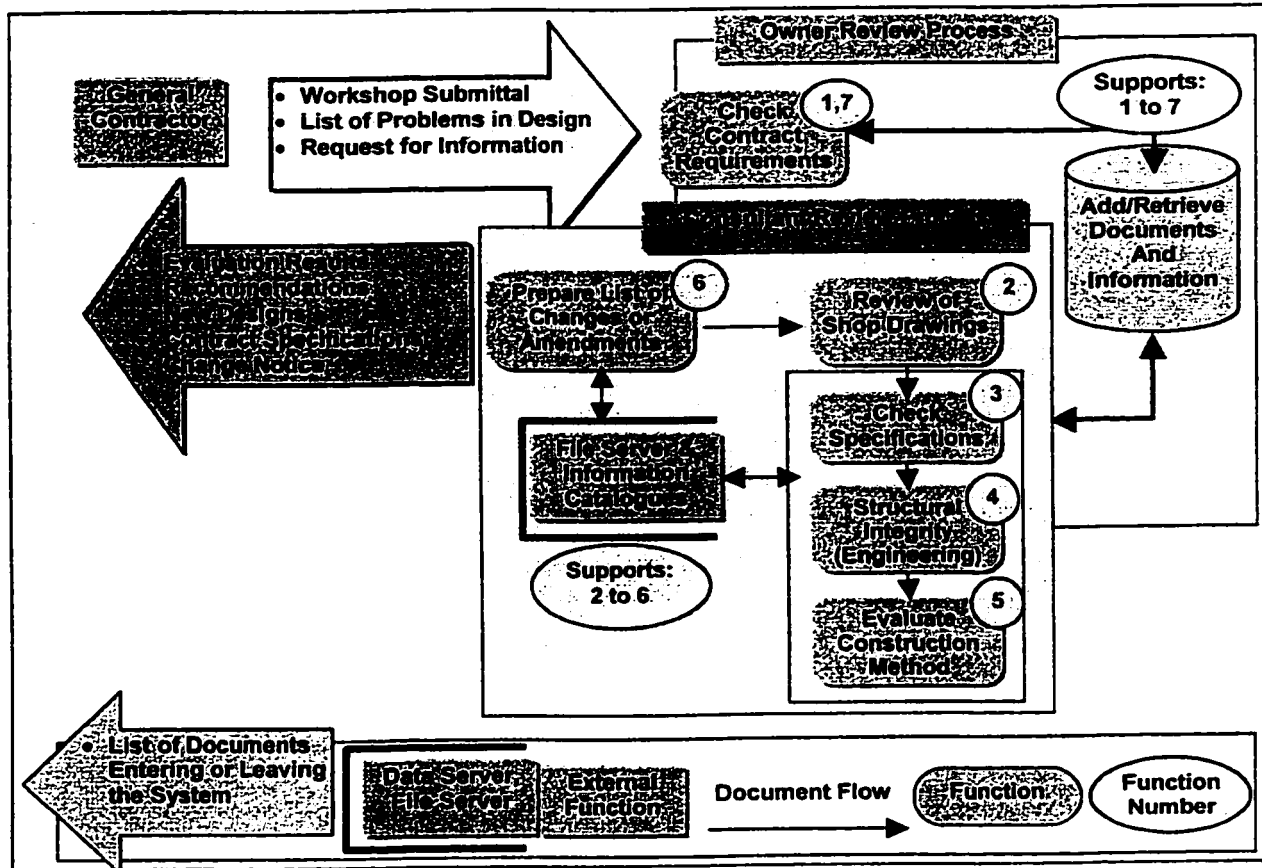

Figure-5.6: Detailed Document Flow Diagram (DFD) Shows The Sequence Of Functions For A Sample Engineering Design Change. .

DFD models provide static maps or snapshots, of varying detail, of possible or required or produced Meta data whenever a document is processed between project groups or functions. They postulate an idealization between any document-object or instance and the pertinent management function or process information [Hammad &

Alkass 2000-a]. Documents are associated with information about the Management Processes supporting actual construction work.

5.8 – Case-Based Document Categorization Examples

Case-based analysis, assists in visualising the UI and find the ways in which the user will interact with the system. That is in terms of data entry, querying of documents, and the shape of the reports or search results. The following examples cluster documents vis-à-vis possible claim categories, impact causes, or damage types.

5.8.1 – Labour Damage Document Profiling Example

Loss of efficiency means that higher numbers of man-hours are expended in order to carry out the same work. The causes of efficiency loss include:

- 1) More work than planned during a higher wage or labor shortage periods.
- 2) Overtime ordered by owner, which means premium wages.
- 3) Overtime because of constructive acceleration.
- 4) Overtime and weekend for expedient occupancy by owner.

Loss of productivity—a labor related damage—means using higher Man-hour costs to do the same type of work by the same trade or craft. Some causes are:

- 1) Stacking of trades in tight sites causing congestion and workflow problems.
- 2) Idle workforce waiting for instructions by consultant or owner.

- 3) Training new labor during work hours.
- 4) Not finalizing change orders and wasting work on non-critical functions.
- 5) Equipment breakdowns.
- 6) Disruption to normal work rhythm and losing momentum.
- 7) Poor labor and supervisory morale.

In Figure-5.7, a host of proposed Contemporaneous documents are clustered and related to productivity impact issues.

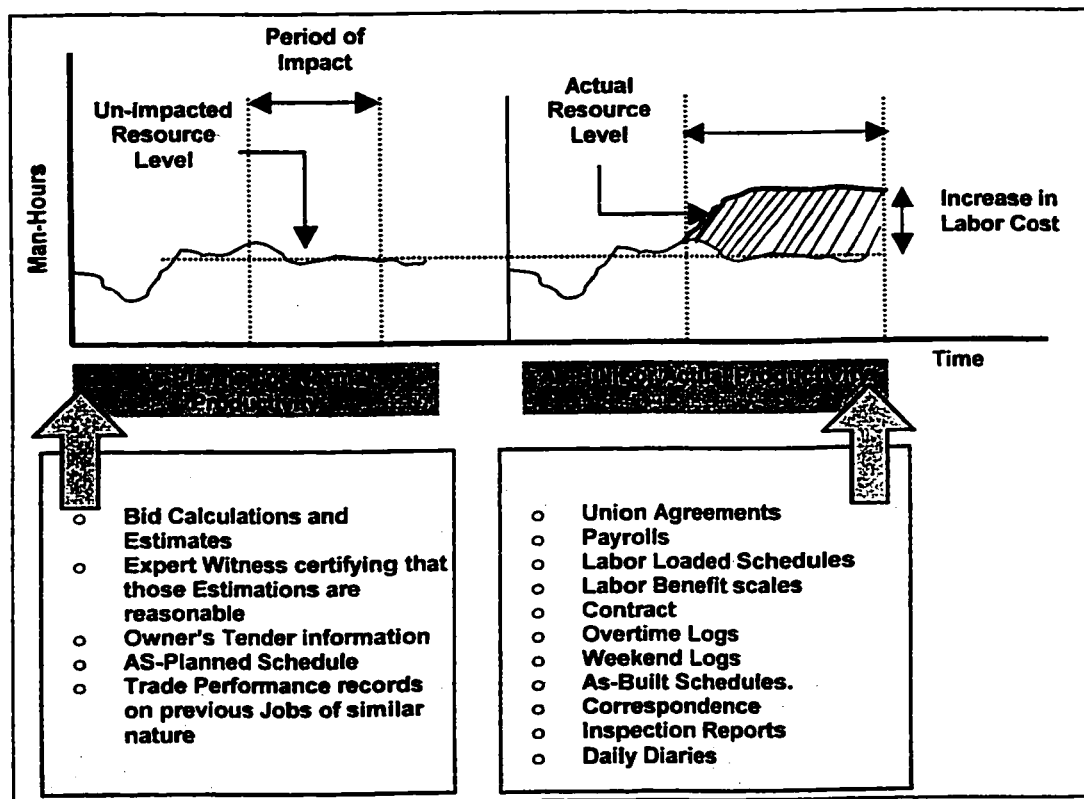

Figure-5.7: : Profiling Documents according to Damages [Hammad & Alkass 2001-a]

Hence, future design of the DMID shall allow the group managers to narrate, link, and profile any document with keywords and subject taxonomies according to damage

types, causes, and other information such as productivity or the likes of cost problems. Such classifications facilitate recalling relevant proofs.

5.8.2 – Delay Claim Document Profiling Example

It is important to isolate delays, determine their time spans, concurrency, and identify the responsibility. Extended performances (delays) need a variety of scheduling techniques, including computerized network diagramming (e.g. Primavera®, MS Project®) to adjust As-Built schedules with delays, or update baselines. Two main schedules are prepared for that, they are:

- 1) Reasonable “As-Planned” performance schedules.
- 2) As built” performance schedules, reflecting relevant delays.

A Sample delay case is demonstrated in Figure-5.8, and lists some of the documents that may be profiled and associated with delays for proving causes or impacts. A consensus as to the type and number of documents needed to prove a delay is not a problematic area. However, getting those documents from the various claim adversaries and learning about the whole picture is what is an obstacle. That’s because every group holds pieces of the project history and documentary puzzles. As-Built schedules can also demonstrate anticipated completion of the project, and absent architect or contractor delays. This shows how delays resulted from changes to the plan of construction by adjusting both activity durations and sequences.

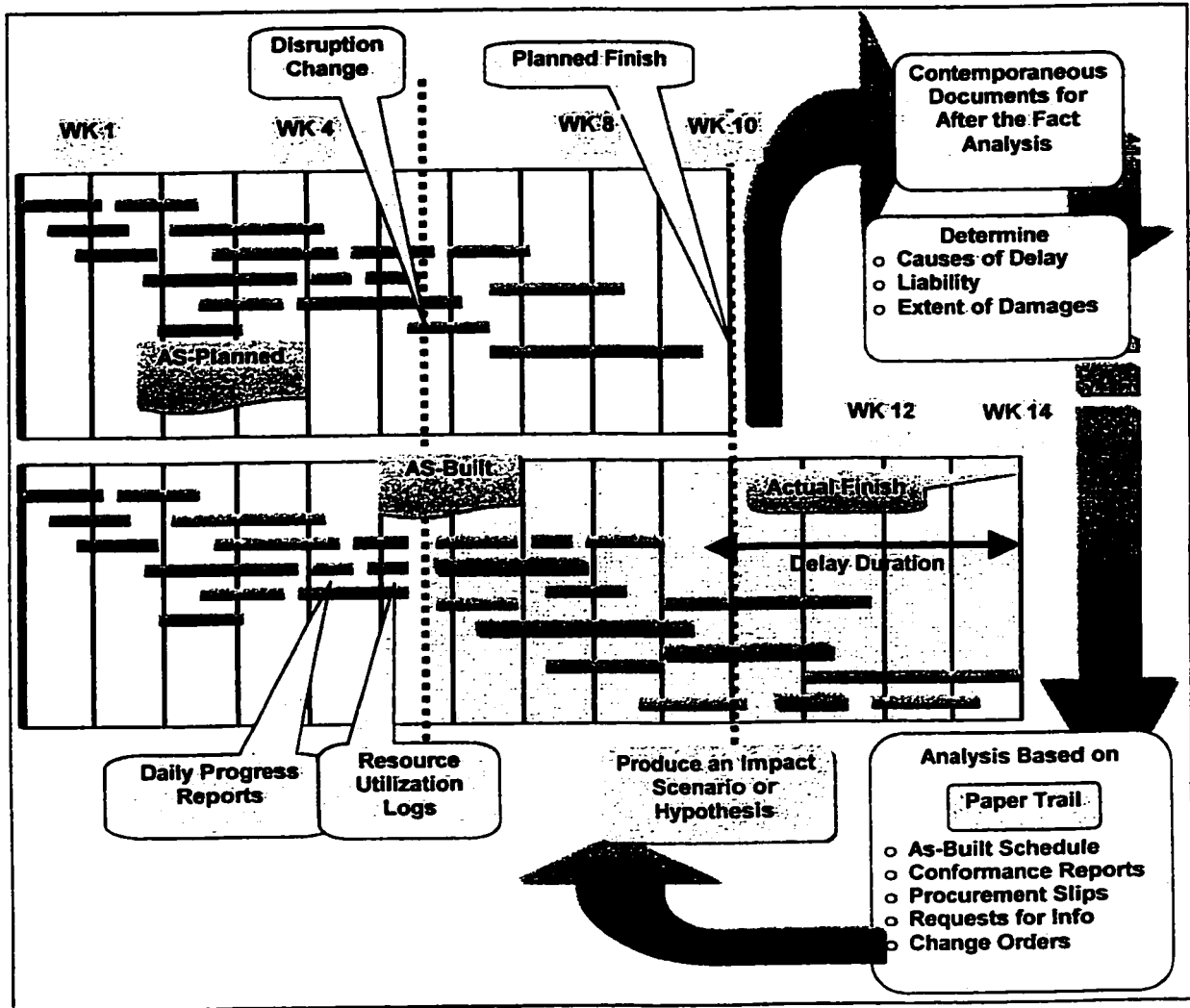

Figure-5.8: Paper Trail involved in the Analysis of Delay Causes and Impacts.

5.8.3 – Changes, and Extra Work Document Profiling Example

Change presents new requirements that constitute a departure from the contract's intent and agreements. A change would affect quantities, methods, activities' sequence, and work scope. Extra work needed to implement change is decided on a Direct Cost adjusted on a Quantum-Meruit basis, or a Cost Plus Incentive or Percentage. Unit costs for extra work are defined early on in the process within contract conditions. Also

negotiations can settle the dispute and remuneration using Lump Sum adjustments. Change is always in the mind of contracting parties, and therefore, is seen as a normal state of affair in this line of business. What is not normal, however, is when the cumulative effects of changes redefine the nature and scope of the project. Hence, proving changes vis-à-vis baselines and agreement milestones needs:

- 1) Considering departures from original product requirements.
- 2) Original performance conditions, and new conditions imposed by the changes.
- 3) Identifying changes in employed methods.
- 4) Identifying changes to the sequence of an operation.
- 5) Clear payment provisions and the method of payment for changes.
- 6) Settling specification changes, Equal-Clauses, and Proprietary specifications.
- 7) Calculating the time needed to carry the changes and to recover from impact.

5.9 – Classification of Claims Information

Classification helps in designing the UI for the CPDICenter website and information architecture based on claims types, issues, subjects, causes, types of impact, and damages. Also serves in the DMID design. There are certain data bits and contextual information that must be collected by construction groups during operations or when publishing (issuing) a document. This contextual information can relate to the Who, What, Where, When, and Why? Part of the construction event. The “Who?” part involves information about who sent, signed, witnessed, received, caused, stopped, started, built, met, tested, authorized, promised, said, released, paid, rejected, approved, supplied, supervised, designed, changed, added, removed...etc. The “Where?” part

involves information about the area, site location, weather, project systems, sources, delivery destinations...etc. The “When?” part, perhaps most critical, is concerned with the time events or activities took place, a delay or impact happened, also when a RFI was replied to...etc. The “How?” part is related to how the work was delivered differently from what was planned. Logistics, resources, methods, and procedures are but some of the things that are influenced by change or vice versa. DMID System end user is someone looking up documents for claims support, and needs both detailed and integrated views of documents. Integrated views could be claim reports with pre-determined folders, and files, list of affected construction components, claim subjects, and cost records.

5.9.1 – Claim Categories

Claims can be categorized in various fashions. For example according to project group that caused them, or according to type of impact a contractor suffered from, or the causes of claims. Nevertheless, There are six main categories:

Constructive Changes:

Such constructive changes have been recognized in the courts and usually take place as a result of the owner’s actions or inactions and cause more work or more time than planned to finish the job. In the contractor’s effort to provide a timely, and high quality product or service, he proceeds with the changes without strict compliance with

the contractual requirements. In such cases the owner refuses to execute formal change orders, which creates a dispute.

Acceleration:

Happens when the owner or his representatives order (explicitly) work to be completed sooner than required by the contract, or to finish within the original contract duration when delay extensions are due and excusable from the contractor's stand point. This type is commonly referred to as Directed Acceleration or an order to complete prior to contract completion date. Else, Constructive Acceleration indicates the owner's insistence on the original schedule when the contractor is entitled to an extension.

Changed Conditions:

Not expected or not possibly foreseen given the situation at site and the studies made on the project. There are two main types: 1) Unforeseen physical conditions differing substantially from those designated in the contract, and 2) Unknown physical conditions at the site, of an extraordinary nature, differing materially from those ordinarily encountered in works of similar character.

Schedule Change:

Pertains to changes to activity times, or their logical sequence in order to finish the works. May be caused by a suspension (work stoppage) for the owner or contractor's

advantage. Also may be due to a termination of a contractor for its bad work or malfunction. If termination is effected for the owner's convenience, profits on works completed and costs of demobilization are usually paid back to the contractor.

Delays:

From a contractor's perspective, there are three main types: a) EC excusable & compensable since they are caused by the owner, his designer, or his representative, b) EN excusable but not compensable because of the inescapable effect of a force majeure, and c) NE not excusable due to the contractor's own faults.

Other Types of Claims:

These include breach of contract, concealment of information, structural failures improper termination, and non-satisfactory performance by a contractor resulting in termination. The Material Breach represents a violation of an important contract obligation by the contractor. The Owner in certain cases may refuse to accept completed work and the contractor is forced to maintain and protect the work, which entitles the contractor for compensation. The owner in other occasions may wish to occupy the facilities and interferes with the Contractor, in which case the contractor is also entitled to interference impacts. Claims are also possible for Change in Scope or altering the purpose of the contract. Those scope changes could result in Cardinal Changes especially when the owner alters a project radically.

5.9.2 – Types of Damages

Whether plaintiff or defendant, construction groups have to be familiar with the different systems of cost accounting used in the construction industry to successfully refute opposing party's damages or assert claims for damages experienced. Consistent cost control records permit a project engineer or a claims analyst to study the impacts, estimate the damages and to present a claims report. Some damage categories are listed in Table-5.3.

Table-5.3: Damage Categories Used in Profiling Project Documents

1) Lost profits	11) Extended main office overhead
2) Weather inefficiency	12) Extended direct job expenses
3) Delay	13) Out of sequence work
4) Abandonment	14) Unresolved change orders
5) Defective performance	15) Liquidated Damages
6) Acceleration	16) Defective plans and specifications
7) Labor escalation	17) Termination
8) Material increases	18) Differing Site Conditions
9) Material storage/handling	19) Inefficiencies
10) Lost Investment Capital	20) Engineering and supervision

The DMID design benefits from an analysis developed in this thesis and cross-references documents with claims causes, global factors influencing projects, claim types, and delay types. This detailed analysis is presented partially in Table-5.4. Global factors cluster some causes according to project nature, owner sophistication, equipment and material procurement, labor industrial relations, design team experience, contractor's

familiarity with the type of works, and other supporting factors. The Claim Causes presented are not exhaustive, but sufficient to illustrate the concept being implemented in this thesis. Ticker marks (✓) are suggestive (author's point of view) of possible matches between the causes of impact, and a) global factors, b) delay types, and c) possible claim types that can be pursued in such situations. Such categorization of claims and impacts is also coupled with a host of different project subject keywords (taxonomy) that further classifies documents.

5.10 – DMID Conceptual and Design Schemas

The DMID centralizes the design around Document object instances. Claims information is structured and modeled in parallel to the modeling of the project facts, and processes. All information and data structures (models) are integrated to ultimately form the DMID.

This separation between the different information structures (e.g. documents workflow, contract requirements for claim documentation, Project process information, and claims information) is intended for mastering complexity, and to control future modifications and additions to the logical or physical DMID designs [Hammad & Alkass 2001-b]. Documents must be mapped to the project processes, production or management events. A document could be part of a trail of documents, which traces project progress, or just captures the state of an issue (e.g. delay claim) at hand at some given point in time. A document is viewed here as a time capsule that preserves a project's condition of interest, at a given instance, so as any one in the future will know what took place as if they were present (e.g. claim analysts who work A-Posteriori). In this respect, a document is an object instance, snapping a shot of what happened, or yet to take place. A document must have a unique identifier, distinguishable from other objects. also it is subject to rules and protocols, and can remember its affiliates (other documents), and offspring (versions, or revisions). Storing information inside a database protects it from accidental deletion, overwriting, or corruption. In addition, replication user access control, and automatic recovery procedures are additional benefits.

5.10.1 – DMID Relational Database Schema

The CPDICenters' database collects Meta information about each document in a consistent manner every time a new document record is inserted/added via the CPDICenter's website. The registration process (web-form: Chapter (Six)) solicits specific information from the group member when trying to add the new document record. Also there is information appended automatically to the database. For example, by virtue of adding a document to a specific directory in a specific group's Webfolder, that information is automatically added to the document record. The document information model, in Figure-5.9, integrates information about three components to enable easy updates of data and content without affecting the complex relations that exist in the relational database, or impacting project persistent information. Persistent information is established almost with the project conception. Examples of this type of information includes: sites, document titles, cost accounts, activities, resources, groups, members, contract clauses, specifications, and conditions. The three main project information components are:

- 1) The Project process control information.
- 2) Contract requirements and Workpackages.
- 3) Document Versioning, Workflow and Virtual Webfolders.

The Logical database design communicates to developers how the Relational data models should be mapped into the DBMS [Batini et. al. 1992]. The ER conceptual schemas are more persistent than logical or design implementations, because they depict

the interrelations between the objects of the project. Each table represents a subject, and subjects are related to each others using linking tables. Details of the EER (Extended ER schemas) depicting the conceptual DMID model are offered in Figure-5.10, and the design (Implementation) model is offered in Figure-5.11.

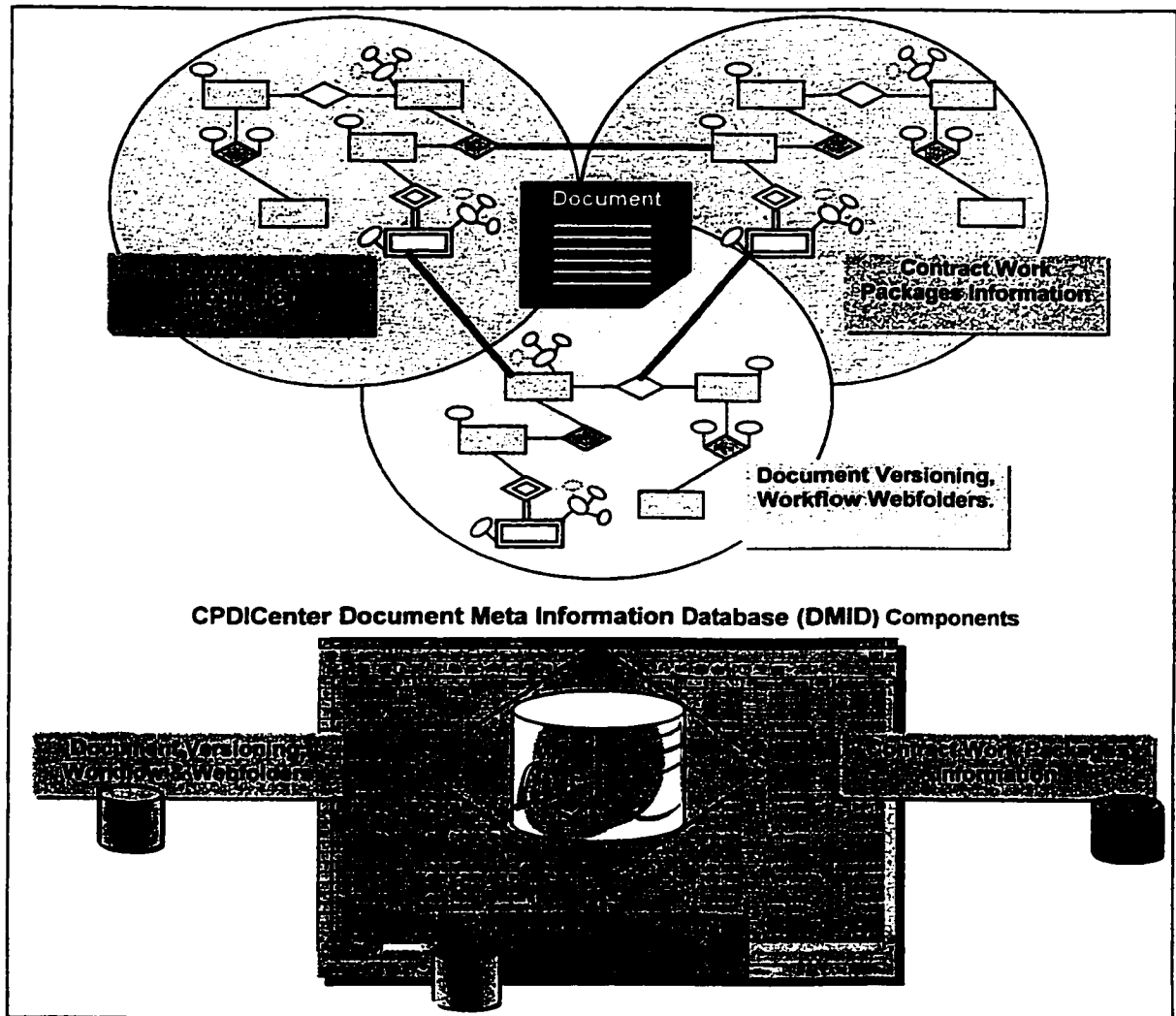

Figure-5.9: Main Information Components in the DMID

5.10.2 – Project Process Control Information Components

Construction work follows a hierarchical structure, made of sub-components that together make the whole. It is possible to Breakdown construction work into operations, processes, and tasks. Progress aggregates as finished components, or systems, or functions. The DMID uses the following information subjects to capture process control information: details of pproject activities, resources, cost accounts, project groups, sites, events, weather, and WBS—see Figures-5.10 and 5.11. Each document is at least linked with a project component and a cost account. This information should be consistent across all project groups

5.10.3 – Contract Requirements and Workpackages

Every document is related to at least one workpackage (cost center). The project groups with contract agreements initiate each workpackages. Such agreements eventually will contain conditions to guide the performance; also it will enclose product specifications, and quality requirements. Conditions of contract also serve to guide claims documentation and management in the eventuality of changes in conditions, scope of works, or the nature of the final product. The DMID models in Figures-5.10 and 5.11 benefit from the UML models illustrated earlier in Figures-5.4, and 5.5 in which contract requirements, process control, and workflow information are all linked with the document object.

5.10.4 – Document Versioning, Workflow and Virtual Webfolders

This part associates claims classification information (i.e. causes, global causes, damage types, type of changes, claim type, and delays), with other information subjects including: project groups, CPDICenters, document workflows, document files, and document class types. Topic keywords from the project are produced and used to classify anything from documents, to claim issues, or events. The reader can notice that the three information components do overlap with each other's—Figures-5.10 and 5.11. Hence, data integrity has to be maintained at three levels:

- 1) Table Structure
- 2) Field Specification
- 3) Table Relationships

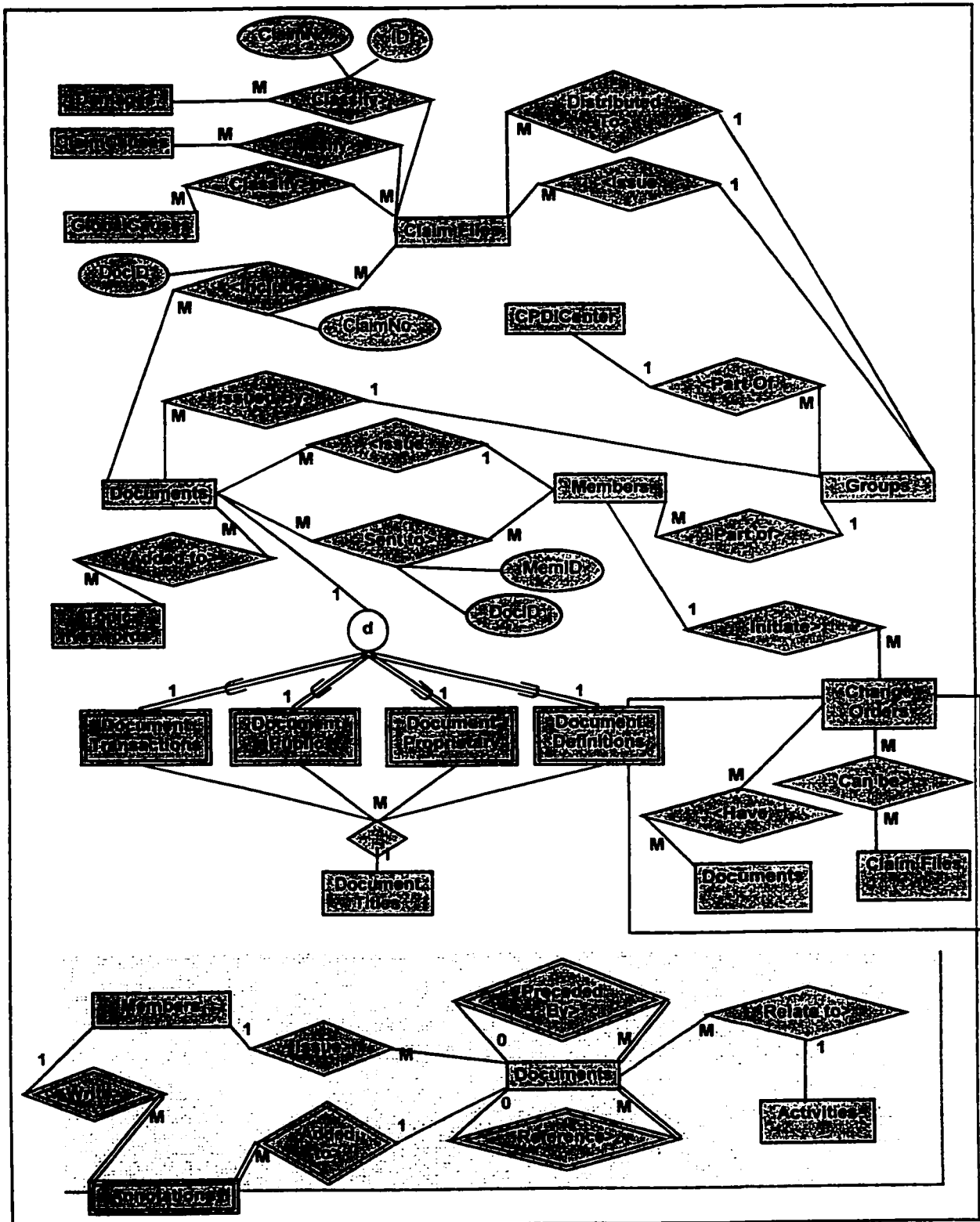

Figure-5.10: Conceptual EER Model Of the DMID

Every new version of a document represents a new document in the CPDIDCenter. A version number is issued to link the documents in a traceable trail—see Figure-5.12. Any claim analyst will be able to focus on the latest release of a document (last revision or version) or track it back to the original document to check out changes along the way. This is very useful since many plans, and schedules are released on stages and every new edition (version) carries some changes that project groups have to be aware of.

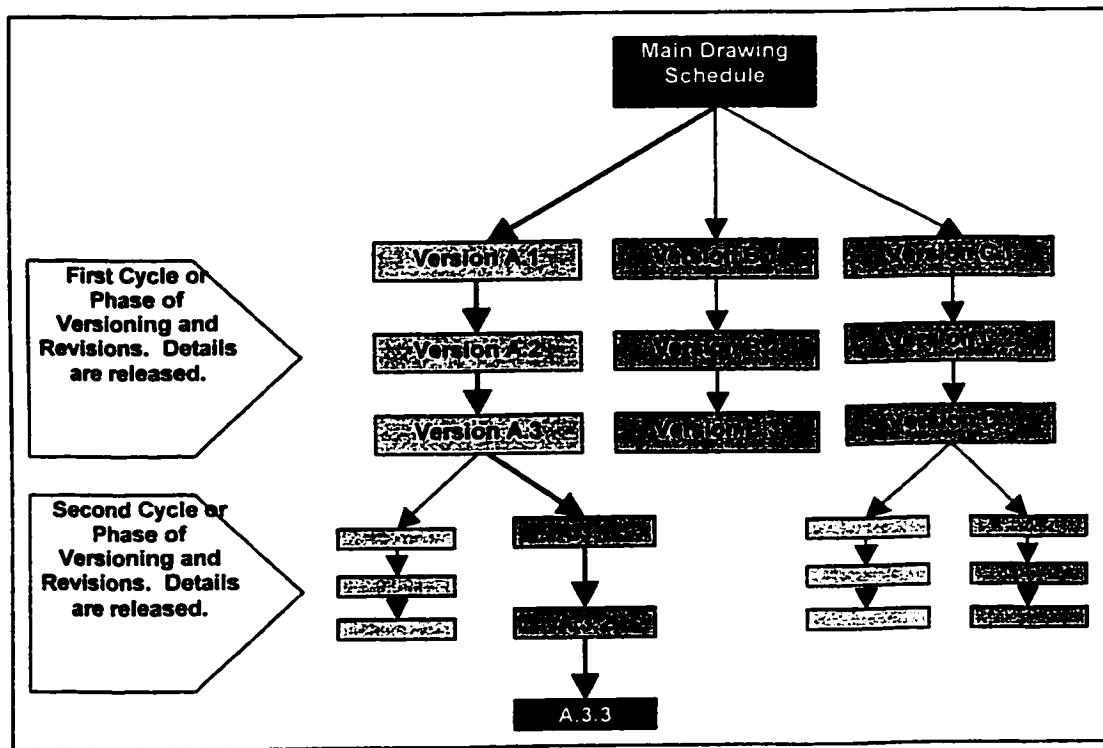

Figure-5.12: Version Tracking Schema inside the DMID

A revision is merely another release of the document with minor changes, like annotations or redlining a CAD drawing. If a document is re-released with any changes, minor or major, then it is a new document.

5.11 – CPDIDCenter DMID Validation and Hypothetical Case Project

As a proof of concept and to validate the integrity of the DMID table structure and table relations, the DMID conceptual model was mapped into an EER design schema in a RDBMS (MS Access 2000). This is to demonstrate the various essential functions of the DMID in supporting online queries via the virtual center. In Chapter 6 the DMID connection with the website is established, and all queries are tested using web forms. A sample project was experimented with to populate the DMID. It consisted of a highway project adapted from a sample-training project that ships with Primavera P3. The project has 51 activities, 35 cost accounts, and two sectors (North and South bounds). The project also has 32 resource categories.

For this project the CPDIDCenter deploys the four document classes: 1) Proprietary, 2) Definitions, 3) Public, and 4) Transactions developed in this thesis. Referring to Appendix A, the DMID shall use 95 document titles, and 45 document categories. It contains as well reference tables for project specifications, Masterformat divisions, sites, WBS, Workpackages, project groups, project group members, conditions, and contract agreement clauses. Claims tables include: claim damages (54 types), claim causes (66 causes), and claim files. There are separate tables for contract changes, and C.O.s tracking. Included also is a table to track events, and weather information. Some snapshots from the CPDIDCenter DMID implementation and project information are presented in Figures-5.13, to 5.18. The project information and document classification tables are implemented.

The DMID is accessed via the CPDIDCenter website (Chapter 6). The DMID is implemented with MS Access™ 2000 [Jennings 1997], in a Windows environment. Access to the DMID is via HTTP protocol using an IIS4.0 Information Server. The CPDIDCenter Document Files Table in Figure-5.18 is linked to the Four Document Class Tables. Every Document is listed in one or more of the Document Class Tables.

P1G098	BEGIN PROJECT		23/04/1999	23/04/1999
P1G100	MOBILIZATION	Independent	10/05/1999	23/04/1999
P1G105	CLEAR SITE	Meeting	30/04/1999	23/04/1999
P1G110	GENERAL CONDITIONS		10/06/1999	10/06/1999
P1G2008	PROCUREMENT OF ESW/SL SIGNS	Finish Milestone	19/11/1999	19/11/1999
P1G5200	CONSTRUCT CONCRETE BARRIER AGAINST WALL	Start Flag	23/07/2001	23/07/2001
P1N1140	PLACE TEMP. MARKING TAPE	Finish Flag	03/06/1999	03/06/1999
P1N1145	PLACE TEMP. CONST. BARRIER	Hammock	04/06/1999	04/06/1999
P1N1150	EXCAVATE	WBS	28/06/1999	28/06/1999
P1N1170	PLACE AGGREGATE & ASPHALT BASE COURSE	Task	14/07/1999	14/07/1999
P1N1180	REMOVE TEMP. CONST. BARRIER	Task	23/07/1999	23/07/1999
P1N1185	PLACE 2" SURFACE COURSE	Task	07/08/1999	07/08/1999
P1N1190	DIVERT TRAFFIC ONTO TEMP. ROAD	Task	20/08/1999	20/08/1999
P1N1195	REMOVE TEMP. MARKING TAPE	Task	01/09/1999	01/09/1999
P1N1200	PLACE CONST. BARRIER & TEMP. STRIPING RAMP	Task	17/09/1999	17/09/1999
P1N1202	CONSTRUCT TEMP. BENT #1 & #2	Task	17/07/1999	17/07/1999
P1N1210	EXCAVATE RAMP & INSTALL 15" RCP PIPE WITH INLETS	Task	18/10/1999	18/10/1999
P1N1220	PLACE AGGREGATE & ASPHALT BASE COURSE	Task	15/11/1999	15/11/1999
P1N1230	PLACE 2" SURFACE CO			
P1N1235	REMOVE TEMP. CONS			
P1N1240	PLACE TEMP. STRIPING			
P1N2100	PLACE CONST. BARRIE			
P1N2105B	INSTALL EROSION CON			
P1N2115A	GRUB & STRIP TOPSOI			
P1N2190	INSTALL SIGN SUPPOR			

ActivityID	Text	(PK) Activity Unique ID
ActivityDescription	Text	Description of the activity
ActivityType	Text	start, finish, task, independent, meeting, milestone
ES	Date/Time	Early Start Date
PlannedStart	Date/Time	Planned Start Date
OD	Number	Original Duration in Days
ActualStart	Date/Time	Actual Start Date
SiteID	Text	Site ID to identify a site location, can be a combination of text
WBSCode	Text	Each WBS can have many activities. This WBS is the Work Breakdown Structure
Critical	Yes/No	Critical is True or Yes
Milestone	Yes/No	Milestone is True or Yes
ChangeWork	Yes/No	Change work is True or Yes

Figure-5.13: Project Activities Table and Field Descriptions in the CPDIDCenter Master Database. The Project has 51 Activities

010100 G	General Field Conditions	General & Overhead	P1	Starting
015300 E	Construction Facilities & Temp. Controls	Equipment	P2	Traffic
015300 G	Construction Facilities & Temp. Controls	General & Overhead	P1	Starting
015300 L	Construction Facilities & Temp. Controls	Labor	P2	Traffic
015500 E	Access Roads	Equipment	P1	Traffic
015500 L	Access Roads	Labor	P1	Traffic
015900 E	Signs	Equipment	P1	Signage
015900 L	Signs	Labor	P1	Signage
021100 E	Site Clearing	Equipment	P1	Earth
021100 L	Site Clearing	Labor	P1	Starting
021200 E	Site Removals	Equipment	P2	Earth
021200 L	Site Removals	Labor	P2	Earth
021600 E	Underpinning	Equipment	P1	Earth
021600 L	Underpinning	Labor	P1	Earth
022250 E	Excavation & Backfill	Equipment	P1	Earth
022250 L	Excavation & Backfill	Labor	P1	Earth
022270 L	Erosion Control Earth Work	Labor	P1	Earth
022270 M				
025100 E				
025100 L				
025100 M				
025400 E				
025400 L				
025400 M				
027100 E	Subdrainage Systems	Equipment	P1	Earth

CostAcctTitle	Text	(PK) Cost Account Code: E: equipment, L: labor, M: Material, G: General
Cost Account Name	Text	Cost Account Name
CostType	Text	Cost type: Labor, Material, Equipment, General
SubProject	Text	Name of the sub project or sector
WorkType	Text	General Construction, traffic, electrical, civil, signage, closeout, earth, sta

Figure-5.14: Project Cost Accounts Table and Field Descriptions in the CPDICenter Master Database. The Project has 35 Cost Accounts

109	Requests for Clarification
11	BCWP
110	Resource Allocation
111	Reworks
112	Safety
113	Schedule for Recovery
114	Schedule Look Ahead
115	Schedule of Deliverables
116	Schedule Updates
117	Scope
118	Severe Weather
119	Shop Drawing Certificates
12	BCWS
120	Shortages
121	Shutdowns
122	Site
123	Site Cleaning
124	Site Conditions
125	Site Congestion
126	Site Inspections
127	Site Meetings
128	Site Overhead
129	Site Planning
13	Bid Documents

1	As-Built Drawing
2	As-done Schedule
3	As-Planned Schedule edition
4	PCWBS
5	CBS Diagram
6	RBS Diagram
7	WBS Diagram
8	BOQ, Bill of Quantities
9	Change interpretation notice
10	Change order
11	Close-out Check List
12	Work Order
13	Drawings
14	Drawings
15	Drawings
16	Earnings
17	Employment
18	Excavation
19	Extensions
20	Fields
21	Fields
22	Forms
23	Incidents
24	Interactions
25	Inventories

DefnCategory	Anal	10
6	Contract Special Specs	As-Built Drawing
41	Contract Specifications	As-Planned Schedule edit
55	O & M manuals	As-done Schedule
121	O & M manuals	WBS Diagram
0		
	Control WBS	
	Control Cost Accounts	
	Control Resource	
	Control WP	
	Communication Procedure	
	Project Groups	

Figure-5.15: CPDICenter's Document Categories, Keywords, and Document Definitions Class Tables.

24	Bad Quality Reworks	Dmg-ABDN-01	Abandonment
31	Cardinal Changes	Dmg-ACCL-01	Acceleration Overtime
42	Change of work Sequence by Owner	Dmg-ACCL-02	Acceleration Trade overcrowding
45	Change Orders	Dmg-CHGO-01	Change Orders Unresolved
68	Change Orders	Dmg-CSLT-01	Consulting Experts
2	Changes in Method	Dmg-DELY-01	Delays
46	Code Changes	Dmg-DFCT-01	Defective Material
51	Consequential Changes by Owner	Dmg-DFCT-02	Defective Performance
9	Constructive Acceleration	Dmg-DFCT-03	Defective Specifications
39	Contract Discrepancy	Dmg-ENGR-01	Engineering
27	Contractor Breach	Dmg-ENGR-02	Forensic Services
54	Cumulative Effect of Changes	Dmg-EQPT-01	Equipment Rental
4	Defective Drawings	Dmg-EQPT-02	Equipment Failure
35	Defective Specifications	Dmg-EQPT-03	Equipment Increased Wear & Tear
22	Design Error	Dmg-EQPT-04	Equipment Special needs
8	Directed Acceleration	Dmg-EXTD-01	Extended Direct Job Expenses
43	Disallowing Valid Delays	Dmg-EXTD-02	Extended Head Office Overhead
29	Early Facility Occupancy	Dmg-EXTD-03	Extended Site Overhead
34	Faulty Owner Suppl'd Material	Dmg-FINC-01	Finance Cost for Extended work
33	Force Majeure	Dmg-FINC-02	Finance Insurance for Extended or delayed
11	Hidden/Unusual Conditions	Dmg-FINC-03	Finance Lost Investment Capital
5	Higher Quality Standards	Dmg-FINC-04	Finance Lost Profits
49	Impossibility of Performance	Dmg-FINC-05	Finance Material Cost Increases
62	Impossible Method	Dmg-LABR-01	Labor Escalation
61	Impractical Design	Dmg-LABR-02	Labor Holiday Premium Cost
		Dmg-LQDT-01	Liquidated Damages
		Dmg-LQDT-02	Liquidated Owner Late Occupancy
		Dmg-OVTM-01	Overtime Equipment Cost

Figure-5.16: CPDICenter Claim Causes, and Claim Damages Tables

100.00	GENERAL REQUIREMENTS	Or Equal	01NB
101.00	TERMS, FORMAT, AND DEFINITIONS	Special	02NB
101.01	Meaning of Terms	Custom	
101.02	Specifications Format	Or Equal	01NB
101.03	Abbreviations	Or Equal	
101.04	Definitions	Or Equal	
102.00	BID, AWARD, AND EXECUTION OF CONTRACT	Or Equal	
102.01	Acquisition Regulations		
102.02	Preparation of Bids	Or Equal	
102.03	Bid Guarantee	Special	
102.04	Individual Surety	B	
102.05	Public Opening of Bids	Proprietary	
102.06	Performance and Payment Bonds		
103.00	SCOPE OF WORK		02NB
103.01	Intent of Contract		
103.02	Disputes		
103.03	Value Engineering		
103.04	Contractor Records		
103.05	Partnering		
104.00	CONTROL OF WORK		
104.01	Authority of the Contracting Officer		
104.02	Authority of Government Inspectors		
104.03	Specifications and Drawings		
104.04	Coordination of Contract Documents		
104.05	Load Restrictions		

Figure-5.17: CPDICenter Contract Specifications Table

3	30/10/1998	abc345	P1G105	GCons1.5	Issuer & Receptants	1	1
6	01/01/1991	ab322	P1G200E	GCons3.1	Only within CPDIDCenter Level	1.1	2
22	01/01/1991	abk324	P1G110	GContr1.4	Only Groups in Contract		
41	07/05/2001		P1G100	Holding1.3	Only within CPDIDCenter Level		
54	01/01/1991		P1G110	GContr2.1	Only Issuer		
55	01/01/1991		P1G105	Holding1.3	Issuer & Receptants		
121	01/01/1991		P1G520C	GContr1.4			
0				SubCons3.	All		
0					Project Public		
					Only Issuer		
					Issuer & Receptants		
					Temporary View		
					Only within CPDIDCenter Level		
					Only Groups in Contract		

1	Work item 23A is scheduled for next week	ALISAH	<input type="checkbox"/>	<input checked="" type="checkbox"/>
2	Standards for Installation of Signals	ANNHEI	<input checked="" type="checkbox"/>	<input type="checkbox"/>
	Safety Meeting	WENMAC	<input type="checkbox"/>	<input type="checkbox"/>
	Group must specify method	ANDFUL	<input type="checkbox"/>	<input type="checkbox"/>
	Trials are underway to test Pavement	OMARAB	<input type="checkbox"/>	<input type="checkbox"/>
	Temporary Generators are Installed	CHAGOU	<input type="checkbox"/>	<input type="checkbox"/>
	Traffic Signals tested and Approved		<input type="checkbox"/>	<input type="checkbox"/>
		CHACOO	<input type="checkbox"/>	<input type="checkbox"/>
		CHAGOU	<input type="checkbox"/>	<input type="checkbox"/>
		CHESAY		
		DIRLUC		
		ELINOZ		
		EUROS		
		GIOGIU		

Figure-5.18: CPDIDCenter Document Files Table.

5.12 – Standardizing the DMID development

The DMID development effort can be standardized, as charted in Figure-5.19, which is an idealization of a systems approach to consistently reproduce the same DMID conceptual and design models. It also establishes the DMID as a manageable function. Changes to the DMID models, even when intended for the construction project, are still valid for any project setting with minor changes to the business rules pertaining to EER table relations' specifications, and table fields' specifications. The integrity of the EER design model remains viable, because the principles invested in its design are in concordance with project management normative.

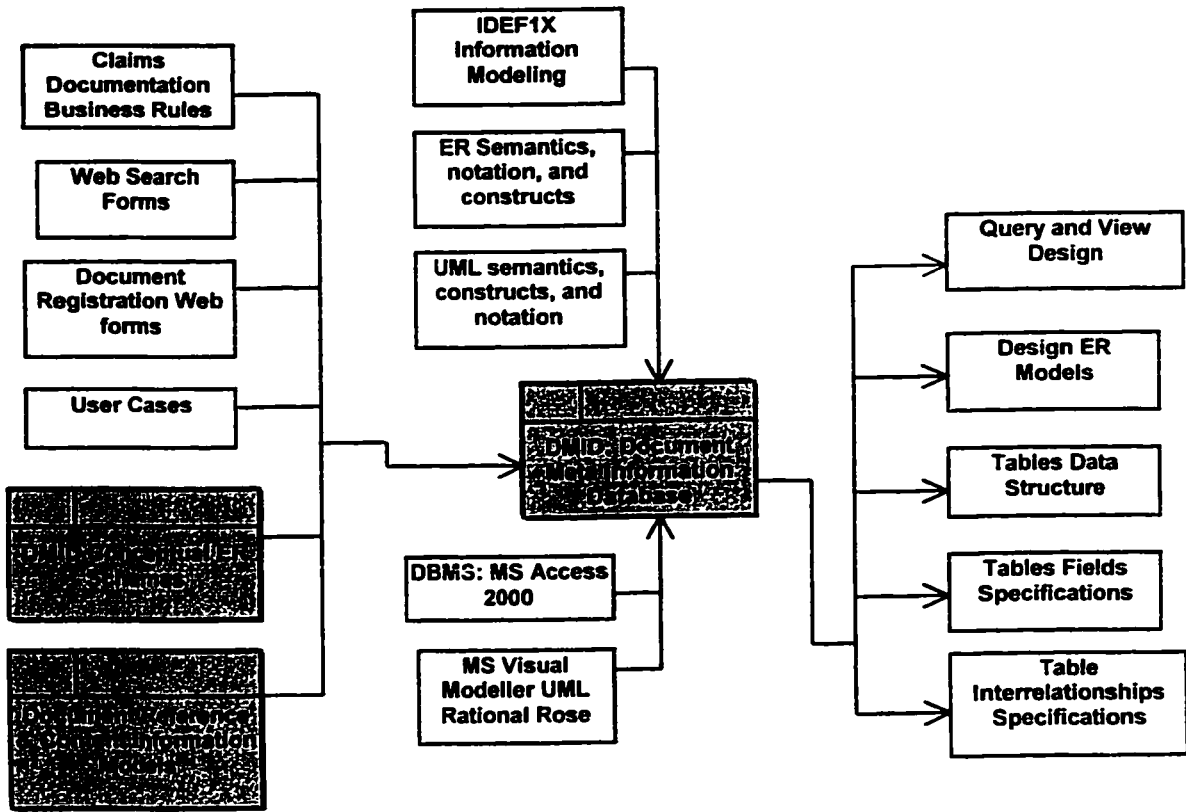

Figure-5.19: Standardizing DMID development with an IDEF0 Systems Approach



Chapter Six *Implementation and Validation of The CPDIDCenter Services*

The CPDIDCenter Website is a Portal for access to documents generated and stored by the project enterprise. The CPDIDCenter information infrastructure was developed earlier in this thesis, and it may work alone or, with proper technology it can sustain other knowledge management applications such as data mining. The CPDIDCenter website structure relies on the information classification, indexing and organization of documents into a structure pertinent to claims, as well as other project issues [Hammad 2000-c].

6.1 – *CPDIDCenter Management*

Managing the services of the CPDIDCenter can be carried out centrally or delegated to individual project groups within a set of rules and procedures. Management involves several important functions:

1. Updating DMID, monitoring table structure and table fields
2. Monitoring access and use
3. Updating contents for webfolders and website pages
4. Maintaining servers

6.1.1 – Central VS distributed management

Project organizations evolve with construction phases, and that may dictate the need for an independent Project Information officer (PIO) to run the CPDICenter. Some issues that need groups' agreement are: cost distribution, server locations, and access rights. Distributed management, on the other hand, is an option, but groups have to maintain their webfolders, and portions of the DMID replica, within a set of agreed upon rules and procedures. Project groups should offer access to their resources and host some services of the CPDICenter. A client/server environment can be created, as well, where each group can be a client (looking for information) and a server (providing information) without the need for a central database or server. This is tagged as a Peer-To-Peer (P2P) communication. The website can be hosted by any project group, with the website pages working only as pointers to document repositories, and information sources. Figure-6.1 illustrates this type of management, and a comparison between both approaches is in Table-6.1.

Table-6.1: Central vs. Decentralized CPDICenter Management

Component	Centralized Management	Decentralized Management
DMID	Master database in each Center, and synchronized with other Centers'	Segmented databases (partially replicated). Maintained by several groups
Webfolders	Master webfolders reside in the data tier in each Center; local replicates at groups' client side	No master webfolders, rather each group hosts its master (or local) webfolder, and serves it to whoever seeks information via the Center Website.
Servers	In the Centers, except for gateway or access servers are at client side	Can be at any group's server or part of its intranet, or network.
Workflow	Central Processing	Each group maintains its workflow system
Website	A Project Information Office (PIO) anywhere in the enterprise can host it. A collection of Centers make up an Enterprise CPDICenter.	Hosted by one major construction group in the project, the group has to last till the end of the project. The CPDICente is the property of the project.

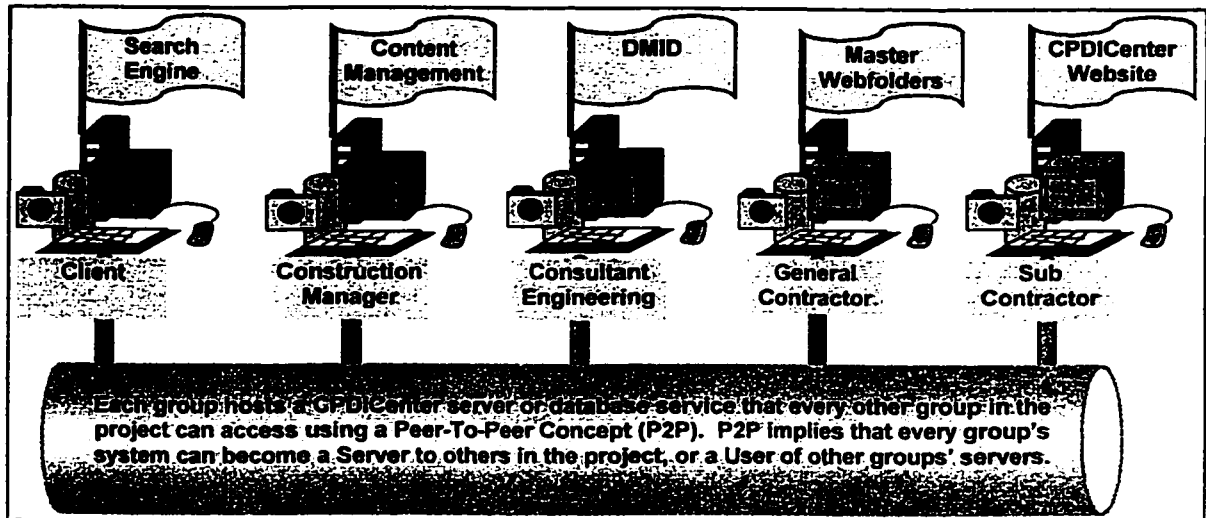

Figure-6.1: CPDIDCenter Peer-To-Peer (P2P) Distributed Management Architecture.

The CPDIDCenter is promoted here as a central solution for documents' storage and information control. That's because some groups will not persist throughout the life of the project or might join during work operations and leave or before de-commissioning of facilities to owner. Moreover, not all groups are capable—technically—to support the CPDIDCenter services, and it will be much harder to make all groups conform to standardized document storage and workflow procedures with a decentralized management.

6.2 – CPDIDCenter Access and Document Flow Amongst Groups

CPDIDCenters are virtual project portals, which are hosted by one or more web servers at one or more locations. For a traditional project organization Figure-6.2 shows how CPDIDCenters are translated into equivalent portals. Project groups/participants (contractors, subs, consultants, client...etc.) are invited by a Project Information Officer (PIO) to register their portals within their CPDIDCenters and add group members. Groups

can share in more than one Center, and have to get a distinct URL or portal address for each one. This entails also a separate master Webfolder for each Center they are part of.

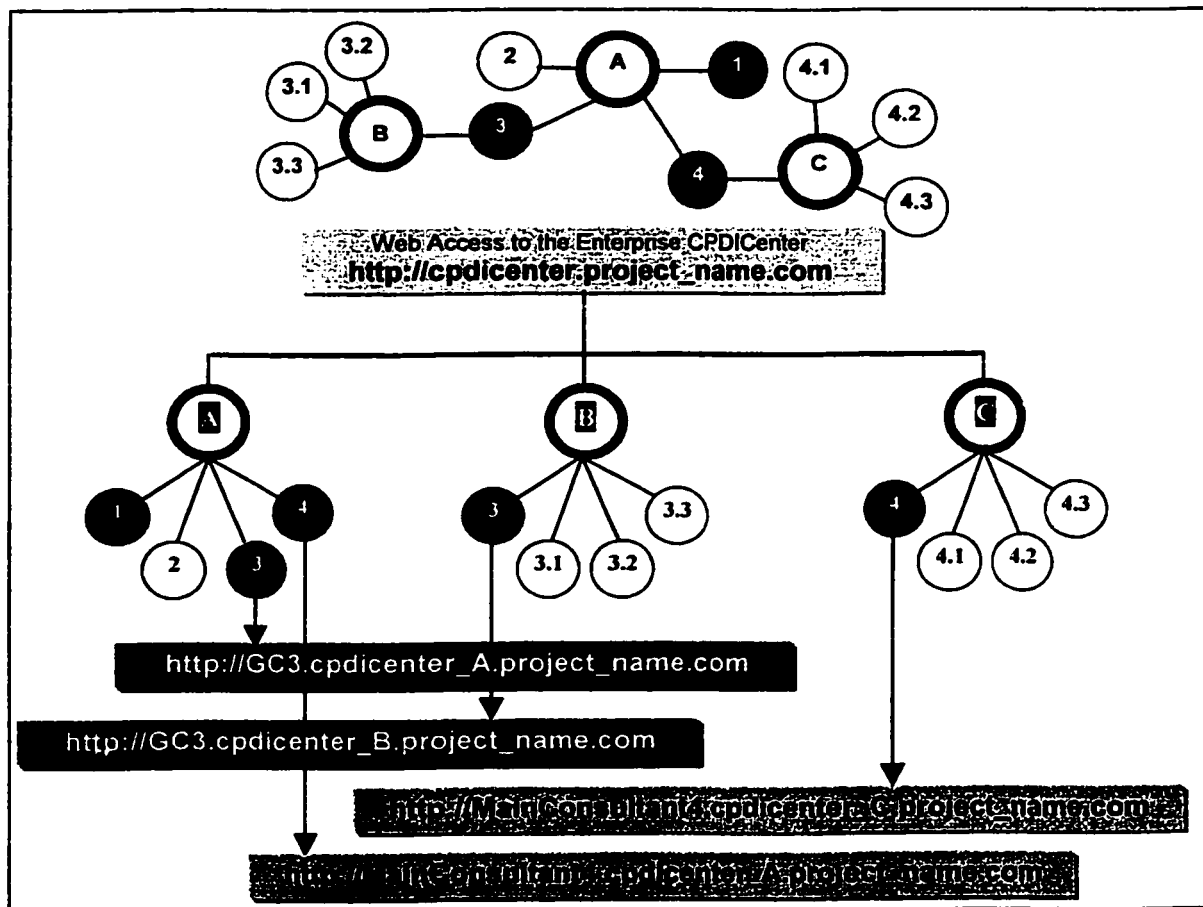

Figure-6.2: Web Access to Project Groups' CPDICenters

For example, in Figure-6.2, we find the General Contractor (No.3) is part of Center A with a URL: [http://GC3.cpdicenter_A.project_name.com], and part of Center B with a URL: [http://GC3.cpdicenter_B.project_name.com]. Therefore, documents that are generated by and/or exchanged with groups in Center A are hosted at that Center's DMID and Webfolders.

6.2.1 – Mapping the Flow for Claim Documentation

For the common case of latent physical soil conditions, contractors have to decide if the conditions are unanticipated and unforeseen. Assuming a traditional project delivery, shown in Figures-6.3 and 6.4 adapted to the CPDIDCenter concept, the project groups will exchange this knowledge of site facts among each other's.

The case is escalated to the client's consultant and a RFI (Request for Information) is issued about the unveiling conditions—see Figure-6.3. This case produces a paper trail of proposals and counter proposals with every documentary flow designated by a DF symbol and a sequence number to distinguish it from others preceding or succeeding it. For instance, DF4 is a document relayed by the main consultant to his sub-consultant to study the case.

Those DFs are all mapped in a sequence diagram in Figure-6.4, which details, on a higher level, document workflows and how documents traverse CPDIDCenter groups.

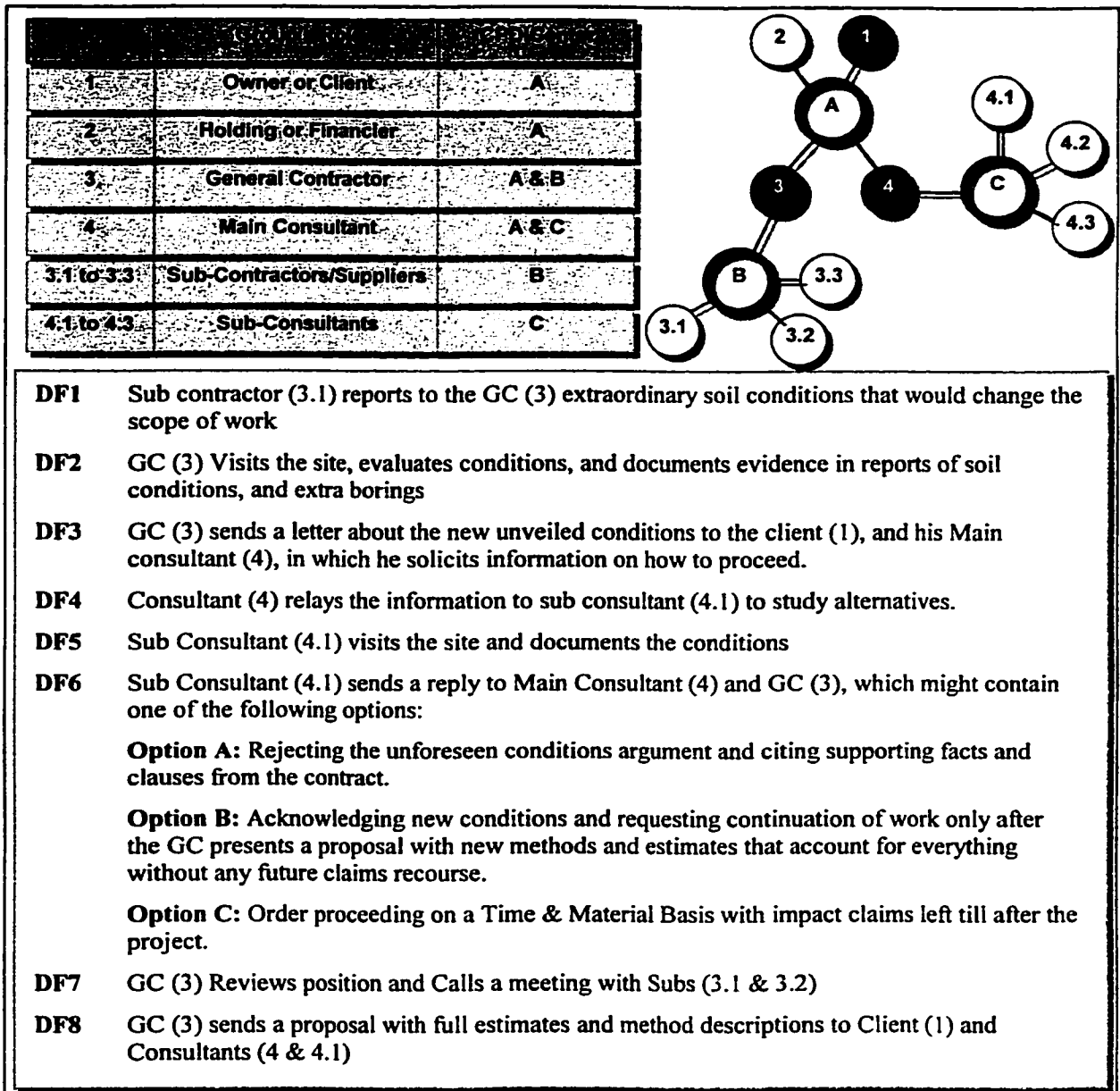

Figure-6.3: Example of a Detailed document Workflow among groups in the CPDICenter Enterprise

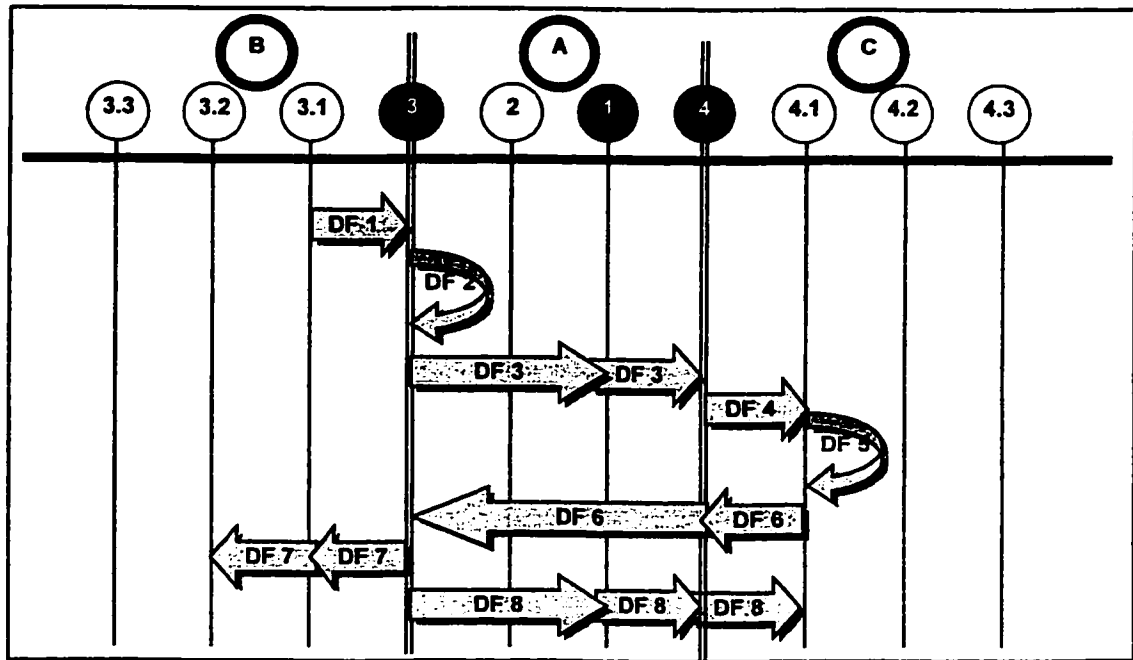

Figure-6.4: Detailed Sequence Diagram Mapping Document Workflows among Enterprise CPDIDCenter Project Groups.

6.3 – Software Tools and Technology Used in Development

Web technology is still evolving as long as standards are being established for the software and hardware industries to follow. In terms of technology, the CPDIDCenter prototype website and database developments were carried out with a Pentium class computer (166MHz mmx), 64Mb Ram, 4MB Graphics Accelerator, and a 33.6Kbp Internal Faxmodem. Software utilized, mainly Microsoft tools like MS Access™ 2000 for the implementation of the database design; MS Visual Interdev™ 6.0 for web project development, connection with the DMID, site management, and testing; MS FrontPage™ 2000 and MS Word™ 2000 for design of WebPages' contents, layouts, forms, and UI simulation. MS Information Server™ 4.0 (IIS 4.0) and MS Personal Web Server™ (PWS) are deployed as virtual web servers at the host computer to facilitate prototyping

and validation of the feel and behavior of the website-database systems in response to real user interaction situations.

Website programming languages included: HTML 4.01 (HyperText Markup Language)—the publishing language of the World Wide—based on the W3C (World Wide Web Consortium) specifications. HTML 4.01, supports multimedia options, scripting languages, and style sheets. HTML is an SGML (Standard Generalized Markup Language) application conforming to International Standard ISO 8879. Web-database interactions or data querying, and user form validation and access rights were programmed with ASP® 3.0 (Active Server Pages), and MS VB™ Script for both the client and server side instructions. Webpage styles and themes are set with CSS 1.1 (Cascading Style Sheets), part of the W3C recommendations. Visual Basic Scripting, a subset of the Visual Basic® programming language, is a portable, lightweight interpreter for use in World Wide Web browsers and other applications that use Microsoft® ActiveX® Controls, Automation servers, and Java applets. JScript® 5.0, is an interpreted, object-based scripting language that targets the Internet.

Although it has fewer capabilities than full-fledged object-oriented languages like C++ and Java, JScript is more than sufficiently powerful for its intended purposes. JScript scripts can run only in the presence of an interpreter, either in a Web server or a Web browser. Jscript, used here for UI animations, Form validation, and client-side run applications, is loosely typed, a single variable can hold different types of data over the course of a script. A description of how the aforementioned technologies are integrated

and incorporated in the CPDICEnte development, and search querying are explained in Figure-6.5. DMID querying utilizes SQL(Standard Query Language)–used within HTML, ASP, and Java scripts–for looking up document information and creating views. In the next sections, sample shots from the search, retrieval, and document registration pages are presented.

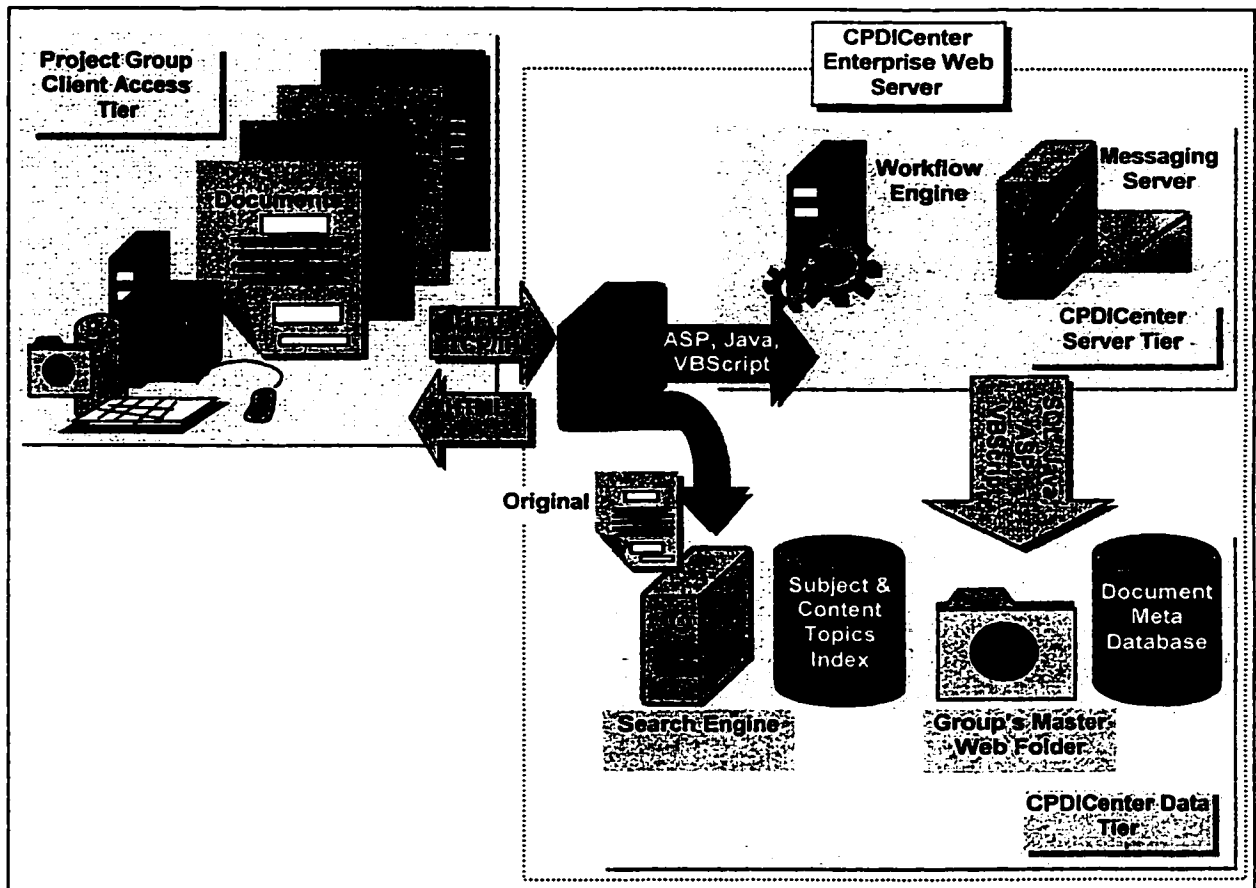

Figure-6.5: CPDICEnte Components, and The Technologies Used In Developing The Website Query Services.

6.4 – CPDIDCenter Website: Implementation and User Interface

CPDIDCenter website structure, services and logon steps are shown in Figure-6.6.

The website offers project groups two top level search options, which are:

1. Document search options, as illustrated in Figure-6.6, are possible by:
 - a. Contract, or Workpackages, or WBS, or Cost Account
 - b. Group issuing or receiving documents.
 - c. Construction site.
 - d. Document Class, Category, and Title.
 - e. Webfolder directory, folder branches.
 - f. Subjects or Keywords used to categorize documents earlier.
 - g. Claims files, and Change orders
 - h. Scheduled activities, tasks, and resources.
 - i. Project Events.
 - j. Claim Cause, Global Cause, and Damage Type.

2. Project information offers users a lookup facility about
 - a. Project sites.
 - b. Groups, and group members.
 - c. Contract Specifications, conditions, and agreements.
 - d. Cost Accounts, and Masterformat divisions used.
 - e. Weather Logs.
 - f. Site Events.
 - g. Claim files, Change Orders, and Status of issues.

Following sections will present actual snapshots from the website illustrating how documents are searched for, and the type of results or report views that are brought back to the user. Both Parametric and predefined queries (views) are supported by the CPDIDCenter Website. The example case is a highway project used for prototyping.

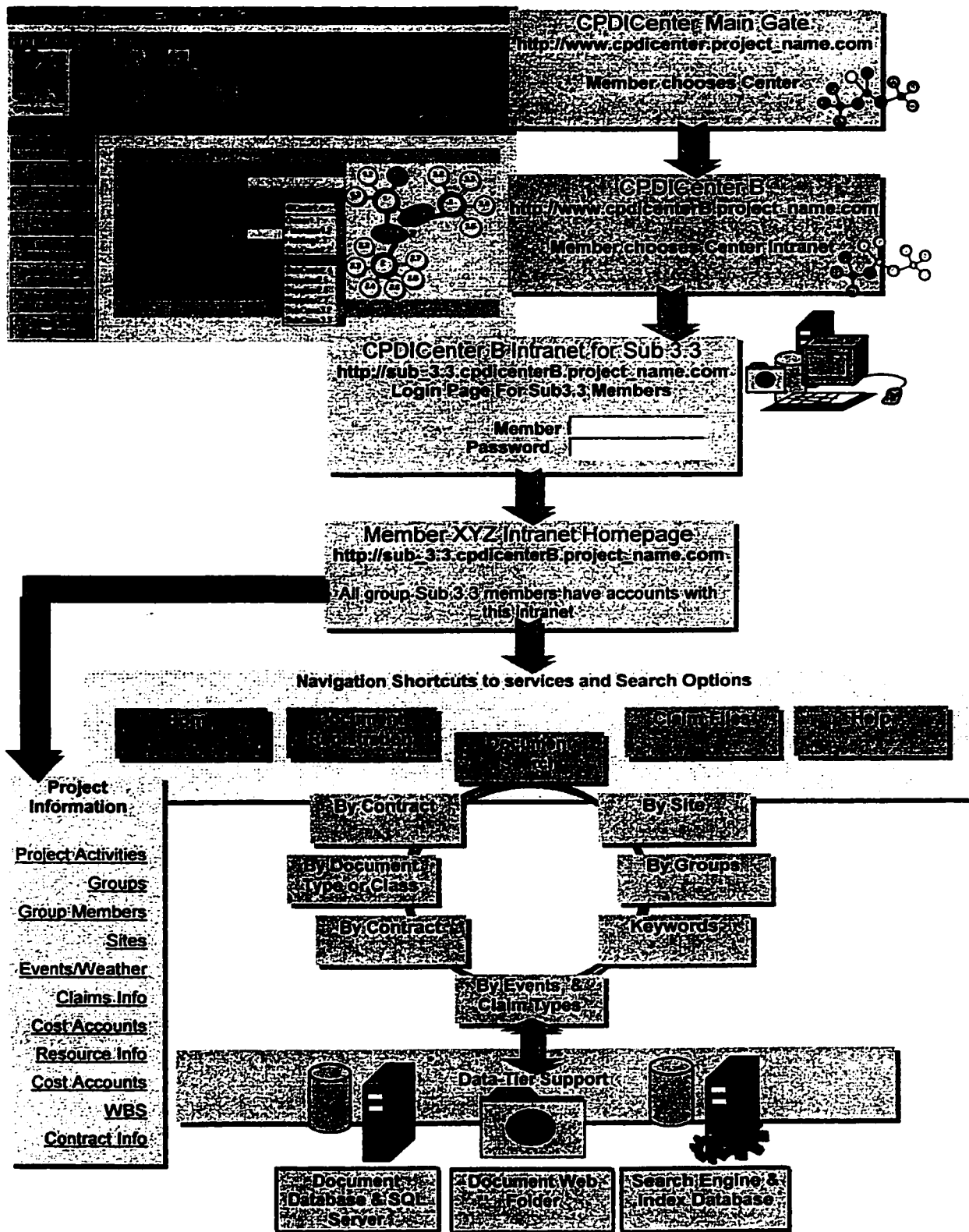

Figure-6.6: CPDICenter Logon Steps, Website Structure, Services and Search Options.

6.5 – Validation Of the System Using a Sample Case Project

The following hypothetical case project is developed in this thesis to test all components and functions (search and retrieval) of the CPDIDCenter. The components tested here include: 1) connection with the DMID, 2) searching forms, 3) registration forms, 4) search results DHTML WebPages returned by the server, 5) server, 6) hyperlinks and links to internal and external WebPages and files, 6) WebPages colour and font layouts and orientation, 7) accessibility from the internet, and 8) user login and security. All components of the DMID and CPDIDCenter functioned perfectly and satisfied their intended purpose. The hypothetical case is adapted from a sample highway project specimen, which ships with Primavera P3 to explain the P3 software functions. The hypothetical project in this thesis is linked with a set of project contract conditions and specifications requirements adapted from (FP-96 1996 “Standard Specifications For Construction of Roads and Bridges on Federal Highway Projects”) issued by the U.S Department of Transportation Federal Highway administration. The hypothetical project is intended to test, and simulate all the search and registration functions accessible via the CPDIDCenter website to refine the database design. The project is a four lane highway stretching northbound and southbound. There are 57 different construction activities, which span the life of the project. Each activity is associated with any number of cost accounts, and one WBS number. There are 34 WBS entries distributed into three levels of detail. There are 35 cost accounts associated with all activities. Each cost account is available in three versions, labour, material, and equipment. The project has a traditional organization with three main CPDIDCenters 1, 2, and 3. There are 17 groups part of this

project, distributed among three Centers—see Figure-6.7 for group information details shown directly from the RDBMS, and also as accessed via the website.

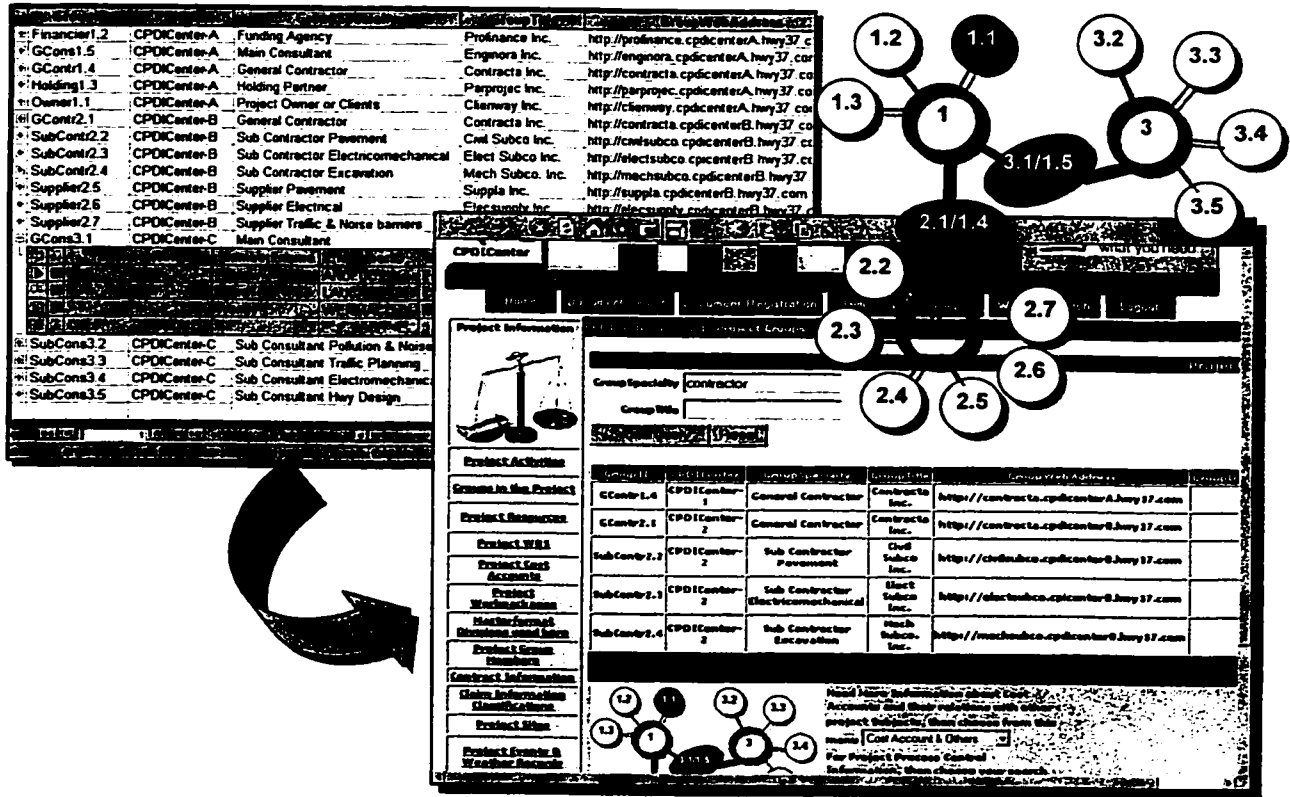

Figure-6.7: Group Information WebPages updated online from the DMID

As part of the validation process, a traditional organization is envisaged with a General Contractor (GC) who shares in centers 1 and 2. There is also a Main Consultant sharing in centers 1 and 3, with code numbers GCons 3.1, and 1.5. Moreover, there are 32 resources available. Claims information is classified using, causes (66), global causes (33), and subject keywords (166). Documents are available in four classes (Transactions: 41 Category, Proprietary: 52 Category, Public: 33 Category, and Definitions: 46 Category), and 95 titles.

6.6 – CPDICenter Search and Retrieval Services

Any registered project group member can access the services of the CPDICenter and retrieve documents. The first page a member (or user) will encounter is the Main Gate or default logon page, as shown in Figure-6.8. The main gate also presents visitors—registered project members or not—with a background information about the CPDICenter Mission, Objectives, Components, Framework, Scope of the Problem at hand, Research Objectives, Information about the developer, and the Copyright notice. For example, users can review the CPDICenter framework as depicted in Figure-6.9, or go over the components of each CPDICenter as illustrated in Figure-6.10.

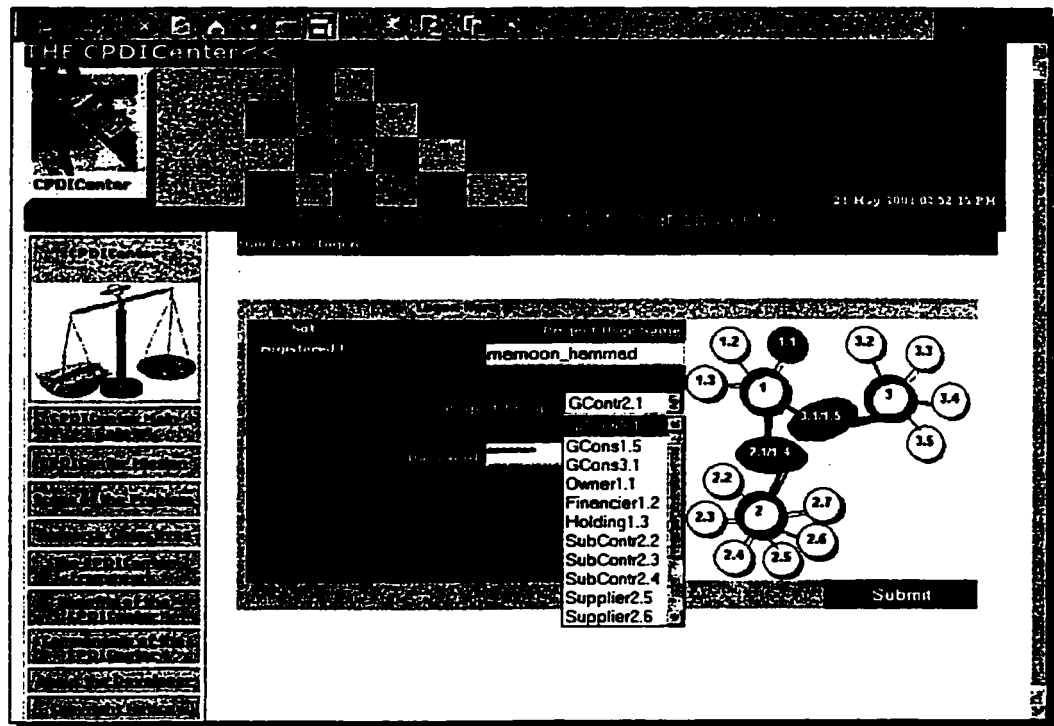

Figure-6.8: CPDICenter Main Gateway or Default User Logon Page

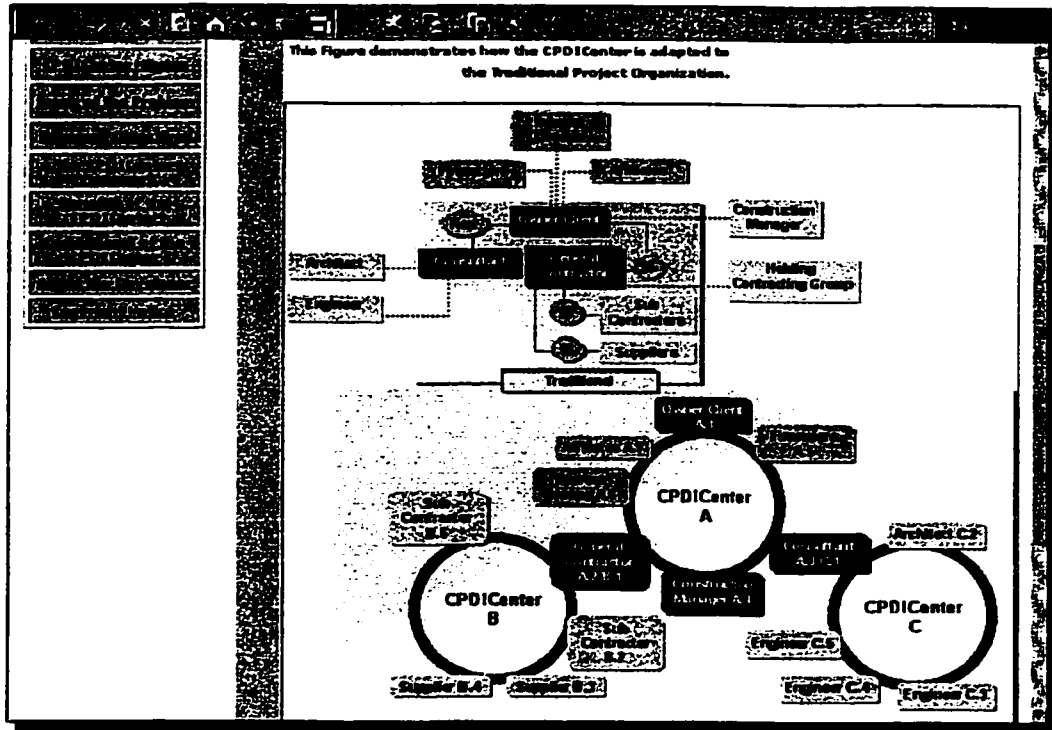

Figure-6.9: CPDICenter Framework Description Page

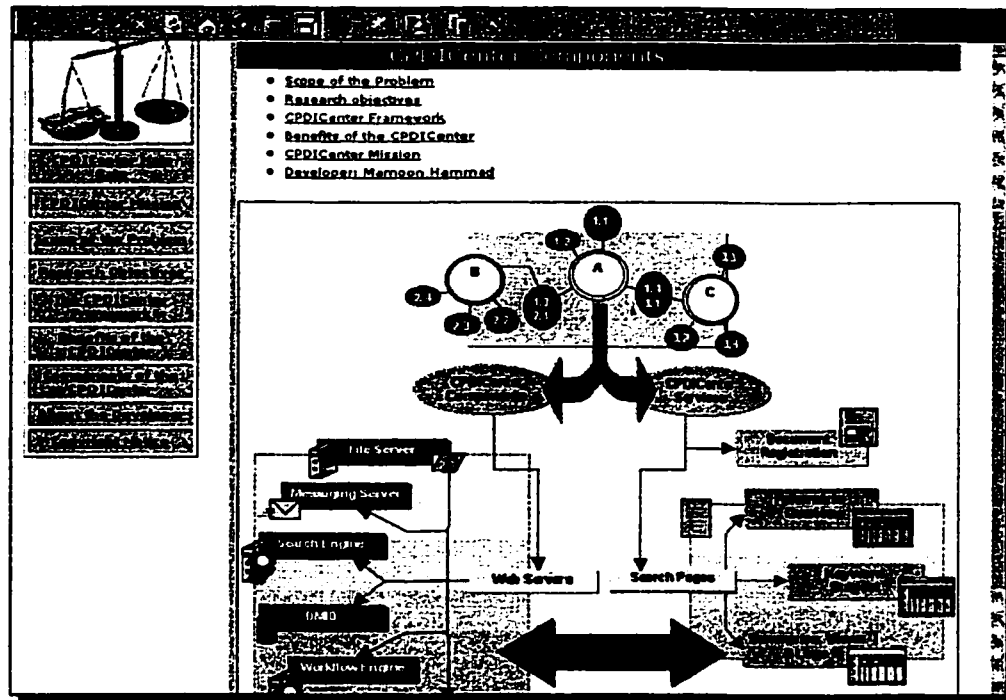

Figure-6.10: CPDICenter Components Web Page

Project members who want to register can link to a registration page from the main gate logon web page. After logging on, group members will be inside their CPDICenter group portals, Figure-6.11, where they can search for project information, register documents, lookup documents, and find information about claims. This group portal is a separate website, within the main CPDICenter, accessible only to members.

Navigation inside the member's CPDICenter portal is possible especially with the links and buttons located on Top, Side, and Bottom bars. Also users can tell where they are by looking at the location bar (below the top buttons), which is available on every page. The Top buttons offer high-level navigation to speed up access to important services, which are:

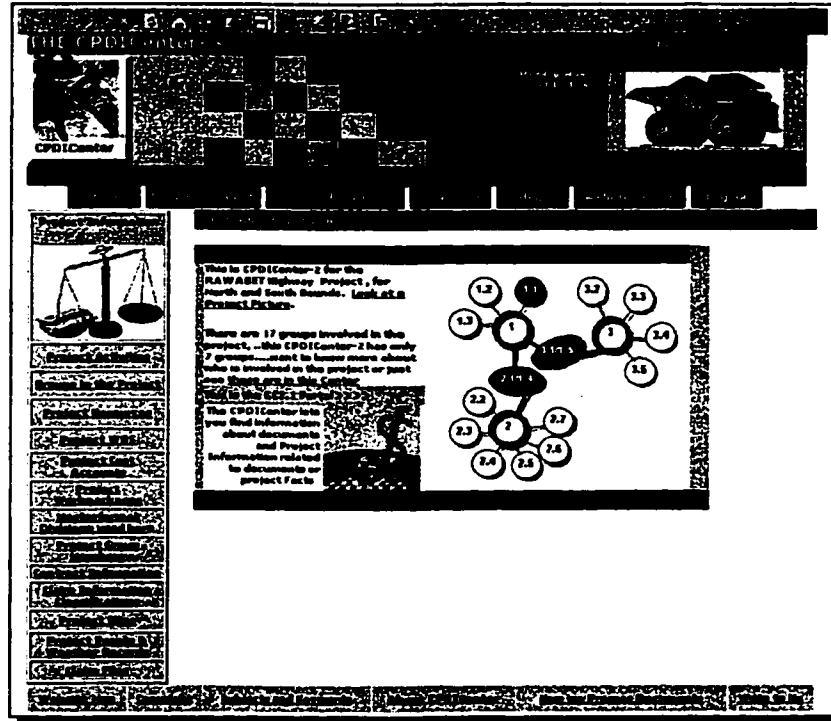

Figure-6.11: Group GC2.1 Member Portal User Interface For Cpdicenter-2.

1. **Home Link** (brings the user back to the default portal page).
2. **Document Search**: offers search in a variety of ways.
3. **Document Registration**: guides the user through the document registration steps and allows review of newly added document records.
4. **Claim Files**: offers exclusive search of claim files and associated data.
5. **Help**: allows users to give their feedback and report website problems.
6. **Website Search**: Offers Boolean searches of the Website Pages and Website contents.
7. **Logout**: this link takes the member back to the main gate, and closes the CPDIDCenter session.

The side bar on the other hand assists members navigate directly to project information, such as: Project activities, Project Groups and Members, Project Resources, WBS, Cost Accounts, Workpackages, Masterformat divisions, Contract information, Claim information and Classifications, Sites, Events, and Weather records. Further detailed information is also provided once the members follow through with a link. Those project information links assist users in two functions. First, while registering documents since they might need to lookup project data. Secondly, while searching for documents, in order to narrow down the search. The Bottom bar has links to less visited pages like Website Map, Copyright, Keywords and topic hierarchies, Document Processing steps, and Website administration.

6.6.1 – Document Submissions and Registration in the CPDIDCenter

Document registration steps are demonstrated in Figure-6.12, and shows how documents' information is processed and added to the DMID for future search and

retrieval. Any project member can register a document. Registration is a four-step procedure intended to streamline all document additions to the DMID. In a fully automated setting, this information becomes part of the digital document form.

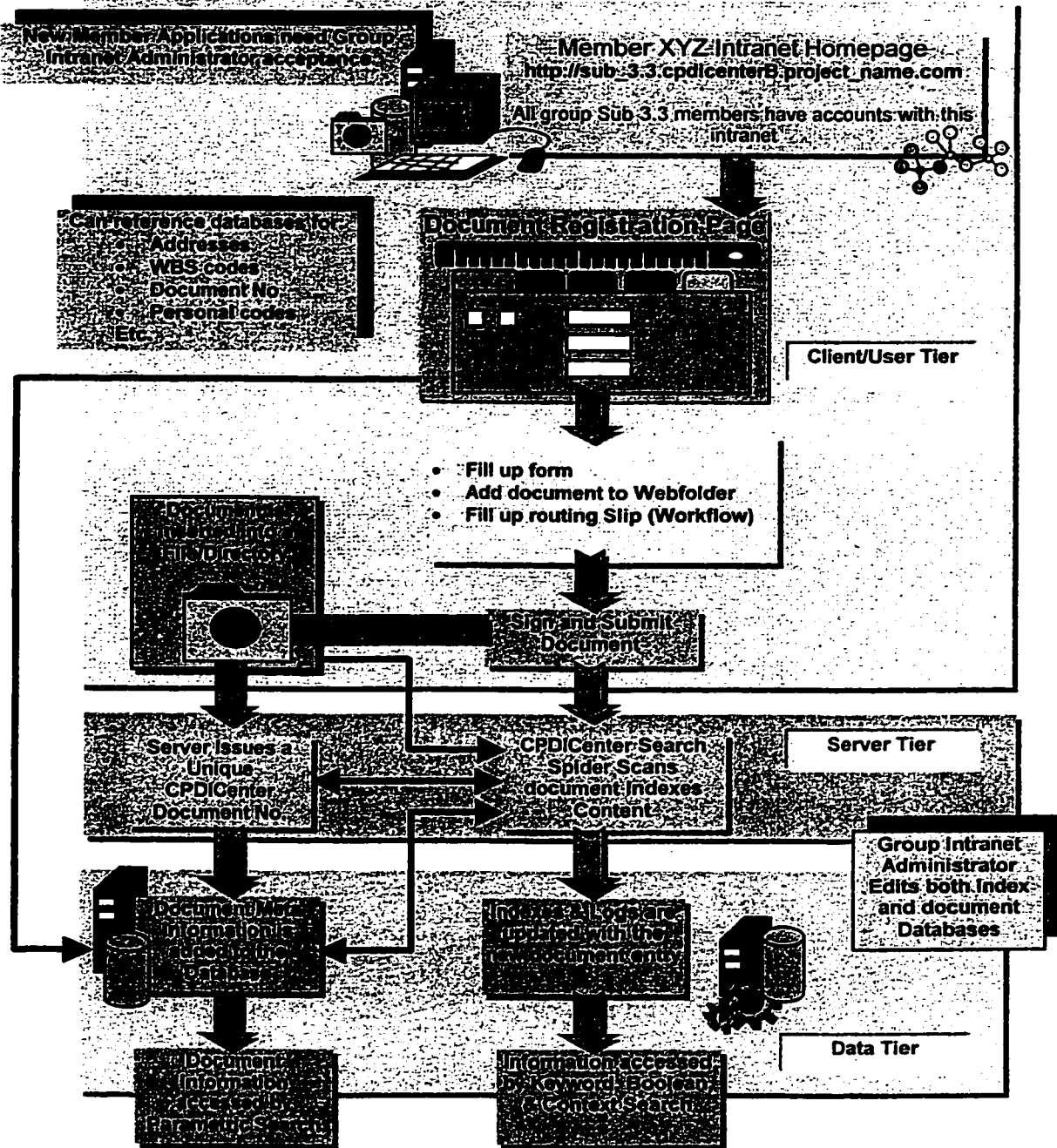

Figure-6.12: Document Registration Steps, and Document Information Processing.

Once filled by a user, the document information is reconciled with the DMID data structure. Figure-6.13 shows the first document registration step (workflow information).

The screenshot displays a web application interface for document registration. On the left is a vertical navigation menu with a scales icon at the top. The main content area features a header with a logo and a navigation bar with links like 'Home', 'Registration', 'Search', and 'Logout'. Below the header is a large text block. The central part of the page is titled 'Document Registration' and contains a form with the following fields:

- Issue Date: 10/05/2001
- Period: From 02/04/2001 To 10/05/2001
- Group Issuing: GCONF214740
- Member ID: Member002
- Distributed To: GCONF1145224, GCONF1145224, GCONF1145224
- Must Reply by: 17/05/2001, and this is time sensitive because [redacted]
- The Subject Matter is: [redacted]
- This document has this Access Right: [redacted]
- Document Version No.: [redacted], Revision No.: [redacted], Original Document ID: 2421145224

Figure-6.13: Registration Step-1 for Document Workflow information

Then the group member goes on with the other remaining steps as shown in Figures-6.14, 6.15, and 6.16.

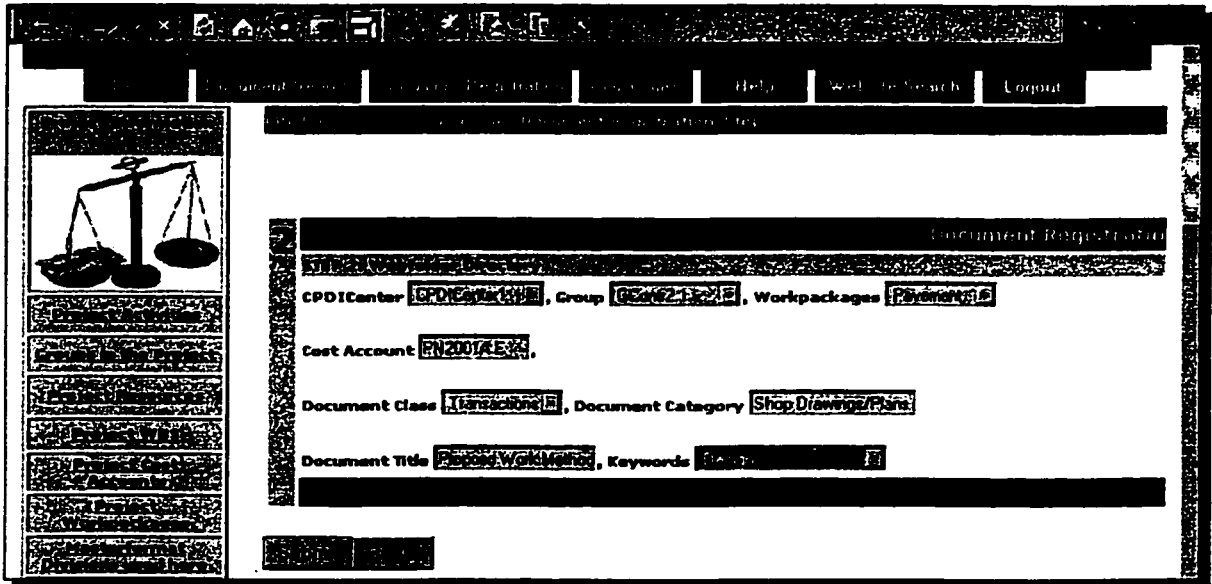

Figure-6.14: Registration Step-2 for Document Webfolder Directory Allocation

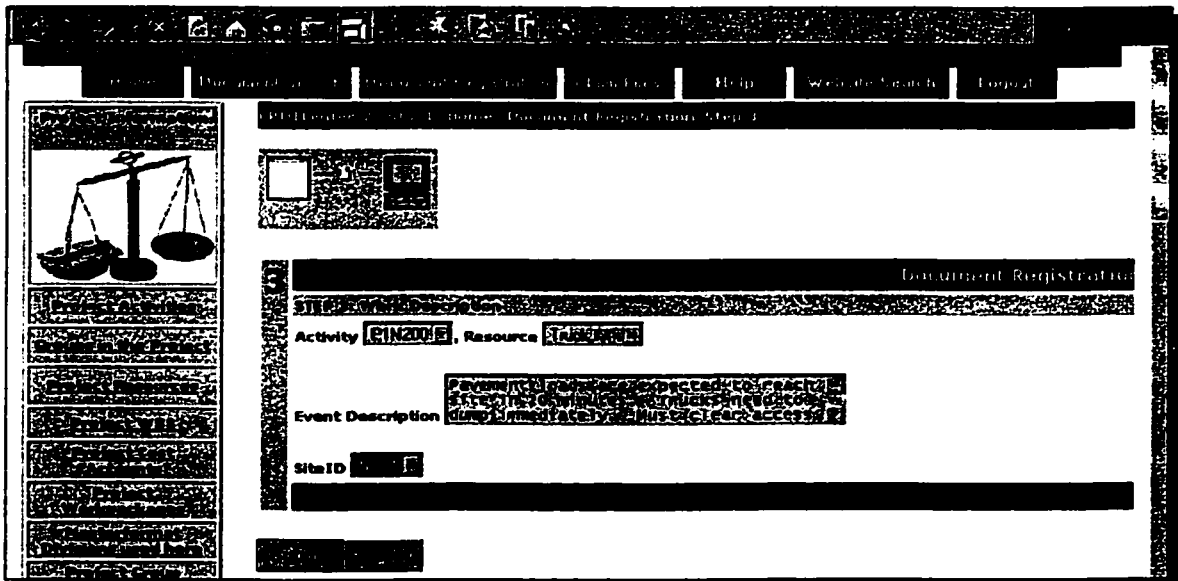

Figure-6.15: Step-3 Work Description part of the Document Registration Process

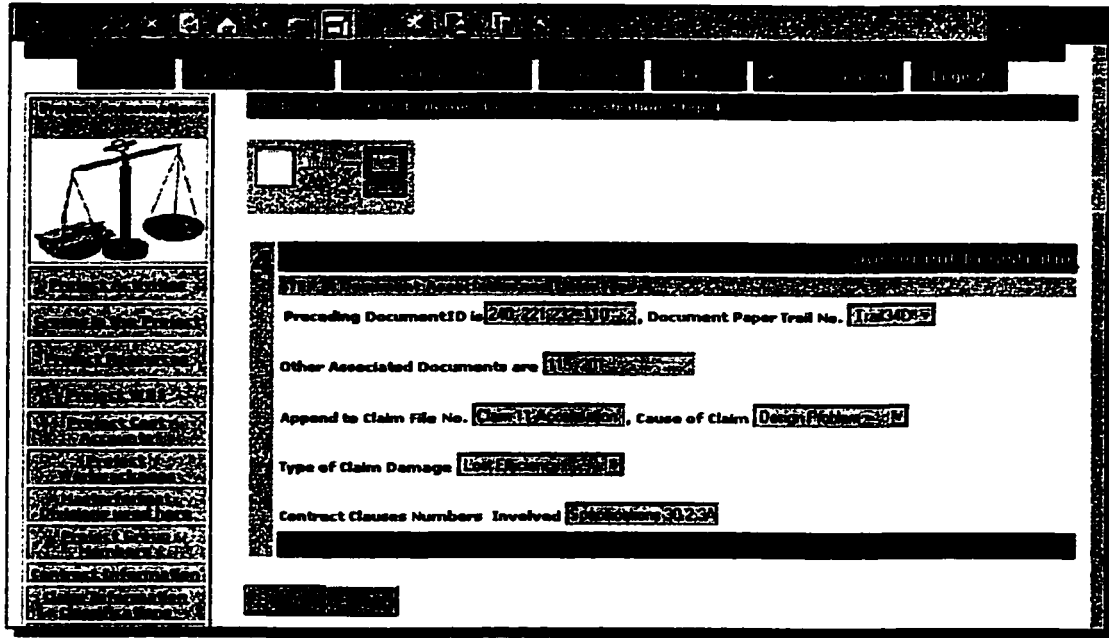

Figure-6.16: Registration Step-4 (Last) For Document Referencing and Association.

After registering a document, a confirmation page brings back to the user all documents registered in that session, shown here in Figure-6.17. This confirmation page shows the information that is inserted for every document added to the group's Webfolder and the DMID. Registration collects data about document workflow, work description, claims information, and document cross-referencing.

ID	issue_date	period_start	period_to	group_issuing	member_id	group_receiving1	group_receiving2	group_receiving3	issue
1	01/01/2000	01/01/2000	01/01/2000	GContr1.4	6 letter ID	GContr1.4	SubCont2.4	Holding1.3	03
2	01/01/2000	01/01/2000	01/01/2000	SubCont2.2	6 letter ID	Holding1.3	GCons1.5	SubCont2.4	03
3	01/01/2000	01/01/2000	01/01/2000	Group Issuing	6 letter ID	GCons1.5	SubCont2.2	Supplier2.5	03
4	02/10/2000	10/09/2000	01/11/2000	GContr2.1	MAMHAM	GCons1.5	Consult3.2	Consult3.5	10
5	10/05/2001	02/04/2001	10/05/2001	GContr2.1	mamham	Owner1.1	GCons1.5	GCons3.1	10

ID	Center	Group	Workpackage	CostAccount	DocClass	Category	Title	Keywords
1	CPDI Center2	SubCont2.3	Signals	PN100150E	Definitions	e.g. Plans, Requests	e.g. RFI, Proposal	Delay
2	CPDI Center2	GContr2.1	Mechanical	PN0225E, PN0225M	Transactions	Plans, Requests	RFI	Equipm-
3	CPDI Center1	GContr2.1	Pavement	PN2001A E	Transactions	Shop Drawings/Plans	Proposed Work Method	Design
4	CPDI Center2	SubCont2.2	Signals	PN115 M	Transactions	Material Catalogues	Proposed new Material	Propos
5	CPDI Center2	Supplier2.6	Excavation	PN213 31 M	Transactions	Soil Reports	Laboratory Tests	Qualit

ID	Activity	Resource	EventDescription	SiteID
1	P1N050	Mechanic	Meeting with Subcontractor site group	NS01
2	P1N150	Mechanic	Stoppage for redesign of HVAC tracks	NS01
3	P1N200	Truck	Access to Pavers was restricted by subs	NS01
4	P2N120	Electrician	Proposed new Material is Provided for acceptance	NS01
5	P2N300	Loader	Soil Tests to be used in planning hauling	SN01

ID	DocPreceding	DocPaperTrail	DocAssociated	ClaimFileNo	ClaimCause	ClaimDamage	Comments
1	35,45,12	Trail2A	14,102,221	Change2B/C	Owner Interference	Lost Productivity	1011 Chang
2	Doc45/Civil	Trail34D	Doc44/Mech	Delay07/NS01	Design Problem	Delay	Condition 235
3	240, 221,232, 110	Trail34D	113, 201	Claim 11-Acceleration	Design Problem	Lost Efficiency	Specificati
4	106	Trail71A	71,241	Claim 84-Changes	Additions	Waiting for Decision	Specificati
5	75,32	Trail1B	41, 76, 931	No Claim	Material	Inflation	Specificati

Figure-6.17: Document Registration Results are displayed as recorded in the Database.

Current file servers are supposed to track registered documents if they are moved between directories. Hence, each document should get a UNC (Universal Naming Convention instead of drive letters which often change) location address by the server at the time of registration, and for every consecutive move/transfer, the UNC is updated. The UNC address format is: [///file_server_name/volume_drive_alias/path/file_name]. Some examples are similar to:

1. ///Transactions/WP#22/CA#23/Payments/Payment_Requests/PR#22.Ex
2. ///Public/WP#11A/CA#9C/Meetings/Meeting_Agenda2B.Doc

6.7 – Search and Retrieval of Documents and Information

6.7.1 – Document Search Examples

The Document search gateway in Figure-6.18, which is accessible via the Document Search button in top bar, allows users to find documents by a variety of search options: 1) by document class (Transactions, Definitions, Proprietary, and Public), 2) by claim file, 3) in association with change orders, 4) by keywords, 5) by precedence or paper trail, 6) by activity, 7) by cost account, 8) by distribution, and 8) by the sort of comments or annotations found with any document. These are but few of other available options that allow the user to find documents by any data identifying that document like date of issuance, group name, site, activity, contract...etc.

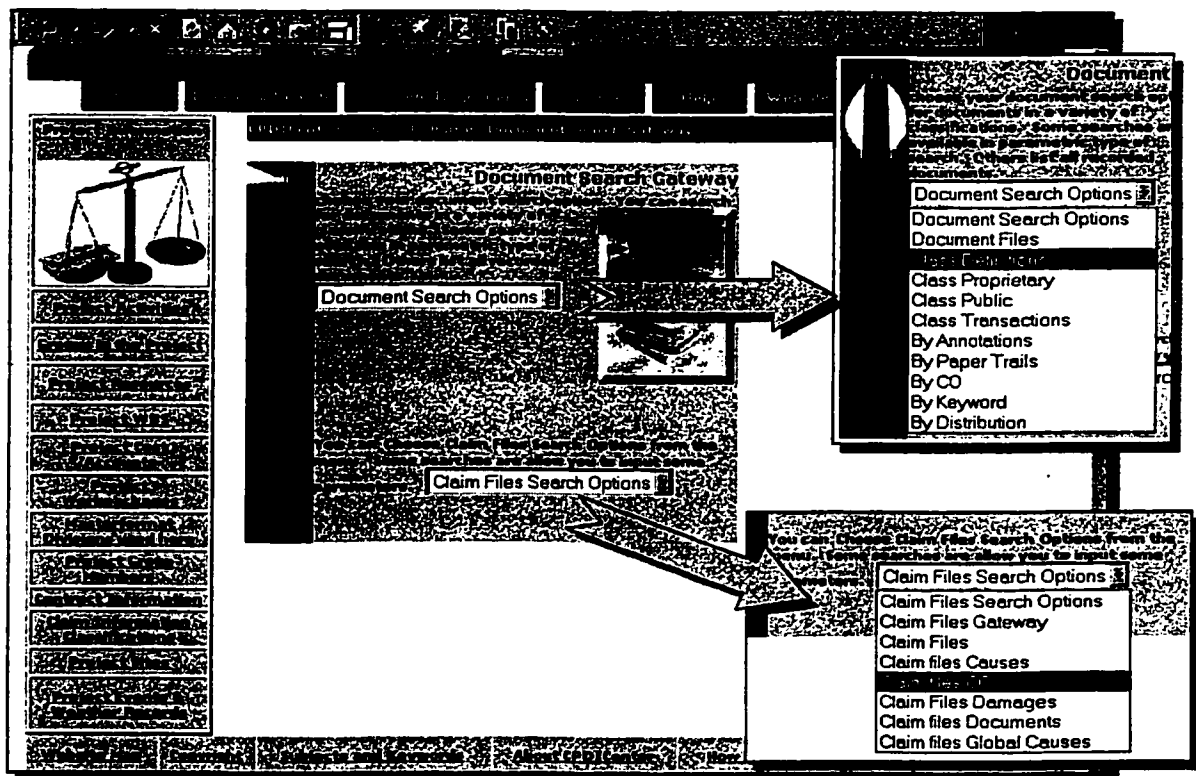

Figure-6.18: Documents and Claims Search Options in the CPDICenter.

An example from the document files search page is presented in Figure-6.19, for project members to lookup documents by activity, group, member, or comments. In addition those documents are arranged by date, activity, and cost account.

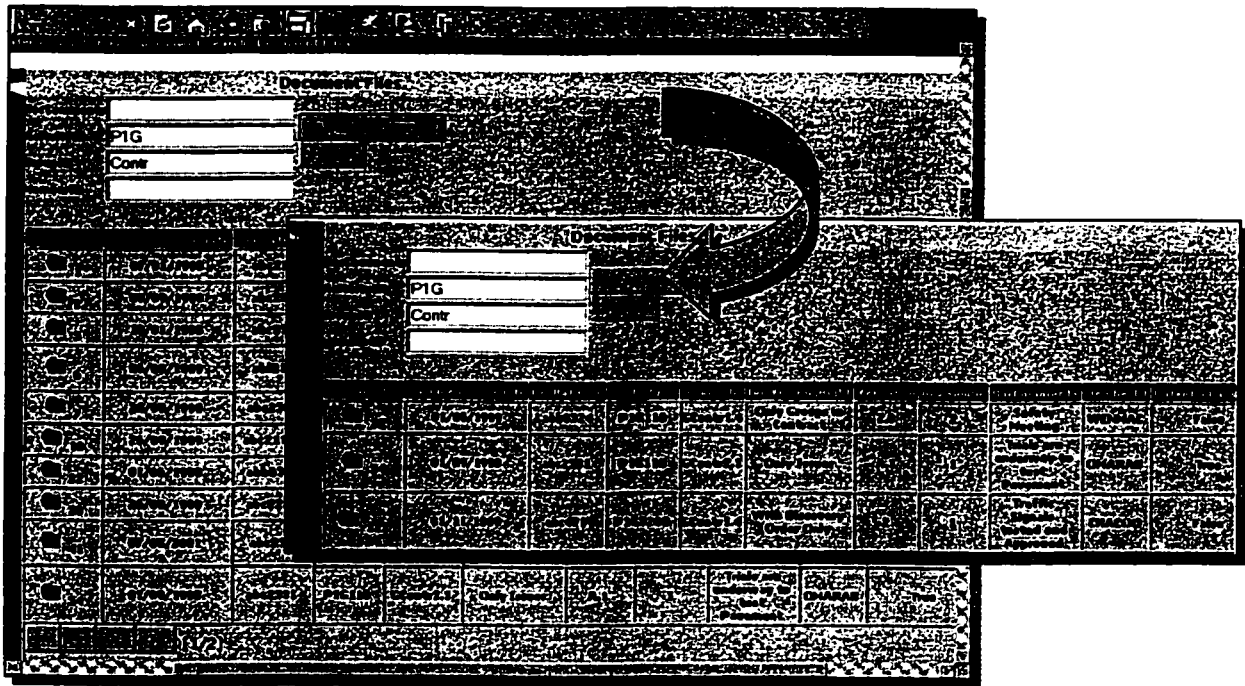

Figure-6.19: Search Results for documents Issued by contractors working on P1G.

Searching directories inside group Webfolders is also possible, because documents are already distributed between four CPDIDCenter classes (Transactions, Proprietary, Public, and Definitions). Hence, one can search in any class directory, as illustrated by Figure-6.20 for a Transactions Class, and Figure-6.21, for a Definitions Class type of search. More search options include searching by change order files as in Figure-6.22 and searching for documents by keywords or topic hierarchies as in Figure-6.23.

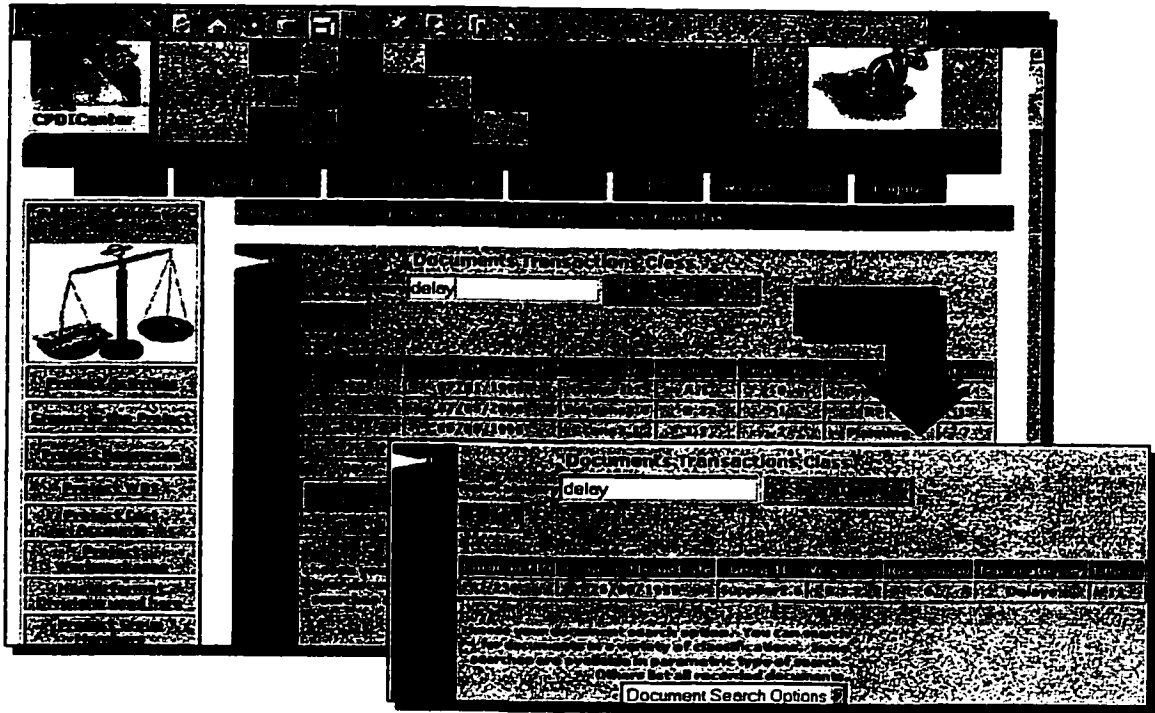

Figure-6.20: A Search example in the Transactions directory for delay documents.

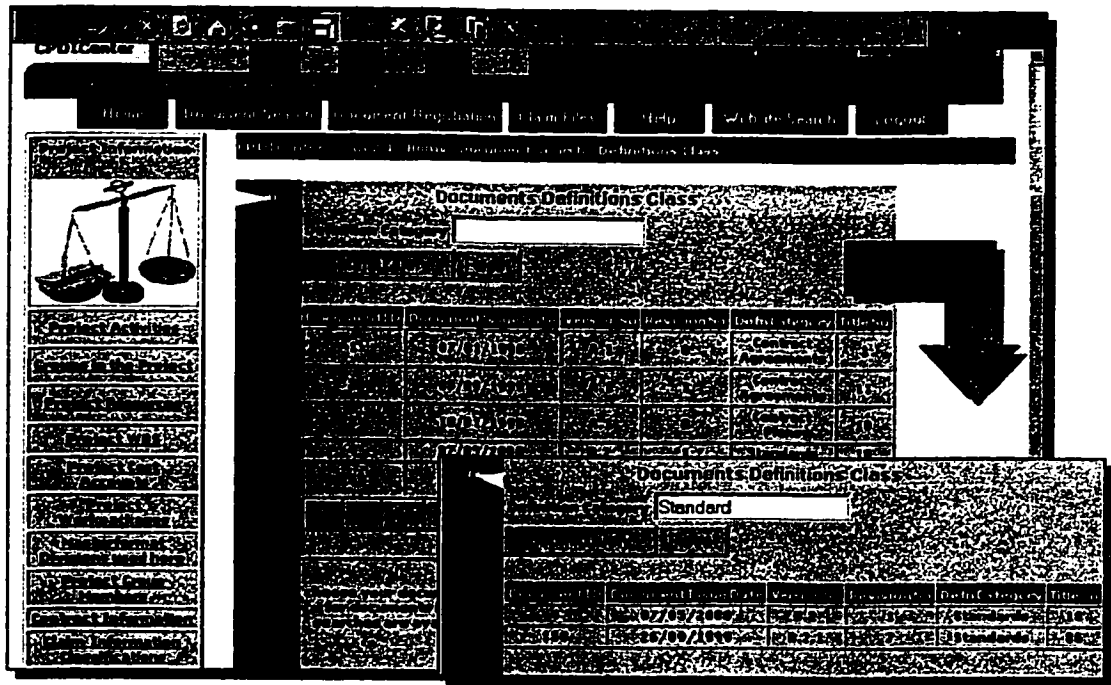

Figure-6.21: A Definitions directory search for Documents of category Standard.

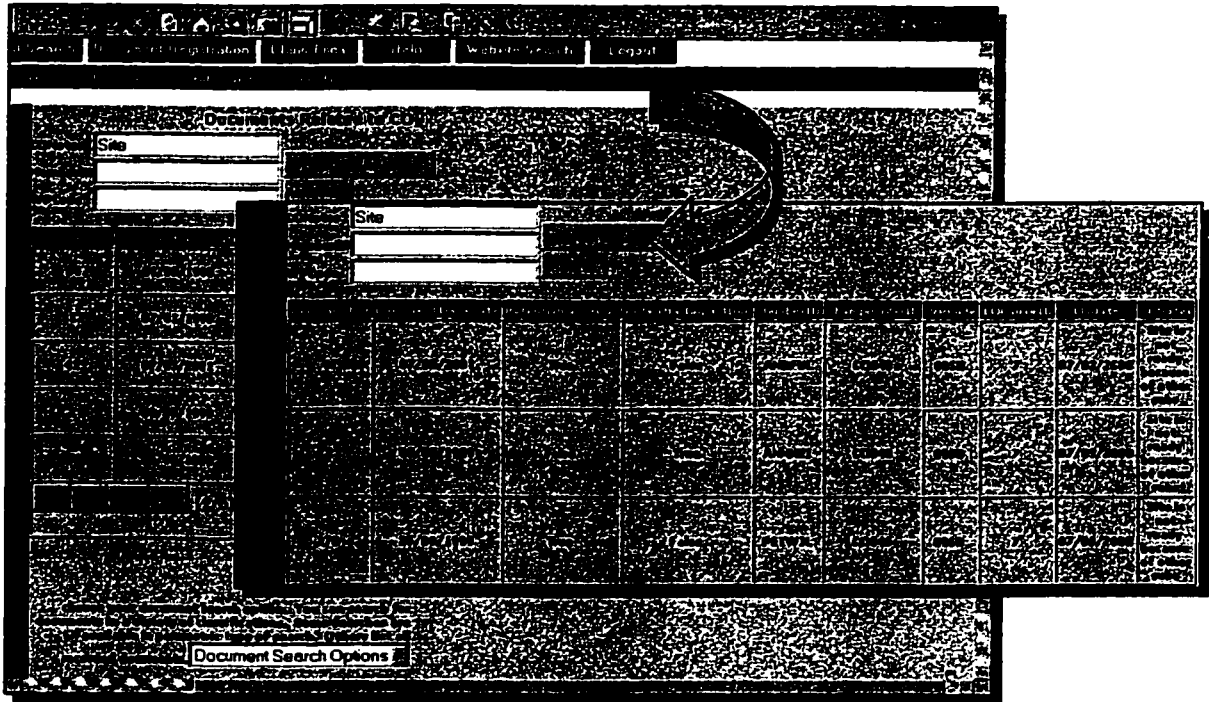

Figure-6.22: Search results for documents associated with Site-Caused C.O.

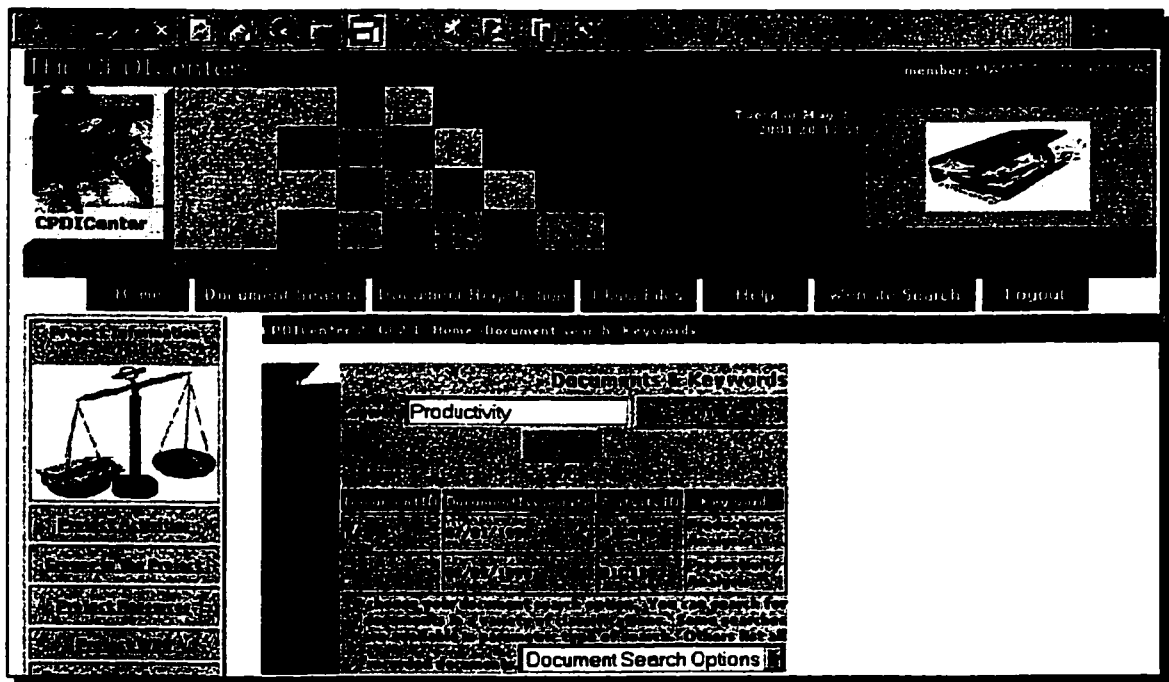

Figure-6.23: Search Results for Documents Associated with Keyword Productivity

Another option for users is to find what annotations been attached to a file; this is depicted in Figure-6.24. If annotations are extensive enough to change a document, that document is rendered a new version or revision of the original document.

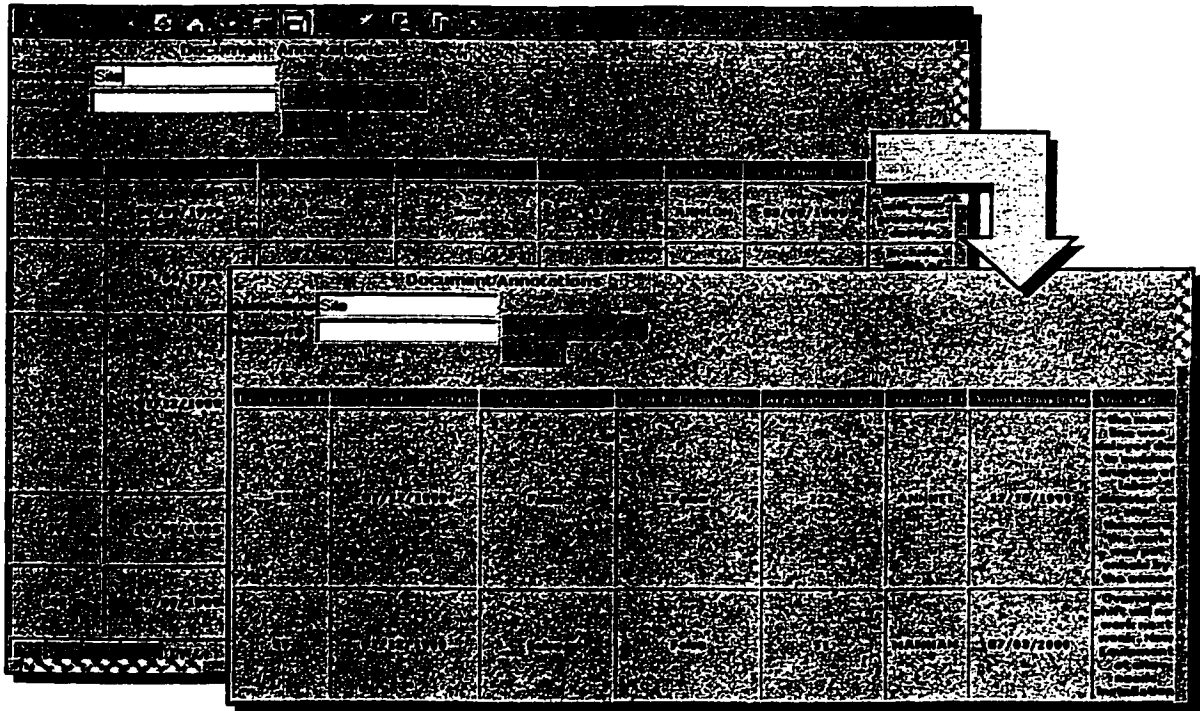

Figure-6.24: Search documents with Annotations about Site.

Paper trails are another concern to anyone searching for documents to support a claim issue. Earlier in this research, sequence diagrams have been used to illustrate how paper trails or document trails are modeled using Sequence Diagrams. In Figure-6.25 the CPDICenter offers this search option, and lets the user lookup documents that are cross-referencing each other.

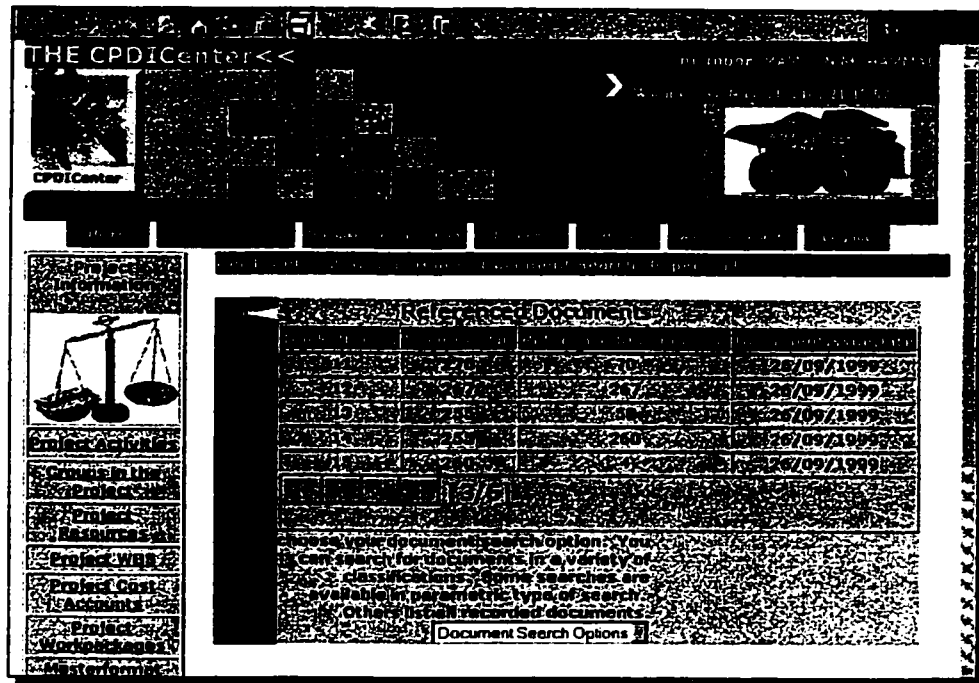

Figure-6.25: Paper Trails Search of Documents Referencing Other Documents

6.7.2 – Claim Files search Examples

Claim files search facility offers different ways to locate a claim file or its associated documentary proof. As in Figure-6.26, the user would learn about claims by visiting the claim files gateway page, and choose to find information about 1) claims' files, 2) find claims by cause, 3) by damage type, or 4) by a global cause, and 5) there is also a page to locate all documents associated with any claim.

Claim files page is shown in Figure-6.27 depicting an example in which the user is trying to find any claim files with a Status equals to Rejected.

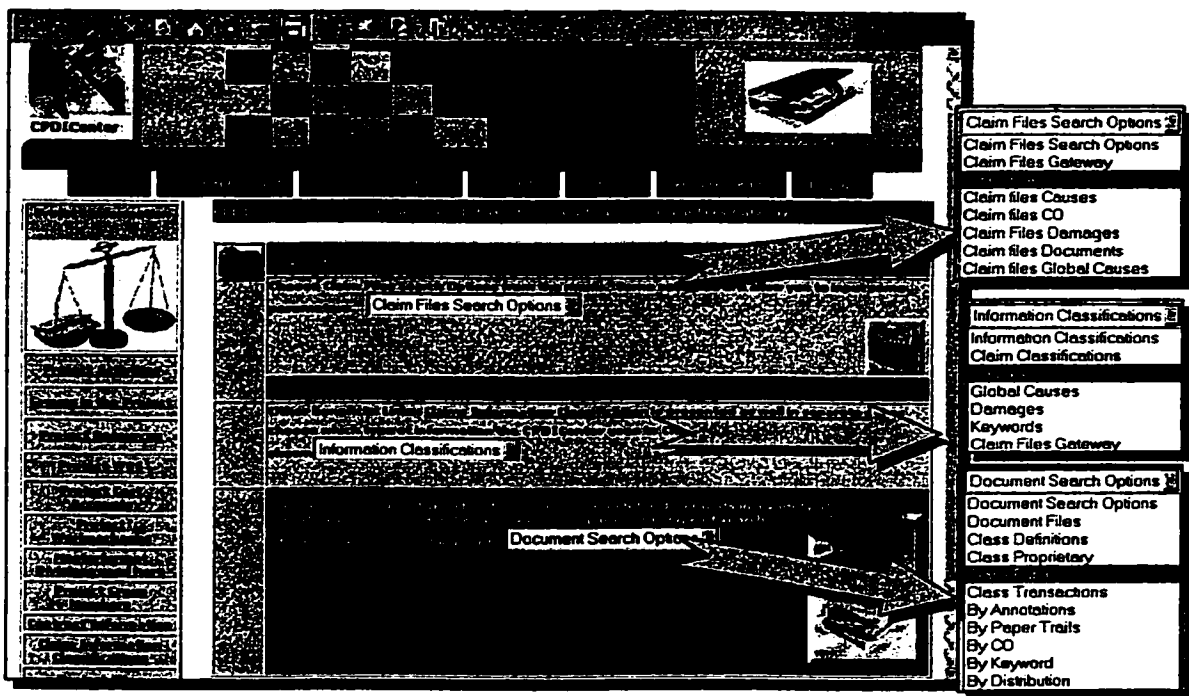

Figure-6.26: Claim Files Search Options, and Claims Classifications WebPages.

Claim files include date information, groups involved, subject matter, any comments or notes about the situation, and estimates of its cost. Searching by a claim cause is listed in Figure-6.28 for an example search for claims caused by a quality problem. A search for claims related to Acceleration Damages returned the results shown in Figure-6.29. While in Figure-6.30 the user was able to locate all registered documents affiliated with a claim for Acceleration.

Claims' search pages present a wealth of information about any claim file, including things like the site it took place at, activities involved, workpackages, groups affected, claims' status, dates, damage estimates, and actual cost of changes.

Claim Number	Claim Type	Claim Date	Claim Status	Claim Description	Claim Received By	Claim Notes
	Contract Disputes	11/17/2000	Rejected By Owner		Sub Contract	
	Contract Disputes	08/04/2000	Rejected By Owner		Sub Contract	Owner L.I.
	Contract Disputes	08/09/2000	Rejected By Owner		Sub Contract	Owner L.I.
	Contract Disputes	01/05/2000	Rejected By Owner		Sub Contract	Owner L.I.
	Contract Disputes	01/09/2000	Rejected By Owner		Sub Contract	Owner L.I.
	Contract Disputes	01/09/2000	Rejected By Owner		Sub Contract	Safety conditions must be protected

Figure-6.27: Results for a Search for Claim Files That have been rejected.

Claim Number	Claim Type	Claim Date	Claim Status	Claim Description	Claim Received By	Claim Notes
	Contract Disputes	07/05/2000	Rejected By Owner		Sub Contract	Owner L.I.
	Contract Disputes	07/05/2000	Rejected By Owner		Sub Contract	Owner L.I.
	Contract Disputes	07/05/2000	Rejected By Owner		Sub Contract	Owner L.I.

Figure-6.28: Looking Up Claims caused by issues related to Quality

6.7.4 – CPDICenter Project Information Search Pages

Project information presents the searcher with contextual background and facts about the construction operation or process, the people involved, and the resources used. It also brings up-to-date information about work sites, events, weather records, calendars, and the status of many issues. Members using the CPDICenter can retrieve activity information as shown in Figure-6.33, which brings on screen all activities at site GCO1 and with the words Place Temp in the activities' descriptions.

Activity ID	Activity Description	Activity Type	Start	End	Duration	Cost
P1C090	BEGIN PROJECT	Start	23/0			
P1C100	MOBILIZATION	Task	23/0			
P1C103	CLEAR SITE	Independent	23/0			
P1C110	GENERAL CONDITIONS	Task	10/0			
P1C200	PROCUREMENT OF ESW/SI SIGNS	Task	10/1			
P1C320	CONSTRUCT CONCRETE BARRIER AGAINST WALL	Task	23/0			
P1N1140	PLACE TEMP. MARKING TAPE	Task	03/0			
P1N1145	PLACE TEMP. CONST. BARRIER	Task	04/0			
P1N1150	EXCAVATE	Task	20/0			
P1N1170	PLACE AGGREGATE & ASPHALT BASE COURSE	Task	14/0			
P1N1180	REMOVE TEMP. CONST. BARRIER	Task	20/0			
P1N1183	PLACE 2" SURFACE COURSE	Task	07/0			
P1N1190	DIVERT TRAFFIC ONTO TEMP. ROAD	Task	20/0			
P1N1193	REMOVE TEMP. MARKING TAPE	Task	01/0			
P1N1200	PLACE CONST.	Task	17/0			

Activity ID	Activity Description	Activity Type	Start	End	Duration	Cost
P1N1140	PLACE TEMP. MARKING TAPE	Task	03/06/1999	03/06/1999	1	03/06/1999 GCO1 A.01.5
P1N1145	PLACE TEMP. CONST. BARRIER	Task	04/06/1999	04/06/1999	1	04/06/1999 GCO1 A.02.7
P1N1240	PLACE TEMP. STRIPING & DIVERT TRAFFIC	Task	20/05/1999	20/05/1999	1	20/05/1999 GCO1 A.02.1
P2N0100	PLACE TEMP. CONST. BARRIER	Task	20/05/2001	20/05/2001	6	20/05/2001 SNO1 A.02.3.100

Figure-6.33: Search Results for Activities at Site GCO1 with Place Temp in their Descriptions.

Further details of those activities and their cost accounts, resources they employ, estimated budgets, WBS and workpackages are also provided in special search pages inside the CPDICenter, illustrated here in Figures-6.34 and 6.35. Figure-6.34 retrieved

that information for activities starting with P1G. In Figure-6.35, all activities using the resource type Dozer are retrieved with their cost accounts.

Activity ID Contains PIG

PIG000	A.01.0	0	0.00	0.00
PIG100	A.01.5	015300 C	100.00	0.00
PIG105	A.01.5	021100 E	3030.00	4.00
PIG105	A.01.5	021100 L	372.00	24.00
PIG105	A.01.5	021100 L	101.20	0.00
PIG110	A.01.0	010100 C	10500.00	0.00
PIG200	A.02.3.000	020400 M	22000.00	0.00
PIG200	A.02.3.100	023100 L	322.50	16.00
PIG200	A.02.3.100	023100 E	304.00	16.00
PIG200	A.02.3.100	023100 L	2976.00	102.00
PIG200	A.02.3.100	023100 L	3040.00	102.00
PIG200	A.02.3.100	023100 M	7200.00	00.00

Figure-6.34: Search for Budget, Cost Accounts, WBS, & Quantity Information related to Activities that Start with the Letters PIG.

Resource Name Contains Dozer

PIG105	021100 E	DOZER
PIG105	021100 L	FOREMAN
PIG105	021100 L	LABOR-C
PIG200	023100 E	VIBRATOR
PIG200	023100 L	FINISHER
PIG200	023100 L	FOREMAN
PIG200	023100 L	LABOR-C
PIG200	023100 M	CONCRETE
PIN1140	015300 L	FOREMAN
PIN1140	015300 L	LABOR-C
PIN1145	015300 E	CRANE
PIN1145	015300 L	FOREMAN
PIN1145	015300 L	LABOR-C
PIN1145	015300 L	OPERATOR
PIN1150	022250 E	LOADER
PIN1150	022250 L	FOREMAN
PIN1150	022250 L	LABOR-C

Figure-6.35: Cost Accounts for Activities using Resource Type Dozer.

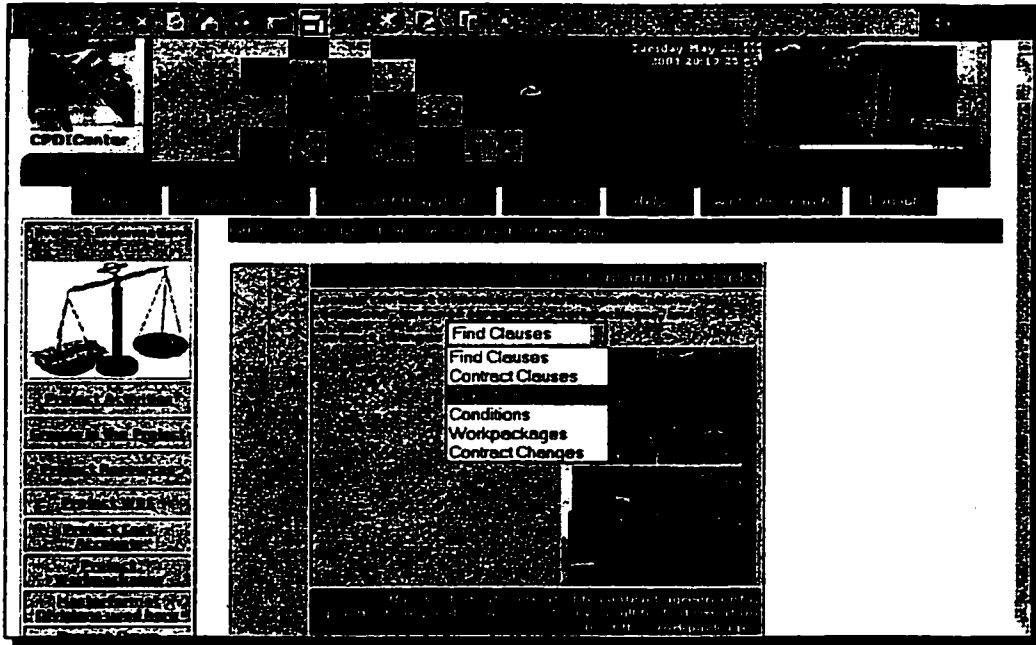

Figure-6.37: Search Options for Contract Information inside the CPD Center

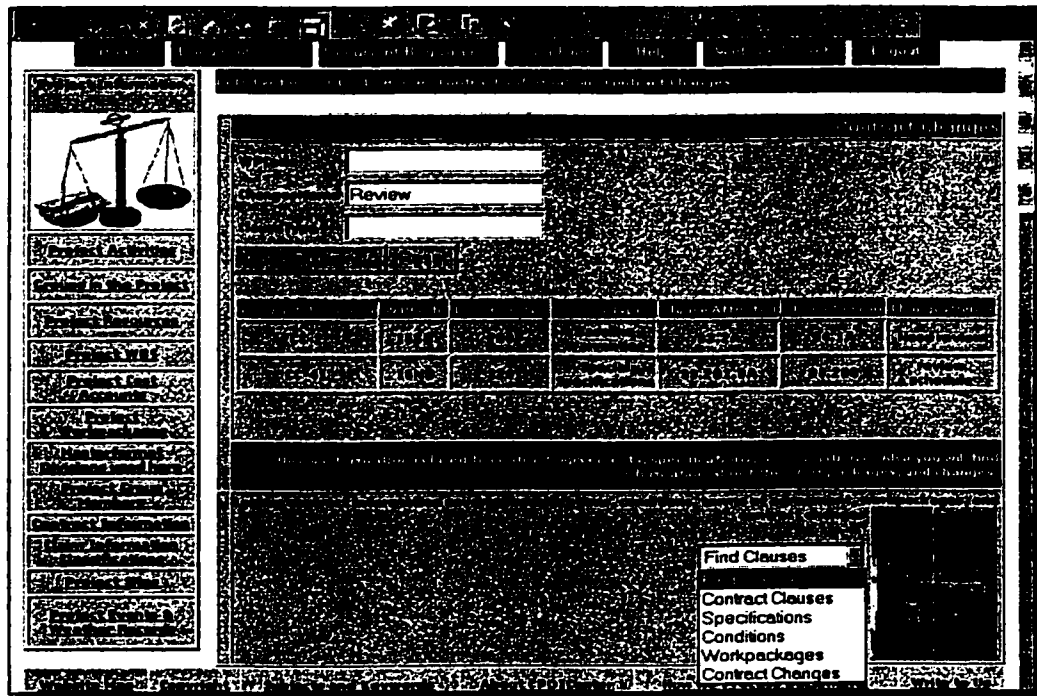

Figure-6.38: Retrieving Information about Contract Changes that have Review in their Memo Field. Shows Affected Documents, and Clauses.

Project events are presented in Figure-6.39, with search options like a search by keyword, by site, by activity, and weather records. Users will be able to find event files and check their details as in Figure-6.40, which lists all events that took place at site NSO1 and with the word Stop in their description. Event information includes references to sites, dates, documents, and weather information.

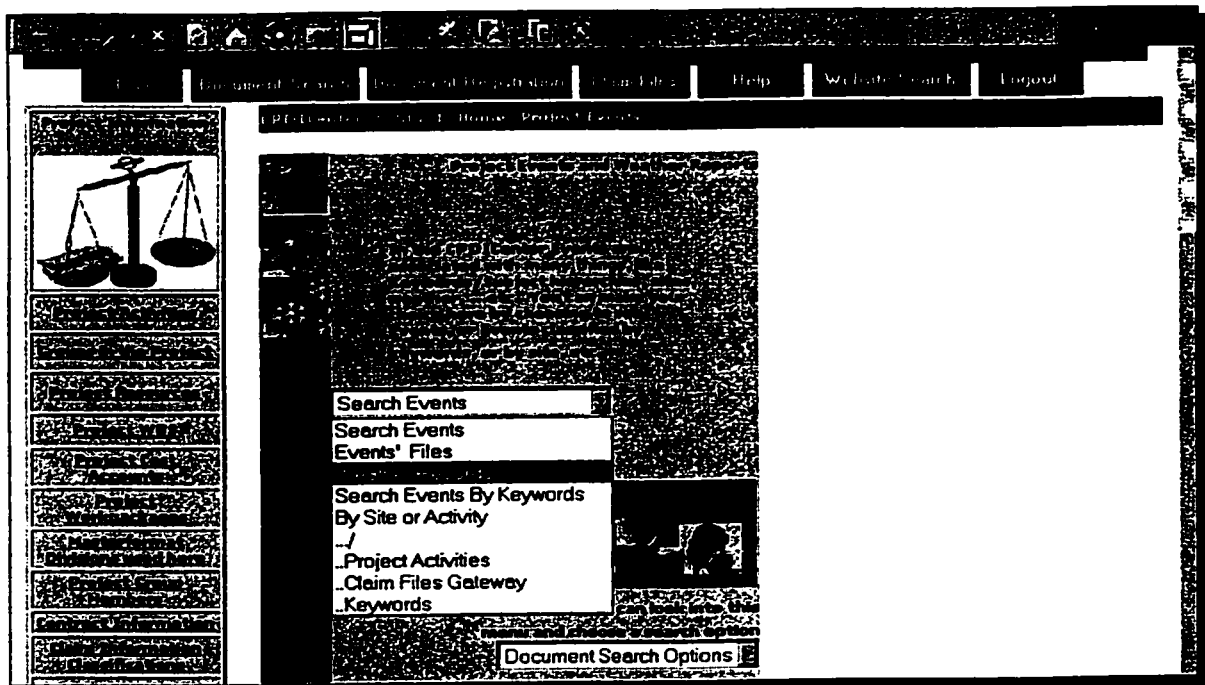

Figure-6.39: Project Events Search Alternatives in the Select Menu

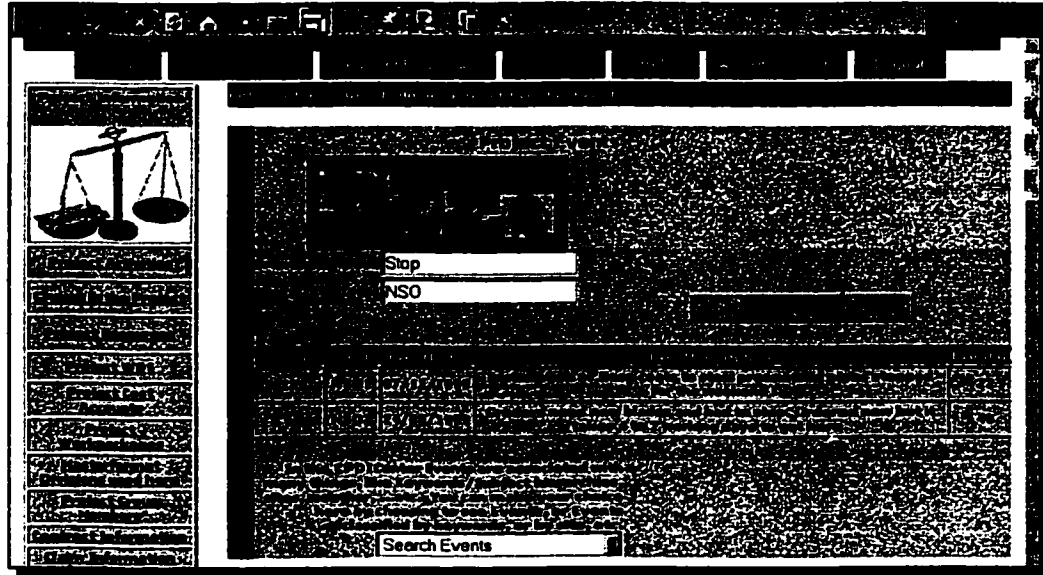

Figure-6.40: Search results for Project Events that match the Criteria: SiteID="NSO1", and Event Description="Stop".

6.8 – Prototype Validation comments

The foregoing testing of all search and registration functions purpose was to ensure that the expected or intended set of documents, especially when searching with a pretext or search parameters, are returned to the user. The interaction with the DMID worked well, and whenever a new set of document information or document records are added, the user was able to find the latest updates immediately. All document search functions for: claim files, contract information, project information, and indexing values, worked and returned accurate data. Search by association of documents with changes, and project information resulted in documents that are truly related to the issues or events at hand. Paper trails are also generated using the search form for documents related to other documents. The functions of search, retrieval, and document registration all worked as planned and satisfied cross-referencing requirements.



Chapter Seven *Conclusions and Recommendations for Future Work*

7.1 – *Conclusions*

In conclusion, the construction industry relies on contemporaneous documents for supporting claims negotiations, arbitration, or litigation. Contracting groups in any project enterprise create, manage, and store their documents, using proprietary methods and systems. This has proven to be an expensive exercise for all concerned. The problem is that cost is usually high for retaining massive amounts of paper-based documents, which have to be scanned and classified by claims analysts well after the project has ended. Locating those documents, which are usually not cross linked to project information, for claim preparation or for proving causes of an impact to the performance is a result of not having a DMIS (Document Management Information System) in the first place to capture “all” documents. To solve such problems in search and retrieval of documents, this thesis has presented a Web-based solution, entitled the Construction Project Document Information Center (CPDICenter), is developed in this research, which allows project groups the opportunity to share a uniform information model and a communications architecture for exchanging and storing documents and documents’ information. Internet standards are being established and in the future that is

expected to minimize project communication costs because users are not tied to the conventional server-client system architecture. Internet-based software utilities offer users a less steep learning curve than highly integrated proprietary or commercial software. Storage of documents' information is made with a central repository entitled DMID (Document Meta Information Database).

Moreover, this research focuses on the problem most claim analysts face, which is finding, collecting, and summarizing relevant construction documents necessary to analyze and support disputes. Indeed, we find a sizable volume of projects' knowledge and history residing in documents of all types, such as work plans, schedules, cost breakdowns, reports, laboratory tests, specifications, contract agreements, minutes of meetings, progress reports, non-conformance reports, rollover schedules, and resource utilization logs. Any information about those documents, the context of their issuance, their contents and the events accompanying their issuance, does facilitate their retrieval.

Anyone preparing a claim must include, within the scope of preparation, contemporaneous documentation collected from as many project groups as possible, even if those groups do not appear to be involved in the dispute. Project groups can include contractors, suppliers, consultants, and owners. This means that to complete the picture of the project history, all groups must supply documentation. The consistency, or the lack of it between documents—collected from all groups—may as well provide valuable evidence and guidance for estimating damages and finding causes.

The ideal document information system for the project enterprise should be a single point of access to virtual document data stores. Otherwise, project members or claim analysts run the risk of missing or overlooking important documents and losing instrumental data that could determine the fate of a claim case. It has been shown in this thesis how keeping track of documents' information within a large project organization is a complex task. Each department or project process generates collections of documents that are unique in their structure and content.

7.1.1 – Construction Documentation

Present documentation practices in construction projects complicate search and retrieval tasks because documents are never in one place, and many documents are issued but never retained or are lost, or outdated. In part, the absence of any EDMS further propagates the problem. Moreover, documents in the most part, are paper-based, even when original drafts were created with computers. Paper-based documents are hard to track, as some groups could have misplaced, misfiled, lost, or not have the latest versions of those documents. To ascertain which documents every project group has is a cumbersome and costly process, and there is also the fact that each group views documents from its own perspective in light of its role(s) in the construction operation. Different views of the construction process lead to diverse documentation standards, and incompatible document classifications and filing structures amongst project groups.

7.1.2 – Constraints Facing Project Document Control

Documents, as a medium for transferring information and knowledge amongst project groups, are exposed to the same informational constraints as any other data forms.

For example some of those problems include:

- Project groups use different software that produces incompatible document formats not interpretable amongst these applications.
- Project communications and document workflows are not formalized, and usually a project network is generated as an after thought when most site activities are well underway.
- Most projects lack a communications framework to manage and streamline correspondence, and if one exists, it is never inclusive of all groups.
- Documents are stored in digital and paper forms, according to groups' individual filing classification and storage methods. Many documents get lost or are unaccounted for, and it's a tedious and time-consuming task to locate every document. Partly this is because documents are not stored in one central place.
- Since many of those documents are digital formats that are non-generic, it is hard to scan them without using the original software used to make them. Scanning electronic and creating searchable images is not enough to automate future document content management over the web.
- In many instance projects start while groups have not concurred on:
 - Standard document forms
 - Standard document workflows as-per claims types
 - Cost codes, WBS codes, and other control structures.

The objectives of this research center around the premise that documents, in the most part, are generated with computers, hence, electronically based. As such, those documents can be stored online and served on demand to whoever has the proper access rights without the need to visit every office and site in the project to copy documents, and haul them back. Hence, some requirements are derived, and they are: 1) all documents should be classified and stored, and 2) All documents should be online—once published—and made accessible via the CPDIDCenter’s website search engine and search indexes. This motivated the design of the web-based CPDIDCenter framework, to serve as a document information center with an online dynamic repository (continuously updated) accessible by project groups, as stated by their access rights. Information collected to classify the documents and design the DMID spawn documents’ contents, project operational context as well as users’ input while registering their documents with the center. The CPDIDCenter intends to offer three major services:

- A Persistent central storage of project documents
- An Online web-based Search and retrieval
- A web-based Document Registration/Submission

7.1.3 – CPDIDCenter Paradigm: Benefits & Advantages

The CPDIDCenter has a symmetrical structure with modular components, and this is based on two principles: 1) the economy of expression, and 2) component reusability. Economy of expression means that objects (e.g. database, workflow models, search engines), which are distributed around the project, are grouped into clusters or packages

with modular information structures. The same subjects, but organized differently, will turn into new clusters, and serve different purposes. The CPDIDCenter offers numerous advantages; here is a list of expected benefits:

- Reusability of information objects, which means that the same information structure, and the same program codes, can be used again for other projects, with minimum modifications.
- Construction operators and site echelons are dispersed, and the web-based atomic framework structure of the CPDIDCenter allows access to any document regardless where the user is.
- Central definition and modification of information for all groups.
- Networking costs are reduced because groups can share or contribute to the overall costs based on their contract value and level of usage.
- All sides are going to be at the same plain field in terms of access to project data, and document sharing.
- Webfolders directory structure is uniform across the project. A CPDIDCenter administrator can change it easily.
- Documents, even when distributed to multitudes of recipients, are only added to the issuer's Webfolders (master and local). Distribution and document workflow is considered Meta data stored with the DMID. This saves space and memory.

Moreover, the persistence and stability of central data structures (DMID, business rules, Roles, Document Classes, Process Information...etc.) offers more enduring relations between project subjects and objects. That means that non-fundamental changes can be accommodated easily. As an example: adding groups, defining new documents, addition of new work packages, changing cost accounts, and adding new document

categories or titles, all these should not affect the CPDIDCenter framework and its information structures.

7.2 – Contributions: CPDIDCenter Paradigm

The main contribution is the design and configuration of a web-based DIS (Document Information System) suitable or compatible with construction management functions and document control needs especially for claims preparation. The system developed (CPDIDCenter) is project specific and shall result in the effective management of contracts in CM and includes:

- 1) The design and implementation of a relational document information database, entitled the DMID, to support the search, sorting, and retrieval of all construction documents from all groups
- 2) The implementation of the DMID in a web-based application to facilitate testing and validation of the various functions intended, and to promote a new way of communicating amongst project groups.
- 3) The analysis, and modeling and design of the information framework to streamline all the above components in a center entitled the CPDIDCenter (Construction Project Document Information Center) that works as a clearinghouse or hub of all documents in the project

The design and configuration of this DIS has resulted in the CPDIDCenter, which presents a unified Project Information Architecture to control and store all project documents. It is based on a new paradigm developed in this research and makes it

essential for all project groups to be part of the same document exchange framework, and to enlist or register all their documents with a central project web-based repository. The new information architecture is entitled the Construction Project Document Information Center (CPDICenter). This framework operates as a document-clearing house for all project groups. The CPDICenter website services include document search and retrieval, document storage, and general project information. The project organization can be a mix of a hierarchy and a network structure, and the CPDICenter framework of communications and information models adapts to any project organization because document processing is handled in light of the contractual relations vis-à-vis the roles each person in the project plays. The CPDICenter establishes also the document storage structure, and document information models. It is proposed as a web-based development to bypasses system incompatibilities found in current document control systems. The components of the CPDICenter include:

- A framework for communications, with detailed web architecture and system workflow models.
- A Document Meta Information Database (DMID) with three integrated Components:
 - The Project process control information.
 - Contract requirements and Workpackages.
 - Document Versioning, Workflow & Virtual Webfolders
- A prototype website to test the interaction with the DMID contents and test data retrieval and document registration.

- A uniform project-wide Webfolder design to house documents. In the new system, each group owns two Webfolders (master and local). The design is supported by a document Classification, and categorization scheme.

Each document is cross-linked to key information subjects from the project, and to other documents as well. This enhances the chances of retrieving documents because the user can trace or locate a document by associating it with contextual information about: 1) project processes and events, 2) claim issues and changes 3) contract commitments, and 4) decision rationales.

Project groups and claims analysts need to understand the project history from documents and people. Hence, The proposed system (CPDICenter) facilitates the job of project managers and contract administrators and claim analysts when trying to prepare claim cases by saving search and retrieval times and ensuring the finding of documents. It, for the first time, offers a framework for a Document Information Management System (DMIS) that cross-references each document to project operations, events, and processes. There is a need to classify document information, and design a proper storage structure in a system that binds all groups and captures all their documents, which the CPDICenter satisfies.

Since projects' deliveries do not happen without changes or alterations of some sort there is a need for a better document control, which enables groups to access (Via a portal) all project documents, and this is solved by the CPDICenter system, and gives confidence to the claims group that all documents are registered and nothing is lost.

7.3 – Work Limitations

The considerations and limitations incorporated in this research are:

- Documents will have to be electronic to traverse the CPDIDCenter framework. Electronic-based (i.e. digital) documents are created by software tools.
- Users of the system will have to access the Internet to interact with the future CPDIDCenter, which assumes a minimum level of capability in terms of hardware (servers) and software (browsers; database) by project groups.
- Even though contractors produce most of the documentation, the cost of the system can either be shared or paid for by the major groups like the owner or the general contractor. Another option may be to let contractors account for the CPDIDCenter cost in their bids.
- Documents, once issued, are never changed or altered. Changes constitute new documents with new identification version numbers.
- The treatment of document information and project modeling caters to the construction industry with emphasis on claims information classification. Nevertheless, this is not restrictive to efforts aimed at re-adapting the system to other industry sectors. With minor changes, the information models pertaining to role definitions, business rules, control structures, document information, and DMID's table relationships shall persist.

7.4 – Recommendations for Future Research

Project Document Content Management

Many documents are routine; take for example daily progress or site reports, weekly reports, and resource utilization charts. The contents of those reports are drawn from different data sources, sites and operations across the project organization, and this

poses two problems: 1) usually an extended time is lost preparing those documents, and the accuracy of the data is usually affected by the many layers of treatment and conversions. Currently the web technology is available to enable an automated content control and customization according to user's needs. This is evident in personalized web portals that bring special information to their users. Internet protocols and standards help promote more interoperability and access to information. XML (eXtended Markup Language) is one of those standards, which makes it possible for the content of an XML version of a document to be inserted into a database seamlessly or to insert meaningful content like names, dates, sites, resource codes...etc. into the document itself. For example, in the aecXML initiative, parse (able) XML (eXtended Mark-up Language) tags within a document have to be inserted. In such an event, the CPDICenter has to have all possible XML Schemas before hand. XML inserts Meta tags around blocks of data contained in a document in order to explain to the server what they should mean and eventually link the document to any particular topic. This assures more meaningful front-end search functionality and knowledge mining capabilities over many web-based information repositories and sites. The user gets to define lists of industry-specific semantics, and project-specific hierarchies of subjects and knowledge areas to search documents against. Automation carries a little overhead in terms of coding or programming, because the created classes and objects are going to be reused times and over again. What is needed is to identify the information sources, then customize the information content (view) of each document in order to get the needed information to the recipients. Content management could save valuable time and reduces redundancy in data. Every project group can customize the contents and delivery times.

Project Knowledge Base for Knowledge Mining

It is possible to develop a knowledge base from the huge resource of documents collected throughout the life of the project. An expert system or AI application (using forward or backward chaining/propagation) can be used to test documents against a set of facts, and rules to arrive at conclusions. The AI or Expert systems can be updated with new rules to improve results. Artificial Intelligence (AI), which categorizes documents by example or by case-based-reasoning, facilitates search for documents. However, these techniques often lead to unpredictable, erroneous, and superficial results. Possible solution is establishing flexible construction taxonomies by using linguistic technology to find key concepts in a document. Nevertheless, Taxonomy needs updating frequently as information needs and idiom connotations evolve.

Automatic Profiling and Classification of Documents

Automatic classification would be a natural progression of the CPDIDCenter Information Architecture, which includes documents' and claims' Information classification, construction subjects, communication framework, domain specific taxonomies and keywords, document meta database, and the website structure. It is feasible to configure the CPDIDCenter to automatically monitor document issuance from all groups and to automatically classify them within its document information architecture. Automatic indexing of documents' information is possible through the application of rules-based engines that allow users to set up indexing rules and construction taxonomies using Artificial Intelligence or Case-Based-Reasoning linguistic scanners.



Chapter Eight *References*

- Abou-Zeid, Azza M. K. "Data Flow Identification to support Project Automation/Integration and Productivity", August 3rd, 1993. A Dissertation Submitted to the Graduate School of the University of Wisconsin-Madison for the degree of Ph.D.
- ADO 2.1 (2000) "ADO Programmer's Reference" Wrox Press, USA
- aecXML Initiative. [Online: April 2000], "aecXML-A Framework for Electronic Communications for the AEC Industries". Available: <http://www.aecxml.org>.
- Alkass, S., Mazerolle, M. and Harris, F., "Construction Delay Analysis Techniques" *Construction Management and Economics* (1996) 14, pp. 375-394, E & FN Spon.
- Alkass, S., Mazerolle, M., Tribaldos, E. and Harris, F., "Computer Aided Construction Delay Analysis And Claims Preparation", *Construction Management and Economics* (1995) 13, pp. 335-352, E & FN Spon.
- Amberg, Michael. "Enhancing The Competitiveness of Enterprises by Applying Advanced Workflow Management Systems". Euroconference: European Management in Face of Knowledge Driven Competition, Porto, Portugal, 19th-21st September 1996.
- American Arbitration Association AAA. [Online: October 23, 98], "*Alternative Dispute Resolution: Arbitration, Mediation, Ethics, for Construction and Commercial Arbitration*". Available at :<http://www.aaa.org>.
- Archer, George O., Futcher, Keith, and McMahon, Michael A. "Multi-Participation Project Information Management System". *CIB Proceedings W78-TG10, IT Support*

- for Construction Process Reengineering, Cairns-Australia. Publication 208, 9th-11th July 97. Pp.41-52.*
- Arditi, David., and Robinson, Mark A. "Concurrent Delays in Construction Litigation". *Cost Engineering, AACE*. Vol. 37/No. 7, July 1995.
- Batini, C., Ceri, S., & Navathe, S. (1992), "*Conceptual Database Design: An Entity-Relationship Approach*". The Benjamin/Cummings Publishing Company Inc. CA., USA.
- BCCM, ISO TC184/SC4/WG3 "Building Construction Core Model, Project Proposal". Proposed ISO-STEP 10303 part 106. Document N341, October 1994.
- Beaumont, R. "Overview of Contracts: A Comparative Analysis". Seminar at Construct Canada Exhibition/Conference, Toronto, Ontario., December 4, 1997.
- Bernard, Ryan (1998). "The Corporate Intranet", Second Edition from John Wiley & Sons, NY.
- Bjoerk, Bo-Christer, "Conceptual Models of Product, Project and Document Data; Essential Ingredients of CIC", *first Congress on Computing in Civil Engineering. ASCE*, June 1994.
- Booch, G., Rumbaugh, J., & Jacobson, I. (1998), "The Unified Modeling Language User Guide". Addison Wesley Longman Inc. USA.
- Boughton, G., Fatcher, K., Torbet, E. "Project-Information-Management-Systems Deployed in Anticipation of Disputes on Multi-Contract, Non-Traditional Infrastructure Procurement". CIB Proceedings W78-TG10, IT Support for Construction Process Reengineering, Cairns-Australia. Publication 208, 9th-11th July 97. Pp.77-88.
- Brown, A., Rezgui, Y., Cooper, G., Yip, J., and Brandon, P. [Online: January 1998], "Promoting Computer Integrated Construction Through the Use of Distribution Technology". CIB Electronic Journal. Available: <http://itcon.org>. Published October 1996.

- Brunies, Regula A. "Impact Costs-What Are They? And How to Quantify them". PMI Symposium, San Francisco, California-September 17-21, 1988, pp. 386-393.
- Bubbers, G., & Christian, J. (1992). "Hypertext and Claim Analysis", *ASCE Journal of Construction Engineering and Management*, Vol. 118, No. 4 December.
- CCDC-40, (1994) " Rules for Mediation and Arbitration of Construction Disputes". *Canadian Construction Document Committee*.
- Chan, D. W. and Kumaraswamy, M. M., "A Comparative Study Of Causes Of Time Overruns In Hong Kong Construction Projects", *International Journal of Project Management*, Vol. 15, No. 1, pp.55-63, 1997, Elsevier Science, Ltd. and IPMA U.K.
- Chen, Peter. 1977 "*The Entity-Relationship Approach to Logical Data Base Design*" Wellesley, MA:QED Information Sciences, Inc.
- Conklin, E. Jeffrey. "Designing Organizational Memory: Preserving Intellectual Assets in a Knowledge Economy". *Group Decision Support Systems GDSS*, Washington DC. <http://www.gdss.com/DOM.htm>. December 28, 1999.
- Conlin, J. and Retik, A., "The Applicability of Project management software and advanced IT techniques in construction delays mitigation", *International Journal of Project Management*, Vol. 15, No. 2, pp. 107-120, 1997, Elsevier Science Ltd. and IPMA UK.
- Corning, M., Elfanbaum, S., & Melnick (1997). "*Working with Active Server Pages*". 1st ed., QUE Corporation, IN, USA
- Cox, Robert K. "Managing Change Orders and Claims". *ASCE Journal of Management in Engineering*. January/February 1997.
- Dado, Edwin, and Tolman, Frits. "Support of Site Construction Processes by Product Data Technology". CIB Proceedings W78-TG10, The Life-Cycle of Construction IT Innovations: Technology Transfer from Research to Practice, Stockholm-Sweden. June 3rd-5th 1998. Pp.151-161.

- De Leon, Gui Ponce, and Knoke, John R., "Probabilistic Analysis of Claims for Extensions in the Contract Time". *Second Congress on the Computing In Civil Engineering, ASCE* 1995. Pp. 1513-1520.
- Diekmann, James E., and Kim, Moonja P. "SUPERCHANGE: Expert System For Analysis of Changes Claims". *Journal of Construction Engineering and Management, ASCE*, Vol. 118, No. 2, June, 1992. Pp. 399-411.
- Edwards, D. J., Shaw, T., Holt, G. D. "Electronic Document Management Systems and The Management of UK Construction Projects". *Building Research and Information* Chapman & Hall inc. UK. Vol. 24, Number 5, 1996
- Elmasri, Ramez, & Navathe, Shamkant B. (2nd edition, 1994), "Fundamentals of Database System". The Benjamin/Cummings Publishing Company Inc. CA., USA.
- Elnagar, H. and Yates, J., "Construction Documentation Used as Indicators of Delays", *Cost Engineering* Vol. 39/No. 8 August 1997, AACE.
- ENR Engineering News Record feature Article. "On The Issue of Contractors' Financial Health" ENR McGraw Hill Inc. USA, December 2nd, 1991.
- Eriksson, Hans-Erik, and Penker, Magnus. (1998), "UML ToolKit". John Wiley & Sons , USA.
- Feldman, Susan (2000) (White Paper), "Northern Light: A new Model for the Enterprise Information Portal". Available March 2001 at www.idc.com.
- FIDIC, [Online August 97] "Conditions of Contract for Works of Civil Engineering Construction", fourth edition, Lausanne, Switzerland. Published 1987, available at: <http://www.iccwho.org/commissions/arbitration>.
- Findley, D. A., "Construction Claims Preparation under ADR", 1997 AACE International Transactions, Dallas, TX, pp. C&C.01.2-4.
- Froese, T., Yu, K., and Shahid, S. "Project Modelling in Construction Applications". *Computing in Civil Engineering: Proceedings of the Third Congress, ASCE, Anaheim, Calif.* June 1996, pp. 572-578.

- Froese, Thomas. "Core Process Models and Application Areas in Construction".
Modelling of Buildings Through Their Life Cycle: International Workshop,
Organized By: CIB W78-TG10, Stanford University, August 21st-23rd 1995.
- Gross, Mitchell. "Bridging the Back-Office/Front-Office Gap". *Best Practices in Enterprise Content Management KMWorld* May 2001.
- Hammad, Mamoon, and Alkass, Sabah (1999-a) "Documenting for Claims: Information Technology IT issues and Requirements". *CSCE 27th Annual Conference*, Saskatchewan-Canada, 2-5 June 1999.
- Hammad, Mamoon, and Alkass, Sabah (1999-b). "Requirements for the Active Reconstruction of Impact Claims' Documentation". *The Seventh International conference on Civil and Structural Engineering Computing* Oxford, England 13-15 September 1999
- Hammad, Mamoon, and Alkass, Sabah (2000-a), "Formalizing Project Document Creation & Management in Support of Impact Claims Analysis". *PMI AGC 7th Annual Conference*, Bahrain. February 2000.
- Hammad, Mamoon, and Alkass, Sabah (2000-b). "A Web-based Construction Project Document Information Center In Support of Claims Analysis". *ICCCBE-VII Proceedings, ASCE* Stanford, CA, USA, August 2000.
- Hammad, Mamoon, and Alkass, Sabah (2000-c). "Web-Based Construction Project Document Information Center To Support Performance Impact Analyses". *ISARC 17 Proceedings, Robotics and Automation in Construction*. Taiwan University, Taiwan 18-20 September 2000.
- Hammad, Mamoon, and Alkass, Sabah (2001-a) "CPDICenter: Web-based Unified Access to Project Contemporaneous Documents". *AACE International's 45th Annual Meeting*, Pittsburgh, PA, June 17th-20th 2001.
- Hammad, Mamoon, and Alkass, Sabah (2001-b). "Architecture of a Web Based Document Inforamtion Center". *1st International conference on innovation in Archeticture and construction. CICE International* Loughborough University, UK. 18-20th July 2001.

- Hanrahan, Robert P. [Online march 98] "The IDEF Process Modelling Methodology". Knowledge Based Systems Co. Available at <http://www.ideal.com>.
- Hardwick M., Spooner, D.L., Rando, T., and Morris, K.C. "Data Protocols for the Industrial Virtual Enterprise" 1997.
- Harmon, Kathleen M. J., and Stephan, Bruce M. "claims Avoidance Techniques: Best Practices for Contract Administration". *International Transactions of the AACE 45th Annual meeting*, CDR.01.1. June 2001, Pittsburgh, Pennsylvania.
- Hay, David, and Healy, K. Anderson. [Online: May 98]. "Defining Business Rules -- What are they really?" GUIDE International Corporation, last updated November 30, 1997. Available at <http://www.essentialstrategies.com>
- Ibbs, C. W., "Quantitative Impacts Of Project Change: Size Issues", *Journal of Construction Engineering and Management, ASCE*. Vol. 123, No. 3, September 1997.
- IDEF0: Federal Information Processing Standards Publication (FIPS PUBS) Draft 183, "Announcing the Standard for integration definition for function modeling (idef0)". 1993 December 21. <http://www.qd.cl/WEBPAGES/IDEF/IDEF0/idef0.html>
- ISO Technical Report TC59/SC13. (April 1993), "*Classification of Information in the Construction Industry*", Building Construction: Organization of Information in the Processes of Design, Manufacture and Construction, Norway.
- James, Martin. 1987 "*Recommended Diagramming Standards for Analysts and Programmers*". Englewood Cliffs, New Jersey, Prentice Hall
- Jennings, Roger. (1997), "*Using Microsoft Access 97-Special Edition*". QUE Corporation, IN, USA.
- Jensen, D. Jr., Murphy, J. D. Jr. and Craig, J., "The Seven Legal Elements Necessary for a Successful Claim for a Constructive Acceleration", *Project management Journal, PMI*, March 1997, Vol. 28, No. 1, 32-44.

- Jergeas G. F. and Hartman, F. T., "Contractors' construction-Claims Avoidance", *Journal of Construction Engineering and Management, ASCE* Vol. 120, No. 3, September 1994,.
- Kaming, P. F., Olomolaiye, P. O., Holt, G. D., and Harris, F. C. "Factors Influencing Construction Time and Cost Overruns on High-Rise Projects in Indonesia". *Construction Management and Economics, E & FN Spon, UK.* 1997 15, pp. 83-94.
- Kangari, Roozbeh. "Construction Documentation in Arbitration". *Journal of construction Engineering and Management ASCE*, Vol. 121, No. 2, June 1995. USA
- Kappes, S., Schmidt, W. J., and Sears, D. D. [Online: December 1997], "Document Management for The Knowledge Worker System". USA Construction Engineering Research Laboratory (USACERL), ADP Report 95/38. Available: <http://www.cecer.army.mil/kws/dmstoc.htm>. Published September 1995.
- Kerzner, Harold. (1998), "*Project Management: a Systems Approach to Planning, Scheduling, & Controlling*", 4th edition. Pp 897-915. Van Nostrand Reinhold, NY, NY.
- Kroenke, David M. (1992), "*Management Information Systems*", (second edition), Mitchell McGraw-Hill Inc., USA. T58.6 K77 1992.
- Laudon, Kenneth C., & Laudon, Jane P. (2nd edition 1997), "*Essentials of Management Information Systems: Organization and Technology*". Prentice Hall, New Jersey, USA.
- Leonard, Charles A. "*The Effect of Change Orders on Productivity*". A Thesis Presented to Building Engineering-Concordia University, Mtl, Que., Canada. 1987
- Mazerolle M. and Alkass S., "An Integrated System to Facilitate the Analysis of Construction Claims", *5th international conference Computing in Civil Engineering, ASCE*, 1993 pp.1509-1516.
- Mazerolle, Mark " *Cost Effective approach for delay analysis and claims preparation*" November 1992. A major technical report submitted to the Center for Building Studies, Concordia University, Montreal, Canada.

Moselhi, Osama. (1993) "BLDG 781: Construction Acquisition and Control Lecture Notes". , *Building, Civil & Environmental Engineering*, Concordia University, Canada.

NASA (a). [Online: May 1998], "Document and Data Control". Marshall Space Flight Centre MSFC Centerwide Work Instruction MSFC-P05.1 Revision F. Available: <http://masterlist.msfc.nasa.gov/>. Published October June 1997.

NASA (b). [Online: May, 1998], "MSFC Documentation Repository Input/Output and Data Management Project Requests, MSFC-P05.1-C06". Marshall Space Flight Centre: MSFC Centerwide Work Instruction. Available: <http://masterlist.msfc.nasa.gov/>. Published October 1998.

Ndekugri, Issaka E., McCaffer, Ronald. "Management Information Flow in Construction Companies". *Construction Management and Economics*, 1988, 6, 273-294. E & F.N. Spon UK.

Nee, Paul A. (1996), "ISO 9000 in Construction", John Wiley & Sons, Inc., USA.

Ott, Jur. Eduard. "*CIB Proceedings W78-TG10*, The Life-Cycle of Construction IT Innovations: Technology Transfer From Research to Practice, Stockholm-Sweden. June 3rd-5th 98. Pp.335-345.

PMI (1996). "*PMBOK Guide: A Guide To The Project Management Body of Knowledge*". PMI Communications, PA. USA.

Powell-Smith, V., and Sims, J. (1985) "*Contract Documentation for contractors*". William Collins Sons & Co., London, England.

Pruitt, Bruce W. "The Value of the System Engineering Function in Configuration Control of a Major Technology Project". *PMI Journal*, Vol30, No. 3. Pp. 30-36, September 1999.

Revay Report. "Can Construction Disputes Be Avoided?" Revay & Associates Limited RAL Vol. 14 No. 2, June 1995. Montreal, Quebec, Canada.

- Revay Report. "Delay Analysis—Using the "Snapshot" Technique New Unit to Serve Sureties". Revay & Associates Limited RAL, Vol. 7 No. 1 May 1988, Montreal, Quebec, Canada
- Revay Report. " Construction Claims: Role of Owner, and Contractor". Revay & Associates Limited RAL A Seminar held in Montreal, Quebec, in 1987.
- Rezgui Y., Zarli A., Bourdeau M. and Cooper G. "Inter-enterprise Information management in Dynamic Virtual Environments: the OSMOS approach", *Proceedings of Construction Information Technology 2000 (CIT2000)*, 28-30 June 2000, Reykjavik (Iceland), pp. 731-741.
- Rezgui, Y. and Debras, P. "An Integrated Approach for a Model Based Document Production and Management", *Electronic Journal, CIB W78 Workshop*. Available at: <http://itcon.org/>. Published November 1995
- Rezgui, Y., and Cooper, G. "A Proposed Open Infrastructure for Construction Project Document Sharing". Available: <http://itcon.org> *CIB Electronic Journal*. Published December 1998
- Rezgui, Y., Cooper, G., Marir, F., Vakola, M., and Tracey, A. "Advanced Document Management Solutions for The Construction Industry: The CONDOR Approach". *CIB Proceedings W78-TG10, The Life-Cycle of Construction IT Innovations: Technology Transfer From Research to Practice, Stockholm-Sweden*. June 3rd-5th 1998. Pp.373-383
- Rumbaugh, J., Blaha, M., Premerlani, W., Eddy, F., and Lorensen, W. (1991), "*Object - Oriented Modelling and Design*". Prentice-Hall, New Jersey, USA.
- Russell, Alan, and Froese, Thomas. [Online: March 22nd, 1998], "Challenges and a Vision for Computer-Integrated Management Systems for Medium-Sized Contractors". Available: <http://www.civil.ubc.ca/~tfroese/>. Also, Published in *Canadian Journal of Civil Engineering, CSCE*, Vol. 24, No. 2, April 1997, pp. 180-190.
- Schroedel, Ralph B. "Documenting Defensively", *Journal of Management in Engineering, ASCE*. November/December 1997. Pp. 22-25.

- Scott, S., "Delay Claims In U.K. Contracts", *Journal of Construction Engineering and Management ASCE*, Vol. 123, No. 3, September 1997..
- Semple, C., Hartman, F. T., Jergeas, G. "Construction Claims and Disputes: Causes and Cost/Time Overruns". *Journal of Construction Engineering and Management, ASCE*. Vol. 120, No. 4, December 1994. Pp. 785-795.
- Short, Donald E. "Making Effective Use of ADR Provisions In Design/Build Contracts", Seminar at Construct Canada Exhibition/Conference, Toronto, Ontario. December 1997.
- Shum, Simon Buckingham. "Negotiating the Construction and Reconstruction of Organizational Memories".
http://www.iicm.edu/jucs_3_8/negotiating_the_construction_and/paper.html.
 August 21st, 1998.
- Tardif, Lorna. "*Procurement: Communicate-or Else...*" A seminar presented at the International Symposium of CIB-Commission W92. Universite de Montreal 20-23 May 1997.
- The Committee on Construction Management (TCCM). "Qualification and Selection of Construction Managers with Suggested Guidelines For Selection Process", *Journal of Construction Engineering and Management, ASCE*. Vol. 113, No. 1, March 1987, pp. 51-89.
- Thomas, H. Randolph, and Napolitan, Carmen L. "Quantitative Effects of Construction Changes on Labour Productivity". *Journal of Construction Engineering and Management, ASCE*, Vol. 121, No.3, September 1995. Pp. 290-296.
- ToCEE (Ep20.587) "Towards Concurrent Engineering Environment in the Building and Engineering Structures Industry. Product and document modelling, information logistics, and legal issues". <http://www.cib.bau.tu-dresden.de/tocee/>. 1999.
- Torone, Brian, and Kreitzberg, O'Brien. "ADR Battles and How They Are Won". *Project Management Institute 27th Annual Seminar/Symposium, PMI*, Boston, Mass. October 7th-9th, 1996. Pp. 92-94.

- Vanegas, Jorge A., Halpin, Daniel W. "Use of Construction Simulation in Claims Analysis". *Computing In Civil & Building Engineering, CSCE, 5th International Conference*, 1993, Vol. 2, pp. 1207-1214.
- Vicerich, Barbara "Trial Preparation". *Wagner-Hohns-Inglis Inc. Comments on Construction Industry Newsletter*. Winter 1992.
- Vidogah, William, and Ndekugri, Issaka. "Improving Management of Claims: Contractors' Perspective". *Journal of Management in Engineering, ASCE*. Vol. 13, No. 5, September/October, 1997.
- Vidogah, William, and Ndekugri, Issaka. "Improving the Management of Claims on Construction Contracts: Consultant's Perspective". *Construction Management and Economics*, E & FN Spon, UK. 1998 (16). Pp. 363-372.
- Weiser, M. and Morrison, J. "Project Memory: Information Management for Project Teams", *Journal of Management Information Systems*, M.E. Sharpe, Inc. Spring 1998, Vol. 14, No. 4, pp. 149-166.
- Yogeswaran, K., Kumaraswamy, M. M., and Miller, D. R. A. "Claims for Extensions of Time in Civil Engineering Projects". *Construction Management and Economics*. 1998-16, 283-293. E & FN Spon, UK.
- Zack Jr., James C. "Practical Dispute Management". *Cost Engineering, AACE*, Vol. 37/No.12, December 1995.
- Zarli A. and Richaud O. "Requirements And Technology Integration For IT-Based Business-Oriented Frameworks In Building and Construction". *CIB Information Technology in Construction*. Rotterdam, Netherlands, December 1999.



Appendix A CPDCenter Document Types, Classes and Sample Contract Clauses

A.1 – Common Titles of Pre-Construction Documents:

<ol style="list-style-type: none">1. Instructions to Bidders2. Preliminary Construction Schedule3. Preliminary Stage/Phase Schedule4. Geotechnical Data5. Existing Conditions Report6. Bid Forms7. Labour Bond8. Material Bond9. Performance Bond10. Bid Security11. Subcontractors Forms12. Suppliers List13. Bid Breakdown and cost14. Sub Contractor or Trade Bids15. Non-Collusion Affidavit16. Agreement Forms17. Certificates18. Insurance19. Codes of Practice20. Standards21. Contract General Conditions22. Additional Conditions23. Specifications24. Special Specifications25. Contractor Proposed Alternatives26. Initial Drawings27. Milestone Schedules28. Addenda and Modification29. Proposed WBS30. PSWBS31. Contract Package31. Soil tests by the owner or his consultant.32. Bid invitations to contractors.33. Addenda.34. Contractors bidding documents35. Contractor cost breakdowns.	<ol style="list-style-type: none">36. Tentative plans and methods.37. Contract documents, which include:38. Invitations to sign.39. Agreements.40. Payment to mobilize.41. Specifications.42. General conditions.43. Drawings.44. Milestones schedules.45. Licenses and permits.46. Bonds, surety, and insurance.47. Supplier's commitments.48. Subcontractor's commitments.49. Union agreements.50. As-Built reports.51. As-Planned Schedules and S-Curves.52. Bond and insurance documents.53. Change interpretation notices.54. Change orders.55. Drawing Revisions and Updates Logs.56. Letters of Intention.57. Mobilization Plans.58. Field transmittal Memos.59. Fieldwork orders.60. Forman daily records.61. Incident reports.62. Internal memorandums.63. Laboratory results.64. Labour Union and trades orders.65. Man-hour and Equipment Logs.66. Testing Procedures and Methods.67. Toolbox safety meetings.68. Site operation Videos.
--	---

A.2 – Document Titles for the Construction Operation

1. As-Built Drawing	31. Minutes of meetings
2. As-done Schedule.	32. Non Conformance Report NCR
3. As-Planned Schedule edition.	33. Payment request
4. PCWBS	34. Permits
5. CBS Diagram	35. Phone Calls
6. RBS Diagram	36. Phone logs
7. WBS Diagram	37. Pictures, Snap Shots, Still Pictures, Surveillance.
8. BOQ, Bill of Quantities	38. Procurement Report
9. Change interpretation notice	39. Productivity Analysis Report
10. Change order	40. Quality evaluation Reports
11. Close-out Check List	41. Rental Cost summary
12. Work Instruction	42. Request for Information
13. Drawing Revision	43. Request for proposal
14. Drawing Log	44. S-Curve tracking, trending, and forecasting. Progress report.
15. Drawings and Design changes.	45. Shipping and packing Slips
16. Earned value s-curves.	46. Site investigation reports, and site visits.
17. Employee and tradesmen certificates	47. Site memorandums from site operatives.
18. Exception or Non-Conformance Report	48. Site query form
19. External memos from suppliers or affiliates, or lawyers...etc.	49. Soil reports.
20. Field transmittal Memos	50. Specification change notice.
21. Fieldwork order.	51. Supplier Catalogues,
22. Forman daily records	52. Specifications sheets,
23. Incident report	53. Testing Procedures and Methods
24. Internal memorandums	54. Testing standards
25. Inventory Reports	55. Time Sheets
26. Laboratory results.	56. Tool box safety meetings
27. Labour Union and trades orders	57. Variance Analysis Report
28. Man-hour and Equipment Logs	58. Videos
29. Man-hour overtime log-sheets.	59. Weather Log
30. Meetings at site	

A.3 – CPDICenter Document Classes

A.3.1 – Class Proprietary Proprietary documents are not necessarily exchanged according to contract requirements. A category may be replicated and its class type changed later.	
1) Bidding <ul style="list-style-type: none"> a. Analysis b. Itemized Bid c. Pre-bid Soil Investigation 2) Cost/Accounting Records <ul style="list-style-type: none"> a. RBS (Sub Classified According to Resource Breakdown Structure) 3) Lab Results 4) Internal Inspections Reports 5) Special Methods & Techniques 6) Field Reports <ul style="list-style-type: none"> a. Orders & Directives b. Job Diaries c. Photographs d. Videos 7) Budget 8) Quantity Take Offs 9) Internal Transmittals 10) Memos/Memoranda 11) Field/Jobsite Logs 12) Work Descriptions 13) Payroll records 14) Site Reports 15) Equipment <ul style="list-style-type: none"> a. Utilization Sheets b. Reports of Maintenance & Operation c. Failures d. Expenses/Payments 16) Over Head <ul style="list-style-type: none"> a. Office Expenses b. Site OH c. Extended OH 	17) Procurement <ul style="list-style-type: none"> a. Orders b. Material Deliveries c. Invoices d. Payments to Suppliers 18) Financial Statements 19) Safety <ul style="list-style-type: none"> a. Incidents Reports b. Snags c. Rules & Regulations 20) Delay Reports 21) Program Schedules <ul style="list-style-type: none"> a. Planned Weekly Outlooks b. As-Built Gant Charts c. Deliverables (documentary) d. Procurement Schedules 22) Expert Reports 23) Drawings & Plans <ul style="list-style-type: none"> a. Shop Drawings b. Product Diagrams and Models 24) Site Visits 25) Status Reports <ul style="list-style-type: none"> a. Work Progress (WBS coded) b. Issues c. Claims 26) Claims <ul style="list-style-type: none"> a. Lawyer preparations b. Expert reports c. Affidavits 27) Internal Quality Audits

A-3.2 Class: Public

These are documents made available during a project for all groups to view, reference, and distribute.

- | | |
|--|---|
| <ul style="list-style-type: none">1) Permits2) Certificates<ul style="list-style-type: none">a. Completionb. Of compliancy3) Bonds<ul style="list-style-type: none">a. Labourb. Materialc. Performance4) Bid invitations5) Addenda6) Weather logs7) Master schedules8) Legal procedures<ul style="list-style-type: none">a. Claim rulesb. Claim legal precedentsc. Claim resolutionsd. Court discovery orders9) Architectural Models | <ul style="list-style-type: none">10) Value Engineering Studies11) Feasibility12) Project News13) Liens14) Daily project reports15) Public financial statements16) Training material17) Warranties18) Licences19) Labour Union Agreements20) Close-out punch lists21) Expert reports22) Environmental assessments23) Claims precedents24) Site pictures<ul style="list-style-type: none">a. Videob. Site organization/layout plansc. Affidavits |
|--|---|

A.3.3 Class Transactions

All documents exchanged between any two project groups or more

- | | |
|--|--|
| <ol style="list-style-type: none">1. Drawings<ol style="list-style-type: none">a. Masterb. Shopc. Approved Transmittalsd. Product Modelse. Product Diagramsf. As-Built2. Bid<ol style="list-style-type: none">a. Bid Analysisb. Addendac. Itemized Bid Estimated. Bid Invitationse. Site Visitsf. Soil Studiesg. Suretyh. Bonds<ol style="list-style-type: none">i. Labourii. Materialiii. Performance3. Cost Reports4. Payment Requisitions/Invoicing5. Inspection Reports6. Changes<ol style="list-style-type: none">a. Change Directives When change is pendingb. Force Reportsc. Change Ordersd. Proposede. RFPf. RFIg. Proposals/Quotationsh. Analysis/Pricingi. Status7. Snags<ol style="list-style-type: none">a. Non Conformance Reportsb. Failuresc. Delaysd. Interruptionse. Site Access21. Overhead<ol style="list-style-type: none">a. Officeb. Sitec. Extended22. Resource Reports23. Planning24. Deliveries<ol style="list-style-type: none">a. Orders<ol style="list-style-type: none">i. Materialii. Equipmentiii. Othersb. Delivery/Shipping Slipsc. Invoices | <ol style="list-style-type: none">8. Schedules<ol style="list-style-type: none">a. Masterb. Outlooksc. Milestonesd. As-Builte. Baselinesf. CPM Analysisg. Deliverablesh. Procurementi. Resource loadedj. Deliverables Milestone9. Directives10. Submittals11. RFI12. RFP13. Quantity Take-Offs14. Conversations<ol style="list-style-type: none">a. Phoneb. Memos15. Newsgroup discussions<ol style="list-style-type: none">a. Work Descriptionsb. Method Descriptionsc. Technologyd. Building Processes16. Progress<ol style="list-style-type: none">a. Reportsb. Gant Charts17. Certificates<ol style="list-style-type: none">a. Completionsb. Of Compliancec.18. Labour<ol style="list-style-type: none">a. Agreementsb. Trade logsc. Productivity Charts19. Delays20. Weather28. Site<ol style="list-style-type: none">a. Reportsb. Layoutc. Existing Utility Maps29. Permits30. Licences31. Notices<ol style="list-style-type: none">a. Proceedb. Stopc. Start32. Contract modifications33. Expert reports34. Claims |
|--|--|

- d. Payments
- 25. Financial
 - a. Planning
 - b. Reports
- 26. Meeting
 - a. Minutes
 - b. Agenda
 - c. Resolutions
- 27. Surveying
 - a. Quantity Surveying
 - b. Topographical

- a. Statutory (Governmental)
- b. Impacts Analysis
- 35. Government Correspondence
- 36. Soil Reports
- 37. Lab Reports
- 38. Affidavits
- 39. Quality Conformance
- 40. Audits

A-7 Class Definitions

Definitions: Document Types are any documents used to guide the project processes.

- | | |
|---|--|
| <ul style="list-style-type: none">1. Contract<ul style="list-style-type: none">a. Agreementsb. Specifications<ul style="list-style-type: none">i. Special Specsc. Conditions<ul style="list-style-type: none">i. Supplemental Conditionsd. Planse. Drawings2. Standards<ul style="list-style-type: none">a. Codes<ul style="list-style-type: none">i. Practiceii. Designb. By laws3. Contract Changes4. Geotechnical Surveys5. Feasibility Studies6. Environmental Assessments7. Historical Data<ul style="list-style-type: none">a. Weatherb. Earthquakesc. Others8. Value Engineering Reports9. Government<ul style="list-style-type: none">a. Regulationsb. Inspections | <ul style="list-style-type: none">10. Existing Utility Maps11. Bonds and Surety12. Finance13. Baselines<ul style="list-style-type: none">a. Scheduleb. Designc. WBS14. Safety Procedures15. Warranties16. Scope17. O & M Manuals18. Information Control<ul style="list-style-type: none">a. WBSb. CBSc. RBSd. Work Packages19. Communication Procedures20. Project Groups & Members21. Product Catalogues22. Claims<ul style="list-style-type: none">a. Precedentsb. Resolution Procedures |
|---|--|

A.4 – Sample Contract Specification Sections and Clauses

Source: U.S. DEPARTMENT OF TRANSPORTATION Federal Highway Administration FP-96 1996
 “Standard Specifications For Construction of Roads and Bridges on Federal Highway Projects”.

<p>100. GENERAL REQUIREMENTS Section 101 TERMS, FORMAT, AND DEFINITIONS 101.01 Meaning of Terms 101.02 Specifications Format 101.03 Abbreviations 101.04 Definitions Section 102 BID, AWARD, AND EXECUTION OF CONTRACT 102.01 Acquisition Regulations 102.02 Preparation of Bids 102.03 Bid Guarantee 102.04 Individual Surety 102.05 Public Opening of Bids 102.06 Performance and Payment Bonds Section 103 SCOPE OF WORK 103.01 Intent of Contract 103.02 Disputes 103.03 Value Engineering 103.04 Contractor Records. 103.05 Partnering Section 104 CONTROL OF WORK 104.01 Authority of the Contracting Officer 104.02 Authority of Government Inspectors 104.03 Specifications and Drawings 104.04 Coordination of Contract Documents 104.05 Load Restrictions Section 105 CONTROL OF MATERIAL 105.01 Source of Supply and Quality Requirements 105.02 Local Material Sources. 105.03 Material Source Management 105.04 Storing and Handling Material 105.05 Use of Material Found in the Work Section 109 MEASUREMENT AND PAYMENT 109.01 Measurement Methods 109.02 Measurement Terms and Definitions 109.03 Weighing Procedures and Devices 109.04 Receiving Procedures 109.05 Scope of Payment 109.06 Pricing of Adjustments 109.07 Eliminated Work 109.08 Progress Payments 109.09 Final Payment</p>	<p>154 Contractor Sampling and Testing 155 Schedules for Construction Contracts 156 Public Traffic 157 Soil Erosion Control 158 Watering for Dust Control Section 106 ACCEPTANCE OF WORK. 106.01 Conformity with Contract Requirements 106.02 Visual Inspection. 106.03 Certification. 106.04 Measured or Tested Conformance 106.05 Statistical Evaluation of Work and Determination of Pay Factor (Value of Work) 106.06 Inspection at the Plant 106.07 Partial and Final Acceptance Section 107 LEGAL RELATIONS AND RESPONSIBILITY TO THE PUBLIC 107.01 Laws To Be Observed 107.02 Protection and Restoration of Property and Landscape 107.03 Bulletin Board 107.04 Railroad Protection 107.05 Responsibility for Damage Claims 107.06 Contractor's Responsibility for Work 107.07 Furnishing right-of-way 107.08 Sanitation, Health, and Safety 107.09 Legal Relationship of the Parties 107.10 Environmental Protection 107.11 Protection of Forests, Parks, and Public Lands. Section 108 PROSECUTION AND PROGRESS 108.01 Comments on Prosecution, and Completion of Work 108.02 Subcontracting 108.03 Determination and Extension of Contract Time 108.04 Failure to Complete Work on Time 108.05 Stop Order DIVISION 200 EARTHWORK Section 201 Clearing and Grubbing 202 Additional Clearing and Grubbing 203 Removal of Structures and Obstructions 204 Excavation and Embankment 205 Rock Blasting 206 Reserved 207 Earthwork Geotextiles 208 Structure Excavation and Backfill for Selected Major Structures 209 Structure Excavation and Backfill</p>
--	--

**DIVISION 150 PROJECT
REQUIREMENTS**
Section 151 Mobilization
152 Construction Survey and Staking
153 Contractor Quality Control

210 Permeable Backfill
211 Roadway Obliteration
212 Linear Grading
213 Subgrade Stabilization

A.5 – Sample Contract Agreement Clauses

Source: Powell-Smith, V., and Sims, J. (1985) " *Contract Documentation for contractors*". William Collins Sons & Co., London, England.

Articles of agreement and other clauses that cover various issues of concern to parties:		
A.5.1 – Parties Intentions		
No.	Agreement Title or Section	Comments
1.1	Contractor's Obligations	
1.2	Quality and quantity of work	
1.3	Priority of contract documents	
1.4	Contract bills	
1.5	Custody of Contract Documents	
1.6	Instructions as to errors, omissions, or inconsistencies	
1.7	Drawings and details	
1.8	Limits as to the use of documents	
1.9	Issue of completions certificates by CM or consultants	
1.10	Property transfer of fixed assets	
1.11	Off-site or non-fixed property transfer	

A.5.2 – Possession and Completions		
No.	Agreement Title or Section	Comments
2.1	Possession and completion dates	
2.2	Possession deferment	
2.3	Time extensions	
2.4	Further delays and time extensions	
2.5	Non-completions certificates	
2.6	Liquidated damages for non-completions	
2.7	Repayment of liquidated damages	
2.8	Practical or significant completions	
2.9	Defects liability	

A.5.3 – Control of construction operations		
No.	Agreement Title or Section	Comments
3.1	Assignments of work sections or packages	
3.2	Sub-contracting	
3.3	Persons named as sub-contractors	
3.4	Contractors' managers and persons in charge	
3.5	Consultants' supervisory person and instructions	
3.6	Variations	
3.7	Valuation or pricing of variations and provisions	
3.8	Instructions to spend provisional sums	
3.9	Levels and setting out for site work	
3.10	Works that are not in the contract or agreed on earlier	

3.11	Inspection procedures and tests	
3.12	Work failure and inspections necessary	
3.13	Instructions as to the removal of works and operations	
3.14	Instructions as to postponements of work activities	

A.5.4 – Payments

		Comments
4.1	Contract Sum	
4.2	Interim Payments	
4.3	Interim payments for substantial completions	
4.4	Withheld amounts and percentages	
4.5	Computation of contract adjusted sum	
4.6	Issue of final certificate	
4.7	Final certificate effects	
4.8	Other non-final certificates	
4.9	Price fluctuations and inflation	
4.10	Interference and disruption of normal process	

A.5.5 – Statutory Obligations

		Comments
5.1	Statutory obligations, notices, fees and charges	
5.2	Notice of divergence from statutory requirements	
5.3	Contractor's liability for non-compliance	
5.4	Emergency compliance	
5.5	Taxes	
5.6	Tax deductions and credits	
5.7	Wages and trade union rates	

A.5.6 – Injuries, Damages, and insurance

		Comments
6.1	Injury or damages to persons or property	
6.2	Employer's indemnity	
6.3	Liability insurance for damages and site injuries	
6.4	Group joint name insurance of works and property	
6.5	Employers' sole risks in new construction	
6.6	Employers' sole risks in existing construction	

A.6 – Sample Contract Requirements Procedure Statements

Source: ATISD Standard Engineering Process (ASEPH Compliance Guide) Handbook Version 1.0
Appendix G February 2000.

A.6.1 – Sample procedure Statement for Request for Quote or Proposal

Procedure: RFQ Response Generation (Small Delivery/Task Orders)	
Issue Date: May 2000	Procedure ID: <i>Abc AbL</i>
Supersedes: December 22, 1999	Revision 2.0

1. **Purpose:** To identify the activities necessary to respond to a Request for Quote (RFQ) for a small task or delivery order under an existing contract
2. **Applicability:** This procedure is applicable to all Contractor personnel assigned to ATISD
3. **Responsibility:** Contractor Program Manager
4. **Support:** Line management, Contracts, Engineering staff
5. **Invoked By:** Standard Process
6. **Inputs:**
 - RFQ, contract modification, or ECP
 - Cost Summary Sheet S- -300
 - Statement of Work (SOW) S- -010
7. **Outputs:**
 - Response to RFQ
 - List of assumptions used to generate response
8. **Procedures Invoked:**
 - Conduct Planning Meeting P- -030
 - Estimating Schedule P- 180
 - Estimating Effort P- -175
9. **External Procedures Referenced:** N/A
10. **Procedure Steps:**
 - a) The Contractor Program Manager reviews the RFQ and the associated SOW, contract modification, or ECP to determine the scope of the required response.
 - b) On large contracts, the Contractor Program Manager conducts a planning meeting (P-KKAL).
 - c) If contracts have not been notified of the RFQ activity, the Contractor Program Manager notifies the appropriate contracts representative.
 - d) The Contractor Program Manager assigns technical staff to develop technical estimates.
 - e) The Engineering Staff develops the required technical estimates using PE-17 and P-P-18 as applicable.
 - f) The Engineering Staff and Contractor Program Manager documents all assumptions used to generate the estimates.

- g) The Contractor Program Manager and Contracts prepare the cost proposal using the cost Summary Sheet (E-3).
- h) The Contractor Program Manager submit estimate(s), assumptions, basis of estimates, and cost response for pre-contractual management review and resolve all comments.
- i) Contracts prepare and submit the final response.
- j) The Contractor Program Manager files the RFQ, basis of estimates, and assumptions with the lead organization contracts office.

11. Notes:

The RFQ can be associated with a Statement of Work (SOW) for new or additional work, a contract modification of an existing task, or an Engineering Change Proposal (ECP) to change existing requirements.

A.6.2 – Sample Procedure Statement for Work Status

Standard: Statement of Work (SOW)	
Issue Date: May 2000	S- -010
Supersedes: January 2000	Revision 2.0

1. Purpose: To receive information about the proposed project from the Customer.

2. Creating Procedures:
P-PM-010 - Analyze Request
P-PE-010 - Define the Approach

3. Contents:

- a) Scope of the Work
- b) Technical goals and objectives
- c) Identification of customers and end users
- d) Imposed Standards
- e) Assigned responsibilities
- f) Cost and Schedule constraints and goals
- g) Dependencies between the software project and the Customer

4. Format:

A.6.2.1.1 Government Specified

5. Notes:
The Statement of Work should contain the information listed in the Contents section of this standard. The Government Program/Project Manager defines the format. The Statement of Work should be placed in the Project Records.

A.6.3 – Sample Procedure Statement for a Meeting Agenda

Standard: <i>Project Status Meeting Agenda</i>	
Issue Date: May 2000	Standard No.
Supersedes: October 1999	Revision 2.0

- 1. Purpose:** To share information among the team members as well as assessing status
- 2. Creating Procedures:**
PLK-030 Project Status Meetings
- 3. Contents:**
 - a) **Project ID:** the name/ID of the project to be reviewed
 - b) **Prepared By:** the name of the person creating the meeting agenda
 - c) **Date:** the date the meeting is to be held
 - d) **Location:** the location where the meeting is to be held (city, building, address, room number, or a subset of these, as appropriate)
 - e) **Purpose:** the name or purpose of the meeting
 - f) **Agenda:** a list of topics to be covered, optionally with times and names of the presenters. (See attached sheet for example.)
 - g) **Additional Instructions (optional):** information such as who to contact for more information, where to send security clearances, etc.

5. Format

6. Notes:

Regular staff meetings are an important means of sharing information among the project staff, as well as of assessing status. These meetings are usually held weekly but may be held biweekly if desired. This standard defines the topics that should be covered. (Not all topics will have to be discussed every week.) Meetings should be limited to 1.5 hours, with a goal of one hour).



Appendix B *UML, DFD & ER Modeling Languages Notations*

B.1 – Unified Modeling Language UML Notation Guide

UML by Booch et al.¹: Used to streamline software development by consistently synchronizing software component development with the Object Oriented model of information. Compiles a host of modelling facets: 1) Functional, 2) Dynamic, 3) Object Oriented, 4) Use Cases, 5) Sequence Diagrams, and 6) packaging.

Use Case Sequence Diagram

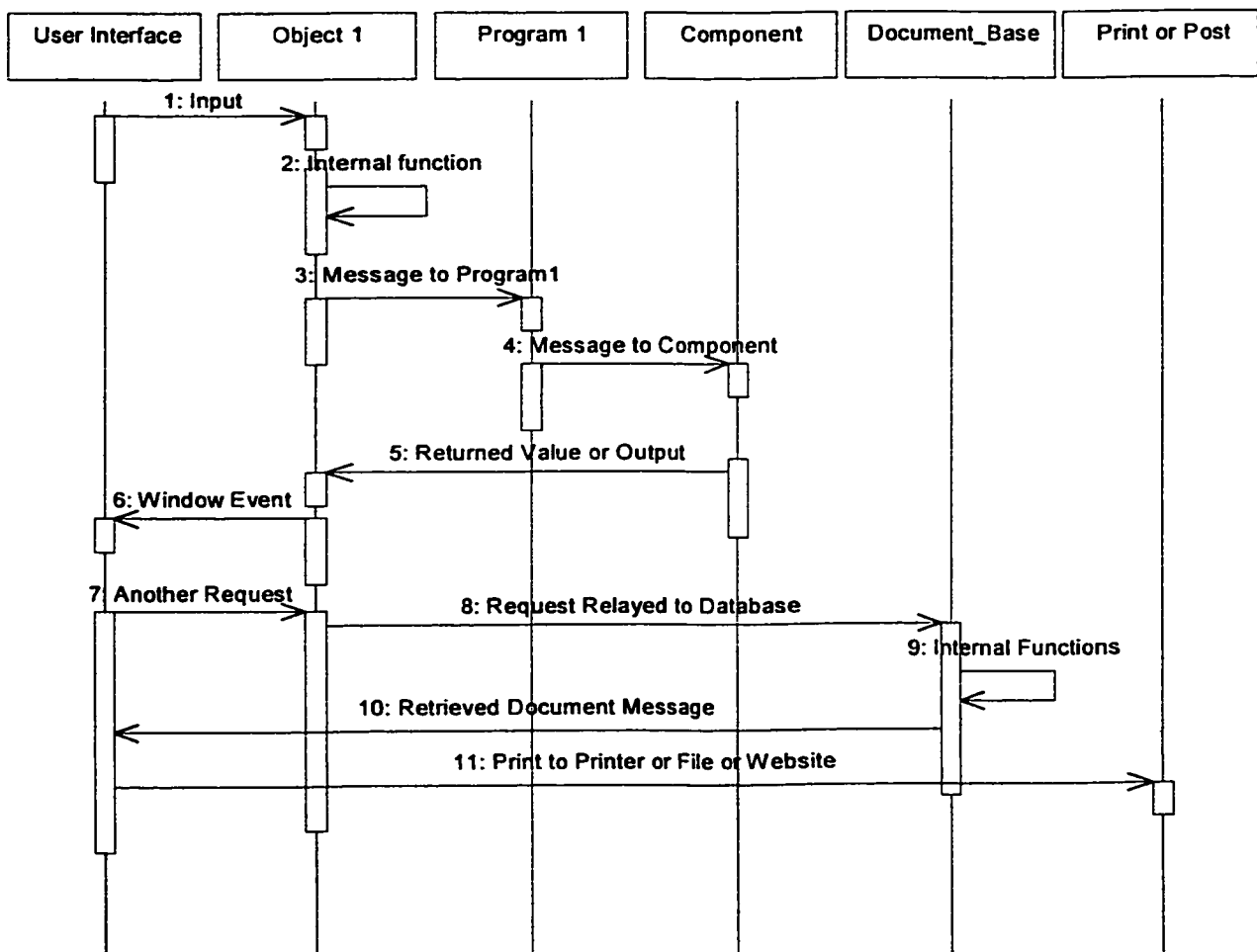

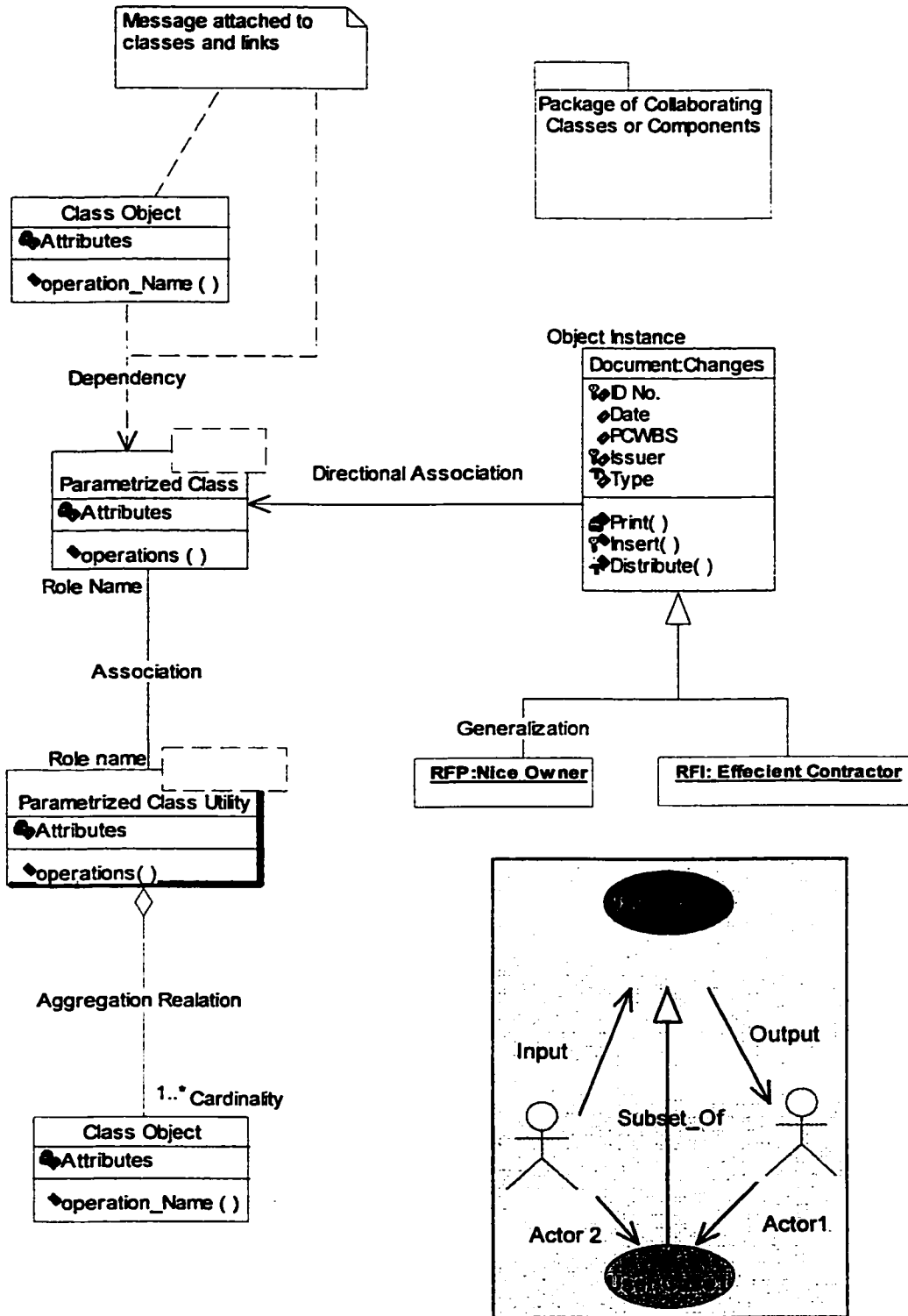

Components Diagram

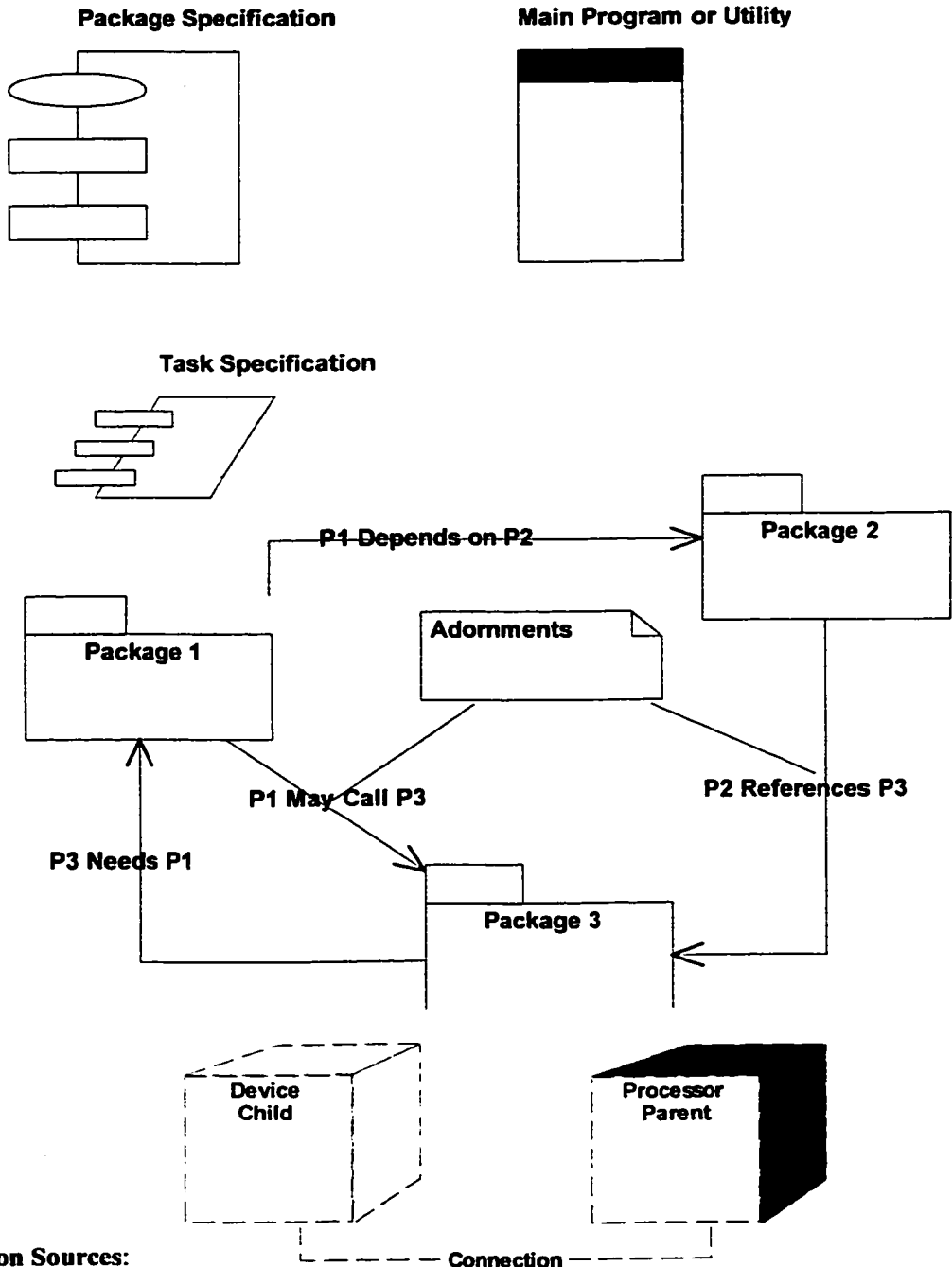

Notation Sources:

- 1) Booch, G., Rumbaugh, J., & Jacobson, I. 1998 "*The Unified Modeling Language User Guide*". Addison Wesley Longman Inc. USA.
- 2) Eriksson, Hans-Erik, and Penker, Magnus. 1998 "*UML ToolKit*". John Wiley & Sons, USA.

B.2 – Data Flow Diagram (Functional Modelling Notation Guide)

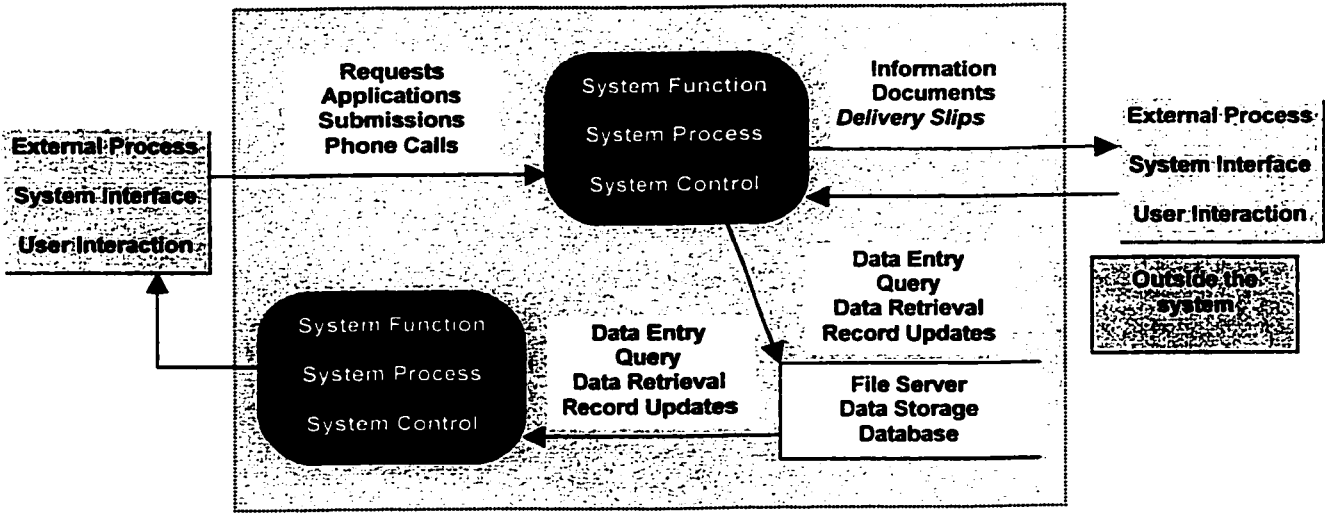

B.3 – Entity Relational Data Modelling Notation

Two modelling techniques used in this research are presented here for reference. The first one is the Crow foot or James Martin³ method. Referred to as Information Engineering method as well. the second method is the Entity Relational (ER) method by Chen⁵.

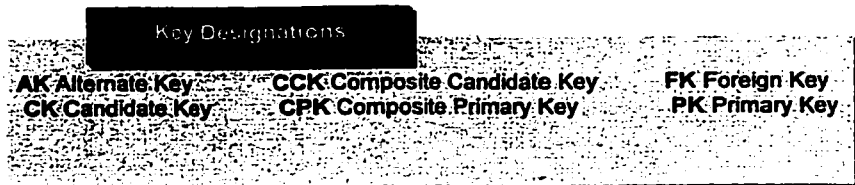
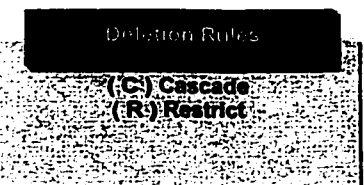
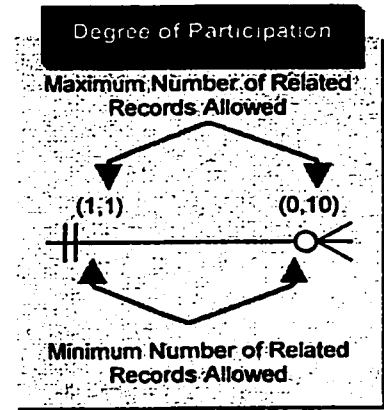
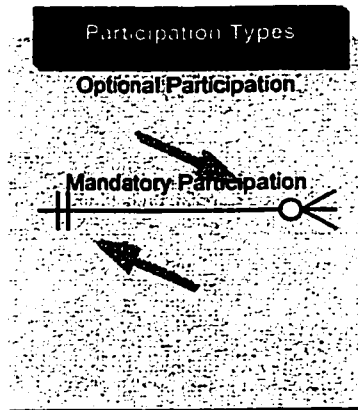
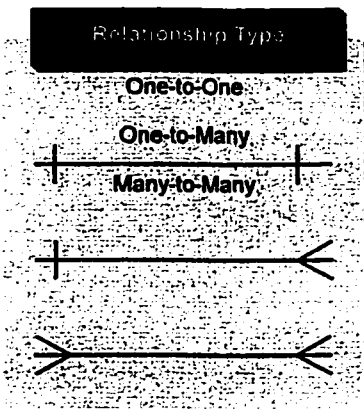
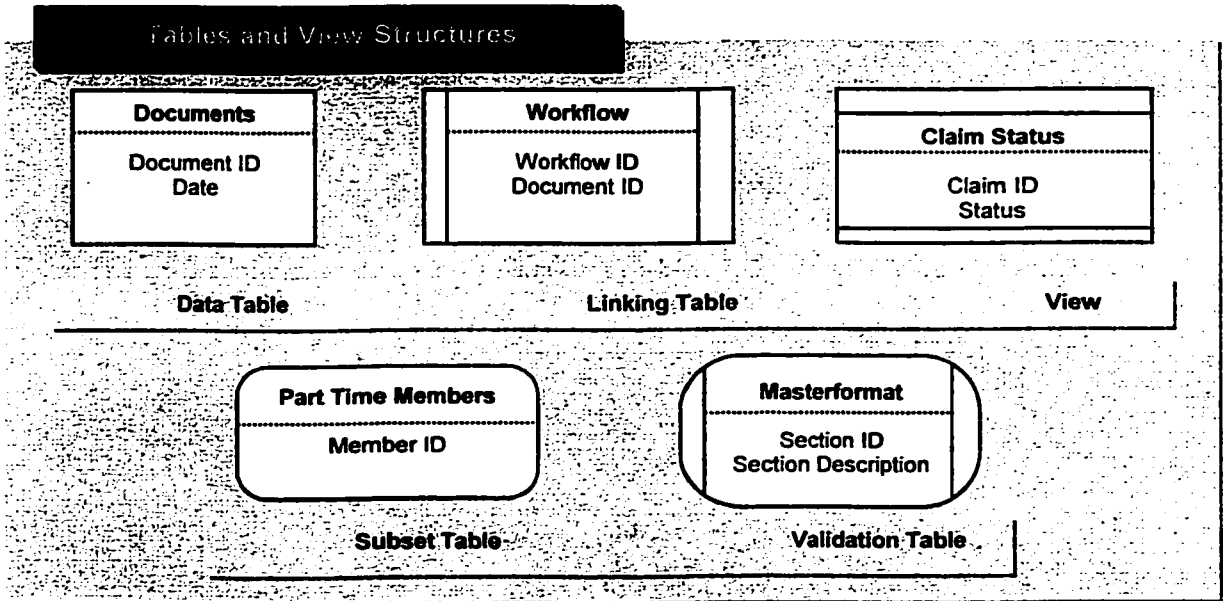

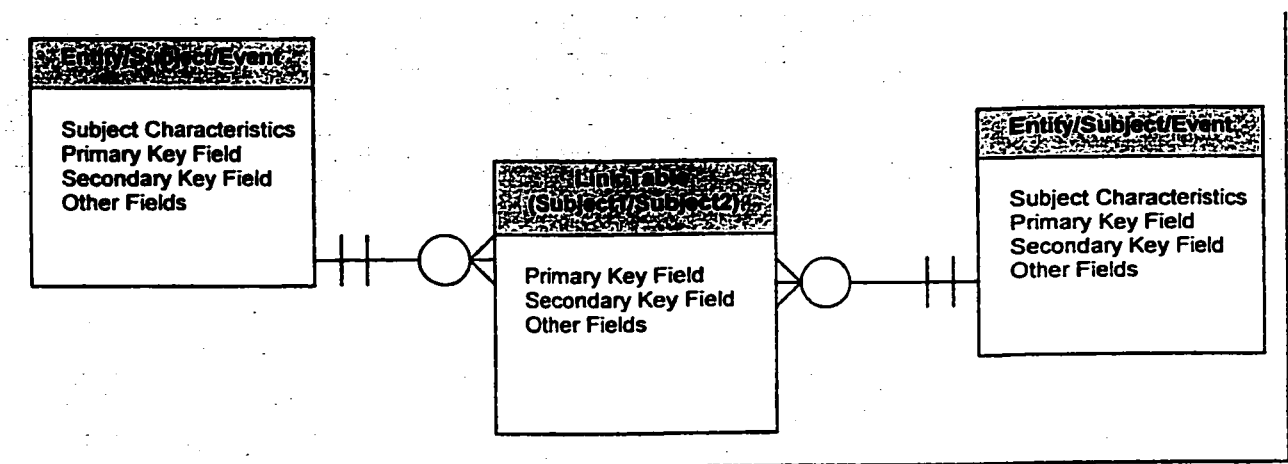
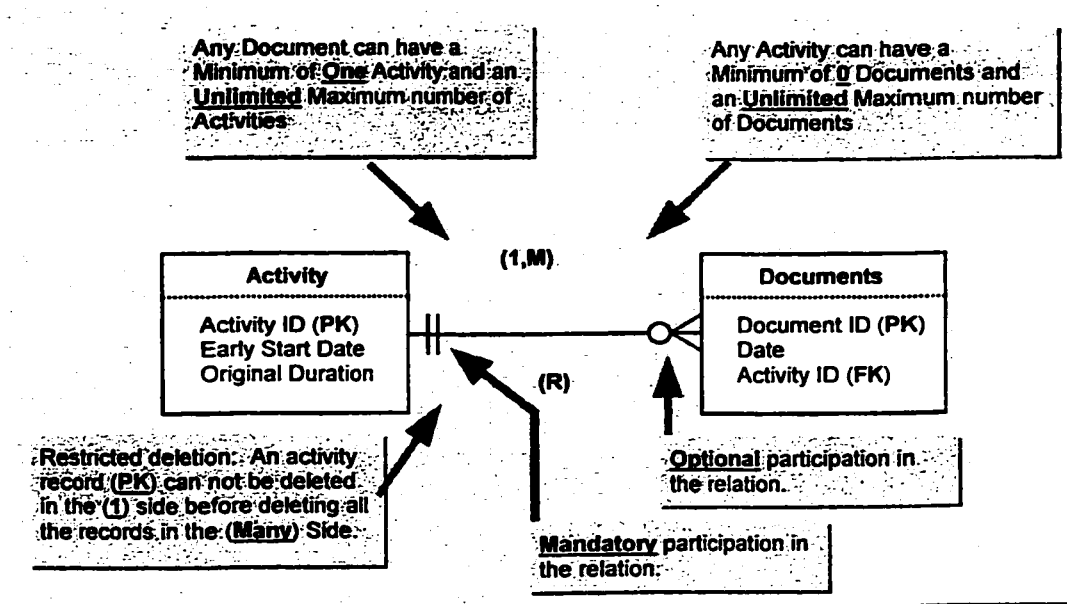







Notation Sources:

3) James, Martin. 1987 "Recommended Diagramming Standards for Analysts and Programmers". Englewood Cliffs, New Jersey, Prentice Hall.

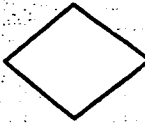
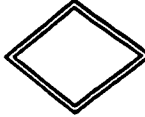
4) Hernandez, Michael J. (1997), "Database Design for Mere Mortals: A Hands-on Guide to Relational Database Design". Addison-Wesley Longaman Inc. USA.

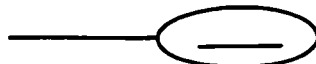
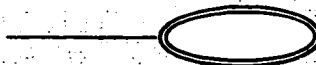
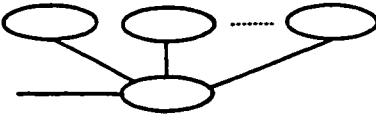
B.4 – Summary of ER (Entity-Relational) Diagram Notation

Symbol	Meaning
	Entity Type
	Weak Entity Type
	Relationship Type
	Identifying Relationship type
	Attribute
	Key Attribute
	Multi-Valued Attribute
	Composite Attribute
	Derived Attribute

Notation Sources:

5) Peter Chen. 1977 *"The Entity-Relationship Approach to Logical Data Base Design"* Wellesley, MA:QED Information Sciences, Inc

6) Elmasri, Ramez, & Navathe, Shamkant B. 1994 *"Fundamentals of Database System"*. 2nd edition, The Benjamin/Cummings Inc, USA.

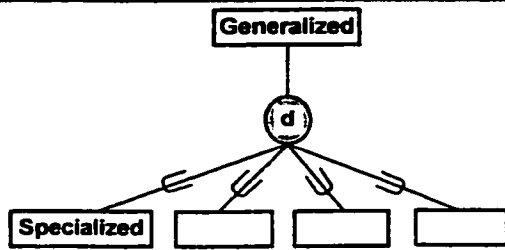

EER:(Extended ER) Specialization-
Generalization: Generalized Entities are sub-
types of the top super class.



Cardinality Ratio of 1:N for E₁:E₂ in R

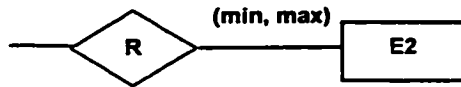

Structural Constraint (min, max) on
Participation of E in R

Sources:

5) Peter Chen. 1977 "The Entity-Relationship Approach to Logical Data Base Design" Wellesley, MA:QED Information Sciences, Inc.

6) Elmasri, Ramez, & Navathe, Shamkant B. 1994 "Fundamentals of Database System". 2nd edition, The Bejamin/Cummings Inc, USA



Appendix C *Sample Expert Survey Questionnaire*

C.1 – Introductory Letters Sent to Experts

<p>M A M O O N M O H A M M A D H A M M A D Ph.D. Program, Construction Management Center For Building Studies. Building, Civil, & Environmental Engineering. Concordia University. Montreal, Quebec, Canada</p>	
Mr./Mrs. EXPERT NAME CONSULTANT INC. 999 Street Address Montreal, Quebec, Canada Tel: (777) 123-9999	February 99
<p>Dear Mr./Mrs Expert</p> <p>Currently I am working on my Ph.D. thesis with Dr. Sabah Alkass. As part of my research, I am developing a Project Information System to serve the project participants, as well as claims' experts, by making any project's <i>story</i> readily available for analysis, and especially after a project's closure. The quality and organization of data are being the encompassing issue and motivator for the creation of a Project MIS.</p> <p>As you well know, time spent in search and retrieval is quite a concern to all those involved in claims: experts, owners, legal aides, and engineers. I intend through my work to facilitate the search and retrieval of project information for claims assessment and resolution. It is imperative for me to learn about the problems you face in your work with project documentation and suggestions to solve them. What are your expectations, as a claim's specialist, from a project information system in terms of data content and presentation, user functions, search criteria, data model views, and the output shapes and fashion.</p> <p>Mr./Mrs. Expert In the next few days I will contact you to set an appointment at a suitable time. This meeting will assist me in my research work on developing the information model specifications. Your expert opinion and input will be highly valued and recognized. Thanks</p> <p>Sincerely</p> <p>Mamoon Hammad</p>	

C.2 – Survey Meeting Agenda With Expert to Answer the Questionnaire

Mamoon Mohammad Hammad
Ph.D. Program, Construction Management, Concordia University

Meeting Agenda

Meeting with Mr./Mrs. Expert
Title
Address

February 1999

Introduction to my research

- Developing a Document Management system for construction projects
- This system will be part of a Project MIS
- The MIS is a framework modeled after any project's operation or business process
- The system will automate some of the repetitive and time consuming documentation tasks
- A database capturing project documents is part of the development
- The database will be searchable in different ways or views
- All the parties of the project will benefit and share in the system

Your Expertise will help

- Identify problems with documents and documentation that you frequently meet in your line of work
- Introduce practical user functions and views of the contents of the system, which will facilitate the search for interlinked documents
- Sort documents according to importance and impact on proof of cause and entitlement
- Define the levels of admissibility of documents to dispute resolution boards or courts

How you will benefit

- Your comments and opinions will be acknowledged in my work
- You will have a chance to test and validate the system I intend to develop in this research
- Your comments and recommendations about the prototype system will take serious consideration

Thank you

C.3 – Questions included in every Interview Questionnaire

Questionnaire: Please comment on or Answer the following inquiries

- 1) Is there a relation between the project contract value and the number of documents generated?
- 2) If yes, then on average how many documents are generated in a medium to a large size project?
- 3) Is there a relation between the type of the project (e.g. industrial; commercial; infrastructure....) and the number of documents generated from that project?
- 4) Which project type generates more documents and records?
- 5) Which project delivery system creates the least disputes?
- 6) What are the problems that you face with construction project documents? Like organization; format; completeness; missing related data; ...etc.
- 7) Which documents you perceive to be the most important in a project?
- 8) Should all the documents used in a claim dispute be shared among the parties during the project?
- 9) If a contractor has records of production and resource utilization that he did not distribute to the owner or engineer during the project, could he still be able to admit them to disputes?
- 10) You need to analyze a Change Order, which documents you must have?
- 11) A contractor wants to better document for a C.O.s impact, which documents he has to create and file?
- 12) To analyze a delay, which documents you must have?
- 13) Please chart the steps that you usually take to process documents after receiving them
- 14) After reviewing documentation for a project, what are the documents (e.g. summaries....) that you usually generate?
- 15) Which software or utility program do you currently use to classify and index documents?
- 16) How much is the percentage of your time is spent locating documents?
- 17) Which documents carry more weight in claim resolution?
- 18) How do you index documents?
- 19) How do you retain and maintain paper-based documents after preparing a claim case?

C.4 – Survey of User Specifications for future Web-Based Document Search and Retrieval Portal

Questionnaire: Please comment on or Answer the following inquiries

Designing the Web User Interface

This interview is designed to elicit feedback from professionals in the Claims domain, on the feel and functionality of the Document Center Website. The feedback is to be analyzed further and reinvested into the Website design for improvement and changes. Two main concerns are the focus here:

- 1) Navigation:
 - a. Ease of navigation
 - b. Finding information where it is expected to be
 - c. Website depth (3 or 4 levels...etc.)
 - d. Knowing where you are in every page, and being able to go back, forward, up, or down the website information structure.

- 2) Friendliness of the interface
 - a. Color scheme
 - b. Page organization
 - c. Legibility
 - d. Uniform features in all pages
 - e. Images
 - f. Information and functionality
 - g. Query form design

- 3) Search forms:
 - a. Presentation of search results
 - b. Two questions related to search are asked:
 - i. for a certain issue, dispute, or case at hand, which documents you look for besides the normal line of contracts, and specifications
 - ii. if you know you need a certain document, how do you look for it, what are the parameters that you would use to locate it.