

ANALYSIS OF A ROUND CORNER OF A FLAT PLATE

Balla Keita

A MAJOR TECHNICAL REPORT

in the

Faculty of Engineering

**Presented in partial fulfilment of the requirements for
the Degree of Master of Engineering at
Concordia University
Montreal, Quebec, Canada**

April 1975



Balla Keita 1975

ABSTRACT

ABSTRACT

BALLA KEITA

ANALYSIS OF A ROUND CORNER OF A FLAT PLATE

Flat-Plate floors are a variation of flat-slab construction in which neither drop panels nor column capitals are used.

Here, the analysis and the design of a flat-plate corner without a support are presented. In addition to the selected method and design, other approaches to the problem are illustrated in order to justify the choice.

The purpose of this report is to present different alternatives for the design of a round corner of a flat plate.

The main concern is the deflection problem. During the design, three design-alternatives were considered, and a fourth one is presented here.

ACKNOWLEDGEMENTS

ACKNOWLEDGEMENTS

The writer wishes to acknowledge with gratitude the following persons without whom the completion of his report would not have been possible:

His Supervisor, Dr. Zenon A. Zielinski for his encouragement and support;

Mr. Henry Markovits for typing this report;

Mr. Paul Roberge, Head of the Structure Department at Lalonde Valois & Associates, who permitted the use of the Office Computer for the slab band design.

TABLE OF CONTENTS

TABLE OF CONTENTS

	<u>PAGE</u>
ABSTRACT	i
ACKNOWLEDGEMENTS	11
LIST OF FIGURES, DRAWINGS, SCHEDULES AND TABLES	v
NOTATION	vii
1. INTRODUCTION	1
2. FLAT SLABS AND RELATED STRUCTURAL ELEMENTS	3
2.1 The statics of a flat slab	3
3. METHODS OF ANALYSIS OF FLAT SLABS	11
3.1 Direct design method	12
3.1.1 Limitations of the direct design method	13
3.2 Equivalent frame method	14
3.2.1 Assumptions	15
4. ANALYSIS AND DESIGN OF FLAT PLATES AND FLAT SLABS BY COMPUTER - IBM 1130	17
4.1 Design procedures	20
4.1.1 Design alternative no. 1	20
4.1.1.1 Additional steel due to cantilever deflection	21
4.1.1.2 Minimum required depth (ACI Art.9.5)	24
4.1.1.3 Maximum allowable deflection (ACI Art. 9.5.2.4)	24
4.1.1.4 Moment in terms of deflection	25
4.1.2 Design alternative no. 2	27
4.1.2.1 Design of cantilever slab	29

	<u>PAGE</u>
4.1.2.2 Determining the effective moment of inertia	33
4.1.3 Design alternative no. 3	37
5. CIRCULARLY CURVED HORIZONTAL BEAMS WITH SYMMETRICAL UNIFORM LOADS	40
5.1 Concentrated load P at any position	40
5.2 Analysis with uniform loads	42
5.2.1 Example	50
5.2.2 Check of the section for the maximum ultimate moment in the Table 4	58
5.3 Combined torsion and shear	59
5.3.1 Discussion	59
5.3.2 Computation of the actual torsion and shear	63
6. CONCLUSIONS	66
6.1 Design alternative no. 1	66
6.2 Design alternative no. 2	68
6.3 Design alternative no. 3	69
REFERENCES	71
APPENDIX A - DRAWINGS AND SCHEDULES	72
APPENDIX B - COMPUTER INPUT AND OUTPUT	77

**LIST OF FIGURES, DRAWINGS,
SCHEDULES AND TABLES**

LIST OF FIGURES

<u>FIGURE</u>		<u>PAGE</u>
1	General layout of a flat slab	4
2	Cantilever beam design of corner	23
3	Slab band design - Design alternative No. 2	28
4	Layout and cross-section of the actual horizontal curved beam	41
5	Forces acting on a curved beam	43
6	Horizontal curved beam with uniform load, q	44
7	Geometry of the curved beam	46
8	Moment diagrams	55
9	Free-body diagram 1	6
10	Curved beam cross-section	43
11	Curved cross-section of a corner column	43

LIST OF DRAWINGS

<u>DRAWING</u>		<u>PAGE</u>
1	Typical floor plan layout	72

LIST OF SCHEDULES

		<u>PAGE</u>
1	Reinforcing Schedule 1 - Corner reinforcement	73
2	Reinforcing Schedule 2 - Corner reinforcement	74
3	Reinforcing Schedule 3 - Corner reinforcement	75

LIST OF TABLES

<u>TABLE</u>		<u>PAGE</u>
1	Value of μ	49
2	Values of N	52
3	Values of M_f , M_t and ϕ	53
4	Flexural and Torsional Moments	56
5	Reinforcement per unit area	39

NOTATION

NOTATION

A_s	=	steel section, in ²
A_t	=	cross-sectional area of one leg of a stirrup.
a	=	depth of equivalent rectangular stress block, in.
a_u	=	$f_y(1 + 0.59q)/12,000$
b	=	width of compression face of member, in.
c	=	diameter of column capital, in.
d	=	distance from extreme compression fibre, in.
E_c	=	modulus of elasticity of concrete, psi.
E_s	=	modulus of elasticity of steel, psi.
F	=	coefficient = $1.15 - C/L$
f	=	cost per square ft. in dollars
F	=	flexural coefficient, $bd^2/12,000$
f'_c	=	compressive strength of concrete, psi.
f_r	=	modulus of rupture of concrete
f_y	=	yield strength of reinforcing steel.
G	=	modulus of elasticity in shear
h	=	overall thickness of slab, in.
I_g	=	gross moment of inertia, ft ⁴
I_{cr}	=	moment of inertia of cracked section, ft ⁴
I_e	=	effective moment of inertia, ft ⁴
J	=	polar second moment of area
J'	=	equivalent torsional second moment of area
k	=	effective length factor for compression member
K_u	=	flexural coefficient, psi., M_u/F
L	=	span, ft.

- l = span, ft.
 M = working flexural moment, ft-k.
 M_o = total static positive and negative moments, ft-k.
 M_{cr} = cracking moment, ft-k.
 M_u = ultimate flexural moment, ft-k.
 M_D = dead load moment, ft-k.
 M_L = live load moment, ft-k.
 M_f = bending moment of a curved beam, ft-k.
 M_t = torsional moment of a curved beam, ft-k.
 n = E_s/E_c , ratio of steel modulus of elasticity to concrete modulus of elasticity
 R = reaction, kips.
 r = radius of curvature, ft.
 s = shear or torsion reinforcement spacing
 T_u = design torsional moment
 v_{tc} = nominal permissible torsion stress
 v_u = nominal total design shear stress
 v_{tu} = nominal total design torsion stress
 W = total uniform panel load, lbs.
 x = shorter side of a cross-section
 x_1 = shorter dimension of a closed rectangular stirrup
 y = longer side of a cross-section
 y_1 = longer dimension of a rectangular closed stirrup
 α_t = a coefficient which is a function of y_1/x_1
 w = uniform load, lbs/ft.
 Δ = deflection, in.

Δ_D = dead load deflection, in.
 Δ_L = live load deflection, in.
 Δ_T = long term deflection
 ϕ = half-angle in degrees
 μ = EI/GJ

CHAPTER 1
INTRODUCTION

CHAPTER 1
INTRODUCTION

The structure analyzed here is part of an office building under construction between Prince Arthur and Park Avenues, in Montreal. All floors of this building are designed as flat, non-prestressed plates.

The general layout is such that it satisfies the architectural features. As a result, the columns near the round corners are staggered. If the corners were square (90° angle), it would be practical and easier to have a column at each corner. The walls being made in glass, are architecturally pleasing and require a round corner without columns.

It should be noted that what is architecturally desirable is not always structurally practical and economical. The prime responsibility of the engineer is to minimize the costs and to increase the efficiency of a structure. The choice of the design alternative No. 1, as described here, justifies this prime responsibility.

The columns are staggered on one side of each corner. This reduces the span of the round cantilever. If the columns were staggered on both sides of the corner, one would be less concerned with the problem of deflection.

But this layout is not possible because it would affect the architectural module and the set-up of the windows at each floor.

Our main concern in design of this structure has been to control the deflection. The floors are supporting non-structural elements which are likely to be damaged if deflections would be above acceptable.

For better efficiency of the structure, it was decided to have a drop around the column closer to the corner. The length of the drop is in the direction of the column strip having a cantilever at each end. Consequently, the cantilever becomes an elastic support.

The purpose of this report is to analyze the problem with different approaches and compare the advantages and disadvantages of each approach. The comparison is summarized in the conclusion.

CHAPTER 2

FLAT SLABS AND RELATED STRUCTURAL ELEMENTS

CHAPTER 2

FLAT SLABS AND RELATED STRUCTURAL ELEMENTS

A flat slab is a concrete slab so reinforced in two (or more) directions as to bring its load directly to supporting columns, generally without the help of any beams or girders. Beams are used where the slab is interrupted, as around stair walls, and at the discontinuous edges of the slab. The variations of the flat slab form are:

- (i) waffle slab
- (ii) flat plate (no drop, no capital) - see Fig.1 (p.4)
- (iii) flat slab with capital or drop panel

Two-way slabs supported on all sides by wide shallow beams also involve some flat slab action. Flat slabs, being thin members, are not economical in terms of consumption of steel, but they are economical in terms of formwork. Since formwork represents, in many cases, over half the cost of the reinforced concrete, the economy of the formwork often means overall economy. For heavy live loads, that is, over 100 psf, flat slabs have long been recognized as the most economical construction.

2.1 THE STATICS OF A FLAT SLAB

In 1914, J.R. Nichols⁴ through research work proved

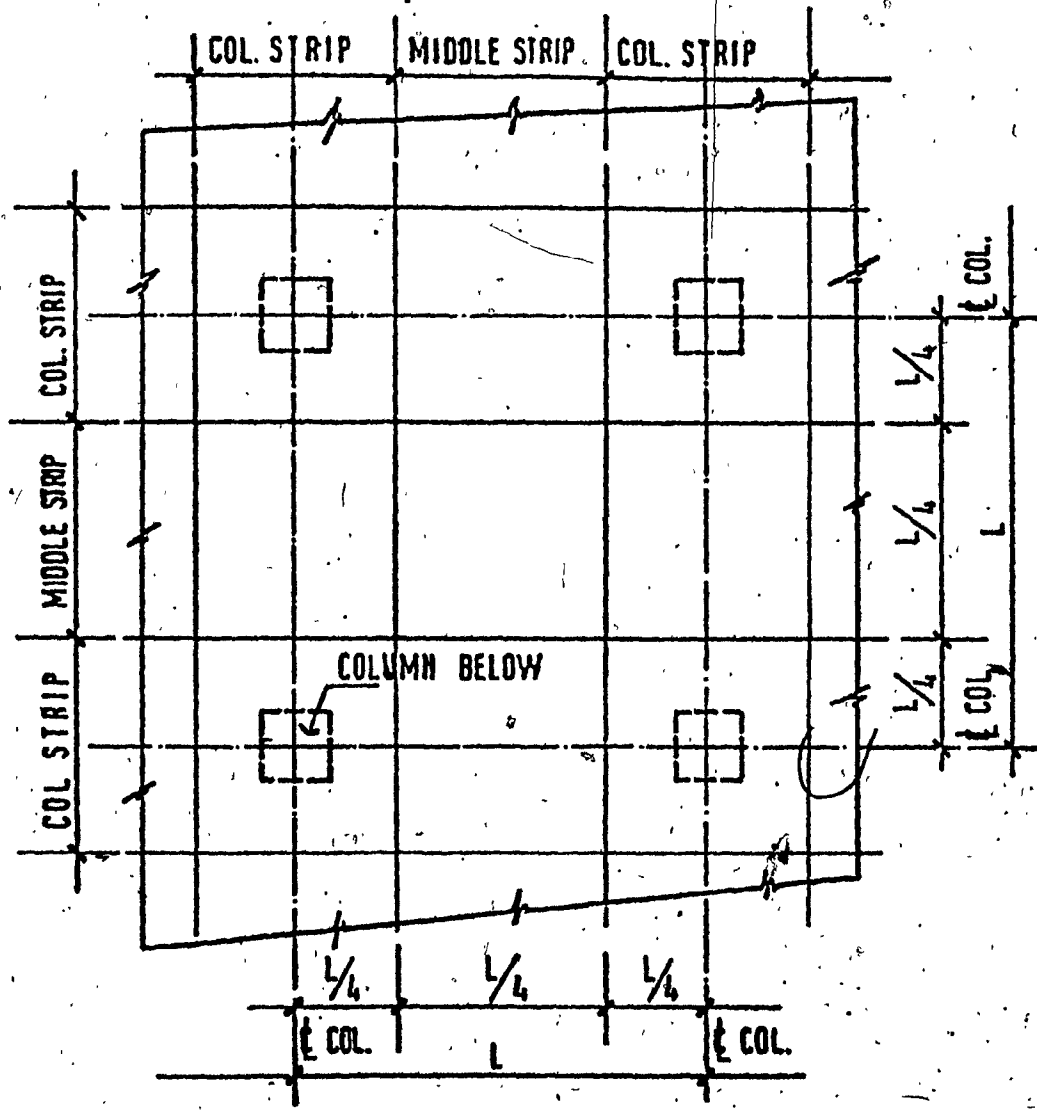

FIG. 1

General layout of a flat slab

that it is required to design flat slabs for positive and negative moments equal to

$$M_0 = \frac{1}{8} WL \left(1 - \frac{2C}{3L}\right)^2 \quad (1)$$

where:

W = total uniform panel load.

L = span.

C = diameter of column capital.

This conclusion has been derived from an analysis of a half panel, considering the interior panel as a free-body shown in Fig. 9 (p.6), surrounded with similar panels all loaded with a unit load w . The straight boundaries of the slab are all lines of symmetry, indicating that they are free from shear and torsion. Hence, all the shear and torsion must be carried around the curved corner sections which follow the column capital, or column if there is no capital. Likewise, if the slab is subdivided along the middle of the panel, this line is a line of zero shear and torsion. Thus the free bodies lb, lc are subject to a downward load W_1 acting at the centroid of the loaded area, an equal upward shear W_1 acting on the curved quadrants, the total positive moment M_1 acting on the middle section ab, and the total negative moment M_2 acting about the y-axis on section cdef. This assumes the bending moment around the column capital as uniformly distrib-

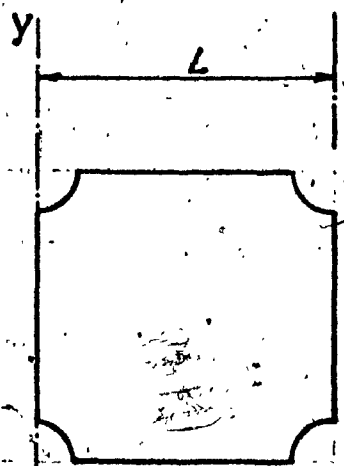

1a) interior panel loaded with a unit load w

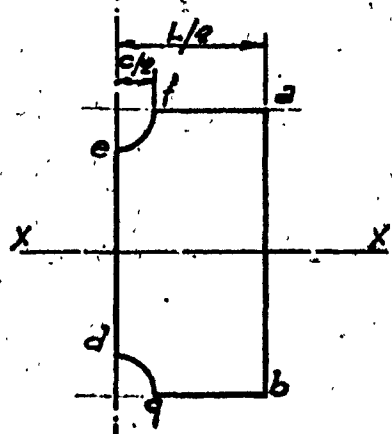

1b) half of interior panel

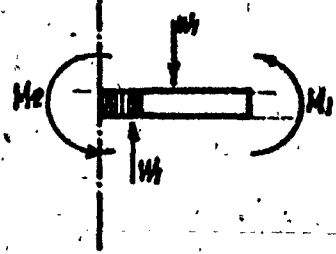

1c) an element of 1b) with the acting forces

FIGURE 9

Free-body diagram 1

ed, which means that no torsional moments exist there. Moments also exist about the x-axis on efa and deb, but these do not enter into $\sum M_y = 0$. The equation for the total shear force can be now described as :

$$W_1 = w(L^2/2 - \pi C^2/8)$$

$$= (L^2 - \pi C^2/4)w/2$$

where:

$$\frac{wL^2}{2} = \text{load on one half panel.}$$

$$\frac{w\pi C^2}{8} = \text{load subtracted because of the column capitals.}$$

C = diameter of column capital.

L = span.

w = unit load.

The moment of the load w about axis y-y is:

$$\frac{wL^2}{2} \times \frac{L}{4} - \frac{\pi C^2 w}{8} \times \frac{2C}{3\pi} = \frac{wL^3}{8} - \frac{wC^3}{12}$$

If the upward shear W_1 is considered uniformly distributed around the quadrants cd and ef, the resultant acts at a distance C/π from the y-axis. Equilibrium of moments about the y-axis then gives:

$$-M_1 - M_2 + \frac{wL^3}{8} - \frac{wC^3}{12} - \frac{w}{2} \left(L^2 - \frac{\pi C^2}{4} \right) \frac{C}{\pi} = 0$$

$$\begin{aligned} M_1 + M_2 = M_0 &= \frac{wL^3}{8} - \frac{wC^3}{12} - \frac{wCL^2}{2\pi} + \frac{wC^3}{8} \\ &= \frac{wL^3}{8} \left(1 + \frac{C^3}{3L^3} - \frac{4C}{\pi L} \right) \end{aligned}$$

$$M_0 = \frac{wL}{8} \left(1 - \frac{2C}{3L} \right)^2$$

For $C/L = 0.1$ the approximate method gives results about 0.5% lower than the exact value, for $C/L = 0.2$ the approximate method gives results about 0.5% higher than the exact value.

This static solution tells nothing about how this total moment is distributed between positive and negative moments or how either varies along the slab width. The solution also neglects possible torsional moments around the column capital which will act if the tangential bending moments are not uniformly distributed

For practical design purposes, a flat slab is divided into two strips in each direction, each strip being equal to one-half panel in width, as shown in Figure 1. Within these strips, the average moments are used for design rather than maximum moments. The column strip carries the heavier moments, and in design, controls the thickness of

slab for moment. The middle strip carries smaller moments, which call for less steel.

The Code¹ sets up two methods for computing these design moments. The first method is to establish the total negative and total positive moments in each direction from elastic frame analysis and then to separate these into moments on the column and middle strips on the basis of percentages set out in the Code. The second method, limited to regular slab layouts with at least three continuous panels, tabulates directly the empirical moment coefficients to be used for each design moment.

The Code³ provides that flat slabs may also be designed by ultimate strength method but requires two additional conditions to be met:

- (i) a minimum slab thickness of 13" in Table 7 of Article 9.4.
- (ii) the total design moment M_0 must also be increased from 0.09 to 0.10 to give:

$$M_0 = 0.10 WLF \left(1 - \frac{2C}{3L}\right)^2 \quad (2)$$

where $F = 1.15 - C/L$

but is not less than 1.0.

The slab band has the same depth as the other parts

of the flat plate. Therefore, its action under any sustained service load is intimately related to that of the surrounding part of the slab. For that reason, the minimum thickness required for a non-prestressed two-way construction should be at least:

$$h = \frac{r_n (800 + 0.005f_y)}{36,000} \quad (3)$$

In the case we will here analyze we have:

$$h = \frac{20 \times 12 (800 + 0.005 \times 50,000)}{36,000}$$

$$h = \frac{252 \times 10^3}{36,000} = 7''$$

But the minimum required depth of the slab band considered as a beam should be

$$h = \frac{r}{20} = \frac{21.67 \times 12}{20} = 13'' > t = 7\frac{1}{2}''$$

Since the beam depth is less than the minimum, the deflection must be computed and compared with the permissible value.

CHAPTER 3

METHODS OF ANALYSIS OF FLAT SLABS

CHAPTER 3
METHODS OF ANALYSIS OF FLAT SLABS

Before 1973, all flat slab structures were designed in accordance with a recognized elastic analysis subject to the limitations of sections 2102 and 2103 of the Building Code, ACI-318-63. Also, before 1973, the empirical design method given in section 2104 of ACI-318-63 was used for the design of flat slabs conforming with the limitations given therein.

Since the apparition of the new Building Code, ACI-318-71, most consulting engineers switched to using the ultimate strength design method and calculation of moments with: Direct design method or Equivalent frame method.

For a less regular layout or for slabs not satisfying article 2104 of ACI-318-63, where the empirical method cannot be used, the total moments will not be reduced to M_0 and the differences will be considerably greater. In such cases frame analysis procedure must be used.

Because of restrictions associated with the empirical method, the frame analysis procedure may be desirable even for regular layouts. The following limitations are applied when design is based on the empirical method:

1. Minimum of three continuous panels in each direction.

2. Length of panel not to exceed 1.33 times the width.
3. Successive spans not to differ by more than 20% of the longer span.
4. Columns not to be offset more than 10% of the perpendicular span.
5. Minimum column size and minimum column moment.

Now it can be seen that the Code allows the designer who uses an elastic analysis more flexibility because he is assumed to be more competent and more capable of establishing his own standards.

The Code describes two practical design methods: the Direct Design method and the Equivalent frame method.

3.1 DIRECT DESIGN METHOD

The direct design method consists of a set of rules for the proportioning of slab and beam sections to resist flexural stresses. The rules have been developed to satisfy the safety requirements and most of the serviceability requirements simultaneously. Methodologically, the direct design method compares with the empirical method for the flat slabs included in preceding editions of the ACI Code (American Concrete Institute). However, the range of applicability of the method has been much extended in relation to the empirical method.

The direct design method involves three fundamental steps, as follows:

1. Determination of the total design moment (Section 13.3.2 of ACI-318-71).

2. Distribution of the total design moment to design sections for negative and positive moments (Section 13.3.3 of ACI-318-71).

3. Distribution of the negative and positive design moments to the column and middle strips and to the beams, if any (Section 13.3.4 of ACI-318-71).

3.1.1 Limitations of the direct design method

1. There shall be a minimum of three continuous spans in each direction.

2. The panels shall be rectangular, with the ratio of the longer to shorter spans within a panel not greater than 2.0.

3. The successive span lengths in each direction shall not differ by more than one-third of the longer span.

4. Columns may be offset a maximum of 10% of the span, in direction of offset from either axis between center lines of successive columns.

5. The live load shall not exceed three times the dead load.

6. If a panel is supported by beams on all sides, the relative stiffness of the beams in the two perpendicular directions

$$\frac{\alpha_1 \ell_2^2}{\alpha_2 \ell_1^2}$$

shall not be less than 0.2 nor greater than 5.0.

$$\alpha = \frac{E_{cb} I_b}{E_{cs} I_s}$$

ℓ_1 = length of span in the direction moments are being determined.

ℓ_2 = span transverse to ℓ_1 .

α_1 = α in the direction of ℓ_1 .

E_{cb} = modulus of elasticity of concrete for beam.

E_{cs} = modulus of elasticity of concrete for slab.

I_b = moment of inertia about centroidal axis of gross section of a beam

I_s = moment of inertia about centroidal axis of gross section of slab.

α_2 = α in the direction of ℓ_2 .

3.2 EQUIVALENT FRAME METHOD

The equivalent frame method involves the representation of the three-dimensional slab system by a series of

two-dimensional frames which are then analyzed for loads, either vertical or horizontal, acting in the plane of the frame. The moments so determined at the critical design sections of the frame are distributed to the slab sections in accordance with Section 13.3.3 of the ACI-318-71 Building Code.

The equivalent frame method is comparable to the "elastic analysis" for slabs of the previous ACI Codes.

3.2.1 Assumptions

In design by the equivalent frame method the following assumptions shall be used and all section of slabs and supporting members shall be proportioned for the moments and shears thus obtained.

The structure shall be considered to be made up of equivalent frames on column lines taken longitudinally and transversely through the building. Each frame consists of a row of equivalent columns or supports and slab-beam strips, bounded laterally by the center line of the panel on each side.

Each such frame may be analyzed in its entirety, or for vertical loading.

The moment of inertia of the slab-beam or column at

any cross-section outside of the joint or column capital may be based on the cross-sectional area of the concrete.

The equivalent column shall be assumed to consist of the actual columns above and below the slab-beam plus an attached torsional member transverse to the direction in which moments are being determined.

Negative design moment and the distribution of panel moments shall be taken as stated in articles 13.4.2 and 13.4.3 of ACI-318-71.

The spacing of the bars at critical sections shall not exceed two times the slab thickness.

CHAPTER 4

ANALYSIS AND DESIGN OF FLAT PLATES AND
FLAT SLABS BY COMPUTER - IBM 1130

CHAPTER 4

ANALYSIS AND DESIGN OF FLAT PLATES AND
FLAT SLABS BY COMPUTER - IBM 1130

The program provides analysis and design capabilities for flat plates, flat slabs, waffle slabs, and continuous concrete frames. The program is written in FORTRAN IV language for the IBM 1130 computer. The present version of the program has been updated to conform to the provisions of the 1971 ACI-318 Building Code.

Program limitations and assumptions:

- (i) - maximum number of spans = 12 (with or without cantilevers at each end)
- (ii) - columns can be rectangular or circular
- (iii) - all members' depths are the same except for drop panel areas
- (iv) - the program can consider the slab widths to vary linearly from column to column
- (v) - uniformly distributed dead or live loads can act over the entire span and one partial live load and one partial dead load over part of the span only
- (vi) - material properties are the same throughout the entire structure except for Young's modulus E

(vii) - the columns are considered fixed at their far ends for the vertical load analysis

The program utilizes the equivalent-frame method of analysis and design in accordance with Section 13.4 of the 1971 ACI-318 Building Code. In this method, the structure is considered divided into a series of bents, each consisting of a row of columns supporting slab strips.

The input information consists of geometry of the structure, loading conditions, material properties, design method specifications and lateral load moments or lateral loads, if the combination of vertical and lateral load is required.

Input forms designed for data entries are kept to a minimum. The input data can be specified so that data common to several adjacent members need to be specified only once; the program arranges the data in proper arrays internally. It checks basic errors related to deck arrangements, data sequence, and completeness.

For either a column and flat slab structure or a column and beam frame, the program follows an appropriate sequence of operations to comply with the pertinent design criteria of the Code ACI-318-71. (ACI stands for: American Concrete Institute.) Logical branches are provided to accommodate lightweight or normal-weight concrete. Another

branch in the program allows either the alternate design method of ACI-318-71, Section 8.10 (working stress design method) or the ultimate strength design method.

Numerical integration is used to calculate carryover factors, stiffness factors, and fixed-end moments. The set of sets of simultaneous equations for each bent of the structure are solved by the elimination method.

Two aspects of shear in flat slab members, namely punching shear and moment-transfer shear, are treated together under the heading "Shear Stresses" (see the appendix "B"). It is assumed that both types of shear act on the same critical section. The critical section, as defined in Section 11.10.2 of the 1971 ACI-318 Building Code, is a peripheral vertical surface through the slab, located at constant distance of $d/2$ beyond the support faces.

Where drop panels are defined, a second periphery of punching shear is taken as the vertical surface through the slab, located at $d/2$ beyond the drop panel faces.

For shear due to moment-transfer, Section 11.13.2 of the Code¹ is used. The unbalanced moment at an interior joint is the algebraic difference between the end moments of the two continuous members; whereas at an exterior joint it is the member end moment.

If wind loads or wind load moments are specified, the

moments or shears at the section due to dead, live and wind loads are combined in accordance with Section 9.3 and 8.10.5 of the Code¹. Thus, if the ultimate strength method has been specified, the combinations of loading increased by factor of safety are considered as follows:

- 1) $1.4D + 1.7L$
- 2) $0.75(1.4D + 1.7L + 1.7W)$
- 3) $0.9D + 1.3W$

If the working stress method has been specified, the combinations considered are:

- 1) $D + L$
- 2) $0.75(D + L + W)$
- 3) $0.75(D + W)$

where: D = dead loads
L = live loads
W = wind loads

4.1 DESIGN PROCEDURES

4.1.1 Design alternative no. 1

As in any usual procedure, the slab was subdivided

into column and middle strips. The width of the column strip and the middle strip are equal to one half the distance between two columns. Therefore, the outside column strip is equal to one quarter of the distance between two columns.

In order to satisfy the architectural features, the general layout is such that the columns at the round corners are staggered. For simplicity of the design and for greater safety, a drop was placed around the column closest to the corner. Therefore, it is not necessary to investigate the yield-line theory for the failure pattern. In fact, the cantilever at the end of the column strip on axis (2) in Drawing No. 1, is considered as an elastic support of the last span of column strip on axis V_x . It should be noted that the cantilever is actually a column drop.

After an analysis by computer (with PCA program), a further analysis was necessary to determine the reinforcing steel required for maximum deflection limitation of the cantilever (see computer output). This involved the computation of the cracking moment M_{cr} , and the moment of inertia of the cracked section.

4.1.1.1 Additional steel due to cantilever deflection

(1) Data

$$f'_c = 4 \text{ ksi}$$

$$f_y = 50 \text{ ksi}$$

$$E_c = 547,000 \text{ k/ft}^2$$

$$A_s = 4.4 \text{ in}^2 \text{ (computer output)}$$

$$n = E_s/E_c = 8.0$$

$$\text{Cantilever Beam} = 11.42' \times 0.625'$$

$$\Delta = 0.074 \text{ in (computer output)}$$

$$b = 137", d = 6.75"$$

(ii) Free-body diagram:

(See Fig. 2, p. 23)

The free edge of the cantilever being round, it is assumed that the average cantilever length is 8' - 0".

$$M = \frac{wL^2}{2} \quad (4)$$

$$I_g = \frac{11.42 \times 0.625^3}{12} = 0.232 \text{ ft}^4$$

$$I_{cr} = \frac{b(Kd)^3}{3} + nA_s(d-Kd)^2 \quad (5)$$

$$Kd = \left(\sqrt{1 + 2 \frac{bd}{nA_s}} - 1 \right) nA_s / b \quad (6)$$

$$= \left(\sqrt{1 + 2 \frac{924.75}{35.2}} - 1 \right) 35.2 / 127 = 1.62"$$

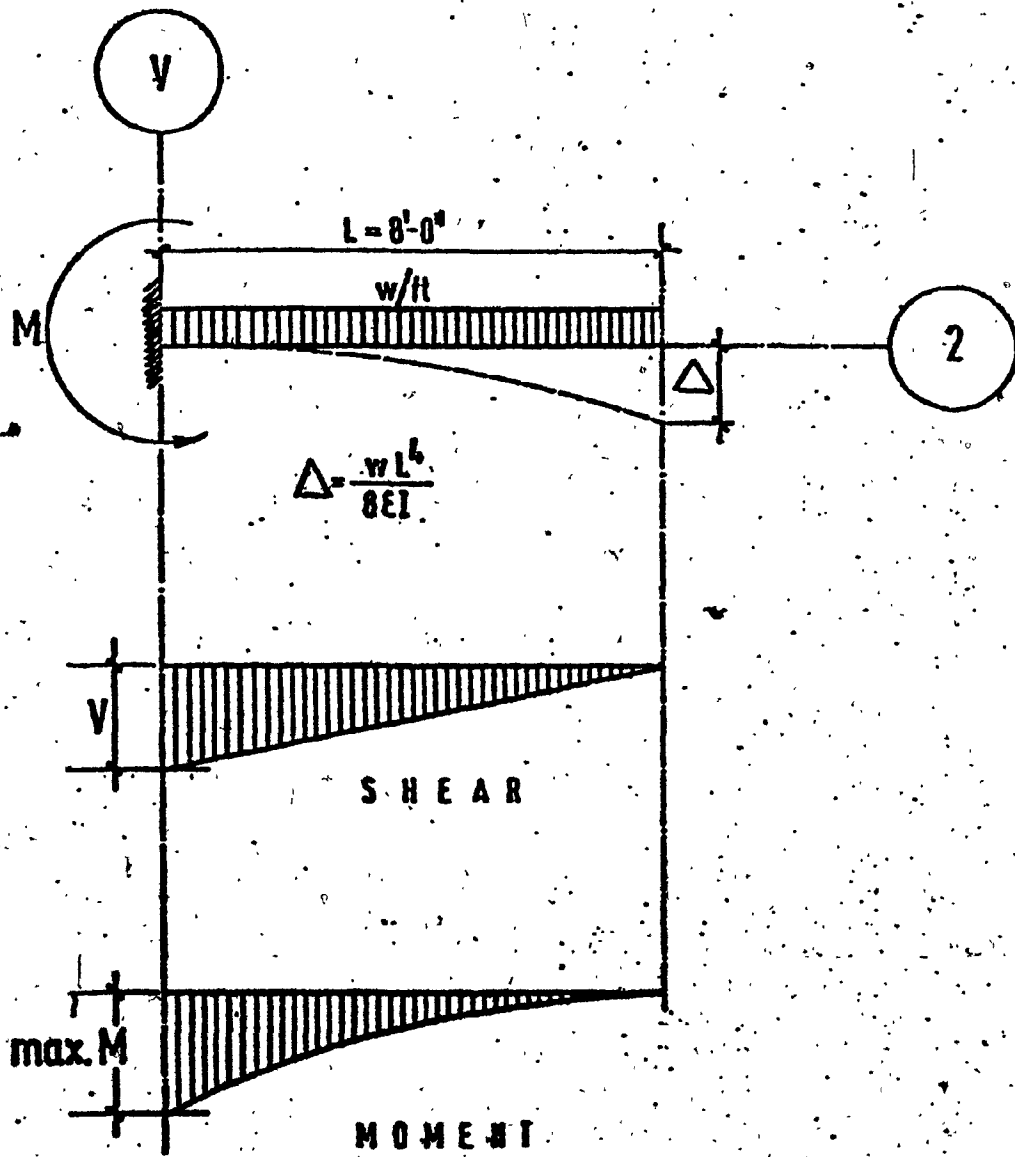

FIG 2

Cantilever beam

$$I_{cr} = 137 \frac{(1.62)^3}{3} + 35.2(6.75 - 1.62)^2$$

$$I_{cr} = 194.15 + 926.35 + 1120.50 \text{ in}^4$$

$$I_{cr} = 0.054 \text{ ft}^4$$

4.1.1.2 Minimum required depth (ACI Art.9.5)

$$t = \frac{R}{10} = \frac{8 \times 12}{10} = 9.6" > 7\frac{1}{2}"$$

Since the minimum required depth is greater than the actual depth considered, $t = 7\frac{1}{2}"$, an investigation of deflection was done by computer. The following deflections were obtained:

$$\Delta_{DL} = 0.024 \text{ in.}$$

$$\Delta_{LL} = 0.026 \text{ in.}$$

$$\Delta_T = 2 \times 0.024 + 0.026 = 0.074 \text{ in.}$$

These results are from the computer output in Appendix "B".

4.1.1.3 Maximum allowable deflection (ACI Art.9.5.2.4)

$$\text{max. allow. } \Delta = \frac{R}{480} = \frac{8 \times 12}{480} = 0.20 \text{ in.}$$

$$\text{max. allow. } \Delta = 0.20 > \Delta_T = 0.074 \text{ in.}$$

Cracking moment, M_{cr}

$$M_{cr} = \frac{f_r I_g}{Y_t} \quad (7)$$

$$f_r = 7.5 \sqrt{f'_c} = 474 \text{ psi} \quad (8)$$

$$M_{cr} = \frac{0.474 \times 4810.75}{3.75 \times 12} = 50.67 \text{ ft-k}$$

where: f_r = modulus of rupture of concrete, psi.

I_g = moment of inertia of gross concrete section
about the centroidal axis neglecting the reinforcement.

Y_t = distance from centroidal axis of gross section
to extreme fiber in tension.

f'_c = specified compressive strength of concrete, psi.

4.1.1.4 Moment in terms of deflection

$$\text{max } \Delta = \frac{\omega L^4}{8EI} = 0.074 \text{ in.} = 0.0061'$$

$$\omega = 0.0488 \frac{EI}{L^4}$$

$$M = \frac{\omega L^2}{2} = 0.0488 \frac{EI}{2L^2}$$

$$M = 0.0244 \frac{EI}{L^2}$$

(i) with $I_g = 0.232 \text{ ft}^4$

$$M = \frac{0.0244 \times 547,000 \times 0.232}{8^2} = 48.4 \text{ ft-k}$$

Additional reaction on column:

$$\Delta R = \frac{48.4}{8} = 6.05 \text{ K}$$

$$M_1 = 48.4 - \frac{6.05 \times 1.51}{3} = 45.35 \text{ ft-k}$$

$$M_u = 1.55 \times 45.35 = 70.3 \text{ ft-k}$$

(ii) with $I_{cr} = 0.054 \text{ ft}^4$

$$M_2 = \frac{0.0244 \times 547,000 \times 0.054}{8^2} = 11.26 \text{ ft-k}$$

$M_1 > M_2$, therefore consider only the moment

with I_g .

(iii) Additional steel due to $M_u = 70.3 \text{ ft-k}$

$$F = \frac{137 \times 6.75^2}{12,000} = 0.520$$

$$K_u = \frac{70.3}{0.52} = 135 + a_u = 3.64$$

$$A_s = \frac{70.3}{3.64 \cdot 6.75} = 2.86 \text{ in}^2$$

7#6 to be added to T3

(See Reinforcing Schedule No. 4)

Several factors make deflections particularly significant and their exact prediction is very difficult in reinforced concrete construction. Shrinkage, creep and loading are interrelated and any one cannot be said to be independent of the other two⁵. For these reasons, #5@12" was added at the bottom of the drop.

The reinforcing steel for design No. 1 is shown on drawing No. 1, and on reinforcing schedules 1 to 4. For the purpose of this paper it was not necessary to show the central core layout (shear walls and elevators), nor all reinforcing steel. Only the corner reinforcement is shown.

4.1.2 Design alternative No. 2

In alternative No. 2, a slab band between the two columns closest to the round corner of the slab is considered. The depth of the slab band is the same as that of the slab: 7½". (See Fig. 3, p.28).

Because of the removal of the steel form of the flat plate the slab band cannot be deeper than 7½" but it can be wider. Alternative No. 2, consists of two parts:

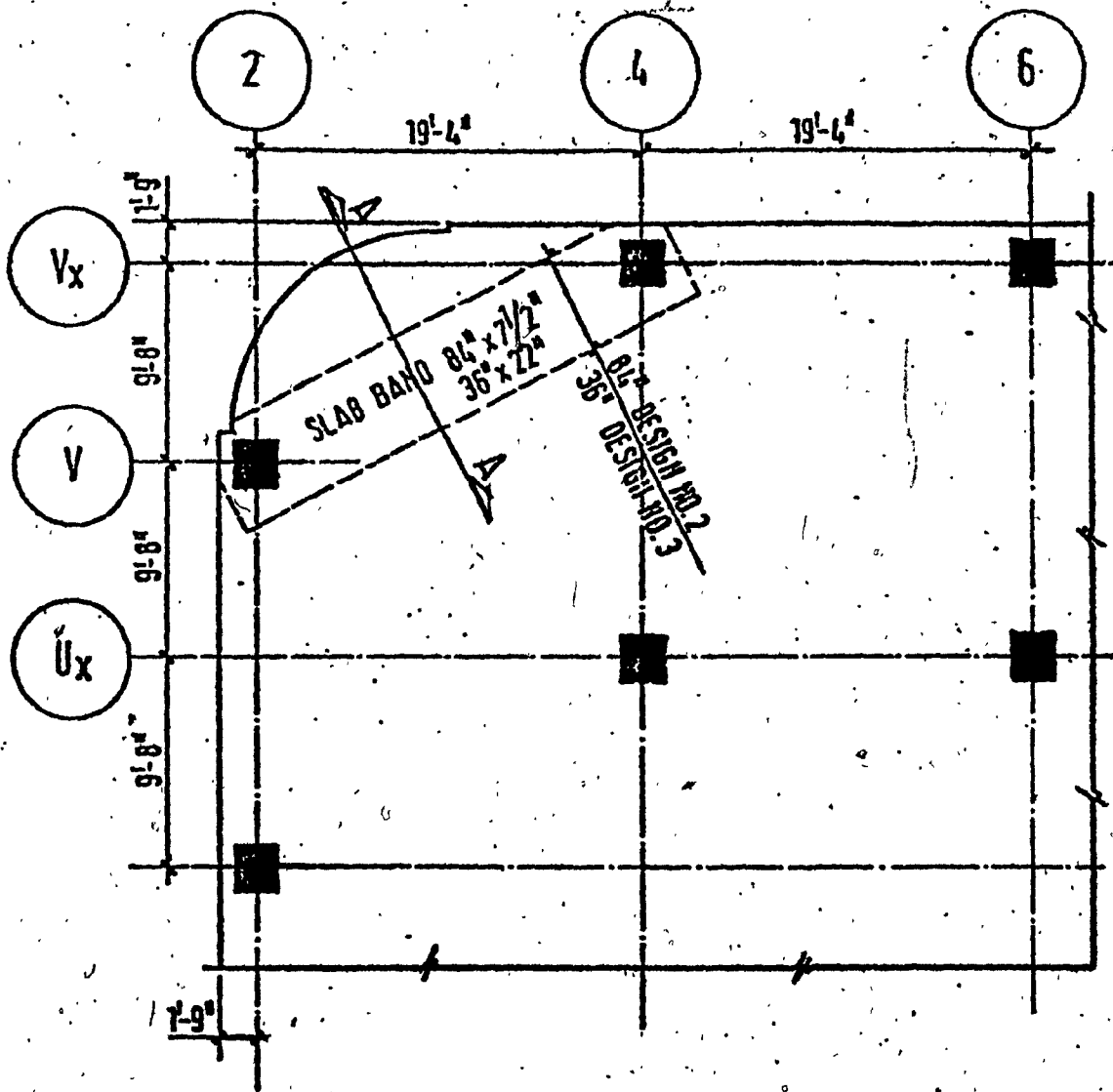

(a) PLAN OF CORNER

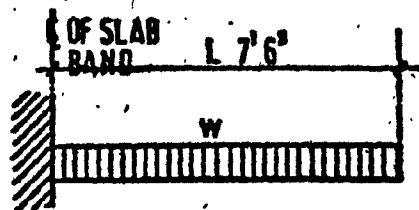

(b) SECTION A-A

FIG. 3

Design alternative No. 2 and No. 3

- (i) - design of the overhanging part of the slab
- (ii) - design of the slab band as a beam

4.1.2.1 Design of cantilever slab

(i) Loading:

7½" slab	=	94#/ft ²
partitions	=	20
ceiling (mech., electr., and ventilation)	=	10
DL. = 124 × 1.4 =		
173.6#/ft ²		
LL. = 50 × 1.7 = 85#/ft ²		

Wall on the slab edge = 500 × 1.4 = 700#/ft

The average cantilever length = 7.5'

(ii) Minimum required depth

$$t = \frac{l}{10} = \frac{7.5 \times 12}{12} = 9" > 7\frac{1}{2}"$$

Therefore the deflection shall be computed.

$$\omega = 173.6 + 85 + \frac{700}{7.5} = 352\#/ft^2$$

The maximum deflection Δ , at the free end of a cantilever beam with uniformly distributed load, ω in k/ft

is given by the formula: $\max \Delta = \frac{wL^4}{8EI}$

$$E_c = 547,000 \text{ k/ft}^2 = 3798.61 \text{ k/in}^4$$

$$I = \frac{12 \times 6.75^3}{12} = 307.6 \text{ in}^4 = 0.0148 \text{ ft}^4$$

$$\max \Delta = \frac{(7.5 \times 12)^4}{8 \times 3798.61 \times 307.6} = 0.0171''$$

$$\max. \text{ allow. } \Delta = \frac{L}{480} = \frac{7.5 \times 12}{480} = 0.188''$$

$$\max \Delta = 0.0171'' < \max. \text{ allow. } \Delta$$

Therefore the $7\frac{1}{2}''$ cantilever is adequate.

$$M_u = 0.2586 \times \frac{7.5^2}{2} = 7.27 \text{ ft-k}$$

$$0.700 \times 7.5 = 5.25$$

$$M_u = 12.52 \text{ ft-k/ft wide}$$

$$F = \frac{12 \times 6.75^2}{12,000} = 0.046$$

$$K_u = \frac{12.52}{0.046} = 275$$

$$a_u = 3.57$$

$$A_s = \frac{12.52}{3.57 \times 6.75} = 0.52 \text{ in}^2$$

#5 @ 7"

Dimensions of the slab band = 84" x 7½"

After investigation, it was found that for the limited overall depth of 7½" the most adequate width of the slab band would be 84".

(iii) The area of the overhanging slab:

$$(10.33 \times 21.08) - \frac{10.33^2}{6} =$$

$$= 217.756 - 17.785 = 200 \text{ ft}^2$$

(iv) Loads on the slab band

$$\text{wall} = \frac{500}{7.5} = 66.67 \text{ \#/ft}^2$$

$$7\frac{1}{2}" \text{ slab} = 94$$

$$\text{Partitions} = 20$$

$$\text{Ceiling} = 10$$

$$\text{DL} = 190.67 \times 1.4 = 267 \text{ \#/ft}^2$$

$$\text{LL} = 50 \text{ \#/ft}^2 \times 1.7 = 85$$

$$\underline{352 \text{ \#/ft}^2}$$

$$\text{Dead Load of slab band} = \frac{84 \times 7.5}{144} \times .150 \times 1.4 = 0.9188 \text{ k/ft}$$

$$\frac{0.352 \times 200}{21.67} = 3.249$$

$$\frac{\text{WA}}{3} = \frac{0.2586 \times 19.33}{3} = 1.666$$

$$W_{ut} = 5.834 \text{ k/ft}$$

Slab band span = 21.67'

Clear span = 20' - 0"

$$M_u = \frac{5.834 \times 20^2}{8} = 298.70 \text{ ft-k}$$

$$F = \frac{84 \times 6.75^2}{12,000} = 0.319$$

$$K_u = \frac{291.70}{0.319} = 914$$

$$a_u = 3.06$$

$$A_s = \frac{291.70}{3.06 \times 6.75} = 14.12 \text{ in}^2 \quad \#9 @ 6"$$

The slab band has the same depth as the other parts of the flat plate. Therefore, its action under any sustained service load is intimately related to that of the surrounding part of the flat plate. For that reason, the minimum thickness required for a non-prestressed two-way construction should be checked.

$$h = \frac{2 \left(800 + 0.005 f_y \right)}{36,000}$$

$$h = \frac{20 \times 12 (800 + 0.005 \times 50,000)}{36,000}$$

$$h = \frac{252 \times 10^3}{36,000} = 7"$$

(v) Minimum required depth of the slab band as a beam

$$h_{\min} = \frac{\ell}{20} = \frac{21.67 \times 12}{20} = 13" > t$$

Since the beam depth is less than the minimum required thickness, deflection must be computed.

4.1.2.2 Determining the effective moment of inertia

The formula used is given by ACI-318-71, Article 9.5.

$$I_e = (M_{cr}/M_a)^3 I_g + [1 - (M_{cr}/M_a)^3] I_{cr} \quad (9)$$

where

- I_e = effective moment of inertia
- M_{cr} = cracking moment
- M_D = dead load moment
- I_g = moment of inertia of gross area
- I_{cr} = moment of inertia of cracked section
- M_a = maximum moment in member at stage for which deflection is being computed.

$$I_g = \frac{bh^3}{12} = \frac{84 \times 7.5^3}{12} = 2953 \text{ in}^4$$

$$I_{cr} = b(kd)^3/3 + nA_s(d - kd)^2$$

$$kd = nA_s \left[\sqrt{1 + 2 \frac{bd}{nA_s}} - 1 \right] \frac{1}{b}$$

where $A_s = 15 \text{ in}^2$

$$n = E_s / E_c = 8$$

$$b = 84 \text{ in}$$

$$d = 6.75 \text{ in}$$

$$kd = \frac{8 \times 15}{15} \left(\sqrt{1 + 2 \frac{84 \times 6.75}{8 \times 15}} - 1 \right)$$

$$kd = 1.429(3.233 - 1) = 3.19$$

$$I_{cr} = 84(3.19)^3 / 3 + 8 \times 15(6.75 - 3.19)^2$$

$$I_{cr} = 909 + 1.521 = 2430 \text{ in}^4$$

$$M_{cr} = \frac{f_r I_g}{Y_t} \quad (10)$$

where f_r = modulus of rupture of concrete

Y_t = distance from centroidal axis of gross section, neglecting the reinforcement, to extreme fiber in tension

M_{cr} = cracking moment

I_g = moment of inertia of gross section

$$f_r = 7.5 \sqrt{f'_c}$$

$$f_r = 7.5 \sqrt{4000} = 474.3 \text{ psi}$$

$$M_{cr} = \frac{474.3 \times 2953}{3.75} = 373.5 \text{ in-k} = 31.13 \text{ ft-k}$$

$$M_D = \frac{4.50 \times 20^2}{8} = 225 \text{ ft-k} \quad (2700 \text{ in-k})$$

$$M_L = \frac{1.33 \times 20^2}{8} = 66.5 \text{ ft-k} \quad (798 \text{ in-k})$$

(i) Compute M_{cr}/M_a :

a) dead load

$$M_{cr}/M_a = 31.13/225 = 0.138$$

b) dead load plus live load

$$M_{cr}/M_a = 31.13/291.5 = 0.107$$

(ii) Compute the effective moment of inertia:

a) dead load

$$I_e = (0.138)^3 \times 2953 + [1 - (0.138)^3] 2430$$

$$I_e = 7.76 + 0.997 \times 2430 = 2431.4 \text{ in}^4$$

b) dead load plus live load

$$I_e = (.107)^3 \times 2953 + [1 - (.107)^3] 2430$$

$$I_e = 0.62 + 2427 = 2430.62 \text{ in}^4$$

(iii) Compute deflections for a simple span beam:

$$\Delta = 5L^2/M/48EI \quad (11)$$

$$\Delta = 5 \times (21.67 \times 12)^2 M / (48 \times 3798.6) I$$

$$\Delta = 338104M / 182332.8 I = 1.85 M/I$$

- the immediate live load deflection

$$\Delta_L = 1.85 \times 798 / 2430.62 = 0.607 \text{ in}$$

- the immediate dead load deflection

$$\Delta_D = 1.85 \times 2700 / 2431.4 = 2.054 \text{ in}$$

- the long-term deflection

$$\Delta_T = 2 \times 2.054 + 0.607 = 4.72 \text{ in}$$

(iv) The deflection limits (ACI Art.9.5.2.4)

$$L/180 = 1.43 \text{ in}$$

$$L/360 = 0.72 \text{ in}$$

$$L/480 = 0.54 \text{ in}$$

The slab band is not good for any of the deflection limits. Therefore, this alternative could not be applied in any circumstance.

4.1.3 Design alternative No. 3

The difference between design alternatives 2 and 3 is that in alternative No. 3, the slab band depth satisfies the minimum requirement for the deflection. Therefore, the slab band depth will have to be greater than that of the flat plate (see Fig. 3, p.28).

$$h_{\min} = \frac{g}{20} = \frac{21.67 \times 12}{20} = 13''$$

$$\text{use } \begin{array}{l} t = 22'' \\ b = 36'' \end{array}$$

(1) Loads:

$$\text{Dead load of the slab band} = \frac{36'' \times 22''}{144} \times 0.150 \times 1.4 = 1.16 \text{ k/ft}$$

$$\text{overhanging slab} = \frac{0.352 \times 200}{21.67} = 3.25 \text{ k/ft}$$

$$\text{flat plate} = \frac{.259 \times 19.33}{3} = 1.67 \text{ k/ft}$$

$$W_u = 6.08 \text{ k/ft}$$

$$M_u = \frac{6.08 \times 20^2}{8} = 304 \text{ ft-k}$$

$$F = \frac{36 \times 20.5^2}{12,000} = 1.26$$

$$K_u = \frac{304}{1.26} = 241 \rightarrow a_u = 3.60$$

$$\max K_u = 978$$

$$M_R = K_u b d^2 = .978 \times 36 \times 14.5^{2/12}$$

$$M_R = 617 \text{ ft-k} > M_u = 304 \text{ ft-k}$$

$$A_s = 304 / 3.60 \times 20.5 = 4.11 \text{ in}^2$$

use 5#8

(ii) Compute deflection:

$$\Delta = \frac{5\omega L^4}{384EI} \quad (12)$$

$$\omega = 6.08 \text{ k/ft} = 0.51 \text{ k/in}$$

$$L^4 = (21.67 \times 12)^4 = 4.573 \times 10^9$$

$$E = 547,000 \text{ k/ft}^2 = 3798.6 \text{ k/in}^2$$

$$I = \frac{36 \times 22^3}{12} = 31,944 \text{ in}^4$$

$$\Delta = \frac{5 \times 0.51 \times 4.573 \times 10^9}{384 \times 3798.6 \times 31944}$$

$$\Delta = \frac{11.66 \times 10^9}{4.659 \times 10^{10}} = 0.25$$

(iii) The deflection limits:

$$L/180 = 1.43 \text{ in} > \Delta$$

$$L/360 = 0.72 \text{ in} > \Delta$$

$$L/480 = 0.54 \text{ in} > \Delta$$

In this case, the slab band is good for flat roofs and floors not supporting or attached to nonstructural elements likely to be damaged by large deflections. In that respect, the deflection limits $L/180$ and $L/360$ are satisfied.

The windows and especially the wall of the round corner are made of glass which in our case, is a nonstructural element and therefore likely to be damaged by any considerable deflection. Although the wall and the windows do not rest directly on the slab band, the deflection limit $L/480$ has to be satisfied. In fact, $L/480 > \Delta$.

Design Alternative	Reinforcement	Additional Concrete	Cost of Formwork	Deflections
1	2.34 lbs/ft ²	22.32 cu-yd	\$1.50/ft ²	0.074 in
2	5.052 lbs/ft ²	0 cu-yd	\$1.25/ft ²	4.72 in
3	3.887 lbs/ft ²	2.91 cu-yd	\$1.50/ft ²	0.25 in

Table 5

Reinforcement per unit area

CHAPTER 5

CIRCULARLY CURVED HORIZONTAL BEAMS
WITH SYMMETRICAL UNIFORM LOADS

CHAPTER 5

CIRCULARLY CURVED HORIZONTAL BEAMS
WITH SYMMETRICAL UNIFORM LOADS⁷

Instead of using the column drop as a cantilever beam, we could use a circularly curved beam at every round corner as shown in Fig. 4. The circularly curved beam shall be extended beyond the closest columns to the round corner to the next columns as shown in Fig. 4. The circular beam starts at point A and ends at point B. ϕ_0 is a half-angle. The point C is the midspan of the curved beam. ϕ indicates the position of a concentrated load with respect to the center point C. (Fig. 4 is on p.41).

5.1 CONCENTRATED LOAD P AT ANY POSITION

The actual loading of the structure consists of two uniform loads:

- a) the precast concrete panels = 500 lbs/ft.
- b) the slab reaction (Dead and Live load) = 677 lbs/ft.

In order to demonstrate the use of a concentrated load on a curved beam, one can subdivide the beam into small segments each of which will correspond to a 15-degree or 20-degree interval. Then, the resultant of the uniform load on each segment is placed at the midpoint of the segment. Figure 5

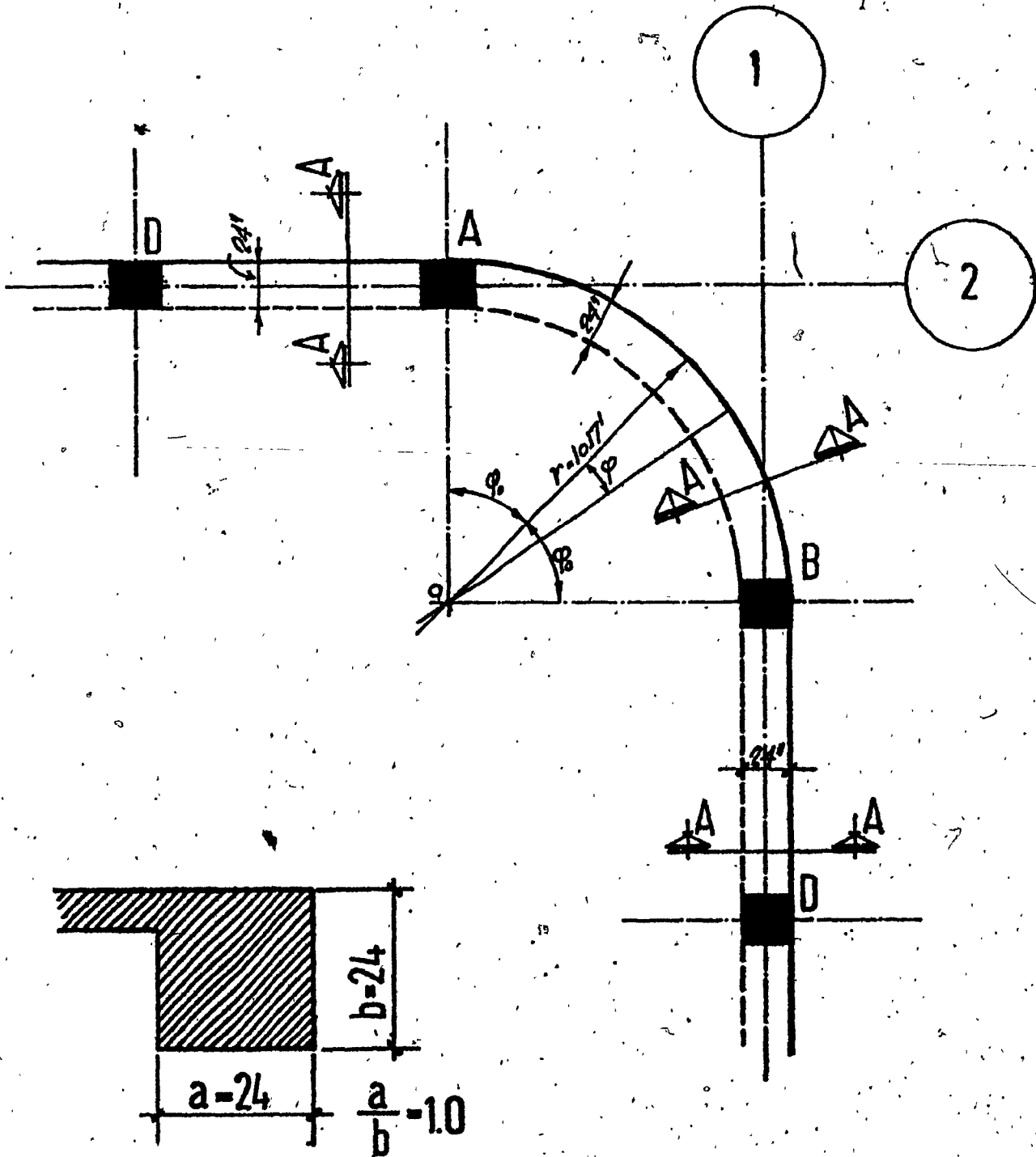

SECTION A-A

FIGURE 4

Layout and cross-section of the actual horizontal curved beam

shows the forces acting on a section of a curved beam. In Figure 5, the circular horizontal beam, is subject to a vertical load P at point K . X_1 , X_2 and X_3 are the bending moment, torsional moment and shearing force, respectively, at the midpoint. (Fig. 5 is on p.43).

The circularly curved horizontal beam with fixed ends is statically indeterminate to the third degree. That is, at any section in such a beam there exist three unknowns (as shown in Fig. 5) which must be determined for the solution of the force system. A convenient set of such unknowns consists of flexural and torsional moments, M_f and M_t , and a shear force, Q .

5.2 ANALYSIS WITH UNIFORM LOADS

At the midsection B of such a beam (see Fig. 6, p.44), we have, by symmetry, only the statically indeterminate flexural moment X of unknown magnitude. If we divide moment X into two moments X_t (torsional) and X_f (flexural), acting in planes respectively parallel to and perpendicular to any section S at an angle ϕ from the midpoint, we may write for these moments:

$$X_t = \sin\phi X \quad (13)$$

$$X_f = \cos\phi X \quad (14)$$

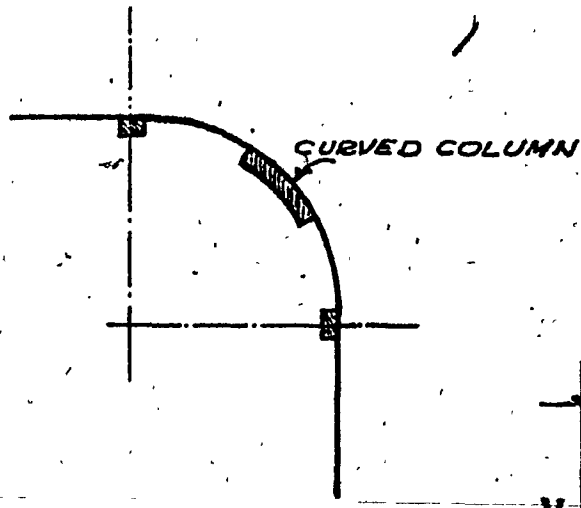

FIGURE 11
Curved cross-section
of a corner column

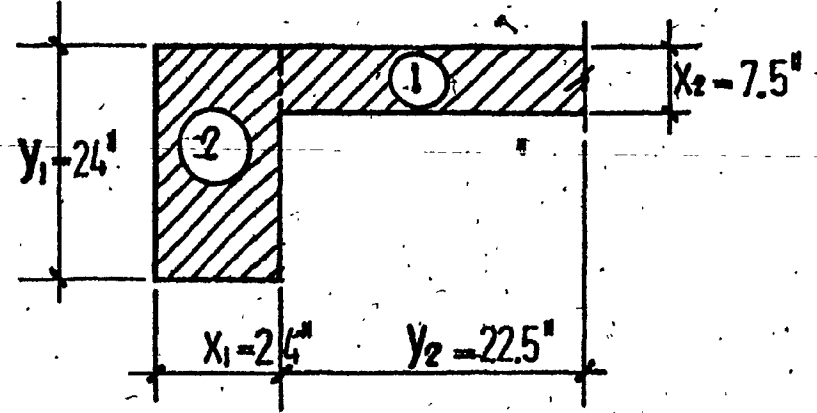

FIGURE 10
Curved beam cross-section

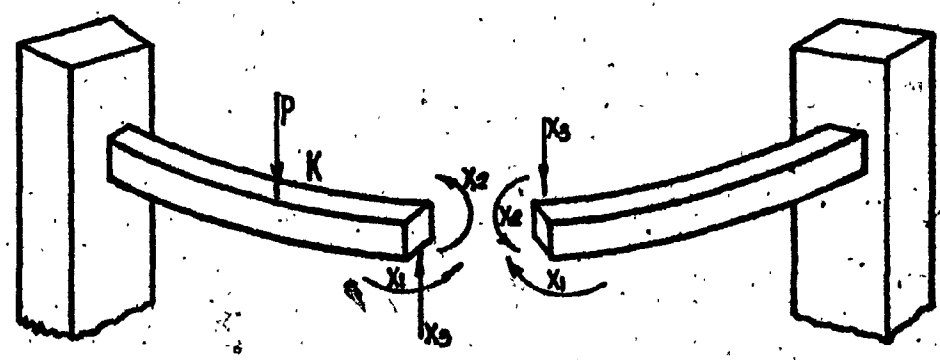

FIGURE 5
Forces acting on a curved beam

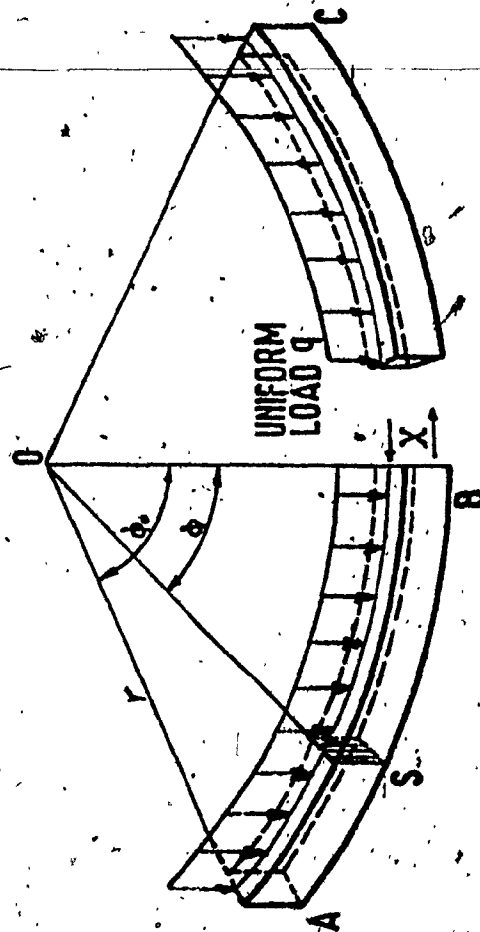

FIGURE 6

Horizontal curved beam with uniform load, q

The total flexural moment M_f acting at any section S will then be the flexural component of the midpoint moment X less the flexural moment M_{fg} due to the uniform load g distributed from the midpoint B to section S :

$$M_f = \cos\phi X - M_{fg} \quad (15)$$

The total distributed load from midpoint B to section S is :

$$Q = gr\phi \quad (16)$$

The flexural moment produced by this load may be computed by considering it to be concentrated at the centroid of the arc BC. Referring to Fig. 7 (p.46) for notation:

$$s = 2r\sin\phi\frac{1}{2} \quad (17)$$

$$b = r\phi \quad (18)$$

$$y = rs/b = 2r/\phi\sin\phi\frac{1}{2} \quad (19)$$

$$n = y\sin\phi\frac{1}{2} = 2r/\phi\sin^2\phi\frac{1}{2} = r/\phi(1 - \cos\phi) \quad (20)$$

$$M_{fg} = Qn = qr^2(1 - \cos\phi) \quad (21)$$

From Equations 15 and 21,

$$M_f = \cos\phi X - qr^2(1 - \cos\phi) \quad (22)$$

Similarly, M_t , the total torsional moment acting at section S, may be computed to be:

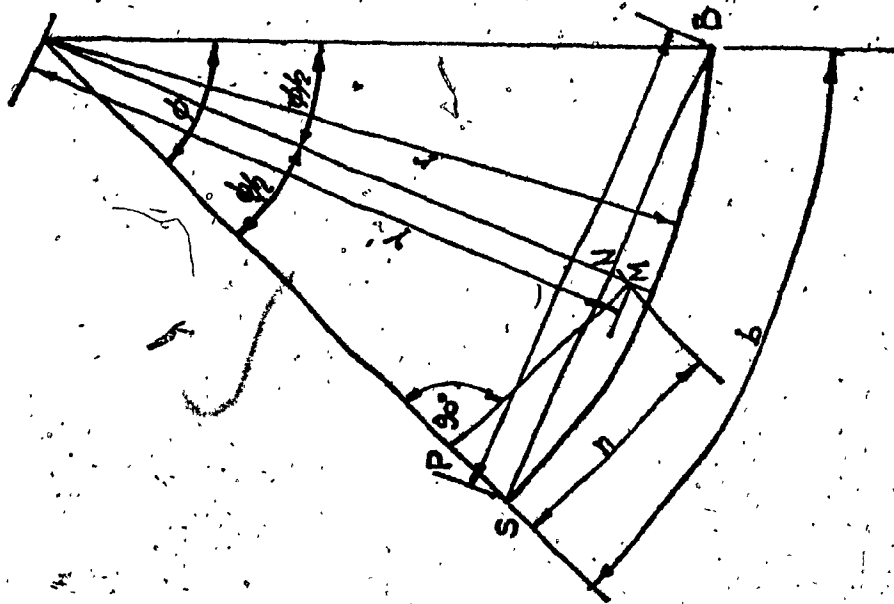

FIGURE 7
Geometry of the curved beam

$$M_t = \sin\phi X - M_{tq} = \sin\phi X - qr^2(\phi - \sin\phi) \quad (23)$$

where M_{tq} is the torsional moment due to uniform load q .

Castigliano's theorem⁷ may be stated as the distribution of forces in a loaded system is such that the work done in the system by the applied loads is a minimum. The work done⁷ by the flexural moment from the midspan to the end of the beam is :

$$U_f = \int_0^{\phi_0} \frac{(M_f)^2}{EI} r d\phi \quad (24)$$

The work done⁷ by the torsional moment in the same interval is :

$$U_t = \int_0^{\phi_0} \frac{(M_t)^2}{GJ'} r d\phi \quad (25)$$

where: J' = equivalent torsional second moment of area of a rectangular section computed by St. Venant's formula⁸:

$$J' = \frac{A^4}{40J} \quad (26)$$

$$J = \frac{ab^3 + ba^3}{12} \quad (\text{polar second moment of area}) \quad (27)$$

G = modulus of elasticity in shear.

E = modulus of elasticity in tension and compression.

I = moment of inertia of beam cross-section.

Setting up an expression for the minimum work by differentiating these expressions with respect to the unknown midspan flexural moment X , and setting the sum equal to zero, we obtain :

$$\int_0^{\phi_0} \frac{M_f}{EI} \times \frac{dM_f}{dX} \times r d\phi + \int_0^{\phi_0} \frac{M_t}{GJ} \times \frac{dM_t}{dX} \times r d\phi = 0 \quad (28)$$

Using Equations 22 and 23, and performing the indicated differentiations, we obtain :

$$\frac{1}{EI} \int_0^{\phi_0} [X \cos \phi - qr^2(1 - \cos \phi)] \cos \phi r d\phi + \frac{1}{GJ} \int_0^{\phi_0} [X \sin \phi - qr^2(\phi - \sin \phi)] \sin \phi r d\phi = 0 \quad (29)$$

Defining the ratio μ as $\mu = EI/GJ$ and taking E/G equal to 2.35, we obtain $\mu = 0.65(1 - b^2/a^2)$. Values of this ratio are calculated for various section ratios in Table 1 (p.49).

Performing the integrations of Equation 29, simplify-

a/ka	μ
a/a	1.3000
$a/1.1a$	1.4365
$a/1.2a$	1.5860
$a/1.3a$	1.7485
$a/1.4a$	1.9240
$a/1.5a$	2.1125
$a/1.6a$	2.3140
$a/1.7a$	2.5285
$a/1.8a$	2.7560
$a/1.9a$	2.9965
$a/2.0a$	3.2500

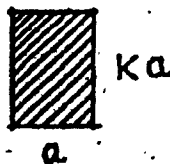

TABLE I'
Value of μ

ing, and making use of the above defined ratio μ , we obtain:

$$X = qr^2 \left[4 \left(\frac{\sin\phi(1+\mu) - \phi\cos\phi\mu}{2\phi(1+\mu) + \sin 2\phi(1-\mu)} \right) - 1 \right] \quad (30)$$

If we take $\phi_0 = 90^\circ = \frac{\pi}{2}$, Equation 30 reduces to

$$X = qr^2(4/\pi - 1) = 0.2749r^2 \quad (31)$$

For ϕ equal to 90° , X is therefore independent of μ .

For convenience, designate the bracketed-term of Equation 30 as N . Values of N for three values of μ and various half-angles ϕ are calculated⁷ in Table 2 (p.52).

Using expression N , Eqs. 22 and 23 can be simplified to:

$$M_f = qr^2 [\cos\phi(N+1) - 1] \quad (32)$$

$$M_t = qr^2 [\sin\phi(N+1) - \phi] \quad (33)$$

5.2.1 Example

Consider : $2\phi_0 = 90^\circ$,

$\phi_0 = 45^\circ = 0.7852$ radians

$\mu = 1.30$

From Table 2 (p.52) $X = 0.0924qr^2$.

The moments (Table 3, p.53) at the ends, by Equations

22 and 23:

$$M_f = 0.0924qr^2 \times 0.7071 - qr^2(1 - 0.7071) = 0.227qr^2$$

$$M_t = 0.0924qr^2 \times 0.7071 - qr^2(0.7852 - 0.7071) = -0.0128qr^2$$

By Equations 32 and 33 these moments are :

$$M_f = qr^2 [0.7071(0.0924 + 1) - 1] = -0.2276qr^2$$

$$M_t = qr^2 [0.7071(0.0924 + 1) - 0.7852] = -0.0128qr^2$$

Now, we can compute the moment because for a given structural problem we know the loading q and radius of the horizontal curved beam. Finally, in our case, the angle intersected by the proposed horizontal curved beam would be $2\phi_0 = 90^\circ$ or $\phi_0 = 45^\circ$. The center of the curve is at a distance $r = 10.17'$. This is self-explanatory on Fig. 4. Now, we can use the results of the above example since the angle ϕ_0 is the same, and the cross-section allows us ($a = b = 24"$, see Fig. 4) to use Table 2 (p.52) for $\mu = 1.3$.

$$M_f = 0.2276qr^2$$

$$M_t = -0.0128qr^2$$

where: M_f = flexural moment at the ends.

M_t = torsional moment at the ends.

q = uniform load = 1177 lbs/ft.

r = radius of curvature (from O to the center of the beam - see Fig. 4) = $10' - 2"$.

$X = q T^2 N$			
ϕ	$\mu = 1.30$	$\mu = 2.1125$	$\mu = 3.25$
15	0.0116	0.0116	0.0116
20	0.02	0.02	0.02
25	0.0308	0.0308	0.03
30	0.044	0.0432	0.042
35	0.0584	0.0572	0.0552
40	0.0748	0.0724	0.07
45	0.0924	0.0888	0.0852
50	0.1108	0.1064	0.102
55	0.1312	0.1256	0.12
60	0.1512	0.1448	0.1388
65	0.172	0.1652	0.1588
70	0.1928	0.1860	0.18
75	0.2136	0.2072	0.202
80	0.2344	0.2292	0.2248
85	0.2544	0.2510	0.2484
90	0.2735	0.2735	0.2735

TABLE 2⁷
Values of N

TABLE 3—VALUES OF M_r , M_c AND ϕ

ϕ	M_r	M_c	M_r	M_c	M_r	M_c	ϕ when $M_r = 0$
$\mu = 1.3$							
30	-0.0839 grs	+0.011 grs	-0.0015 grs	+0.00851 grs	-0.0015 grs	+0.00851 grs	38°12'
45	-0.1276 grs	+0.024 grs	-0.0128 grs	+0.02461 grs	-0.0128 grs	+0.02461 grs	40°48'
60	-0.1713 grs	+0.037 grs	-0.0190 grs	+0.03716 grs	-0.0190 grs	+0.03716 grs	50°51'
75	-0.2150 grs	+0.050 grs	-0.0253 grs	+0.05054 grs	-0.0253 grs	+0.05054 grs	58°31'
90	-0.2587 grs	+0.063 grs	-0.0316 grs	+0.06300 grs	-0.0316 grs	+0.06300 grs	65°00'
$\mu = 2.125$							
30	-0.0660 grs	+0.0372 grs	-0.0018 grs	+0.00851 grs	-0.0018 grs	+0.00851 grs	28°24'
45	-0.1097 grs	+0.0688 grs	-0.0153 grs	+0.02101 grs	-0.0153 grs	+0.02101 grs	40°00'
60	-0.1534 grs	+0.1004 grs	-0.0216 grs	+0.03351 grs	-0.0216 grs	+0.03351 grs	52°51'
75	-0.1971 grs	+0.1320 grs	-0.0279 grs	+0.04601 grs	-0.0279 grs	+0.04601 grs	58°11'
90	-0.2408 grs	+0.1636 grs	-0.0342 grs	+0.05851 grs	-0.0342 grs	+0.05851 grs	65°00'
$\mu = 3.25$							
30	-0.0777 grs	+0.0420 grs	-0.00214 grs	+0.00851 grs	-0.00214 grs	+0.00851 grs	28°10'
45	-0.1214 grs	+0.0736 grs	-0.0179 grs	+0.02101 grs	-0.0179 grs	+0.02101 grs	30°21'
60	-0.1651 grs	+0.1052 grs	-0.0242 grs	+0.03351 grs	-0.0242 grs	+0.03351 grs	51°58'
75	-0.2088 grs	+0.1368 grs	-0.0305 grs	+0.04601 grs	-0.0305 grs	+0.04601 grs	57°18'
90	-0.2525 grs	+0.1684 grs	-0.0368 grs	+0.05851 grs	-0.0368 grs	+0.05851 grs	65°00'

* M_r goes to zero at midspan, without reversal of sign.

TABLE 3⁷

Values of M_r , M_c and ϕ

The dead weight of the beam shall be included in the uniform loads q (see Fig. 4, p.41, for the beam section).

$$q = 1177 + \frac{24 \times 30}{144} \times 150 = 1927 \text{ lbs/ft.}$$

$$M_f = 0.2276 \times 1927 \times 10.17^2 = 45,362.4 \text{ ft-lbs.}$$

$$M_t = -0.0128 \times 1927 \times 10.17^2 = 2551.14 \text{ ft-lbs.}$$

The angles for the inflection points may be determined by equating Equations 32 and 33 to zero. Then the angle for the inflection point of flexural moment becomes :

$$\phi = \arccos \frac{1}{N+1} \quad (34)$$

By expanding⁷ the sine function in series form, the angle for the inflection point of torsional moment is approximately :

$$\phi, \text{ in radians} = \frac{6N}{N+1} \quad (35)$$

From Table 1, for $\frac{b}{a} = 1$ or $b = a$, use $\mu = 1.3$. By using Table 3 (p.53), we get the following angles for the inflection points :

$$a) \text{ for } \phi_0 = 45^\circ, \mu = 1.3, \text{ and } M_f = 0$$

$$\phi = 22^\circ 48'$$

Therefore, on each side of midpoint C on Fig. 8a (p.55) an angle of $22^\circ 48'$ will locate the inflection points B and D for flexural

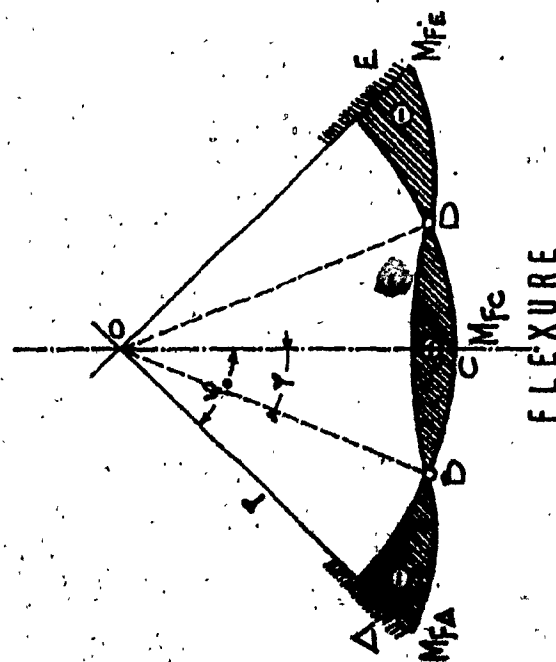
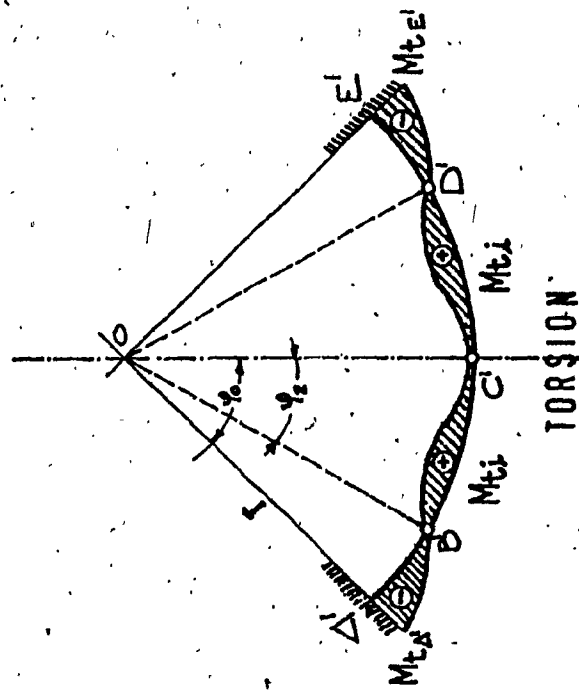

Figure 8b

Torsional moment diagram

Figure 8a

Bending moment diagram

FIGURE 8
Moment diagrams

moment.

b) for $\phi_0 = 45^\circ$, $\mu = 1.3$, and $M_t = 0$

$$\phi = 40^\circ 48'$$

An angle of $40^\circ 48'$ on each side of C' on Fig. 8b will locate the inflection points B', and D' for the torsional moment. But it should be noted that the torsional moment, M_t at mid-span goes to zero without reversal of sign (see Fig. 8b, p.55).

In order to have all pertinent values together, the computed moments are given in Table 4. For the computation

	FLEXURE		TORSION		
	M_{fe}	M_{fn}	M_{te}	M_{tm}	M_{ti}
	45.36 ft-k	18.42 ft-k	2.55 ft-k	0	5.1 ft-k
	70.31 ft-k	28.55 ft-k	3.95 ft-k	0	7.91 ft-k
Inflection points	$\phi = 22^\circ 48'$ from each side of the midpoint.		$\phi = 40^\circ 48'$ from each side of the midpoint including the midpoint.		

TABLE 4
Flexural and Torsional Moments

of these values, one has two alternatives:

a) use Tables 1, 2, and 3 for the values of μ , N , and M respectively.

b) use the equations mentioned in the preceding pages.

For all practical purposes, the use of the tables is more convenient for a practicing engineer.

The first values in the Table 4 are working moments, and the ultimate moments are shown on the second line.

In order to extend the analysis to beams DA, and BA, (p.41), a check should be made if the proposed section for the curved beam is adequate enough for the flexural and torsional moments, and for the combined shear and torsion stresses. If the section is good for the forces mentioned, there would be no need to extend the curved beam to the next column as shown on Fig. 4 (p.41). The extension of the curved beam would decrease the torsion effect noticeably.

When designing the flat slab, the curved beam shall enter into the computer input as a spandrel beam.

In short, the use of the curved beam would be more adequate than the use of the column drop panel as a cantilever. Furthermore, it is stated in article 13.1.6 of the Building Code, ACI-318-71, that no portion of a column capital or drop

panel shall be considered for structural purposes. This statement makes design alternative No. 1 less desirable.

5.2.2 Check of the section for the maximum ultimate moment in the Table 4 (p.56)

Assumed data :

$f'_c = 4000$ psi - specified compressive strength of concrete.

$f_y = 50,000$ psi - specified yield strength of steel.

From Table 4, max $M_u = 70.31$ ft-k

$$F = \frac{bd^2}{12,000} = \frac{24 \times 22.5^2}{12,000} = 1.013$$

where: $F =$ a flexural coefficient.

$b =$ width of the compression face.

$d =$ distance from extreme compression fiber to centroid of tension reinforcement.

$$K_u = \frac{M_u}{F} = \frac{70.31}{1.013} = 69 < \text{mini } K_u = 175$$

where: $K_u =$ strength coefficient of resistance.

$M_u =$ ultimate flexural moment.

The ratio of nonprestressed tension reinforcement

$$\rho = A_s / bd$$

where A_s area of tension reinforcement.

The minimum ratio $\rho = 200/f_y$

$$\min \rho = \frac{200}{50,000} = 0.0040$$

and this minimum ratio corresponds to $K_u = 175$.

The actual $K_u = 69 < \min K_u = 175$, therefore, the section is adequate and could be reduced if desired.

5.3 COMBINED TORSION AND SHEAR

5.3.1 Discussion

Design provisions for torsion are analogous to those for shear. First, the nominal ultimate torsional stress, v_{tu} , acting on the member cross-section is determined. Second, a nominal torsional stress that may be carried by the concrete, v_{tc} , is computed, taking into account any shear stress acting concurrently on the section. If v_{tu} is greater than v_{tc} , torsion reinforcement may be provided in the member to carry the difference, or the size of the member increased to make v_{tu} less than v_{tc} . If torsion reinforcement is used, it must consist of both closed stirrups and longitudinal bars.

The Code requires that nonprestressed members be designed for torsion only when this torsion produces a nominal torsion stress, v_{tu} , greater than $1.5\sqrt{f'_c}$. This is about 25 percent of the pure torsional strength of a member without reinforcement.

The nominal ultimate torsional stress is computed from :

$$v_{tu} = \frac{3T_u}{\phi \Sigma x^2 y}$$

where T_u = design torsional moment
 ϕ = capacity reduction factor 0.85
 x = shorter side of cross-section
 y = longer side of cross-section

For most T and L-sections, the component rectangles will be the web extending through the overall depth of the section plus the outstanding flanges. However, the outstanding flange width shall not be taken equal to more than three times the flange thickness¹.

The torsion stress which may be assumed to be carried by the concrete when a beam is subjected to combined torsion and shear is given by¹ :

$$v_{tc} = \frac{2.4 \sqrt{f'_c}}{\sqrt{1 + (1.2v_u/v_{tu})^2}}$$

where v_{tc} = nominal permissible torsion stress
 f'_c = specified compressive strength of concrete
 v_u = nominal total design shear stress
 v_{tu} = nominal total design torsion stress

To ensure that yielding will occur, the amount of reinforcement is limited, indirectly, by an upper limit on the design torsion and shear stresses given by:

$$v_u = \frac{12 \sqrt{f'_c}}{\sqrt{1 + (1.2v_u/v_{tu})^2}}$$

This relationship¹ limits v_u to $10 \sqrt{f'_c}$ when v_{tu} is zero and to $12 \sqrt{f'_c}$ when v_{tu} is zero.

Closed stirrups are required to carry the difference between v_{tu} and v_{tc} . It is more economical to use the same type of closed stirrups for both torsion and shear requirements.

When the design torsion exceeds that which can be carried by the concrete, closed stirrups shall be provided as

determined from¹ :

$$A_t = \frac{(v_{tu} - v_{tc}) s E x^2 y}{3 \alpha_t x_1 y_1 f_y}$$

where A_t = area of one leg of closed stirrup resisting torsion within a distance s , in².

s = shear or torsion reinforcement spacing.

α_t = a coefficient which is a function of y_1/x_1 .

x_1 = shorter center-to-center dimension of a closed rectangular stirrup.

y_1 = longer center-to-center dimension of a rectangular stirrup.

f_y = specified yield strength of nonprestressed reinforcement.

In the "truss analogy", the main flexural reinforcement of a beam serves as the tension chord of a truss in which the diagonals are provided by the concrete posts in compression and web reinforcement links in tension. When torsion is present, all sides of the member must have a tension chord, because the torsion can cause diagonal cracking on any face. The amount of longitudinal reinforcement required is given by :

$$A_s^t = 2A_t \frac{x_1 + y_1}{s}$$

The cross-section of our actual curved beam is shown in Fig. 10 (p.43).

5.3.2 Computation of the actual torsion and shear

Assumed data:

$$f'_c = 4000 \text{ lbs/in}^2$$

$$f_y = 50,000 \text{ lbs/in}^2$$

$$\phi = 0.85 \text{ (capacity reduction factor)}$$

$$v_{tu} = 1.5 \sqrt{f'_c} = 1.5 \sqrt{4000} = 95 \text{ psi.}$$

From Table 4, $M_{te} = T_u = 3.95 \approx 4 \text{ ft-k.}$

M_{te} is the maximum torsional moment at the end of the curved beam.

From Fig. 10,

$$\Sigma x^2 y = 24^2 \times 24 + 7.5^2 \times 22.5 = 15,100 \text{ in}^3$$

$$v_{tu} = \frac{3T_u}{\phi \Sigma x^2 y} = \frac{3 \times 4 \times 12,000}{0.85 \times 15,100} = 11.22 \text{ psi.}$$

$$v_{tu} = 11.22 \text{ psi} < 95 \text{ psi.}$$

Therefore torsion must not be considered. From Fig. 4 (p.41), the total shear at the end of the curved beam is:

$$V_u = q r \phi_0$$

where q = uniform loads on the curved beam

r = radius of the curve

ϕ_0 = half angle 45°

$$V_u = 1824.4 \times 10.17 \times (45 \times 0.0175) = 14,611 \text{ lbs.}$$

$$d = 24" - 2" = 22"$$

Compute the ultimate shear stress :

$$v_u = \frac{V_u}{\phi b d}$$

where V_u = maximum total shear at the face of the support

b = width of compression face of member

d = distance from compression fiber to centroid of tension reinforcement

ϕ = capacity reduction factor = 0.85

$$v_u = \frac{14,611}{0.85 \times 24 \times 22} = 32.6 \text{ psi} < 2 \sqrt{f'_c} \quad \text{O.K.}$$

Since the torsion reinforcement is not required, and the section is adequate without web reinforcement, the assumed beam section could be reduced if desired. Nevertheless, a minimum horizontal web reinforcement should be provided, #4@12", and a minimum vertical stirrup reinforcement of #4@11". The stirrups shall be closed.

Since the curved beam is adequate for the flexural and torsional moments, as well as, for the shear and torsional stresses, one can say that it is not essential to extend the curved beam as shown on Fig. 4. For a large torsional moment, the extension of the curved beam would be desirable, and the use of the grid program would be essential.

CHAPTER 6

CONCLUSIONS

CHAPTER 6
CONCLUSIONS

6.1 DESIGN ALTERNATIVE NO. 1

My choice was design alternative No. 1. The drop around any column was not desirable for an easy removal of the steel formwork of the flat plate. But in design alternative No. 1, the steel formwork can be lowered to its maximum of 2.5" and removed in the direction parallel to the direction of the length of the drop.

The reinforcing steel per area is 2.34 lbs/ft^2 . This quantity includes the additional steel due to the deflection of the cantilever used as an elastic support of the last span of the perpendicular column strip. It should be noted that this steel quantity is 2.16 times smaller than that of design alternative No. 2, and 1.66 times smaller than that of design alternative No. 3.

Although it is not possible to make accurate predictions about deflections, one of the main reasons design No. 1 was chosen was that the cantilever deflection is 0.074 in. which is much less than calculated by using the other two design alternatives. In fact, the deflection is the main concern because the round corner of the slab is attached to

supporting nonstructural elements which are likely to be damaged by any considerable deflections.

Design No. 1 has some disadvantages. In fact, there is an additional concrete quantity of 22.32 cu.yds. per corner or 178.56 cu.yds. per floor. This extra concrete quantity is due to the drop around the columns at the round corners. Also, in addition to the extra concrete quantity, there is an additional reaction of 6.05 K per column (only the columns having a drop at the round corners). This reaction increases the load on the footing by an amount of 181.5 K. Of course, it also increases the steel or the size of the column.

The cost of the formwork is \$1.50 per square foot. It should be noted that the cost varies often.

In appendix B for the computer input and output, one can see that the cantilever beam is in reality, a column drop, and in fact, it was entered into the computer as a drop. This is wrong, and the drop should not be treated as a beam. On the other hand, if the drop is accepted as a cantilever beam, it should be extended to the next column.

It is clearly stated in article 13.1.16 (ACI-318-71) that no portion of a column capital or drop shall be considered for structural purposes.

Although this design alternative was selected, I would personally recommend the use of a curved beam as shown on Fig. 4 (p.41). Furthermore, I would recommend a finite element analysis or the use of a grid program.

The use of the finite element, and a grid computer program would be necessary if the cantilever slab was of a considerable size. Also, a better solution would be to have a column at the round corners. This column will have a round shape. In reality this column could serve as a wall depending on the size. Such a column is shown in Fig. 11 (p.43). Using this type of column at the corner there would be no need for a special analysis and there would not be any problem as far as the deflection is concerned.

6.2 DESIGN ALTERNATIVE NO. 2

This alternative is rejected because of the high deflection of the slab band:

- (i) - immediate live load deflection

$$\Delta_L = 0.607 \text{ in.}$$

- (ii) - immediate dead load deflection

$$\Delta_D = 2.054 \text{ in.}$$

- (iii) - long-term deflection

$$\Delta_T = 4.72 \text{ in.}$$

(iv) - the Code¹ deflection limit: $L/480$

max $\Delta = 0.54 \text{ in.} < \text{all actual deflections}$

Also, design No. 2 has a larger reinforcement quantity per area: 5.052 lbs/ft^2 .

This alternative could have two advantages:

(i) - there is no drop around the columns at the round corners. Therefore, there is no additional concrete quantity.

(ii) - the cost of the formwork is \$1.25 per sq.ft.

6.3 DESIGN ALTERNATIVE NO. 3

This alternative has one main disadvantage which would be the use of standard formwork instead of the steel formwork commonly used in construction of the flat plate floors. Flat slabs are thin members; they are not economical if one considers the steel, but they are economical in their formwork. Since formwork represents over half the cost of reinforced concrete, the economy of the formwork often means an overall economy.

The deflection of the beam is 0.25 in. It satisfies

the Code deflection limit of $L/480$. But the deflection of design No. 1 is 0.074 in., which is 3.39 times less than that of design No. 3. Again, it should be noted that the main concern is the deflection. For that reason, alternative No. 3 was rejected.

Design No. 3 has other disadvantages.

- (i) - its reinforcement quantity per area is 3.887 lbs/ft² which is 1.66 times that of design No. 1.
- (ii) - it has an additional concrete quantity (due to beam) of 23.28 cu.yds. per floor.
- (iii) - the cost of the formwork is \$1.50 per sq.ft. Without the beam, the cost could be \$0.25 less per sq.ft.

REFERENCES

REFERENCES

- [1] Building Code Requirements for Reinforced Concrete, ACI-318-71.
- [2] Hognestad, E., "Yield Line Theory for the Ultimate Flexural Strength of Reinforced Concrete Slabs", J. ACI, (March 1953), pp.637-654.
- [3] National Building Code, 1970, Supplement No. 4.
- [4] Nichols, J.R., "Statistical Limitations Upon the Steel Requirement in Reinforced Concrete Flat Slab Floors", Trans. ASCE, Vol. 77, (1914), pp.1670-1736.
- [5] Reinforced Concrete Fundamentals, Second Ed. (1965), by Phil M. Ferguson, John Wiley & Sons, Inc.
- [6] Design of Concrete Structures, Seventh Ed. (1964), by G. Winter, MacGraw-Hill Book Co.
- [7] Schulz, M. and Chedrani, M., "Circularly Curved Horizontal Beams with Symmetrical Uniform Loads", Journal of American Concrete Institute, (October 1963), pp.1033-1040.
- [8] Theory of Elasticity. Third Ed. (1970), by S.P. Timoshenko, McGraw-Hill Book Co.
- [9] Structural Mechanics, by Samuel T. Carpenter, John Wiley & Sons, Inc.
- [10] Spyropoulos, P.J., "Circularly Curved Beams Transversely Loaded", Journal of American Concrete Institute, (October 1963), pp.1457-1468.

APPENDIX "A"
DRAWINGS AND SCHEDULES

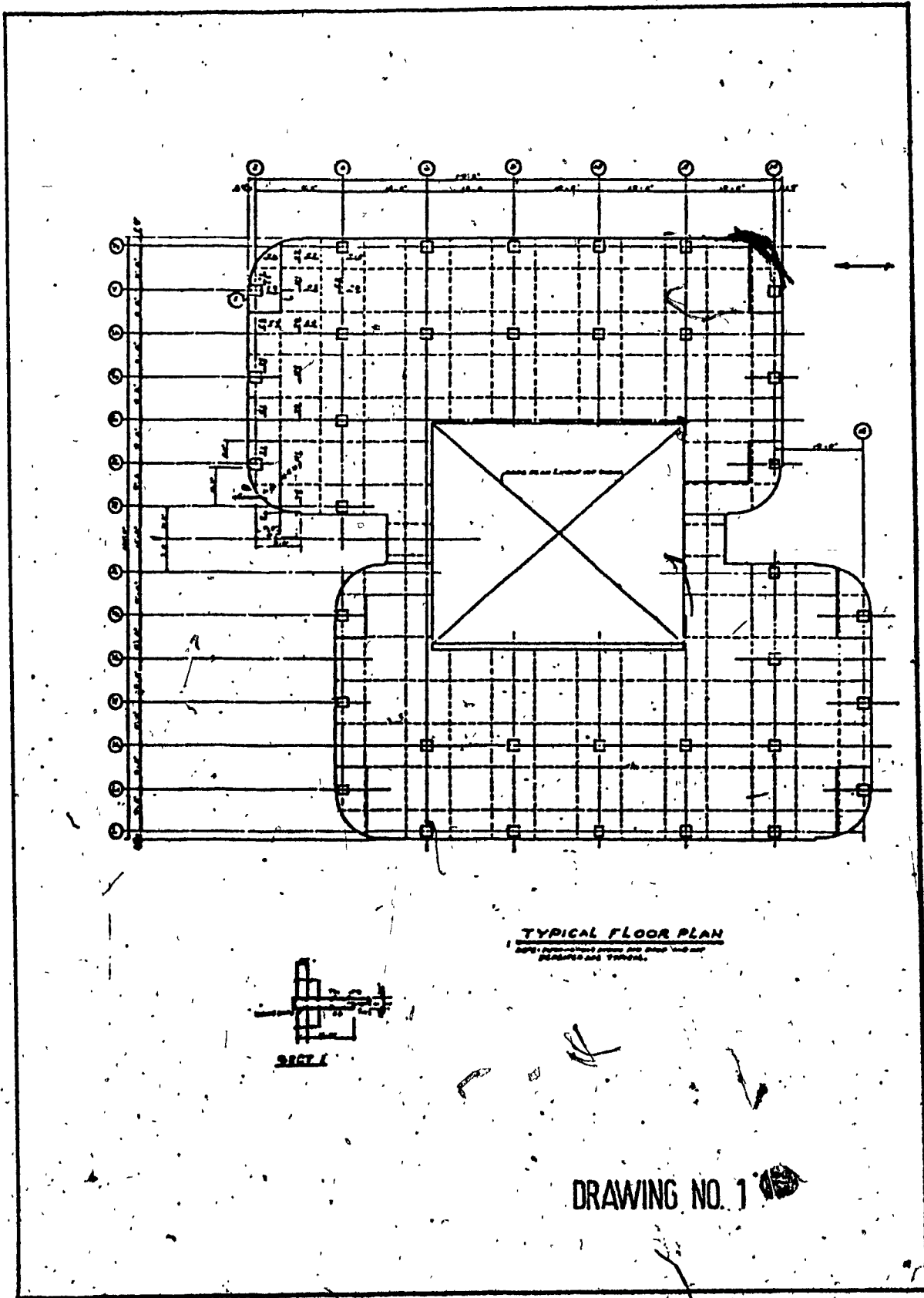

TYPICAL FLOOR PLAN

1. SHOW APPROXIMATE POSITION AND SIZE FOR THE
2. SHOW APPROXIMATE POSITION AND SIZE FOR
3. SHOW APPROXIMATE POSITION AND SIZE FOR

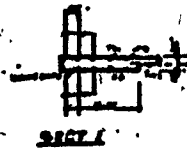

DRAWING NO. 1

1ST LAYER E-W DIRECTION BOT. BARS

MARK	QTY	REINFC.	£	£	REMARKS
C1	1	4-4167	8"	_____	
		3-41910	3"	_____	
C2	1	4-4167		_____ 3"	
		3-41910		_____ 6"	
C5	1	6-5 VAR.L.	7"	_____	ADD 1/2 AT BOT. DROP EDGE
C6	1	9-4199			
M1	2	9-41910		_____	
M2	1	9-4290		_____	

REINFORCING SCHEDULE 1
CORNER REINFORCEMENT

2ND LAYER N-S DIRECTION BOT BARS

MARK	QTY.	REINFC	⊘	⊘	REMARKS
C3	1	8-4/59	6"	_____	
C4	1	9-4213	_____	8"	
MB	1	9-4/59	_____		

REINFORCING SCHEDULE 2
CORNER REINFORCEMENT

3RD LAYER N-S DIRECTION TOP BARS					
MARK	QTY	REINFC	£	£	REMARKS
T8	1	9-4099	—	—	
T9	1	11-5109	—	1.5'	
		5-5109	—	1.5'	OVER COL. ONLY
T10	1	4-6110	—	—	
		5-6076	—	—	
T11	1	6-5089	—	1.5'	
T12	1	9-4073	—	1.5'	

REINFORCING SCHEDULE 3
CORNER REINFORCEMENT

4TH LAYER E-W DIRECTION TOP BARS

MARK	QTY	REINFC.	⊥	⊥	REMARKS
T1	1	9-6190	12"	8'-4"	
		8-8174	12"	6'-8"	
T2	1	4-5116	6'-9"		
		3-5078	8'-10"		
T3	1	9-6190		8'-4" 7/8"	
		8-6174		6'-8" 7/8"	
T4	1	9-4260	6" 1/8"		
T5	1	9-41910	8"		
T6	1	9-4099			
T7	1	9-4216		1'-8" 1/2"	

REINFORCING SCHEDULE 4
CORNER REINFORCEMENT

APPENDIX "B"
COMPUTER INPUT AND OUTPUT

COMPTON DATA

1-084843

LAVIN INC.
COSTA MEX.



615 RUE BELMONT MONTREAL

COSTA INC.

PCA PROGRAM
FOR
FLY PLATE SUB ELEM CA STRUDT DROP PANEL
WAFLE AND
DESIGN

SLAB CARD
(only one)

Number of spans	Concrete weight (lb/ft ³)	Slab thickness (in.)	Slab height above base (ft)	Slab height below base (ft)	Ratio of slab depth	Span Numbers	Output section	Vertical
2	150	7.5	11.0	11.0	1.5			

WAFPLE SLAB CARD
(only for waffle slabs)

Slab species (in.)	Slab depth (in.)	Top Slab thickness (in.)	Slab width at bottom (in.)	Slab width at top (in.)	Slab height below base (ft)	Ratio of slab depth	Span Numbers	Output section	Vertical

SLAB CARDS
..... (up to 12)

Span length (ft)	Live load (lb/ft ²)	Superimposed D.L. (lb/ft ²)	L.L. (lb/ft)	Partial Loadings						Support	
				C1 (ft)	C2 (ft)	D.L. (lb/ft)	Z1 (ft)	C2 (ft)	C2 (ft)		
11	1	7.5				5.75	11.0				
11	3	7.5				5.75	11.0				
11	5	7.5				5.75	11.0				

COLUMN CARDS
(up to 12)

Column Size above slab (in.)	Column Size below slab (in.)	Slab width (ft)	Slab thickness (in.)	Free Panels				Endspan Center				Support		
				width (ft)	height L (ft)	height M (ft)	height N (ft)	width (ft)	height L (ft)	height M (ft)	height N (ft)			
14	14	11.0	7.5	11.0	11.0	11.0	11.0	11.0	11.0	11.0	11.0	11.0	11.0	11.0
14	14	11.0	7.5	11.0	11.0	11.0	11.0	11.0	11.0	11.0	11.0	11.0	11.0	11.0
14	14	11.0	7.5	11.0	11.0	11.0	11.0	11.0	11.0	11.0	11.0	11.0	11.0	11.0

CERTIFICATE CARDS
(Always 2)

SPECIFICATIONS CARDS
(only 1)

~~END LOGS~~
~~LOGS CARDS~~
(only 1)

~~RING LOG CARD~~
~~Use only for Rings or 4~~
~~(only 1)~~

CARTS

Design method	Type of concrete	Yield strength (ksi)	Tensile and yield (ksi)	Compressive strength (ksi)	Spacer Eggs				Sensitivity of design certification		
					T (in.)	B (in.)	F (in.)	D (in.)			
12	0	0	0	0	0	0	0	0	0	0	0
13	0	0	0	0	0	0	0	0	0	0	0
14	0	0	0	0	0	0	0	0	0	0	0
15	0	0	0	0	0	0	0	0	0	0	0
16	0	0	0	0	0	0	0	0	0	0	0
17	0	0	0	0	0	0	0	0	0	0	0
18	0	0	0	0	0	0	0	0	0	0	0
19	0	0	0	0	0	0	0	0	0	0	0
20	0	0	0	0	0	0	0	0	0	0	0
21	0	0	0	0	0	0	0	0	0	0	0
22	0	0	0	0	0	0	0	0	0	0	0
23	0	0	0	0	0	0	0	0	0	0	0
24	0	0	0	0	0	0	0	0	0	0	0
25	0	0	0	0	0	0	0	0	0	0	0
26	0	0	0	0	0	0	0	0	0	0	0
27	0	0	0	0	0	0	0	0	0	0	0
28	0	0	0	0	0	0	0	0	0	0	0
29	0	0	0	0	0	0	0	0	0	0	0
30	0	0	0	0	0	0	0	0	0	0	0
31	0	0	0	0	0	0	0	0	0	0	0
32	0	0	0	0	0	0	0	0	0	0	0
33	0	0	0	0	0	0	0	0	0	0	0
34	0	0	0	0	0	0	0	0	0	0	0
35	0	0	0	0	0	0	0	0	0	0	0
36	0	0	0	0	0	0	0	0	0	0	0
37	0	0	0	0	0	0	0	0	0	0	0
38	0	0	0	0	0	0	0	0	0	0	0
39	0	0	0	0	0	0	0	0	0	0	0
40	0	0	0	0	0	0	0	0	0	0	0
41	0	0	0	0	0	0	0	0	0	0	0
42	0	0	0	0	0	0	0	0	0	0	0
43	0	0	0	0	0	0	0	0	0	0	0
44	0	0	0	0	0	0	0	0	0	0	0
45	0	0	0	0	0	0	0	0	0	0	0
46	0	0	0	0	0	0	0	0	0	0	0
47	0	0	0	0	0	0	0	0	0	0	0
48	0	0	0	0	0	0	0	0	0	0	0
49	0	0	0	0	0	0	0	0	0	0	0
50	0	0	0	0	0	0	0	0	0	0	0
51	0	0	0	0	0	0	0	0	0	0	0
52	0	0	0	0	0	0	0	0	0	0	0
53	0	0	0	0	0	0	0	0	0	0	0
54	0	0	0	0	0	0	0	0	0	0	0
55	0	0	0	0	0	0	0	0	0	0	0
56	0	0	0	0	0	0	0	0	0	0	0
57	0	0	0	0	0	0	0	0	0	0	0
58	0	0	0	0	0	0	0	0	0	0	0
59	0	0	0	0	0	0	0	0	0	0	0
60	0	0	0	0	0	0	0	0	0	0	0
61	0	0	0	0	0	0	0	0	0	0	0
62	0	0	0	0	0	0	0	0	0	0	0
63	0	0	0	0	0	0	0	0	0	0	0
64	0	0	0	0	0	0	0	0	0	0	0
65	0	0	0	0	0	0	0	0	0	0	0
66	0	0	0	0	0	0	0	0	0	0	0
67	0	0	0	0	0	0	0	0	0	0	0
68	0	0	0	0	0	0	0	0	0	0	0
69	0	0	0	0	0	0	0	0	0	0	0
70	0	0	0	0	0	0	0	0	0	0	0
71	0	0	0	0	0	0	0	0	0	0	0
72	0	0	0	0	0	0	0	0	0	0	0
73	0	0	0	0	0	0	0	0	0	0	0
74	0	0	0	0	0	0	0	0	0	0	0
75	0	0	0	0	0	0	0	0	0	0	0
76	0	0	0	0	0	0	0	0	0	0	0
77	0	0	0	0	0	0	0	0	0	0	0
78	0	0	0	0	0	0	0	0	0	0	0
79	0	0	0	0	0	0	0	0	0	0	0
80	0	0	0	0	0	0	0	0	0	0	0
81	0	0	0	0	0	0	0	0	0	0	0
82	0	0	0	0	0	0	0	0	0	0	0
83	0	0	0	0	0	0	0	0	0	0	0
84	0	0	0	0	0	0	0	0	0	0	0
85	0	0	0	0	0	0	0	0	0	0	0
86	0	0	0	0	0	0	0	0	0	0	0
87	0	0	0	0	0	0	0	0	0	0	0
88	0	0	0	0	0	0	0	0	0	0	0
89	0	0	0	0	0	0	0	0	0	0	0
90	0	0	0	0	0	0	0	0	0	0	0
91	0	0	0	0	0	0	0	0	0	0	0
92	0	0	0	0	0	0	0	0	0	0	0
93	0	0	0	0	0	0	0	0	0	0	0
94	0	0	0	0	0	0	0	0	0	0	0
95	0	0	0	0	0	0	0	0	0	0	0
96	0	0	0	0	0	0	0	0	0	0	0
97	0	0	0	0	0	0	0	0	0	0	0
98	0	0	0	0	0	0	0	0	0	0	0
99	0	0	0	0	0	0	0	0	0	0	0
100	0	0	0	0	0	0	0	0	0	0	0
Total load from above floors (lbs)					Total load at this floor (lbs)						
1					1					1	
2					2					2	
3					3					3	
4					4					4	
5					5					5	
6					6					6	
7					7					7	
8					8					8	
9					9					9	
10					10					10	
11					11					11	
12					12					12	
13					13					13	
14					14					14	
15					15					15	
16					16					16	
17					17					17	
18					18					18	
19					19					19	
20					20					20	
21					21					21	
22					22					22	
23					23					23	
24					24					24	
25					25					25	
26					26					26	
27					27					27	
28					28					28	
29					29					29	
30					30					30	
31					31					31	
32					32					32	
33					33					33	
34					34					34	
35					35					35	
36					36					36	
37					37					37	
38					38					38	
39					39					39	
40					40					40	
41					41					41	
42					42					42	
43					43					43	
44					44					44	
45					45					45	
46					46					46	
47					47					47	
48					48					48	
49					49					49	
50					50					50	
51					51					51	
52					52					52	
53					53					53	
54					54					54	
55					55					55	
56					56					56	
57					57					57	
58					58					58	
59					59					59	
60					60					60	
61					61					61	
62					62					62	
63					63					63	
64					64					64	
65					65					65	
66					66					66	
67					67					67	
68					68					68	
69					69					69	
70					70					70	
71					71					71	
72					72					72	
73					73					73	
74					74					74	
75					75					75	
76					76					76	
77					77					77	
78					78					78	
79					79					79	
80					80					80	
81					81					81	
82					82					82	
83					83					83	
84					84					84	
85					85					85	
86					86					86	
87					87					87	
88					88					88	
89					89					89	
90					90					90	
91					91					91	
92					92					92	

INPUT DATA ARE AS FOLLOWS

NO. OF SPANS = 2.0 REIN. YIELD STRENGTH = 50000.0 CONC. STRENGTH = 4000.0
 REIN. SPL. RATIO = 1.00

SPAN NO.	LENGTH (FT)	LIVE LD. (PSF)	SUPERST. (PSF)	PARTIAL LL. (FT)	C1 (FT)	C2 (FT)	PARTIAL DL. (FT)	C1 (FT)	C2 (FT)
1	19.3	56.9	76.5	0.0	0.0	0.0	570.0	0.0	5.0
2	17.3	50.0	76.0	0.0	0.0	0.0	570.0	14.3	5.0

EAST/EASTWEST AT END LIVE LOAD SUPER. DL LINE LL LINE DL SPAN/REIN. BEANS IF ANY
 END LENGTH (FT) (FT) (PSF) (PSF) (IN) (IN) (IN) (IN) DEPTH (IN) ECCENTRICITY
 LEFT 9.7 11.4 32.8 76.0 0.0 0.0 300.0 8.0 0.0 0.0
 RIGHT 9.7 11.4 32.8 76.0 0.0 0.0 300.0 8.0 0.0 0.0

CAUSE & L.D. DIRECTION: * COLUMN ABOVE SLAB * PERPENDICULAR * IN DIRECTION * PERPENDICULAR * AT COL. LINE *
 NUMBER OF SPANS: 2 * SPAN LENGTH: 19.3 (FT) * SPAN LENGTH: 17.3 (FT) * SPAN LENGTH: 19.3 (FT) * SPAN LENGTH: 17.3 (FT)
 1 19.3 17.3 19.3 17.3
 2 17.3 19.3 17.3 19.3

STORY HEIGHT ABOVE (FT) = 11.0 STORY HEIGHT BELOW (FT) = 11.0
 CONC. SLAB THICKNESS (IN) = 13.0 CONC. SLAB THICKNESS (IN) = 7.5
 DESIGN. BY: ATILALTE STRUCTURAL ENGINEERING

SPAN NO.	LENGTH (FT)	LIVE LD. (PSF)	SUPERST. (PSF)	PARTIAL LL. (FT)	C1 (FT)	C2 (FT)	PARTIAL DL. (FT)	C1 (FT)	C2 (FT)	SPAN/REIN. BEANS IF ANY	DEPTH (IN)	ECCENTRICITY
1	19.3	56.9	76.5	0.0	0.0	0.0	570.0	0.0	5.0			
2	17.3	50.0	76.0	0.0	0.0	0.0	570.0	14.3	5.0			

4/1/59

DESIGN PART

SHEAR STRESSES

ALLOWABLE SHEAR STRESS FOR NORMAL-WEIGHT CONCRETE--- TWO WAY SLAB SHEAR STRESS= 232.9 (PSI)
 BEAM OR JOIST SHEAR STRESS= 124.4 (PSI)

COL. NO.	WITHOUT TRANSFER OF MOMENT				WITH TRANSFER OF MOMENT				CRIT. SECT. DIM. (IN)	CRIT. SECT. DIM. (FT- $\frac{1}{2}$)	FLEX. CAP. (FT-K)
	POS. STRESS (PSI)	NEG. STRESS (PSI)	VERT. REACT. (KIPS)	VERT. REACT. (FT-K)	POS. STRESS (PSI)	NEG. STRESS (PSI)	VERT. REACT. (KIPS)	VERT. REACT. (FT-K)			
1	37.6	4	99.8	19.1	69.6	40.4	4	66.7	40.4	2.12	94.74
2	37.8	4	99.9	19.2	69.9	40.6	4	67.1	40.8	2.12	94.74

PRINT-OUT OF STATICS

COLUMN PATTERNS NO.1	SLAB	PATIO NO.2 (FT-KIP)		PATIO NO.3		PATIO NO.4	
		LEFT	RIGHT	LEFT	RIGHT	LEFT	RIGHT
1	LEFT					-230.0473	-208.9823
	RIGHT					-17.9133	-82.4848
						-214.6811	-282.6953
COLUMN MOMENTS (FT-KIP)							
1	ABOVE	BELOW	ABOVE	BELOW	ABOVE	BELOW	
2	LEFT	RIGHT	SHEAR FORCES (KIP)	LEFT	RIGHT	LEFT	RIGHT
3	LEFT	RIGHT		LEFT	RIGHT		

DESIGN FOR CLOSURE (FOR THE DEFLECTOR LAYER) REINFORCEMENT LAYER FROM BOTTOM.1

POSITIVE REINFORCEMENT	NEGATIVE REINFORCEMENT		CALC. RES. COEFFICIENT		STEEL AREA		INFLX. PT. LEFT GOV. PT.		INFLX. PT. RIGHT GOV. PT.		MOM. BY SEC. BY		
	MAX. POS. X1	AT POINT LEFT	GOV. PART.	COEFF. (LET-X1)	COEFF. (LET-X1)	COEFF. (LET-X1)	COEFF. (LET-X1)	LEFT GOV. PT.	LEFT GOV. PT.	RIGHT GOV. PT.	RIGHT GOV. PT.	EQ. 13.2	SEC. 7.13
1	45.0	11.0	4	1.53:0.24	1.53:0.24	1.53:0.24	1.53:0.24	3.87	3.87	5.76	5.76	15.7:0.4	2:05
2	45.0	11.0	4	1.53:0.24	1.53:0.24	1.53:0.24	1.53:0.24	3.87	3.87	5.76	5.76	15.7:0.4	2:05

TYPE CUT OF REFLECTING DETAILS

NOTIFY THE TOP PINS BASED ON FRONT ENVELOPE

NEGATIVE REINFORCEMENT

STRENGTHS AND DISTRIBUTION UNIFORMLY ACROSS THE COLUMN AND MIDDLE STRIPS.

REFLECTING IN SPANS

COL. NO.	SIZE	LONG BARS		SHORT BARS		MIDDLE STRIP		TOP BARS IN SPANS	
		LEFT	RIGHT	LEFT	RIGHT	LEFT	RIGHT	LEFT	RIGHT
1	4	3.7	3.7	3.7	3.7	4.2	4.2	0	0
2	4	3.7	3.7	3.7	3.7	4.2	4.2	0	0
3	6	3.7	3.7	3.7	3.7	4.2	4.2	0	0

COL. NO.	SIZE	LONG BARS		SHORT BARS		MIDDLE STRIP		TOP BARS IN SPANS	
		LEFT	RIGHT	LEFT	RIGHT	LEFT	RIGHT	LEFT	RIGHT
1	3	2.1	2.1	2.1	2.1	16.6	16.6	0	0
2	3	2.1	2.1	2.1	2.1	16.6	16.6	0	0
3	3	2.1	2.1	2.1	2.1	16.6	16.6	0	0

CONCRETE LINE

CONCRETE 1A 11/11/71

1-084649

MATERIAL QUANTITIES

TOTAL SLAB REINFORCEMENT IN ONE DIRECTION
ACTIVE STEEL 426.2 POUNDS POSITIVE STEEL 296.1 POUNDS

OTHER QUANTITIES
SURFACE AREA 661.1 SQ. FT. YARDAGE OF CONCRETE 17.27 CU. YD.
REINFORCEMENT PER AREA 1.445 POUNDS PER SQUARE FOOT, IN ONE DIRECTION

APPROXIMATE DEFLECTIONS

APPROXIMATE WIDESPAN DEFLECTIONS

NOTE 1) SEE PAGE OF USERS MANUAL FOR THE PLATE PLATE CENTER DEFLECTION
NOTE 2) REFER TO TABLE 9.51BT OF CODE FOR ALLOWABLE COMPUTED DEFLECTIONS

SPAN NO.	HEAD LOAD DEFL. (IN.)	MAX. LIVE LOAD DEFL. (IN.)	9.5.2.2 LONG TIME DEFL. (IN.)
1	5.829	8.213	0.093
2	5.829	8.213	0.073

APPROXIMATE CANTILEVER DEFLECTIONS (ITERATE LOADING FOR ALL DESIGN CONDITIONS - COMPUTED & INCLUDED)

CANTILEVER LEFT	HEAD LOAD DEFL. (IN.)	MAX. LIVE LOAD DEFL. (IN.)
1	0.026	0.026
2	0.026	0.026

85

COMPTON INC.

1-084843

LAVALLIN INC.
COSIGA INC.

615 RUE BELMONT MONTREAL

COSIGA INC.

PCA PROGRAM

FOR
FLAT PLATE SLAB WITH OR WITHOUT DROP PANEL

AND
WAFFLE STRUCTURE

DESIGN

86

PCA Program for the Analysis and Design of Flat Plates, Flat Slabs and Waffle Slabs

DATE: _____
 EXT: CONCRETE
 CONTRACT NO: 1675-2-6

MASTER CARD
 (only date)

WAFLE SLAB CARD
 (only for waffle slabs)

78
SLAB CARDS
 (up to 12)

COLUMN CARDS
 (up to 15)

Number of spans	Concrete weight (lb/ft ³)	Rib depth (in.)	Top slab thickness (in.)	Rib width of bottom (in.)	Story height above (ft)	Story height below (ft)	Relle of slab	Kern Numbers	Output apices	Vapors I	Perfor. Loadings				Rebar Code		
											Cl (ft)	C2 (ft)	D.L. (lb/ft)	C1 (ft)			
1	150	12	4	12	10	10	1	1	1	1							
2	150	12	4	12	10	10	1	1	1	1							
3	150	12	4	12	10	10	1	1	1	1							
4	150	12	4	12	10	10	1	1	1	1							
5	150	12	4	12	10	10	1	1	1	1							
6	150	12	4	12	10	10	1	1	1	1							
7	150	12	4	12	10	10	1	1	1	1							
8	150	12	4	12	10	10	1	1	1	1							
9	150	12	4	12	10	10	1	1	1	1							
10	150	12	4	12	10	10	1	1	1	1							
11	150	12	4	12	10	10	1	1	1	1							
12	150	12	4	12	10	10	1	1	1	1							
13	150	12	4	12	10	10	1	1	1	1							
14	150	12	4	12	10	10	1	1	1	1							
15	150	12	4	12	10	10	1	1	1	1							

CARTILEVER CARDS
(always 2)

SPECIFICATIONS CARDS
(only 1)

~~WIND LOAD~~
~~MOMENT CARDS~~
~~(add to 1)~~

~~WIND LOAD CARD~~
~~Use only if Wind ASD or A~~
~~(only if)~~

CASE

Length of cent. (ft)	Width of cent. (ft)	Live load (lb/ft²)	Superimposed D.L. (lb/ft²)	Allowable stress in concrete (ksi)	Use D.L. at edge (lb/ft²)	Spreads			Distance of edge from corner (ft)	Wind Load Applied
						1 (in.)	2 (in.)	3 (in.)		
11.8	11.4	50.7	31.5		50.0					
11.3	11.0	50.0	31.5		50.0					
10.8	10.6	50.0	31.5		50.0					
10.3	10.3	50.0	31.5		50.0					
9.8	9.8	50.0	31.5		50.0					
9.3	9.3	50.0	31.5		50.0					
8.8	8.8	50.0	31.5		50.0					
8.3	8.3	50.0	31.5		50.0					
7.8	7.8	50.0	31.5		50.0					
7.3	7.3	50.0	31.5		50.0					
6.8	6.8	50.0	31.5		50.0					
6.3	6.3	50.0	31.5		50.0					
5.8	5.8	50.0	31.5		50.0					
5.3	5.3	50.0	31.5		50.0					
4.8	4.8	50.0	31.5		50.0					
4.3	4.3	50.0	31.5		50.0					
3.8	3.8	50.0	31.5		50.0					
3.3	3.3	50.0	31.5		50.0					
2.8	2.8	50.0	31.5		50.0					
2.3	2.3	50.0	31.5		50.0					
1.8	1.8	50.0	31.5		50.0					
1.3	1.3	50.0	31.5		50.0					
0.8	0.8	50.0	31.5		50.0					
0.3	0.3	50.0	31.5		50.0					

Left Side (kip-ft)	Right Side (kip-ft)	Above (kip-ft)	Below (kip-ft)	Dist. from corner (ft)	Dist. from edge (ft)	Dist. from corner (ft)	Dist. from edge (ft)

Total load from above (lb/ft²)	Total load at base (lb/ft²)

INPUT DATA ARE AS FOLLOWS

MARK NUMBER ARE VX

NO. OF SPANS = 6 REINF. YIELD(ST1) = 50000.0 CONC. STRESS(ST1) = 4000.0
TENS.SPL.RT. = 0.0 CONCR.RATIO = 1.00

SPAN NO.	LENGTH (FT)	LIVE LD. (PSF)	SUPERIMP. DL (PSF)	PARTIAL LL (LB/LIN.FT)	C1 (FT)	C2 (FT)	PARTIAL DL (LB/LIN.FT)	C1 (FT)	C2 (FT)	SPANDREL BEAMS: STAY DEPTH (IN)	WIDTH (IN)	ECCENTRICITY (IN)
1	19.3	50.0	35.0	0.0	0.0	0.0	500.0	0.0	0.0	19.3	19.3	0.0
2	19.3	50.0	35.0	0.0	0.0	0.0	500.0	0.0	0.0	19.3	19.3	0.0
3	19.3	50.0	35.0	0.0	0.0	0.0	500.0	0.0	0.0	19.3	19.3	0.0
4	19.3	50.0	35.0	0.0	0.0	0.0	500.0	0.0	0.0	19.3	19.3	0.0
5	19.3	50.0	35.0	0.0	0.0	0.0	500.0	0.0	0.0	19.3	19.3	0.0

CANTILEVERS, IF ANY
END LENGTH WIDTH AT END LVL LOAD SUPP. DL LINE LL LIKE DL SPANDREL BEAMS: STAY DEPTH WIDTH ECCENTRICITY
LEFT (FT) (FT) (FT) (PSF) (PSF) (PSF) (LB/LIN.FT) (LB/LIN.FT) (FT) (FT) (IN) (IN) (IN)
RIGHT (FT) (FT) (FT) (PSF) (PSF) (PSF) (LB/LIN.FT) (LB/LIN.FT) (FT) (FT) (IN) (IN) (IN)

COL. NO.	THICKNESS (IN)	STORY HEIGHT ABOVE (FT)	STORY HEIGHT BELOW (FT)	STORY HEIGHT AT MIDSPAN (IN)	DESIGN BY	ULTIMATE STRENGTH
1	24.0	11.0	11.0	7.5	1	1.0
2	24.0	11.0	11.0	7.5	1	1.0
3	24.0	11.0	11.0	7.5	1	1.0
4	24.0	11.0	11.0	7.5	1	1.0
5	24.0	11.0	11.0	7.5	1	1.0
6	24.0	11.0	11.0	7.5	1	1.0

STORY HEIGHT ABOVE (FT) = 11.0
STORY HEIGHT BELOW (FT) = 11.0
STORY HEIGHT AT MIDSPAN (IN) = 7.5
DESIGN BY ULTIMATE STRENGTH = 1

DESIGN PART

B

CONCRETE

1-129090

SHEAR STRESSES

ALLOWABLE SHEAR STRESS FOR NORMAL WEIGHT CONCRETE - TWO WAY SLAB SHEAR STRESS = 252.9(PST) BEAM OR JOIST SHEAR STRESS = 186.4(PST)

COL. NO.	STRESS (PST)	TRANSFER OF MOMENT	GOV. PATT.	VERT. REACT. (K)	VERT. AROUND DROP (PST)	VERT. REACT. (K)	UNBAL. MOVEMENT (FT-K)	GOV. PATT.	SHEAR STRESS (PST)	TRANSFER OF MOMENT	GOV. PATT.	BENGD. MOM. (FT-K)	CALL. SECT. STEEL (IN)	CALL. WIDTH (IN)	CALL. FLEX. CAP. (FT-K)
1	44.333	4	4	61.5	20.0	61.5	-16.18	4	88.93	4	4	91.11	2.50	2.50	158.38
2	99.333	4	4	61.5	0.0	61.5	-12.24	4	105.00	4	4	0.00	2.50	2.50	109.49
3	104.333	4	4	71.6	0.0	71.6	0.00	4	104.00	4	4	0.00	2.50	2.50	109.49
4	104.333	4	4	71.6	0.0	71.6	0.00	4	104.00	4	4	0.00	2.50	2.50	109.49
5	104.333	4	4	71.6	0.0	71.6	0.00	4	104.00	4	4	0.00	2.50	2.50	109.49
6	99.333	4	4	61.5	20.0	61.5	-16.18	4	88.93	4	4	91.11	2.50	2.50	158.38
7	44.333	4	4	61.5	20.0	61.5	-16.18	4	88.93	4	4	91.11	2.50	2.50	158.38

PRINT-OUT OF STATICS

CCL.NO. PATTERN NO.1

LEFT RIGHT

PATT. NO.2 (FT-KIP)

LEFT RIGHT

PATT. NO.3

LEFT RIGHT

PATT. NO.4

LEFT RIGHT

SLAB MOMENTS	LEFT	RIGHT	LEFT	RIGHT	LEFT	RIGHT	LEFT	RIGHT
	-19.4819	11.7119	11.7119	11.7119	11.7119	11.7119	11.7119	11.7119
	-10.47767	11.7119	11.7119	11.7119	11.7119	11.7119	11.7119	11.7119
	-11.94423	11.7119	11.7119	11.7119	11.7119	11.7119	11.7119	11.7119
	-11.7119	11.7119	11.7119	11.7119	11.7119	11.7119	11.7119	11.7119

COLUMN MOMENTS (FT-KIP)	ABOVE	BELOW	ABOVE	BELOW	ABOVE	BELOW	ABOVE	BELOW
	64.7422	-97.4119	97.4119	97.4119	97.4119	97.4119	97.4119	97.4119
	0.0000	0.0000	0.0000	0.0000	0.0000	0.0000	0.0000	0.0000
	0.0000	0.0000	0.0000	0.0000	0.0000	0.0000	0.0000	0.0000
	64.00280	96.00280	96.00280	96.00280	96.00280	96.00280	96.00280	96.00280

SHEAR FORCES (KIP)	LEFT	RIGHT	LEFT	RIGHT	LEFT	RIGHT	LEFT	RIGHT
	-19.4819	11.7119	11.7119	11.7119	11.7119	11.7119	11.7119	11.7119
	-11.7119	11.7119	11.7119	11.7119	11.7119	11.7119	11.7119	11.7119
	-11.7119	11.7119	11.7119	11.7119	11.7119	11.7119	11.7119	11.7119
	-11.7119	11.7119	11.7119	11.7119	11.7119	11.7119	11.7119	11.7119

2

DESIGN FOR FLEXURE (FOR THE FIRST LAYER FROM BOTTOM.)

NEGATIVE REINFORCEMENT		POSITIVE REINFORCEMENT		STEEL COLUMN		STEEL AREA		INFL. EX. PT.		INFL. EX. PT.		NON-BY	
CLL. NO.	DESIGN (FT-K)	POINT	GCY. PATT.	BAL. RES. (FT-K)	COL. (SO. IN)	ROD (SO. IN)	LEFT (FT)	RIGHT (FT)	LEFT PATT.	RIGHT PATT.	EQ. 13.2	MIN BY 7.13	MIN BY 7.13
1	-137.46	101	4	190.18	1.36	0.91	4.80	4.80	4	4	137.0	137.0	137.0
2	-286.14	101	4	475.33	1.36	0.90	4.63	4.63	4	4	122.0	122.0	122.0
3	-272.15	101	4	475.33	1.36	0.90	4.63	4.63	4	4	122.0	122.0	122.0
4	-272.15	101	4	475.33	1.36	0.90	4.63	4.63	4	4	122.0	122.0	122.0
5	-272.15	101	4	475.33	1.36	0.90	4.63	4.63	4	4	122.0	122.0	122.0
6	-272.15	101	4	475.33	1.36	0.90	4.63	4.63	4	4	122.0	122.0	122.0
7	-272.15	101	4	475.33	1.36	0.90	4.63	4.63	4	4	122.0	122.0	122.0
8	-272.15	101	4	475.33	1.36	0.90	4.63	4.63	4	4	122.0	122.0	122.0
9	-272.15	101	4	475.33	1.36	0.90	4.63	4.63	4	4	122.0	122.0	122.0
10	-272.15	101	4	475.33	1.36	0.90	4.63	4.63	4	4	122.0	122.0	122.0
11	-272.15	101	4	475.33	1.36	0.90	4.63	4.63	4	4	122.0	122.0	122.0
12	-272.15	101	4	475.33	1.36	0.90	4.63	4.63	4	4	122.0	122.0	122.0
13	-272.15	101	4	475.33	1.36	0.90	4.63	4.63	4	4	122.0	122.0	122.0
14	-272.15	101	4	475.33	1.36	0.90	4.63	4.63	4	4	122.0	122.0	122.0
15	-272.15	101	4	475.33	1.36	0.90	4.63	4.63	4	4	122.0	122.0	122.0
16	-272.15	101	4	475.33	1.36	0.90	4.63	4.63	4	4	122.0	122.0	122.0
17	-272.15	101	4	475.33	1.36	0.90	4.63	4.63	4	4	122.0	122.0	122.0
18	-272.15	101	4	475.33	1.36	0.90	4.63	4.63	4	4	122.0	122.0	122.0
19	-272.15	101	4	475.33	1.36	0.90	4.63	4.63	4	4	122.0	122.0	122.0
20	-272.15	101	4	475.33	1.36	0.90	4.63	4.63	4	4	122.0	122.0	122.0
21	-272.15	101	4	475.33	1.36	0.90	4.63	4.63	4	4	122.0	122.0	122.0
22	-272.15	101	4	475.33	1.36	0.90	4.63	4.63	4	4	122.0	122.0	122.0
23	-272.15	101	4	475.33	1.36	0.90	4.63	4.63	4	4	122.0	122.0	122.0
24	-272.15	101	4	475.33	1.36	0.90	4.63	4.63	4	4	122.0	122.0	122.0
25	-272.15	101	4	475.33	1.36	0.90	4.63	4.63	4	4	122.0	122.0	122.0
26	-272.15	101	4	475.33	1.36	0.90	4.63	4.63	4	4	122.0	122.0	122.0
27	-272.15	101	4	475.33	1.36	0.90	4.63	4.63	4	4	122.0	122.0	122.0
28	-272.15	101	4	475.33	1.36	0.90	4.63	4.63	4	4	122.0	122.0	122.0
29	-272.15	101	4	475.33	1.36	0.90	4.63	4.63	4	4	122.0	122.0	122.0
30	-272.15	101	4	475.33	1.36	0.90	4.63	4.63	4	4	122.0	122.0	122.0
31	-272.15	101	4	475.33	1.36	0.90	4.63	4.63	4	4	122.0	122.0	122.0
32	-272.15	101	4	475.33	1.36	0.90	4.63	4.63	4	4	122.0	122.0	122.0
33	-272.15	101	4	475.33	1.36	0.90	4.63	4.63	4	4	122.0	122.0	122.0
34	-272.15	101	4	475.33	1.36	0.90	4.63	4.63	4	4	122.0	122.0	122.0
35	-272.15	101	4	475.33	1.36	0.90	4.63	4.63	4	4	122.0	122.0	122.0
36	-272.15	101	4	475.33	1.36	0.90	4.63	4.63	4	4	122.0	122.0	122.0
37	-272.15	101	4	475.33	1.36	0.90	4.63	4.63	4	4	122.0	122.0	122.0
38	-272.15	101	4	475.33	1.36	0.90	4.63	4.63	4	4	122.0	122.0	122.0
39	-272.15	101	4	475.33	1.36	0.90	4.63	4.63	4	4	122.0	122.0	122.0
40	-272.15	101	4	475.33	1.36	0.90	4.63	4.63	4	4	122.0	122.0	122.0
41	-272.15	101	4	475.33	1.36	0.90	4.63	4.63	4	4	122.0	122.0	122.0
42	-272.15	101	4	475.33	1.36	0.90	4.63	4.63	4	4	122.0	122.0	122.0
43	-272.15	101	4	475.33	1.36	0.90	4.63	4.63	4	4	122.0	122.0	122.0
44	-272.15	101	4	475.33	1.36	0.90	4.63	4.63	4	4	122.0	122.0	122.0
45	-272.15	101	4	475.33	1.36	0.90	4.63	4.63	4	4	122.0	122.0	122.0
46	-272.15	101	4	475.33	1.36	0.90	4.63	4.63	4	4	122.0	122.0	122.0
47	-272.15	101	4	475.33	1.36	0.90	4.63	4.63	4	4	122.0	122.0	122.0
48	-272.15	101	4	475.33	1.36	0.90	4.63	4.63	4	4	122.0	122.0	122.0
49	-272.15	101	4	475.33	1.36	0.90	4.63	4.63	4	4	122.0	122.0	122.0
50	-272.15	101	4	475.33	1.36	0.90	4.63	4.63	4	4	122.0	122.0	122.0

TYPE CUT OF REINFORCING DETAILS

NOTE--LENGTH OF TOP BARS BASED ON MOMENT ENVELOPE

REINFORCING REINFORCEMENT

NOTE--BARS ARE DISTRIBUTED UNIFORMLY ACROSS THE COLUMN AND MIDDLE STRIPS.

CUL NO.	BAR SIZE	NO.	COLUMN STRIP		MIDDLE STRIP		SHORT BARS	
			LONG BARS	SHORT BARS	LONG BARS	SHORT BARS	LEFT	RIGHT
1	N 5	2	1.8	7.3	1.8	4.2	0.0	0.0
2	N 5	4	3.7	3.7	3.7	4.2	0.0	0.0
3	N 5	4	5.7	3.7	3.7	4.2	0.0	0.0
4	N 5	4	5.7	3.7	3.7	4.2	0.0	0.0
5	N 5	4	5.7	3.7	3.7	4.2	0.0	0.0
6	N 5	4	5.7	3.7	3.7	4.2	0.0	0.0
7	N 5	4	5.7	3.7	3.7	4.2	0.0	0.0
8	N 5	4	5.7	3.7	3.7	4.2	0.0	0.0
9	N 5	4	5.7	3.7	3.7	4.2	0.0	0.0
10	N 5	4	5.7	3.7	3.7	4.2	0.0	0.0
11	N 5	4	5.7	3.7	3.7	4.2	0.0	0.0
12	N 5	4	5.7	3.7	3.7	4.2	0.0	0.0
13	N 5	4	5.7	3.7	3.7	4.2	0.0	0.0
14	N 5	4	5.7	3.7	3.7	4.2	0.0	0.0
15	N 5	4	5.7	3.7	3.7	4.2	0.0	0.0
16	N 5	4	5.7	3.7	3.7	4.2	0.0	0.0
17	N 5	4	5.7	3.7	3.7	4.2	0.0	0.0
18	N 5	4	5.7	3.7	3.7	4.2	0.0	0.0
19	N 5	4	5.7	3.7	3.7	4.2	0.0	0.0
20	N 5	4	5.7	3.7	3.7	4.2	0.0	0.0
21	N 5	4	5.7	3.7	3.7	4.2	0.0	0.0
22	N 5	4	5.7	3.7	3.7	4.2	0.0	0.0
23	N 5	4	5.7	3.7	3.7	4.2	0.0	0.0
24	N 5	4	5.7	3.7	3.7	4.2	0.0	0.0
25	N 5	4	5.7	3.7	3.7	4.2	0.0	0.0
26	N 5	4	5.7	3.7	3.7	4.2	0.0	0.0
27	N 5	4	5.7	3.7	3.7	4.2	0.0	0.0
28	N 5	4	5.7	3.7	3.7	4.2	0.0	0.0
29	N 5	4	5.7	3.7	3.7	4.2	0.0	0.0
30	N 5	4	5.7	3.7	3.7	4.2	0.0	0.0
31	N 5	4	5.7	3.7	3.7	4.2	0.0	0.0
32	N 5	4	5.7	3.7	3.7	4.2	0.0	0.0
33	N 5	4	5.7	3.7	3.7	4.2	0.0	0.0
34	N 5	4	5.7	3.7	3.7	4.2	0.0	0.0
35	N 5	4	5.7	3.7	3.7	4.2	0.0	0.0
36	N 5	4	5.7	3.7	3.7	4.2	0.0	0.0
37	N 5	4	5.7	3.7	3.7	4.2	0.0	0.0
38	N 5	4	5.7	3.7	3.7	4.2	0.0	0.0
39	N 5	4	5.7	3.7	3.7	4.2	0.0	0.0
40	N 5	4	5.7	3.7	3.7	4.2	0.0	0.0
41	N 5	4	5.7	3.7	3.7	4.2	0.0	0.0
42	N 5	4	5.7	3.7	3.7	4.2	0.0	0.0
43	N 5	4	5.7	3.7	3.7	4.2	0.0	0.0
44	N 5	4	5.7	3.7	3.7	4.2	0.0	0.0
45	N 5	4	5.7	3.7	3.7	4.2	0.0	0.0
46	N 5	4	5.7	3.7	3.7	4.2	0.0	0.0
47	N 5	4	5.7	3.7	3.7	4.2	0.0	0.0
48	N 5	4	5.7	3.7	3.7	4.2	0.0	0.0
49	N 5	4	5.7	3.7	3.7	4.2	0.0	0.0
50	N 5	4	5.7	3.7	3.7	4.2	0.0	0.0

REINFORCING IN SPANS

SPAN NO.	BAR SIZE	LONG BARS	COLUMN STRIP		MIDDLE STRIP		SHORT BARS	
			LONG BARS	SHORT BARS	LONG BARS	SHORT BARS	LEFT	RIGHT
1	N 5	2	16.5	2	16.5	0.0	0.0	
2	N 5	2	18.8	2	18.8	0.0	0.0	
3	N 5	2	18.8	2	18.8	0.0	0.0	
4	N 5	2	18.8	2	18.8	0.0	0.0	
5	N 5	2	18.8	2	18.8	0.0	0.0	
6	N 5	2	18.8	2	18.8	0.0	0.0	
7	N 5	2	18.8	2	18.8	0.0	0.0	
8	N 5	2	18.8	2	18.8	0.0	0.0	
9	N 5	2	18.8	2	18.8	0.0	0.0	
10	N 5	2	18.8	2	18.8	0.0	0.0	
11	N 5	2	18.8	2	18.8	0.0	0.0	
12	N 5	2	18.8	2	18.8	0.0	0.0	
13	N 5	2	18.8	2	18.8	0.0	0.0	
14	N 5	2	18.8	2	18.8	0.0	0.0	
15	N 5	2	18.8	2	18.8	0.0	0.0	
16	N 5	2	18.8	2	18.8	0.0	0.0	
17	N 5	2	18.8	2	18.8	0.0	0.0	
18	N 5	2	18.8	2	18.8	0.0	0.0	
19	N 5	2	18.8	2	18.8	0.0	0.0	
20	N 5	2	18.8	2	18.8	0.0	0.0	
21	N 5	2	18.8	2	18.8	0.0	0.0	
22	N 5	2	18.8	2	18.8	0.0	0.0	
23	N 5	2	18.8	2	18.8	0.0	0.0	
24	N 5	2	18.8	2	18.8	0.0	0.0	
25	N 5	2	18.8	2	18.8	0.0	0.0	
26	N 5	2	18.8	2	18.8	0.0	0.0	
27	N 5	2	18.8	2	18.8	0.0	0.0	
28	N 5	2	18.8	2	18.8	0.0	0.0	
29	N 5	2	18.8	2	18.8	0.0	0.0	
30	N 5	2	18.8	2	18.8	0.0	0.0	
31	N 5	2	18.8	2	18.8	0.0	0.0	
32	N 5	2	18.8	2	18.8	0.0	0.0	
33	N 5	2	18.8	2	18.8	0.0	0.0	
34	N 5	2	18.8	2	18.8	0.0	0.0	
35	N 5	2	18.8	2	18.8	0.0	0.0	
36	N 5	2	18.8	2	18.8	0.0	0.0	
37	N 5	2	18.8	2	18.8	0.0	0.0	
38	N 5	2	18.8	2	18.8	0.0	0.0	
39	N 5	2	18.8	2	18.8	0.0	0.0	
40	N 5	2	18.8	2	18.8	0.0	0.0	
41	N 5	2	18.8	2	18.8	0.0	0.0	
42	N 5	2	18.8	2	18.8	0.0	0.0	
43	N 5	2	18.8	2	18.8	0.0	0.0	
44	N 5	2	18.8	2	18.8	0.0	0.0	
45	N 5	2	18.8	2	18.8	0.0	0.0	
46	N 5	2	18.8	2	18.8	0.0	0.0	
47	N 5	2	18.8	2	18.8	0.0	0.0	
48	N 5	2	18.8	2	18.8	0.0	0.0	
49	N 5	2	18.8	2	18.8	0.0	0.0	
50	N 5	2	18.8	2	18.8	0.0	0.0	

MATERIAL QUANTITIES

TOTAL STEEL REINFORCEMENT IN ONE DIRECTION 842.1 POUNDS
 NEGATIVE STEEL 756.6 POUNDS POSITIVE STEEL
 OTHER QUANTITIES 35.15 CUBIC YARD
 SURFACE AREA 1561.1 SQUARE FEET YARDAGE OF CONCRETE PER SQUARE FOOT, IN ONE DIRECTION
 REINFORCEMENT PER AREA 1.203 POUNDS PER SQUARE FOOT, IN ONE DIRECTION

APPROXIMATE DEFLECTIONS

APPROXIMATE W/SPAN DEFLECTIONS

NOTE 1) SEE PAGE 70 TABLE 9.5(B) OF USERS MANUAL FOR THE FLAT PLATE PANEL CENTER DEFLECTION
 NOTE 2) REFER TO TABLE 9.5(B) OF CODE FOR ALLOWABLE COMPUTED DEFLECTIONS

SPAN NO.	DEAD LOAD DEFL. (IN.)	W/SPAN DEF. (IN.)	9.5.2.2 CODE LIMIT
1	0.033	0.011	0.035
2	0.123	0.041	0.333
3	0.126	0.042	0.340
4	0.152	0.043	0.349
5	0.032	0.011	0.077

APPROXIMATE CANTILEVER DEFLECTIONS (ALTERNATE LOADING FOR ALL DESIGN CONDITIONS, CONDITION 1 INCLUDED)
 APPROXIMATE CANTILEVER DEAD LOAD DEF. (IN.) MAX. LIVE LOAD DEF. (IN.)
 LEFT -0.012 0.000
 RIGHT -0.012 0.000