

**DESIGN AND CONSTRUCTION REQUIREMENTS  
FOR  
PRECAST COLUMN CONNECTIONS**

**WIERA KROLIKOWSKA**

**A MAJOR TECHNICAL REPORT  
IN  
THE DEPARTMENT  
OF  
CIVIL ENGINEERING**

**Presented in partial fulfillment of the requirement  
for the degree of Master of Engineering at  
Concordia University  
Montreal, Quebec, Canada**

**April 1979**

**© Wiera Krolikowska, 1979**

ABSTRACT  
DESIGN AND CONSTRUCTION REQUIREMENTS  
FOR  
PRECAST COLUMN CONNECTIONS

Wiera Krolikowska

The growing popularity of precast concrete structures has led to a rapid development of connections suitable for this type of construction.

Although there exists a large number of standardized precast element connections this report is limited to discussion of column connections.

The influence of the bearing capacity of concrete and of other factors on the design and performance of such connections is outlined.

Presently used connections, those standardized by Prestressed Concrete Institute and used by Manufacturers and Designers, are presented and described briefly.

TABLE OF CONTENTS

	<u>Page No.</u>
ABSTRACT	1
TABLE OF CONTENTS	11
1.0 INTRODUCTION	1
2.0 CONSIDERATIONS FOR CONNECTIONS DESIGN	3
2.1 General	3
2.2 Forces and Movements to be considered	4
2.2.1 Vertical Forces and Movements	4
2.2.2 Horizontal Forces and Movements	5
2.2.3 Stability of Structure	6
2.2.4 Erection Forces	10
2.2.5 Safety Factors	11
2.2.6 Tolerances	12
3.0 BEARING CAPACITY OF CONCRETE AND PRECAST COLUMNS	15
3.1 Bearing on Plain Concrete -- PCI Recommendations	15
3.1.1 Bearing of Confined Concrete -- PCI Recommendations	17
3.1.2 Bearing Pads -- PCI Recommendations	18
3.2 Review of Research on Bearing Capacity of Concrete and Precast Columns	18
3.2.1 Bearing Capacity of Concrete	18
3.2.2 Bearing Capacity of Column Heads	19
4.0 EXAMPLES OF COLUMN CONNECTIONS	29
4.1 Column to Foundation Joints	29
4.1.1 Column to Base Socket type Connections	29
4.1.2 Column to Base Dowel type Connections	31
4.1.3 Column to Base < Base plate type Connections	33
4.2 Column to Column Joints	33
4.2.1 Column to Column Base Plate type Connections	35
4.2.2 Column to Column Dowel type Connections	35
4.2.3 Column to Column Precision type Connections	38
5.0 CONCLUSION	46
APPENDIX I - REFERENCES	48
APPENDIX II - NOTATIONS	50
APPENDIX III - LIST OF FIGURES	51

## 1.0 INTRODUCTION

Today more than ever, building economy calls for new concepts and methods in the construction industry. Reduction of costs while maintaining or improving the standards of construction is at the heart of every successful building project.

The concept of prefabricated structures as opposed to in-situ construction is not new, but in Canada, the trend towards this type of construction is only beginning although research and practical applications have been taking place, on a modest scale, for more than two decades. The present growing acceptance of the concept is closely related to the economics of construction and to quality standards of structures.

From the very beginning, it was recognized that while prefabricated structures shorten erection time, cut cost and reduce the need for increasingly expensive skilled labour, the full benefits are only available in mass production and this, initially, limited the acceptance of the concept.

Individual or occasional application of prefabrication principles fail to achieve the full economical potential inherent in the concept. Prefabricated structural components must be standardized and designed for mass-production to cut the cost of the structures.

In industrial, commercial and high-rise structures, the most widely used design system is the rigid frame. It offers freedom in the choice of material and in planning of the floor layout.

Both steel and concrete are used for frame construction.

The elements of prefabricated frame structures can be easily standardized and have been so the items critical for mass-production and requiring modern precision techniques are the joints.

It is not an exaggeration to say that the methods of joining of prefabricated elements set the standard of quality of the structure and the associated problems are a cause of slow progress made by the buildings assembled entirely from factory produced components.

At the moment, the available joints are rather costly, tend to be inaccurate, and require skilled labour for manufacturing and erection.

The following report, will provide a brief description of standardized joints, characteristics of materials used, structural and design considerations with emphasis on the "Design and Construction Requirements for Precast Column Connections."

## 2.0 CONSIDERATIONS FOR CONNECTIONS DESIGN

### 2.1 General

In precast concrete structures, the practical and economic requirements of joint design have a major influence on system selection. The connections must be designed in the manner that they are capable of withstanding the ultimate vertical and horizontal design loads without excessive deformation or rotation. Ideally the strength of connections should exceed that of the members connected.

Due to the key role played by the connections in precast concrete structures, the usual procedure is to make the selection of the joint type and fabrication the first step in design, and to let the rest of the structural system follow from it.

When choosing the type of connection, it is necessary to take the following into account:

- a) **Aesthetics** - connections should have a pleasing appearance for architectural reasons.
- b) **Structural Reliability** - joints should not allow deformations sufficient to cause cracking of the members.
- c) **Ease of erection** - joints should be easily handled by unskilled labour with practical tolerances and should be

accessible for inspection when completed.

- d) Ease of Manufacturing - tolerances should allow the use of common manufacturing operations and whenever possible structural elements available in standard shapes should be selected.
- e) Low cost

## 2.2 Forces and Movements to be Considered

Connections in prefabricated structures as other structures are subjected to forces due to imposed dead and live loads, wind, earthquake and forces due to change of dimensions of members and differential movements.

### 2.2.1 Vertical Forces and Movements

Vertical loads, dead, and live vertical reactions induced by wind and seismic forces are those computed in a conventional way appropriate for the structural system adopted.

Vertical movements and forces due to volume change caused by shrinkage or temperature change are not critical for vertical members. Shortening due to shrinkage after about 30 days should not be of concern and column length changes due to temperature need be calculated only in the case of tall structures.

### 2.2.2 Horizontal Forces and Movement

Movements and horizontal shear forces are due to wind, seismic forces and are also created by horizontal movements due to instantaneous or time-dependent (creep) deformations, expansion or shrinkage due to chemical or humidity changes, expansion or contraction due to changes in temperature. Restraints in connections due to friction, welding on both ends of a member, or other causes which prevent axial movement of members result in additional horizontal forces in the connections and reduce the capacity of the connections.

Connections have to be designed to resist forces due to volume changes unless special connection details or materials are used to reduce restraint build-up.

With respect to horizontal seismic forces the Uniform Building Code as quoted in reference (2) recommends the following provisions:

- a) Connections and panel joints shall allow for relative movement between stories of not less than two times the story drift caused by wind or seismic forces, or 1/4 inch -- whichever is greater.
- b) Connections should have sufficient ductility, rotation capacity to prevent fracture of the concrete or brittle



failures at or near the welds. Inserts in concrete shall be attached to or hooked around reinforcing steel or otherwise terminated so as to effectively transfer forces to the reinforcing steel.

### 2.2.3 Stability of Structure

When considering stability, it is important to recognize the contribution of various components of the structural schema to the overall stability of low and multi-storey buildings.

Generally, the stability of a structure is assured by the following, singly or in combination:

1. Fixity of columns at the base.
2. Rigid frame connections.
3. Shear walls and floor slabs.
4. Rigid cores and floor slabs.

Low structures generally rely on column fixity. The foundation must be able to resist forces acting on it, especially those from bending moments.

In multi-storey buildings, columns fixed at the base are used only up to about four stories. For higher structures, one or several of the other methods listed would be used.

Rigid frames can be used to assure a stable skeleton of the structure or a stable core, located centrally or on the side, to which the rest of the structure is linked. The frame can be prefabricated or post-tensioned see Figs. 3 and 4.

In very tall structures, when horizontal forces are too high to be absorbed by the frame, shear walls or cores are used. In that case, one of few available types of frames are used in longitudinal directions.

Type of double "T" frames or "H" frames such as shown in Fig. 3 give very good stability along the façade. Double "T" have the connections at the bottom. In "H" frames, connections are located half-way up the storey as bending moment magnitudes indicate.

Generally, it is difficult to obtain adequate joint rigidity at the intersection of vertical and horizontal prefabricated members. Available space there is limited and forces to be absorbed are high. Therefore, it is important to try to make the connections away from the structural meeting points in areas where, if possible, the bending moment is zero.

For the illustration of the most appropriate location of column connections see Fig 1 and 2 which show the bending moment diagrams due to horizontal forces in common frame structures.

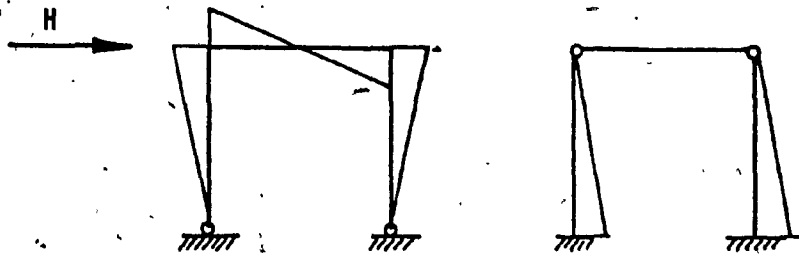

FIG.1 PORTAL FRAME STRUCTURES MOMENTS DUE TO HORIZONTAL FORCE

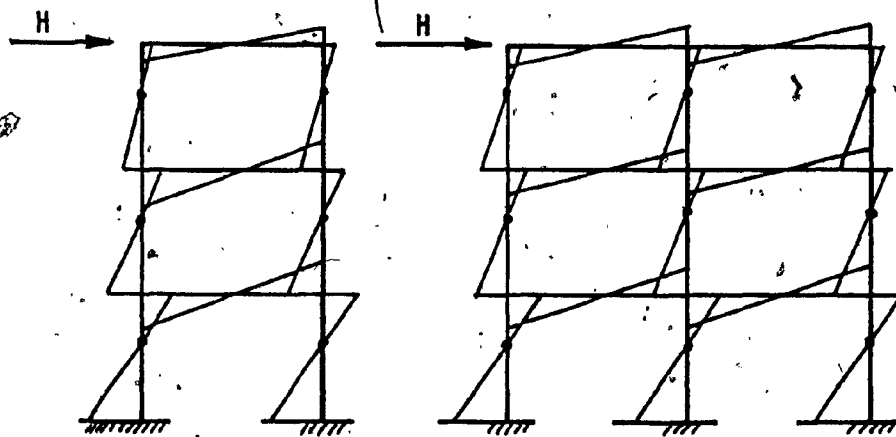

FIG.2 MULTY STOREY FRAME STRUCTURES MOMENTS DUE TO HORIZONTAL FORCE

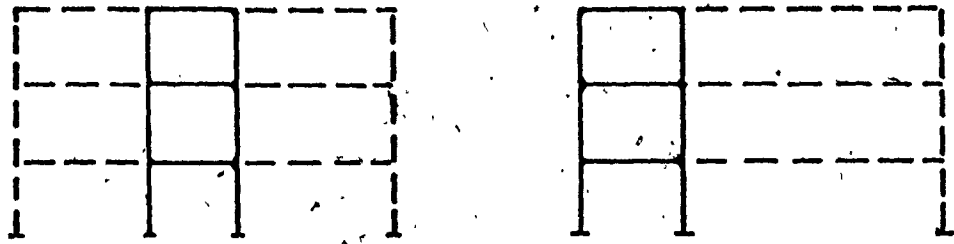
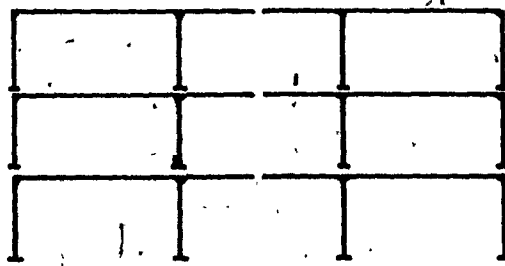
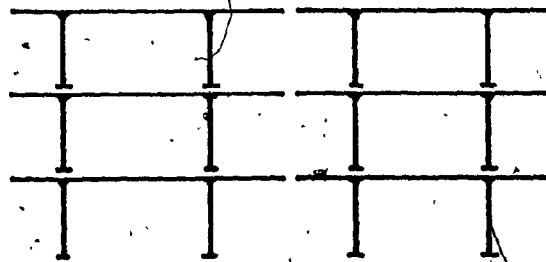

FIG. 3 STRUCTURES WITH RIGID FRAMES



a) IDENTICAL FRAMES



b) DOUBLE "T" FRAMES

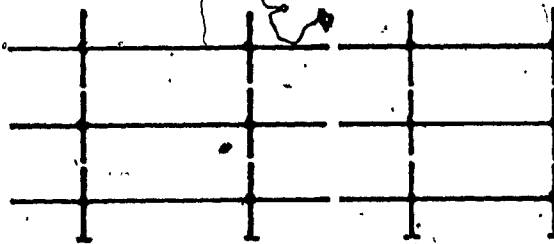

c) "H" FRAMES

FIG. 4 STRUCTURES COMPOSED OF FRAMES

#### 2.2.4 Erection Forces.

Erection exposes the structural precast members and connections to different and sometimes more severe loading conditions than those that the finished structure may experience under full service loads. The forces and stresses during this temporary stage have to be considered in design and proper attention should be given to the influence of the sequence of erection. Possible eccentric loading and continuity moment connections over supports shall be considered carefully at the erection stage. Sequence in erection of members and connections, with shoring or guying should be clearly outlined in the specification. Connections should be designed in such a manner that temporary bracing and connections would allow for release of erection equipment as soon as possible with the erected members being stable.

Simplicity is required, number of bolts and nuts should be kept to a minimum and the least number of operations required for final levelling or plumbing of columns. Welds, once made should be final.

Shims are the most commonly used method of levelling of members. Precast members that are welded, bolted or grouted in the final stage will usually be set on shims at first.

It is very important that all bearing surfaces be in full contact with bearing supports, otherwise local stress concentrations will tend to weaken the connections and may cause damage to members.

Special problems during erection are created by wind forces. PCI (Prestressed Concrete Institute) recommends the use of 30 psf pressure on projected surface of structural elements. This corresponds to a wind velocity 100 mph.

ACI (American Concrete Institute), (2), recommends for the design of temporary bracing the use of wind forces determined as follows:

$$D = C_d (1/2 \rho V^2) A \quad (1b)$$

where:

$C_d$  = 1.8 -- Drag coefficient

$\rho$  = 0.002378 = Mass density of air at sea

level and temperature, 59°F, slugs/cu.ft.

D = Wind force, lb.

V = Wind velocity, mph.

A = Exposed area, sf.

#### 2.2.5 Safety Factors

Importance of connections in precast concrete structure calls for safety factors which assure that connections will not fail before the concrete members fail. ACI recommends that an

additional safety factor of 1.1 be applied over and above the normal (1.4D and 1.7L). PCI recommends a factor of 1.33 for the ultimate design of connections. This factor is to be applied to fully factored design loads.

In load combination (1.4D + 1.7L) and 0.75 (1.4D + 1.7L) volume change forces should be included with dead load, except for bracket and corbels where they should be included in 1.7L.

#### 2.2.6 Tolerances

Connection design should allow for the most unfavourable combination of manufacturing and erection tolerances. Tolerances have to be given to the pre-caster and provision made for necessary field adjustments during the erection. Precision is required in both instances to avoid a build-up of cumulative dimensional errors.

Fractional differences in members will build up to inches in long spans or heights. PCI refers to the "Manual for Quality Control for Plants and Production of Precast, Prestressed Concrete Products", MNL 116-70 for the recommended tolerances for precast members.

The recommended tolerances are listed in the following Table:

<u>Item</u>	<u>Recommended Tolerances*: inches</u>
Field placed anchor bolts (transit or template)	$\pm 1/4$
Elevation of field cast footings and piers	$\pm 5/8$
<u>Structural Precast Concrete</u>	
Position of Plates	$\pm 1$
Location of inserts	$\pm 1/2$
Location of bearing plates	$\pm 1/2$
Location of blockouts	$\pm 1/2$
Length	$\pm 3/4$
Overall depth	$\pm 1/4$
Width of stem	$\pm 1/8$
Overall width	$\pm 1/4$
Horizontal deviation of ends from square	$\pm 1/4$
Vertical deviation of ends from square	$\pm 1/8$ per ft. of height
Bearing deviation from plane	$\pm 1/8$
Position of post-tensioning ducts in precast members	$\pm 1/4$



---

Item	Recommended Tolerances*: inches
------	---------------------------------

---

Architectural Precast Concrete

Length or width	<u>+ 1/16</u> per 10 ft. but not less than <u>+ 1/8</u>
Thickness	<u>+ 1/4</u> , - 1/8
Location of blockouts	<u>+ 1/2</u>
Location of anchors and inserts	<u>+ 3/8</u>
Warpage or squareness	<u>+ 1/8</u> in 6 ft.
Joint widths	
- specified	3/8 to 5/8 in.
- min. and max. dimensions	1/4 and 3/4 in.

---

\* Other construction materials may control tolerances selected.

3.0 BEARING CAPACITY OF CONCRETE AND PRECAST COLUMNS

In designing of bearing connections bearing capacity of concrete as function of type of loading, shape of bearing area, magnitude of bearing stress and eccentricities of loads shall be considered.

3.1 Bearing on Plain Concrete -- PCI Recommendations

According to PCI recommendations (Fig. 5) for uniform loading, the ultimate concrete bearing strength can be calculated using the formula:

$$f_{bu} = \phi 70 \sqrt{f_{c'}} \sqrt[3]{\frac{s}{w}}$$

where:  $\phi = 0.7$  is the ultimate load factor

$s$  = Distance from free edge to centre of bearing, in.

$w$  = Width of bearing plate perpendicular to free edge, in.

For non-uniform bearing stress at any point shall not exceed that given by above formula for  $\frac{s}{w} = 0.5$

If a horizontal force is present then

$$f_{bu} = Cr \phi 70 \sqrt{f_{c'}} \sqrt[3]{\frac{s}{w}}$$

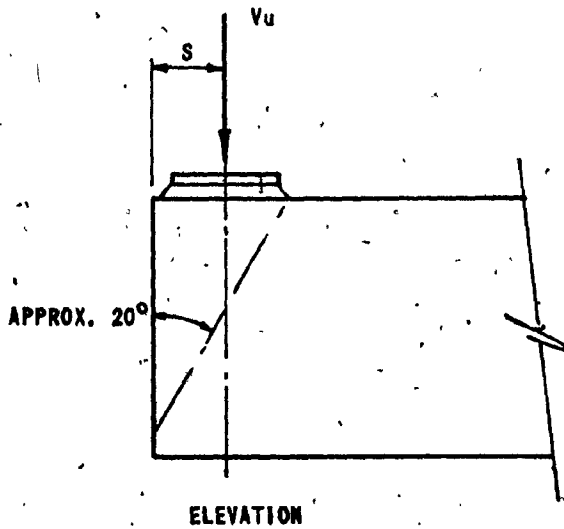
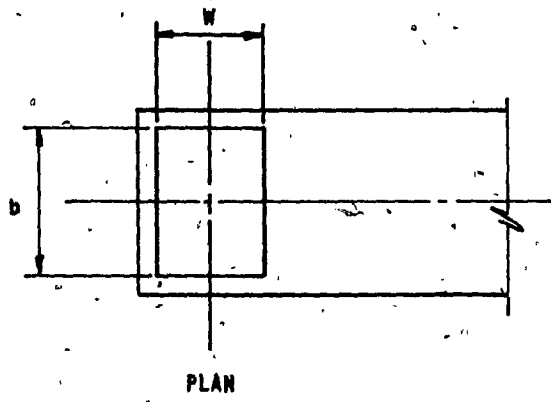

FIG.5 BEARING ON PLAIN CONCRETE (PCI)

$$\text{where } Cr = \left[ \frac{sw}{.200} \right] \frac{T_u}{V_u}$$

for light-weight structural concrete  $f_{bu} = 0.85$  of the value calculated for normal weight concrete.

where  $T_u$  = Ultimate tensile force acting with  $V_u$ , lb.

$V_u$  = Ultimate shear applied to connection, lb.

### 3.1.1 Bearing on Confined Concrete - PCI Recommendations

The ultimate vertical bearing stress should not exceed  $0.85 f_c'$ .

The area of reinforcement required in order to provide strength against vertical bearing cracks, welded to confinement angles can be determined by:

$$A_{vf} = \frac{1}{\phi f_{yv}} \left[ \frac{V_u}{\mu} + T_u \right]$$

where:  $\phi = 0.85$

$T_u \geq 0.2 V_u$

$\mu$  = shear - friction coefficient

$f_{yv}$  = yield strength for  $A_{vf}$  (psi)

Area of reinforcement required in order to provide strength against horizontal cracks can be determined by:

$$A_{sh} = \frac{A_{vf} f_{yv}}{j f_{ys}}$$

where:  $f_{ys}$  = yield strength for  $A_{sh}$ . (psi)

Additional confinement reinforcement provided in both directions can be calculated as follows:

$$A_{cv} = A_{ch} = \frac{V_u}{8 f_y}$$

### 3.1.2 Bearing Pads - PCI Recommendations

If bearing pads are used, the design bearing stresses should be lower and the design based on the working stress method.

Maximum compressive stresses are specified and recommended by PCI and depend on the type and properties of materials used.

Data are given for: Laminated fabric pads, laminated fabric-rubber pads, frictionless pads. Other types of pads may be allowed at discretion of the engineer.

### 3.2 Review of Research on Bearing Capacity of Concrete and Precast Columns

#### 3.2.1 Bearing Capacity of Concrete

It should be mentioned that some research tests (6) show that the cube-root formula for local pressure proposed by Bauschinger and based on tests of sand stone cubes, is not an appropriate expression for the bearing strength of concrete.

The material in the region of the localized force is subjected to stresses of complex nature, and the behaviour is further complicated by the non-homogeneity and in-elasticity of concrete.

The following variables were considered in the experiments reported in (6):

- a) Geometry; dimensions of loaded area relative to those of bearing plates; strip and rectangular, height of specimens and eccentricities of the bearing plate.
- b) Nature of bed, rigid or yielding.
- c) The bearing area at the supported end of the specimen.

The test results indicated that cube-root formula underestimates the ultimate bearing strength for square loading, while over-estimates it for strip loadings. In general, strength decreases with increasing height of specimen and also with increasing eccentricity of the load. Strength of smaller loaded areas is affected more by eccentricity than that of larger ones.

### 3.2.2 Bearing Capacity of Column Heads

In precast concrete structures, column heads at column to column or column to beam connections are an area of large concentration of vertical and horizontal forces.

The bursting tensile force is proportional to the force applied and depends on size of anchorage in relation to the end block dimensions. See Fig. 6.

In other words:

$$\frac{F_{bst}}{P} = \frac{Y}{Y_{po}}$$

where:  $F_{bst}$  = Bursting tensile force in one direction

$P$  = Load applied

$Y_{po}$  = Dimension of end block perpendicular to direction  
of considered  $F_{bst}$

$Y$  = Dimension of anchorage plate

Multiple anchorages for post-tensioned structures are treated as a series of loaded prisms with the bursting force acting in both transverse directions. Strip loading applied on the column head seems analogous to that situation and, since for a square prism loaded over its full width  $\frac{F_{bst}}{P} = \frac{Y}{Y_{po}} = 1.0$ , it follows that

$F_{bst} = P$  in one direction. The finding of over-estimated bearing capacity for strip loads which can be seen as series of loads reported in the experiments mentioned in Section 5.2.1 can be correlated with the view.

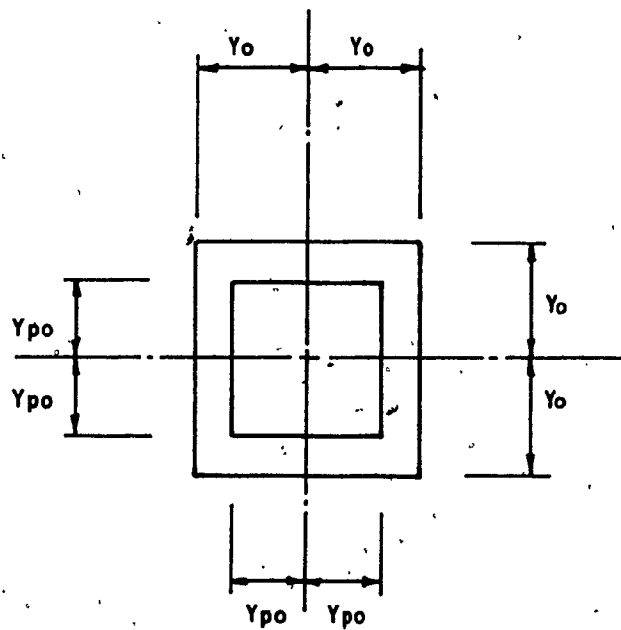

PLAN

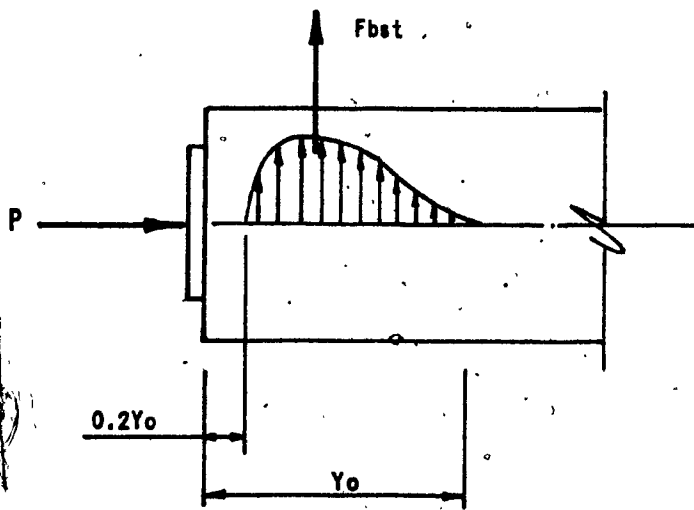

ELEVATION

FIG. 6 END BLOCK-BURSTING TENSILE FORCE POST-TENSIONED CONCRETE ANALOGY



The analogy between column heads of prefabricated structures and the anchorage zone of prestressed concrete block subjected to concentrated loads should be noted here. On many occasions theoretical calculations of bearing capacity of concrete and of stress distribution in the anchorage zone, have been attempted but due to the complexity of forces and to material character only experimental studies can lead to accurate predictions of bearing capacity of concrete.

In the immediate vicinity of load application there exists a complex system of stresses in the two directions transverse to the direction of force applied, and therefore the stress field as a whole is three-dimensional.

The stresses may be sufficient to cause cracking of the concrete and, in the absence of the reinforcement, failure.

In the design of prestressed concrete end block the usual practice is to assess the total force, "bursting force", in each transverse direction and to provide reinforcement of appropriate strength. The code for prestressed concrete tabulates the recommended design values of the bursting force resulting from the application of axial force on a square concrete block.

Present code provisions for bearing stress are the result of many analytical and experimental studies, some of which were done by PCA (Prestressed Concrete Association).

The test results (6) confirmed that bearing strength of concrete is a function of: compressive strength of concrete, width of bearing plates, distance of bearing plate from the column edges, amount of lateral reinforcement, and ratio between horizontal and vertical components of applied loads.

It was found that bearing strength of column head is not directly proportional to the cylinder strength but to  $\sqrt{f_c}$  which is related to tensile strength of concrete.

The bearing strength of concrete is independent of column width if the bearing plate extends over the full width of column.

If the distance of load from edge of column is less than 1.5 inches, shear failure occurs; if the distance is more than 1.5 inches, splitting failure occurs.

Lateral reinforcement near the top of column prevents column splitting and shear if this force is applied at a distance larger than 1.5 inches from the free edge. The bearing strength of concrete is independent of lateral reinforcement for distance of less than 1.5 cm. For greater distance failure of column with lateral reinforcement will take place by crushing of concrete under the plate (Fig. 7).

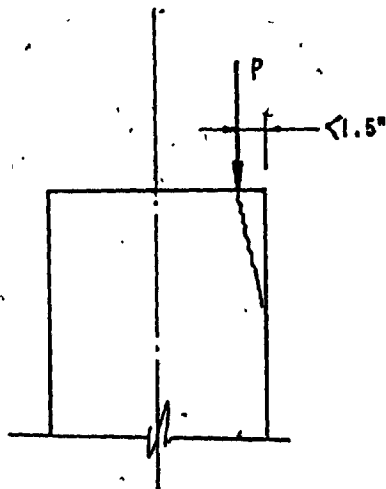

a) SHEAR FAILURE -- COLUMN HEAD WITH LATERAL REINFORCEMENT

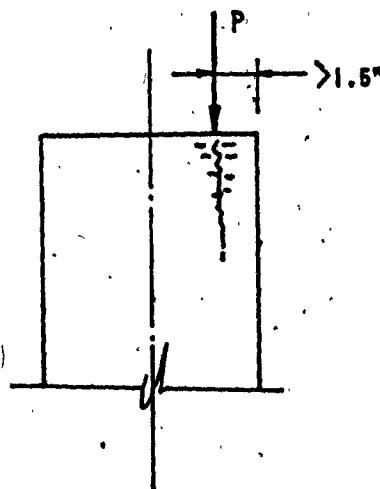

b) CRUSHING AND SPLITTING OF CONCRETE - COLUMN HEAD WITH LATERAL REINFORCEMENT

FIG.7 FAILURE OF COLUMNS

Increases of lateral reinforcement increase bearing capacity of column by up to 100% over the bearing strength of column heads without lateral reinforcement. The force transverse to the vertical load causes failure of concrete due to cracking and mainly bursting. If this bursting tensile force is arrested by use of sufficient amount of steel reinforcement at head level, the bearing capacity of concrete is increased.

The amount of lateral reinforcement corresponding to double capacity, which shall also be kept as maximum allowable in the design, is 0.16 sq. in. per inch of length of the bearing plate.

Yield strength of lateral reinforcing steel higher than 40,000 psi does not improve bearing strength of concrete. The anchorage of reinforcement and provision of confinement is very important and unless it is properly done, reinforcement will not fulfill the purpose. Figs. 8, 9 and 10 show examples of anchorage used.

The longitudinal reinforcement has no significant influence on column heads bearing capacity. The bearing capacity of column heads is reduced by horizontal forces. The reduction of strength depends on the ratio of the horizontal to vertical force and the width of the bearing plate.

The variables mentioned are included in the PCI code, but without sufficient credit given to lateral reinforcement of column heads. PCI test investigations allow to derive the design equations for

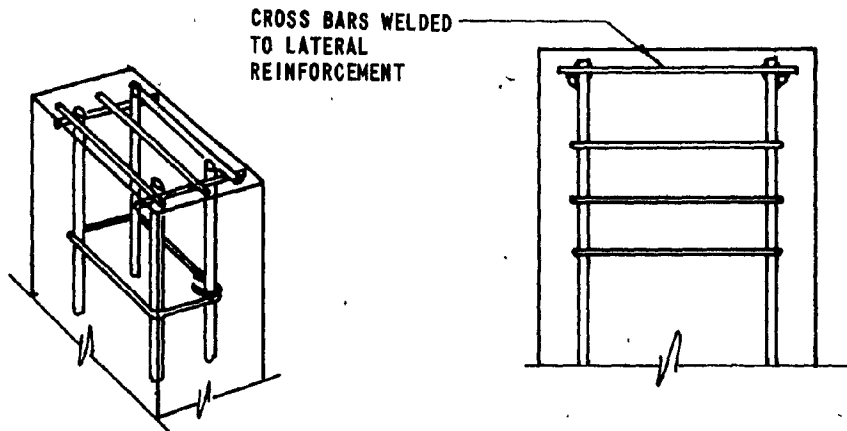

FIG.8 COLUMN HEAD LATERAL REINFORCEMENT

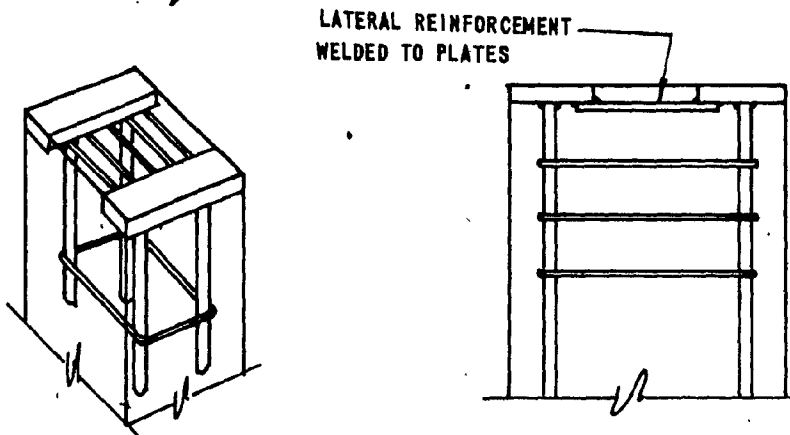

FIG.9 COLUMN HEAD LATERAL REINFORCEMENT

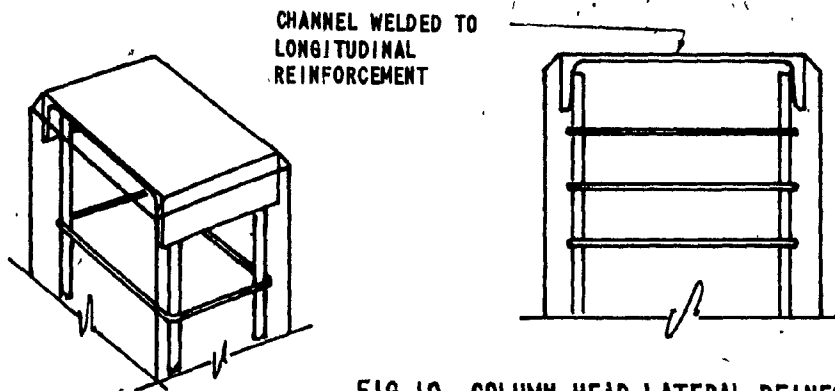

FIG.10 COLUMN HEAD LATERAL REINFORCEMENT

bearing capacity of column heads strengthened by lateral reinforcement. The equations are shown below for discussion. In the formula given, the second component in bracket represents the strength increase due to properly anchored reinforcement.

The ultimate bearing strength of concrete, according to (4) and (6):

$$f_{bu} = \phi \left[ 69 \sqrt{f_{c'}} \sqrt[3]{\frac{s}{w}} \right] \left[ 1 + C_1 \sqrt{\frac{A_{sl}}{b}} \right] \left[ \frac{C_2}{80} \right]^{\frac{H}{V}}$$

where:

$A_{sl}$  = Area of lateral reinforcement maximum  $f_y = 40,000$  psi

$b$  = Length of bearing plate, in.

$C_1$  = Constant = 0 when  $s < 2.0$  in  
2.5 when  $s > 2.0$  in or more

$C_2$  = The product  $sw$ , but not more than 9, in.<sup>2</sup>

$f_{c'}$  = Specified concrete compressive strength, psi.

$f_{bu}$  = Ultimate bearing strength of concrete, psi.

$\frac{H}{V}$  = Ratio of horizontal and vertical components of applied loads

$\phi$  = 0.85

$s$  = Distance from edge of column to centre line of bearing plate, in.

$w$  = Width of bearing plate, in.

The other recommendation is that the third component of the formula --

$\left[ \frac{C_2}{80} \right] \frac{H}{V}$  be used as:

$\left[ \frac{1}{16} \right] \frac{H}{V}$  - when the lateral reinforcement is welded to transverse reinforcement of equal size.

$\left[ \frac{1.7}{9} \right] \frac{H}{V}$  - when the lateral reinforcement is welded to embedded steel bearing plates or steel angles.

#### 4.0 EXAMPLES OF COLUMN CONNECTIONS

##### 4.1 Column to base Joints

There are few types of column-base connections commonly used in precast concrete structures. In general such connections can be classified by the degree of fixity achieved. In each case the stiffness of connections depends on plate deflection, bolt elongation and foundation rotation. Connections should be designed to transfer compressive forces, moments and shears. In the case of bolt moment connections, attention has to be paid to combined tension and shear force in the bolts.

In each type of connection provision has to be made for some means of vertical alignment and adjustment of column.

##### 4.1.1 Column to Base Socket type Connections

The type of socket connection shown in Figure 11 is usually levelled by the use of grout or accurately levelled steel shims. The lower part of the column is sometimes roughened to transfer part of the load to the foundations by friction rather than by end bearing only. Vertical column alignment during the erection is maintained by using temporary wood wedges driven between the socket and the column side.





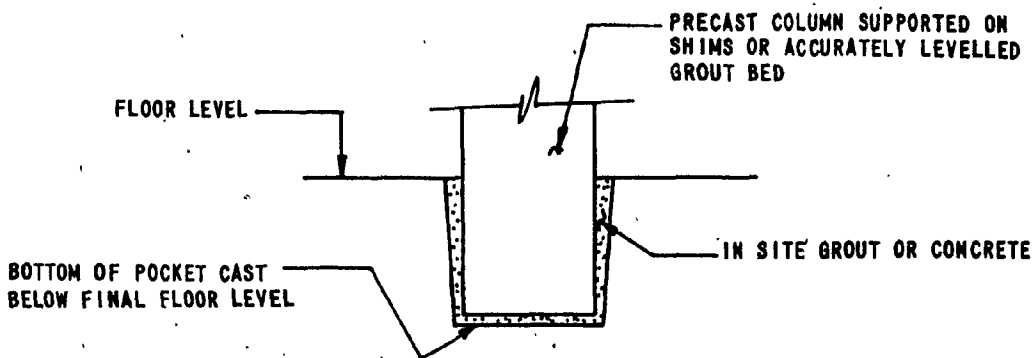

FIG. 11 COLUMN TO BASE SOCKET TYPE CONNECTION

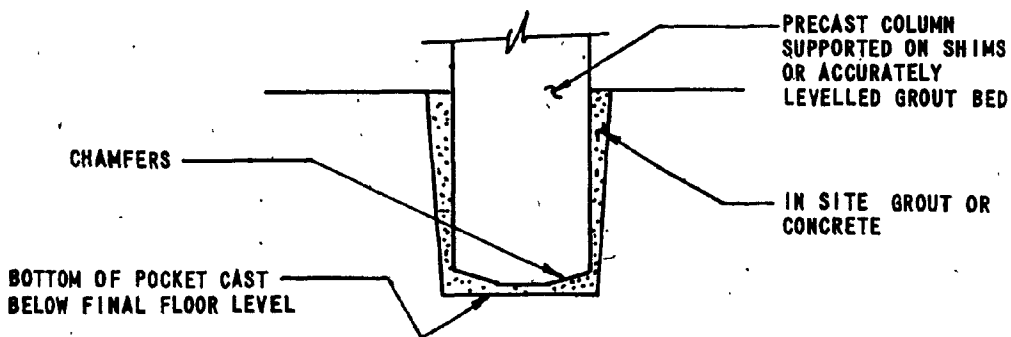

FIG. 12 COLUMN TO BASE SOCKET TYPE CONNECTION

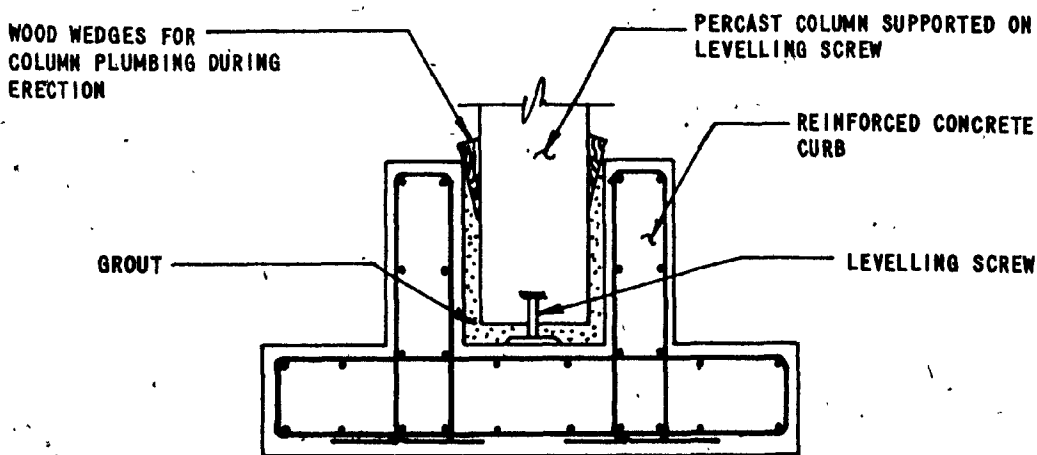

FIG. 13 COLUMN TO BASE SOCKET TYPE CONNECTION

Chamfers used in the base of the column (Fig. 12) improve the flow of grout or concrete into the gap beneath the column.

Reinforced concrete curb sockets (Fig. 13) increase the ability of the joint to resist the horizontal forces and at the same time care is taken of shrinkage of cast-in-situ concrete.

The socket type connections are suitable for columns which are too small to have a base plate, columns with a longer side of less than 9 inches. They are also practical for members with high moments and small vertical loads (poles). To develop the moment capacity of the column the socket depth should be the greater of a) the bond length of the column bars, or b) 1.5 times the longer side of the column.

#### 4.1.2 Column to Base Dowel type Connections

The detail in Fig. 14 represents a column with a large pocket which is filled with grout on site. Dowels set in the foundation engage the pocket and are bonded to the column by the grout. Reduction of column bearing strength could be expected unless very high compressive strength non-shrink grout is used. Temporary bracing during the erection is required. Fig. 15 shows a reversal of the scheme in which as the dowels are now part of the column and the socket is in the foundation. The column to column joint shown in Fig. 20 is based on the same principle.

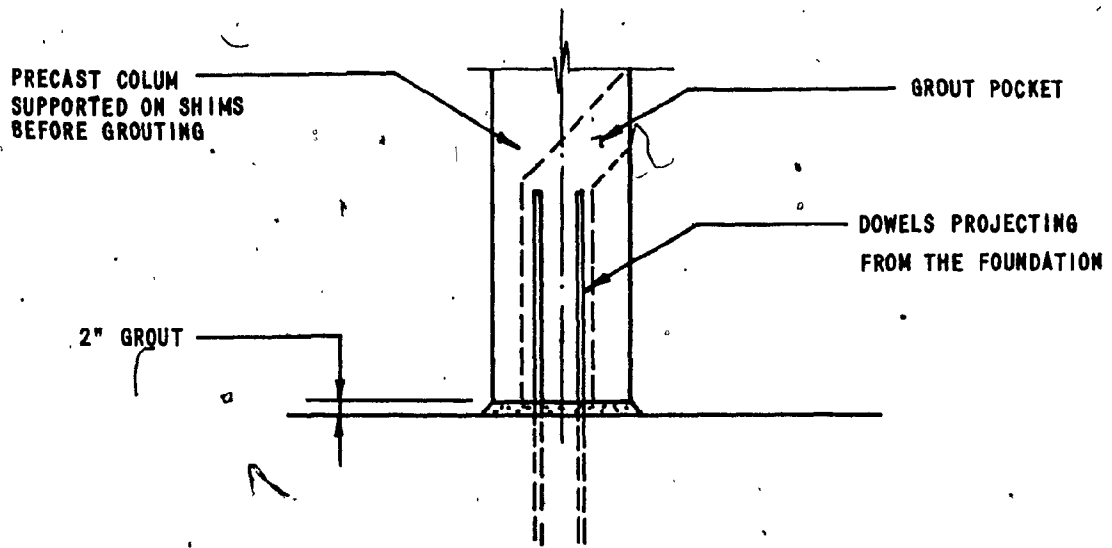

FIG. 14 COLUMN TO BASE DOWEL TYPE CONNECTION

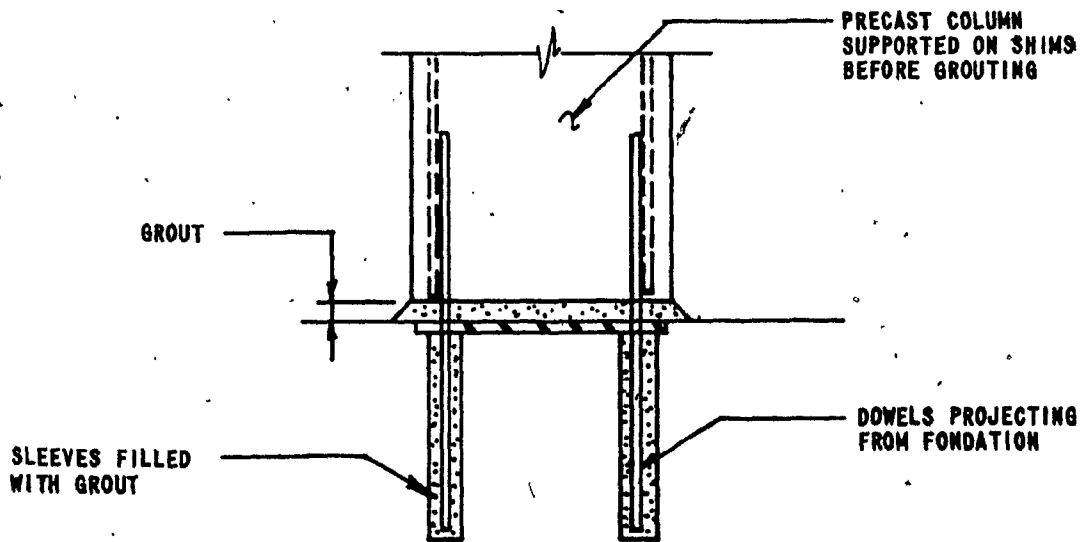

FIG. 15 COLUMN TO BASE DOWEL TYPE CONNECTION

#### 4.1.3 Column to Base - Base plate type Connections

Figures 16 and 17 illustrate the most popular and oldest type of connection used in prefabricated structures. The type shown in Fig. 17 is used for heavy loads with large moments. These connections allow for easy levelling and plumbing of columns, by means of shims or levelling screws. There should be a gap between the top of the footing and the bottom of the base plate for grouting.

Variations of base plate connections are used; some with pockets for anchor bolts or whole column connection recessed, and they will be illustrated when column to column connections are discussed.

#### 4.2.0 Column to Column Joints

A column-to-column joint is required when the height of a structure exceeds the length of column which can be precast in one piece, and also in a H-frame system. This applies to heights over 25 ft or any multi-story structure.

In precast rigid frame structures, bearing column-to-column connections should be located near points of contraflexure and consequently their effect on the frame should be negligible. Figures 1 and 2 indicate approximately the appropriate joint locations.

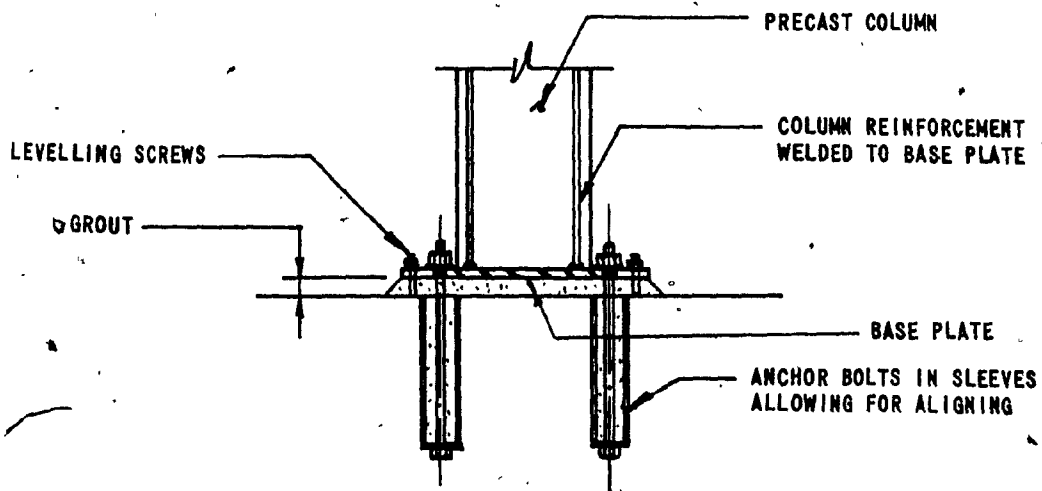

FIG.16 COLUMN TO BASE -- BASE PLATE TYPE CONNECTION

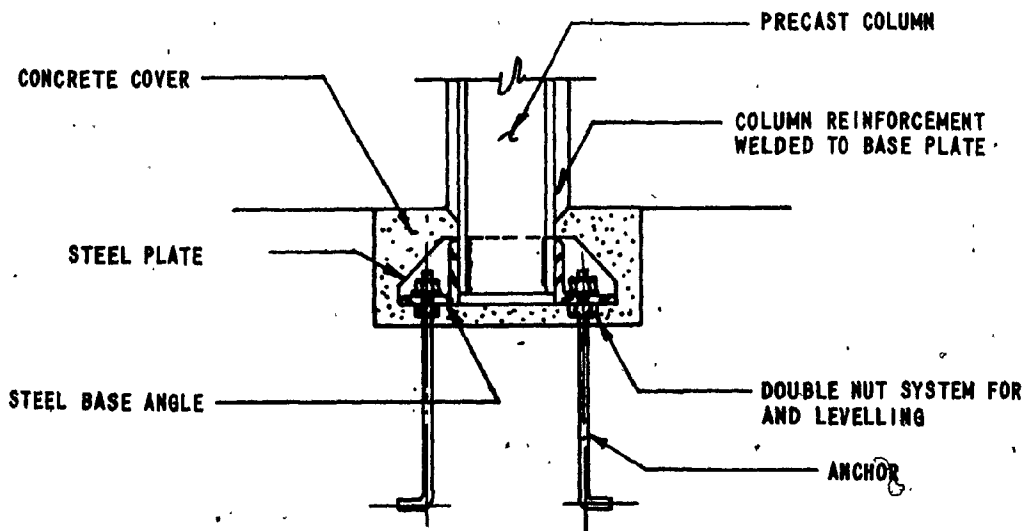

FIG.17 COLUMN TO BASE -- BASE PLATE TYPE CONNECTION

The following paragraphs illustrate and describe examples of column to column joints used in Canada and in other countries. Most of the joints shown have the capacity to transfer moments.

#### 4.2.1 Column to Column Base Plate Type Connections

Figures 18 and 19 show three types of connections with recessed or internal base plates extending partially or fully over the base. Anchor bolts are placed in pockets, reinforcing bars lapped and heads reinforced. The erection is similar to the one described before; levelling bolts and nuts are used. After erection recesses should be carefully grouted with high quality grout to assure full bearing capacity of column. If required, concrete cover for fire protection should be at least as thick as the concrete cover required for members. PCI describes the connections in detail.

#### 4.2.2 Column to Column Dowel Type Connections

In Figure 20 the principle used is the same as for the column to base dowel type connection. The only additional detail presented is temporary bracing used to stabilize the column during the erection. Often horizontal steel plates are placed on the bearing surface of columns and are welded to each other obviating the need for temporary bracing.

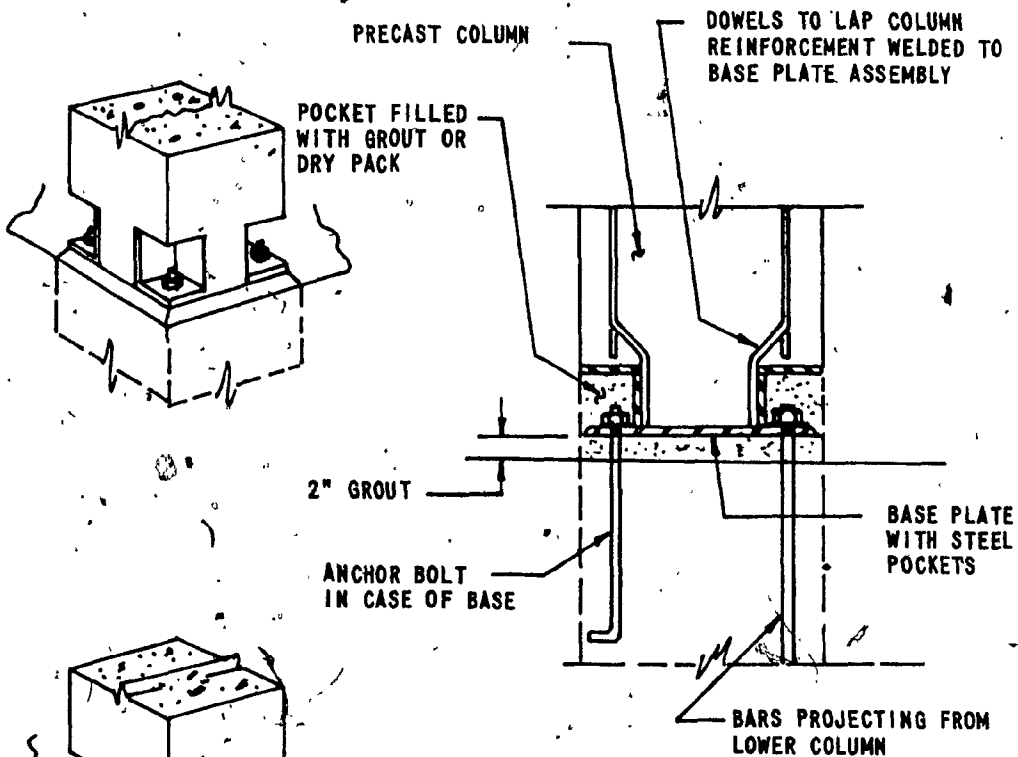

FIG. 18 COLUMN TO COLUMN RECESSED TYPE CONNECTION

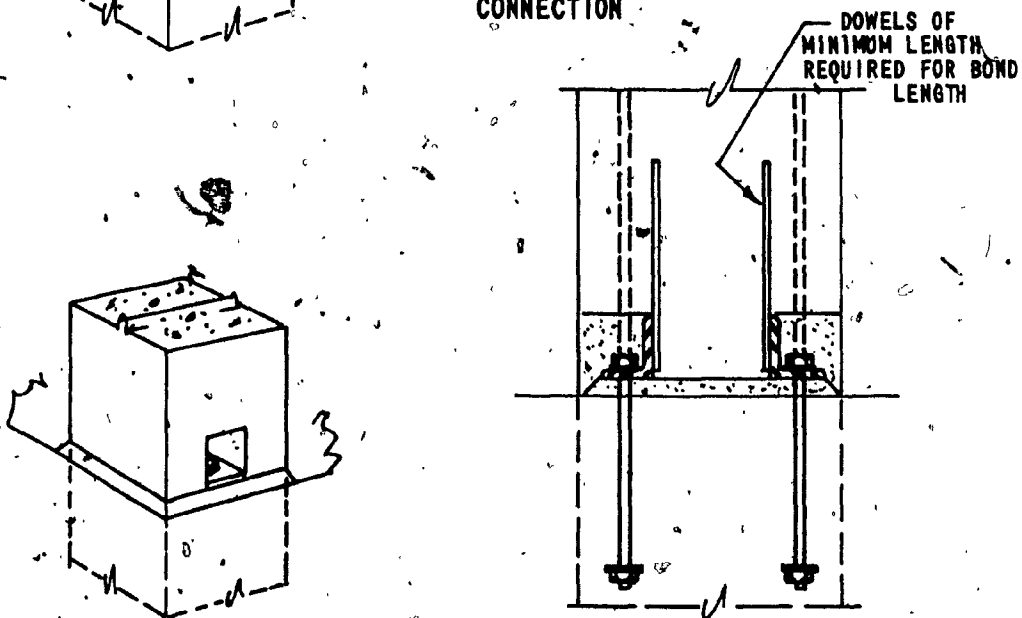
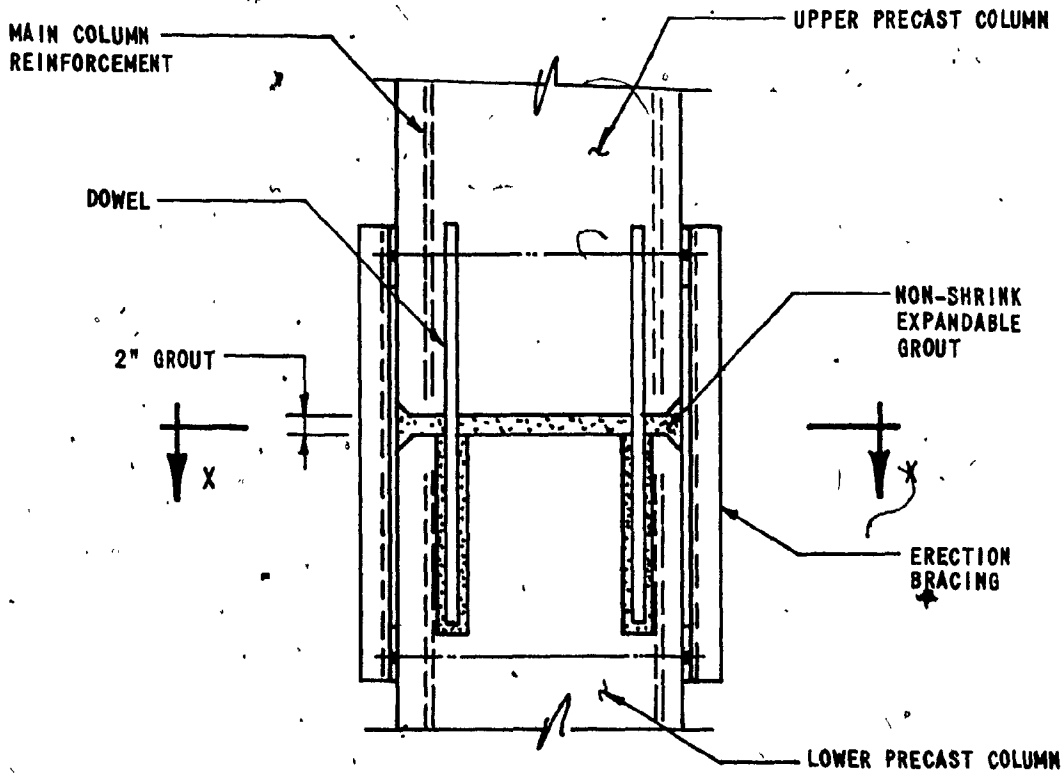

FIG. 19 COLUMN TO COLUMN RECESSED TYPE CONNECTION



ELEVATION

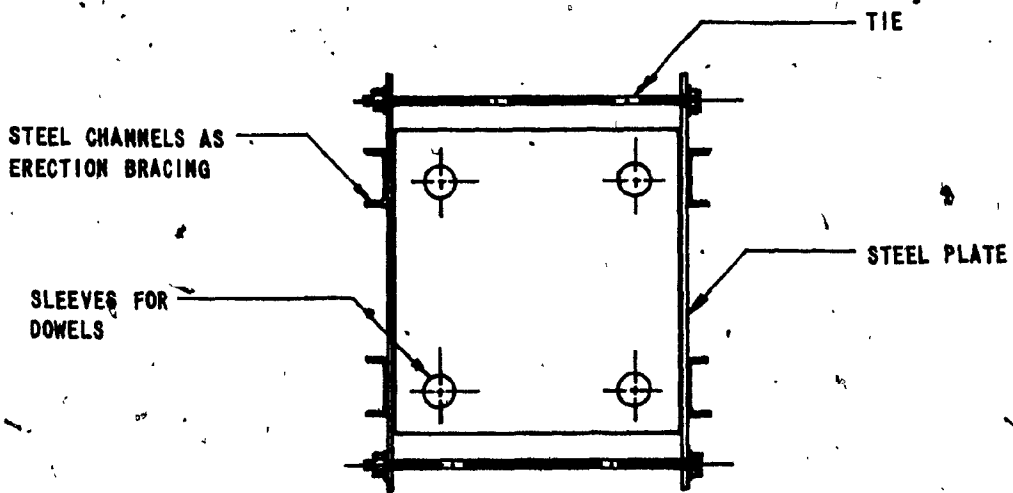

FIG.20 COLUMN TO COLUMN DOWEL TYPE CONNECTIONS



Figures 21 and 22 show dowel type connections. Mechanical means are used for levelling and plumbing. There is no need for temporary bracing only shims can be used additionally. The connections are capable of carrying some loads before space between columns is filled. While small pockets are introduced for turnbuckles and steel plates, the gap left should be the minimum required for the grout. Expandable or non-shrink grout should be used to assure full continuity in bearing. Heads of columns should be reinforced in accordance with the recommendations given earlier. Connections can transfer full vertical and shear loads and, to some degree moments.

#### 4.2.3 Column to Column Precision type Connections

Figures 23 and 24 present new concepts for column-column and column-base connections. The column in Figure 23, (8), has tapered steel spiggots on both ends which fit precisely into steel sockets at the joint. These joints can also be a part of a floor slab or part of a beam in which case the beam or floor slab reinforcing bars are threaded into the sockets, thus developing the full moment resistant of those members. Production and casting requires high accuracy, tolerances are very critical.

Figure 24 presents another type of precision connection. The principle is very similar to that already described, but in this case both column ends have sockets into which a pivot is fitted.

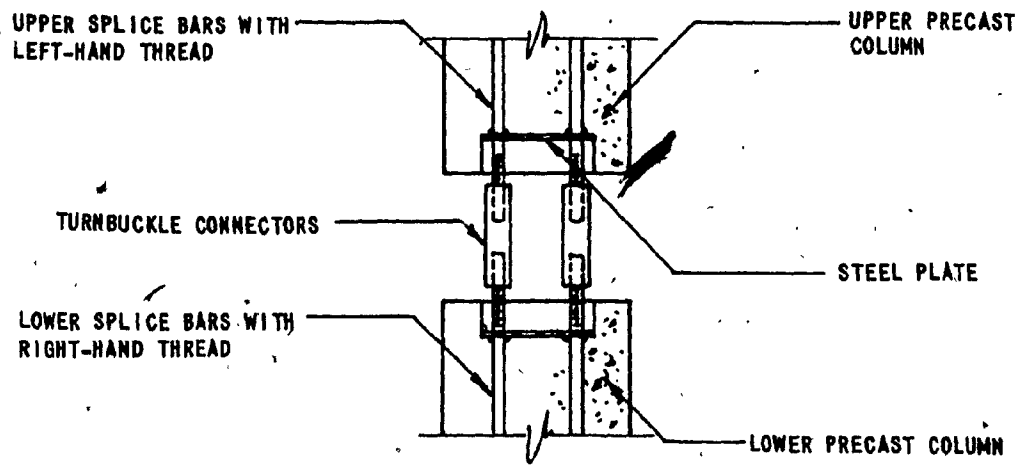

FIG. 21 COLUMN TO COLUMN DOWEL TYPE CONNECTION WITH TURNBUCKLE

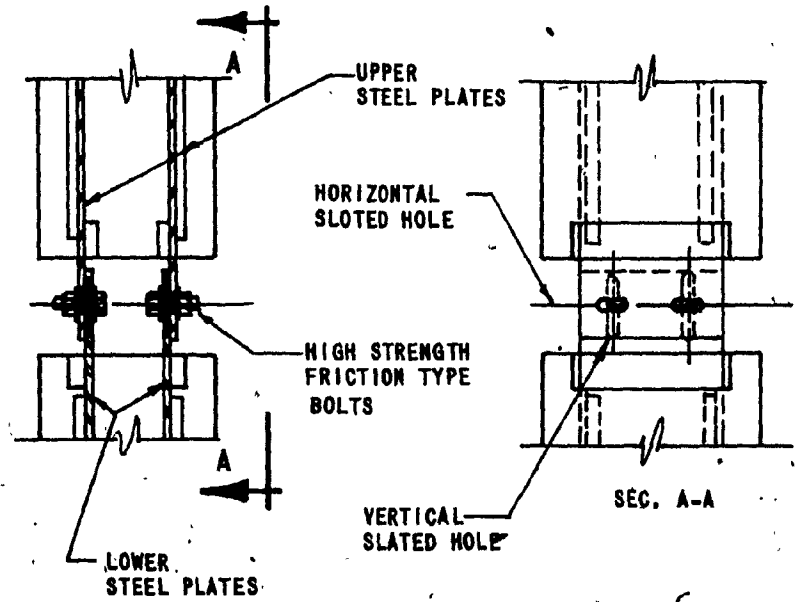

FIG. 22 COLUMN TO COLUMN DOWEL TYPE CONNECTION WITH STEEL PLATE

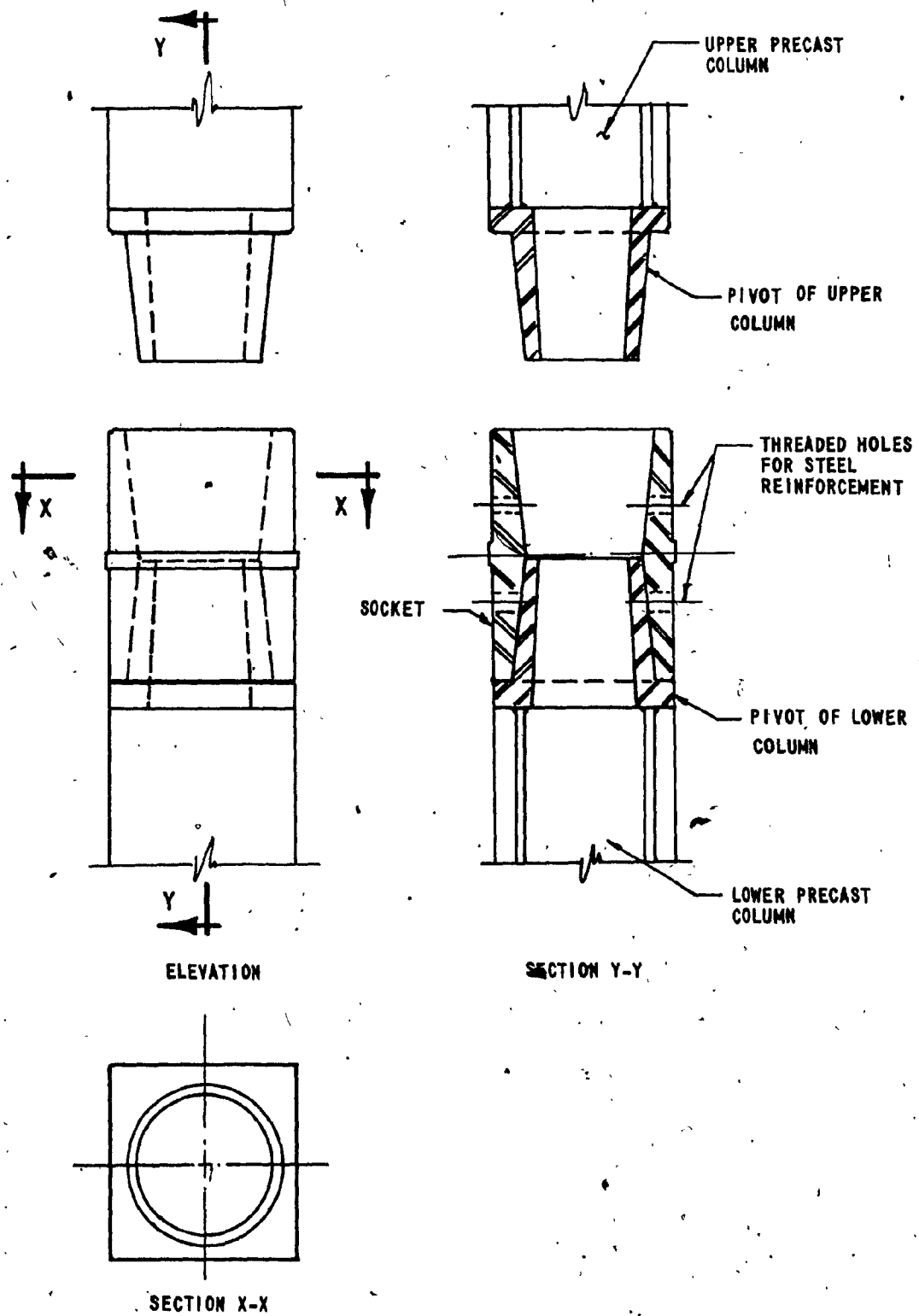

FIG. 23 COLUMN TO COLUMN PRECISION SOCKET TYPE CONNECTION

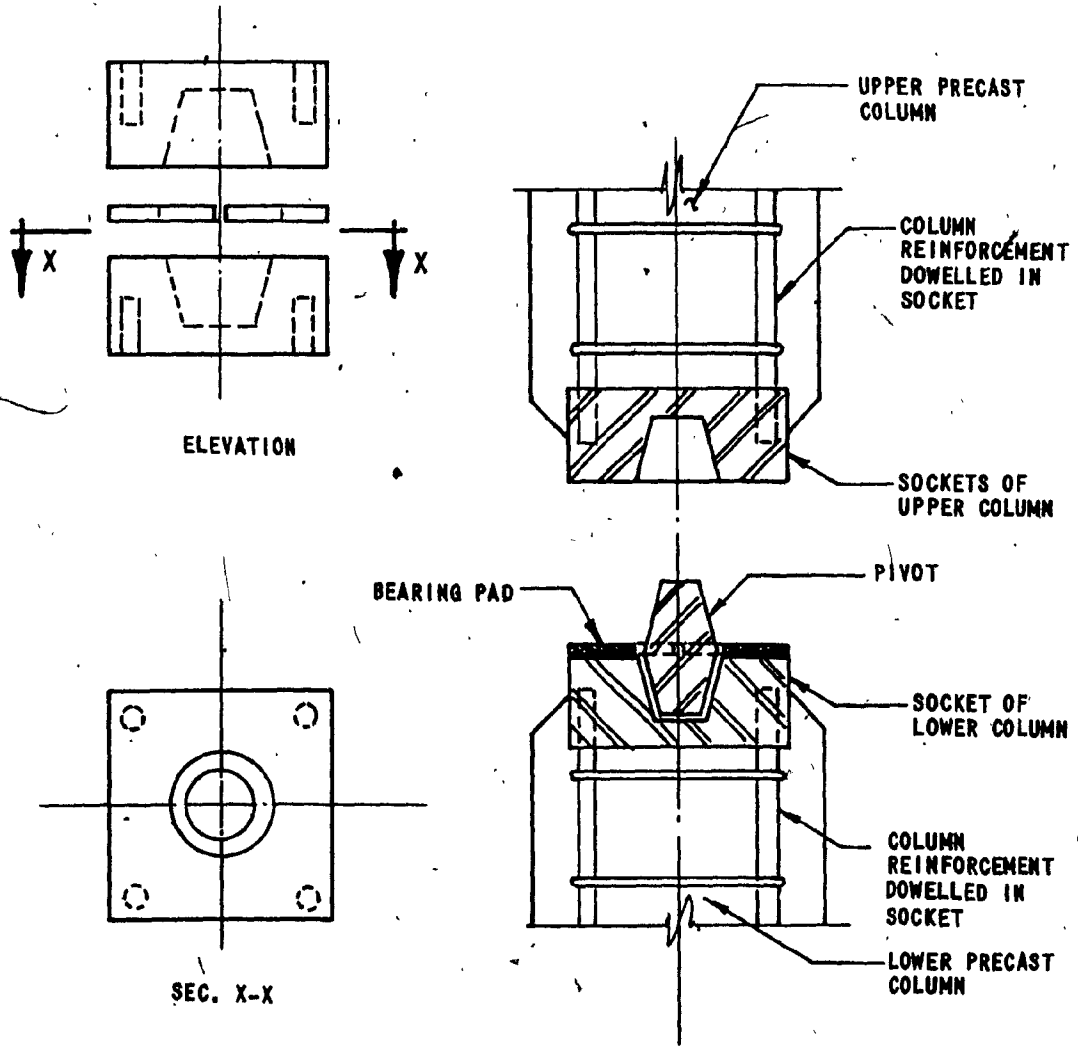

FIG.24 COLUMN TO COLUMN PRECISION-SOCKET TYPE CONNECTION

Although the connection requires precision in parts manufacture casting, the pivots, which are a separate loose part, and the bearing pads allow less strict tolerances during erection.

The precision type socket-spigot and socket-pivot joints can be mass produced and used as design forces and moments dictate; if necessary, for larger or odd shape columns, the joints can be used in multiples, two or more being welded to a common base plate.

Design of the socket joint is such that it allows for transfer of vertical loads, shears and in one case, moments. These joints can resist wind and earthquake forces. Erection is very simple and fast.

Figure 25 presents a bearing type column connections. The main connection components are: steel ring, steel circular plate and bolt which are assembled together to act as a shear key which absorbs horizontal forces but very little moment. The bolt also acts as a levelling screw for column alignment. Connection assemblies have to be accurately positioned in precast columns but this is easy since both top and bottom assemblies have anchors independent of column reinforcement. Connections can be mass produced in sizes dictated by the design forces. They are very suitable for H-type frames where connections are located at point of counterflexure.

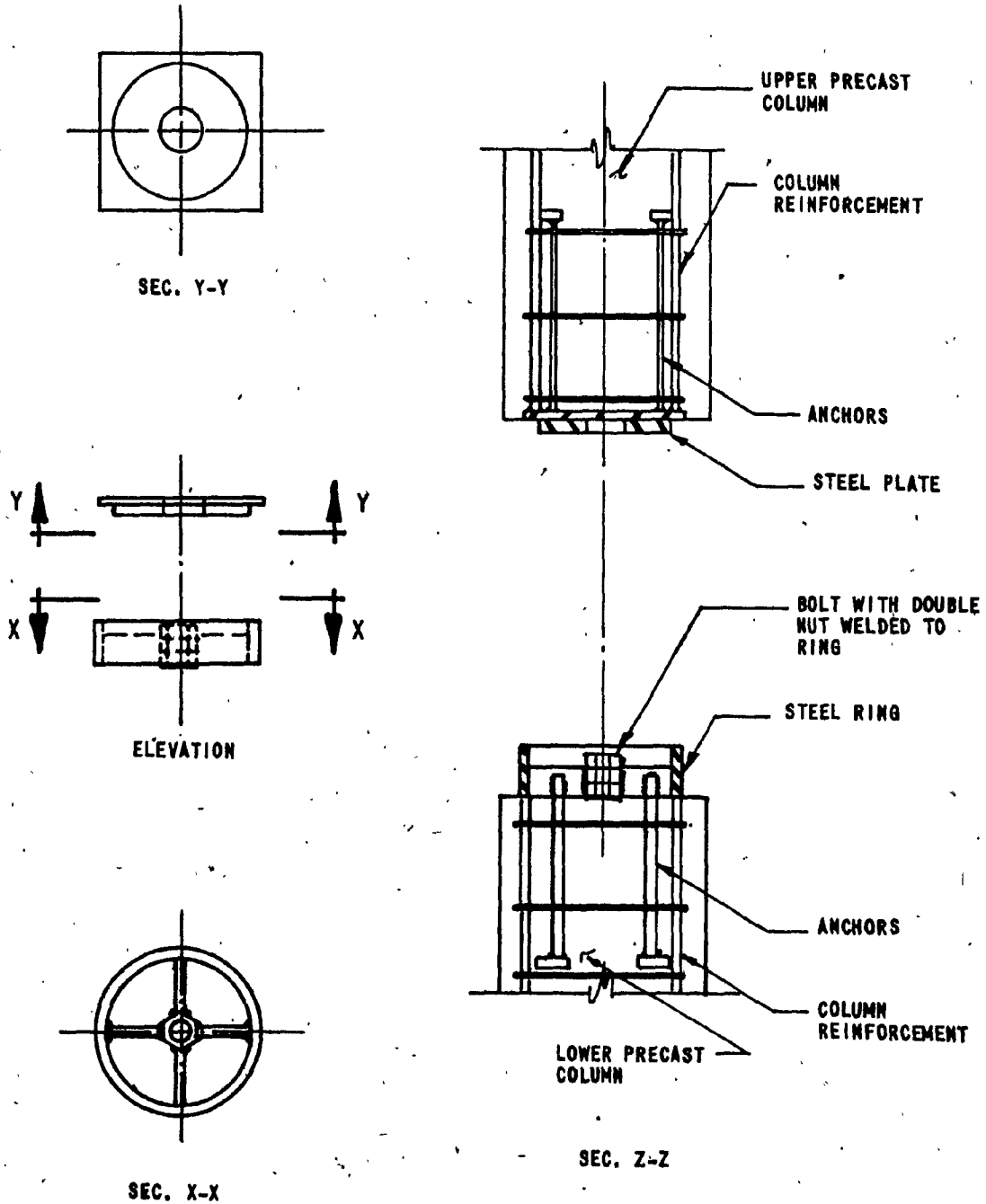
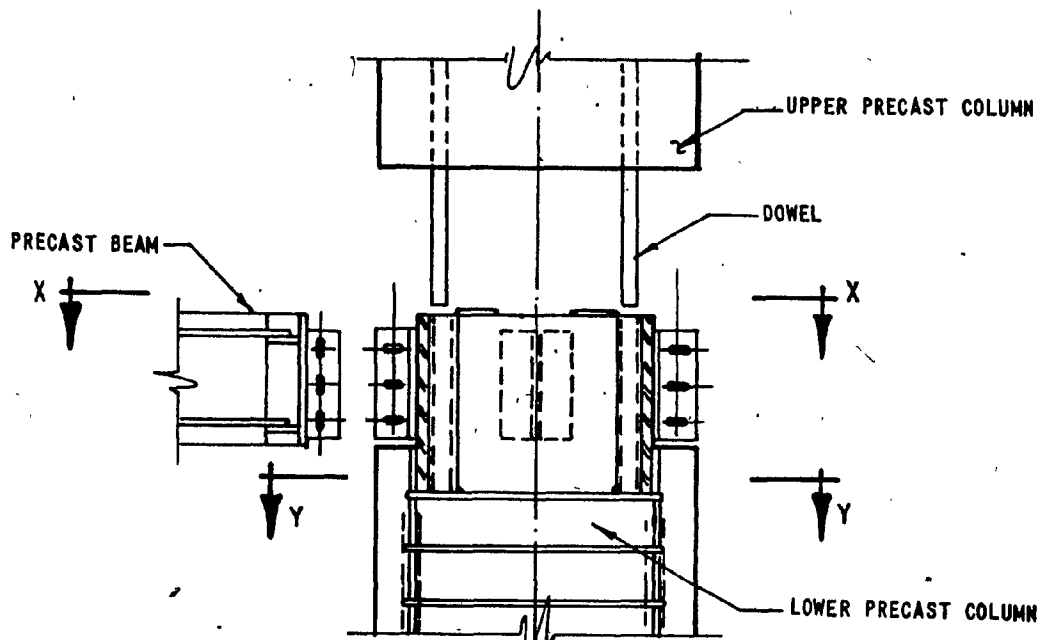

FIG. 25 COLUMN TO COLUMN PRECISION-KEY TYPE CONNECTION

Figure 26 is a suggested dowel type connection with provision for beam supports. Walls of standard square or rectangular hollow section, with angles or T-type sections welded on, can be used to receive the beams.

The bottom of this section is partially enclosed with steel plates serving as part of column head lateral reinforcement and as covers for dowel sleeves. The hollow steel section is filled with concrete during precasting. After erection sleeves and gap between columns shall be filled with grout. Fire protection cover shall be used if required.



ELEVATION

BEAM SUPPORTS

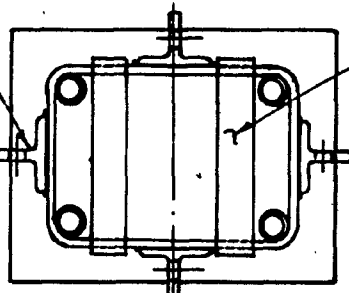
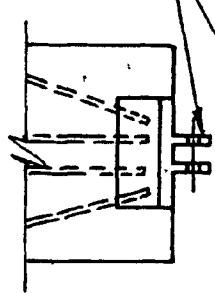

SEC. X-X

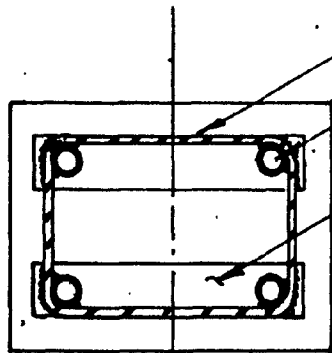

SEC. Y-Y

FIG. 26 COLUMN TO COLUMN DOWEL TYPE CONNECTION WITH BEAM SUPPORTS



## 5.0 CONCLUSIONS

The surveyed examples of joints published by PCI, the manufacturers, users and designers show that very few types of bearing column connections are available on the market.

Moment type connections with various degrees of rigidity are the principal type in use. From references, technical descriptions and design data it can be seen that the development of connections has been carried out by engineers or contractors for specific structures, subjected to particular systems of forces.

There is no general design procedure available. Design is very specific due to the complex character and behaviour of connections and, to a large extent, depends on the good practical experience and judgement of the engineer.

There is not enough information on the strength and ductility of joints and connections, especially between dissimilar members such as columns, slabs, walls and beams.

In the analysis of prefabricated structures it is important to assess correctly the load transfer efficiency and the structural continuity available at the connections. As this avoids unrealistic stress distributions in design, the use of a systematic experimental investigation of efficient and practical

connection types could lead to more rational design procedures for building structures assembled from precast components.

Experiments carried out so far were of a sporadic nature. It would be very desirable to perform more systematic studies and tests as these could lead to improved and more general design procedures.

Complexities arise when the over-all equilibrium of box-like structures is investigated. Models should be used to elucidate the problems: two-dimensional models and for more complex system, three-dimensional models. The model studies could throw light on the stability of structures as a whole under vertical and horizontal load effects, as well as on the state of stress in individual members and in their connections.

Model tests could lead to the establishment of uniform safety factors and to a better definition of stress problems related to dynamic and earthquake effects.

Correlation between model tests and analytical methods would result in improved design procedures.

APPENDIX I- REFERENCES

1. "PCI - Manual on design of connections for precast prestressed concrete", prepared by PCI Committee on connection details (1970-1972), Publisher; Prestressed Concrete Institute 1973.
2. "Precast Concrete Handling and Erection", by Joseph J. Waddell. Publisher; The Iowa State University Press AMES, Iowa; American Concrete Institute, Detroit, Michigan, 1974.
3. "Canadian Prestressed Concrete Institute -- Handbook", by Cazaly and Huggins. Publisher; Canadian Prestressed Concrete Institute, Toronto, 1964.
4. "Modern Prestressed Concrete - Design Principles and Construction Methods", by James R. Libby. Publisher; Van Nostrand Reinhold Company, Toronto, 1977.
5. Fifth International Congress of the Precast Concrete Industry, London 21 to 27 May, 1966.
6. "Bearing Strength of Concrete -- Geometric Variations", by S.K. Niyogi, from the "Journal of the Structural Division" July 1973. Vo. 99, S. 7

APPENDIX I- REFERENCES (Continued)

7. "Connections in Precast Concrete Structures -- Bearing Strength of Column Heads", by L.B. Kriz and C.H. Raths from the "Journal of the Prestressed Concrete Institute" December 1963. Vol. 8, No. 6.
8. "Universal Precision Structures", by Oscar Singer, Mg. Arch. Griba, Ch. Arch, and Jan Bobrowski, B. Sc. Mice, Struct. Eng. Consultant.
9. "Design of Prestressed Concrete", by S.C.C. Bate and E.W. Bennett. Publisher; Surrey, University Press-London, 1976.
10. "Design of Prestressed Concrete", by A. Hartland. Publisher; Surrey, University Press-London, 1975.

APPENDIX II - NOTATIONS

The following symbols are used in this report:

- A - Exposed area of structural member,  $ft^2$ .
- $A_{ch}$  - Area of horizontal confinement reinforcement,  $in.^2$ .
- $A_{cv}$  - Area of vertical confinement reinforcement,  $in.^2$ .
- $A_{sl}$  - Area of lateral reinforcement,  $in.^2$ .
- $A_{sh}$  - Area of reinforcement for horizontal cracks,  $in.^2$ .
- $A_{vf}$  - Area of shear friction reinforcement,  $in.^2$ .
- b - Length of bearing plate, in.
- $f_{bu}$  - Ultimate bearing strength of concrete, psi.
- $F_{bst}$  - Tensile bursting force, lb.
- $f_c$  - Specified compressive strength of concrete, psi.
- $f_y$  - Specified yield strength of reinforcement, psi.
- $f_{sh}$  - Yield strength for  $A_{sh}$ , psi.
- $f_{yv}$  - Yield strength for  $A_{vf}$ , psi.
- P - Ultimate load on connection, lb.
- s - Distance from free edge to center of bearing, in.
- $T_u$  - Ultimate tensile force acting with  $V_u$ , lb.
- V - Wind velocity, mph.
- $V_u$  - Ultimate shear applied on the connection, lb.
- W - Width of bearing plate perpendicular to free edge, in.
- $Y_o$  - Half width of concrete end block, in.
- $Y_{po}$  - Half width of bearing plate of concrete end block, in.
- $\mu$  - Shear friction coefficient

APPENDIX III - LIST OF FIGURES

Following figures are included in this report:

- Fig. 1 Portal frame structures moments due to horizontal force
- Fig. 2 Multy storey frame structures moments due to horizontal force
- Fig. 3 Structures with rigid frames
- Fig. 4 Structures composed of rigid frames
- Fig. 5 Bearing on plain concrete (PCI)
- Fig. 6 End block bursting tensile force post-tensioned concrete analogy
- Fig. 7 Failure of columns
- Fig. 8 Column heads lateral reinforcement
- Fig. 9 Column heads lateral reinforcement
- Fig. 10 Column heads lateral reinforcement
- Fig. 11 Column to base socket type connection
- Fig. 12 Column to base socket type connection
- Fig. 13 Column to base socket type connection
- Fig. 14 Column to base dowel type connection
- Fig. 15 Column to base dowel type connection
- Fig. 16 Column to base-base plate type connection
- Fig. 17 Column to base-base plate type connection
- Fig. 18 Column to column recessed type connection
- Fig. 19 Column to column recessed type connection
- Fig. 20 Column to column dowel type connection
- Fig. 21 Column to column dowel type connection

- Fig. 22 Column to column dowel type connection
- Fig. 23 Column to column precision - socket type connection
- Fig. 24 Column to column precision - socket type connection
- Fig. 25 Column to column precision - key type connection
- Fig. 26 Column to column dowel type connection with beam supports