



National Library  
of Canada

Acquisitions and  
Bibliographic Services Branch

395 Wellington Street  
Ottawa, Ontario  
K1A 0N4

Bibliothèque nationale  
du Canada

Direction des acquisitions et  
des services bibliographiques

395, rue Wellington  
Ottawa (Ontario)  
K1A 0N4

Notice - Notice

AVIS - Avis

## NOTICE

The quality of this microform is heavily dependent upon the quality of the original thesis submitted for microfilming. Every effort has been made to ensure the highest quality of reproduction possible.

If pages are missing, contact the university which granted the degree.

Some pages may have indistinct print especially if the original pages were typed with a poor typewriter ribbon or if the university sent us an inferior photocopy.

Reproduction in full or in part of this microform is governed by the Canadian Copyright Act, R.S.C. 1970, c. C-30, and subsequent amendments.

## AVIS

La qualité de cette microforme dépend grandement de la qualité de la thèse soumise au microfilmage. Nous avons tout fait pour assurer une qualité supérieure de reproduction.

S'il manque des pages, veuillez communiquer avec l'université qui a conféré le grade.

La qualité d'impression de certaines pages peut laisser à désirer, surtout si les pages originales ont été dactylographiées à l'aide d'un ruban usé ou si l'université nous a fait parvenir une photocopie de qualité inférieure.

La reproduction, même partielle, de cette microforme est soumise à la Loi canadienne sur le droit d'auteur, SRC 1970, c. C-30, et ses amendements subséquents.

Canada

**Design, Development, Production and Evaluation of a  
Computer-based Multimedia Application to teach  
Number Concepts to Intellectually Disabled Children**

Claude André Poirier

A Thesis  
in  
The Department  
of  
Education

Presented in Partial fulfilment of the Requirements  
for the Degree of Master of Arts at

Concordia University  
Montreal, Quebec, Canada

April 1994

© Claude André Poirier, 1994



National Library  
of Canada

Acquisitions and  
Bibliographic Services Branch

395 Wellington Street  
Ottawa, Ontario  
K1A 0N4

Bibliothèque nationale  
du Canada

Direction des acquisitions et  
des services bibliographiques

395, rue Wellington  
Ottawa (Ontario)  
K1A 0N4

*Voici le titre de votre thèse*

*C'est le titre de votre thèse*

**The author has granted an irrevocable non-exclusive licence allowing the National Library of Canada to reproduce, loan, distribute or sell copies of his/her thesis by any means and in any form or format, making this thesis available to interested persons.**

**L'auteur a accordé une licence irrévocable et non exclusive permettant à la Bibliothèque nationale du Canada de reproduire, prêter, distribuer ou vendre des copies de sa thèse de quelque manière et sous quelque forme que ce soit pour mettre des exemplaires de cette thèse à la disposition des personnes intéressées.**

**The author retains ownership of the copyright in his/her thesis. Neither the thesis nor substantial extracts from it may be printed or otherwise reproduced without his/her permission.**

**L'auteur conserve la propriété du droit d'auteur qui protège sa thèse. Ni la thèse ni des extraits substantiels de celle-ci ne doivent être imprimés ou autrement reproduits sans son autorisation.**

ISBN 0-315-90877-7

**Canada**

## Abstract

Design, Development, Production and Evaluation of a  
Computer-based Multimedia Application to teach  
Number Concepts to Intellectually Disabled Children

Claude André Poirier

Using computers in education has had appreciable support over the years. Although many programs have been developed with special needs students in mind, the majority of commercially available software is developed for the general education market. Because adaptation of educational software cannot be done as easily as it can with teaching materials, which is often required in special education, special software needs to be developed to address compelling needs of intellectually disabled children. Here, interactive multimedia is proposed to promote independence, academic skills and teacher usability, while providing an entertaining learning experience for students. The design of the software included consultations with psychologists, speech pathologists, occupational therapists, and special education teachers. Multimedia Numbers was developed to teach number concepts to intellectually disabled children, using a unique approach. The software offers digitized speech in English and French, with the option of a male or female voice for teaching, prompting, and feedback. The program provides an intuitive interface, specifically designed for teachers.

Important considerations in researching authoring software, selecting the appropriate computer platform, and distribution possibilities of a finished product are discussed.

## **Acknowledgements**

To the special education teachers, consultants and paramedical specialists of Summit School, thank you for sharing your knowledge and experience.

## Dedication

To my wonderful wife, Marie, for her remarkable support  
in all my endeavours over the last few years.

## TABLE OF CONTENTS

List of illustrations . . . . .	ix
List of tables . . . . .	x
Introduction . . . . .	1
Problems in perspective . . . . .	4
Target Population . . . . .	6
Objectives . . . . .	8
Rationale . . . . .	9
A Multimedia Solution . . . . .	9
Literature Review . . . . .	12
Strategies for teaching number skills . . . . .	14
Limitations of existing software . . . . .	18
Design . . . . .	21
Teaching Strategy . . . . .	21
Putting the strategy on the screen . . . . .	23
Testing the concepts on the computer . . . . .	27
Special considerations in design . . . . .	33
Contacts with experts . . . . .	34
Designing the user interface . . . . .	36
User interface issues regarding teachers . . . . .	37
Researching authoring systems . . . . .	41
Computer platform selection . . . . .	42
Development . . . . .	45
Production tools . . . . .	45
Methodology . . . . .	46
Problems encountered during development . . . . .	48
Evaluation . . . . .	50
Student evaluation . . . . .	50
Results of the student evaluation . . . . .	54
Teacher evaluation . . . . .	60
Discussion and recommendations - teacher evaluation . . . . .	61
Distribution possibilities . . . . .	64
Conclusion . . . . .	65
Appendix	



A. Pretest data collection sheet . . . . .	68
B. Posttest data collection sheet . . . . .	69
C. Numbers used for pretest and posttest . . . . .	70
D. Notes on student - data sheet . . . . .	71
E. Teacher Evaluation - data sheet . . . . .	72
F. Teacher Evaluation - actual data sheets . . . . .	73
Bibliography . . . . .	74

## LIST OF ILLUSTRATIONS

Figure	Page
1. Rote counting to numeral recognition.....	23
2. Sequential positioning to numeral recognition.....	24
3. Numeral association to groups of objects.....	25
4. Forming groups of objects with a split screen.....	26
5. Touch counting at random.....	27
6. Starting screen - numeral recognition test.....	28
7. Recognition testing - positive feedback.....	29
8. Recognition testing - corrective feedback.....	29
9. Starting screen - counting test.....	31
10. Positive feedback - counting test.....	32
11. Corrective feedback - counting test.....	32
12a. Interface flowchart (part A).....	39
12b. Interface flowchart (part B).....	40
13. Interface Main Menu.....	47

## LIST OF TABLES

Table	Page
1. Numeral recognition pretest and posttest data.....	58
2. Touch counting pretest and posttest data.....	58
3. Summary table - Analysis of variance numeral recognition.....	59
4. Summary table - Analysis of variance touch counting.....	59

## **Introduction**

In September of 1991 I began working as a computer consultant at a very special school for the intellectually disabled, called Summit School. The School's primary objective is to help all of its' 310 students reach their full potential. Aged between 4 and 21, the students are entered into one of four educational programs: Early childhood; Functional; Academic; or Vocational (Job integration).

As head of the computer department, a component of my functions involves researching and evaluating educational software, based on objectives set by the teachers for their students. Out of the 32 classes which form the School, approximately 140 students use the computer, either for reinforcement of academic skills, job training, or simply recreation (action/reaction and/or arcade-type games).

Most of the students in the early childhood program (ages 4 - 7), as well as some younger students from the functional program (ages 8 -12), use the computer as a tool to teach and reinforce number skills.

Being part of everything that surrounds us throughout our lives, numbers are unavoidable. Starting from the first year of our life, one engages in a long course which will lead us to number concepts. The discovery process is ignited with our first birthday, and soon after we learn to recite

numeral names by rote without any meaning. Then the use of our fingers becomes important as we begin to point and start counting. As we accumulate experiences with numbers, we learn to compare, order, classify, and so on.<sup>1</sup>

Numbers have been the fascination and the torment of many people for centuries. Surprisingly enough, a large number of people of all ages have difficulty understanding how they work. This difficulty is even more apparent with intellectually disabled children.

Using computers in education has had tremendous support over the years. As was established by Griswold (1984)<sup>2</sup>, computer assisted instruction for students in the elementary school setting helps develop a stronger sense of academic self-confidence and a greater sense of personal responsibility for success. This impression was found to be particularly strong for educationally disadvantaged children.

Computers have been used in special education for many years and myriad software have been developed to teach number concepts.

Massey & Gelormino (1987)<sup>3</sup>, who looked at the influence

---

<sup>1</sup>Marie-Michèle Tousignant, "Paper presented to Jean-Marie Labrie" (University of Sherbrooke, 1990) 2-11.

<sup>2</sup>P.A. Griswold "Elementary Students' Attitudes During Two Years of Computer Assisted Instruction" in Research Windows - CAI Increases Academic Self-Confidence, ed. Betty Collis (Enschede: University of Twente, 1985), 23.

<sup>3</sup>C. Massey, J. Gelormino, "The influence of a math software on preschoolers' acquisition of mathematics: 'Rutons' in the classroom" in Research Windows - Preschoolers and Mathematics Software, ed. Betty Collis (Enschede: University of Twente, 1986), 70-71.

of a math software on preschoolers' acquisition of mathematics, found that children with access to computers had significantly greater score gains on number concepts tests than those without access. Furthermore, they concluded that young children who have low level mathematic achievement can be comfortable and independent using math software and can benefit from the interaction.

Although some programs have been developed with the special needs student in mind, the majority of programs are developed for the general public. Since many of educational materials used in special education were not made specifically for the intellectually disabled, having to adapt teaching materials in special education is common practise. For an experienced teacher, this can be a relatively simple task. If a method of teaching appears to be ineffective, a modification of the materials following analysis could do the trick for one particular student.

It is not surprising that the same problem is present in educational software. With software, however, adaptation is difficult because the source codes are not available for modification.

Finding the appropriate level when working with a software is usually not a problem. Based on the objectives set for a particular student, a series of programs are tried until the appropriate level is found.

From an economic perspective, buying every math software

until one finds the appropriate method, level, and pace of presenting a concept is not feasible.

### **Problems in perspective**

Classrooms in primary schools usually have between 20 and 30 students, and one teacher. Special education classes at Summit School, however, may have 8 to 10 students, one teacher, and one or two teaching assistants (Note: this does not include regular classes with integrated students). It is evident that the level of individual attention required is greater with intellectually disabled students (i.e. special needs). This is where part of the problem arises.

In special education, the variety of behaviours and learning strategies of the children make traditional classroom teaching arduous. Motivation of the students is the primary determinant of success. The learning curve of each student is so distinct that one-to-one tutoring is more than often required, but not always possible. When one-to-one tutoring is not possible (often 1-to-2 or 1-to-3), the challenge for the teacher in a special education classroom setting is to create a motivating learning environment for all students at the same time. A prominent difficulty with young learning-disabled children is lack of focus on task. As a result, students are very easily distracted, and the motivation aspect becomes a vital contributing factor to learning, especially with the

characteristics of the target population.

Many of the various software packages that are available today still forget to address an important concern in education, namely, independence. In 1985, a survey of all school districts of Oregon (Thorman & Gersten, 1985)<sup>4</sup> indicated that special education teachers rarely used computers to teach new concepts. Even though the computer was found to be a good motivator which boosted self-esteem, the main problem was the time of exposure to the computer. If every program requires that a teacher give assistance, it becomes obvious that teachers have no time to work with all students.

If part of the overall problem is the need for one-to-one tutoring, which is, most unfortunately, difficult to provide, then one objective should be to allow the motivating element to serve as an independent tool for learning.

---

<sup>4</sup>J. Thorman, R. Gersten, "Microcomputer Use in Special Education : An Empirical Investigation of Teachers' Perception." in Research Windows, ed. Betty Collis (Enschede: University of Twente, 1985), 23.



## **Target Population**

In traditional instructional design, one would like to define the target population as relatively homogeneous. However, in this project, this was not possible because of the variety of intellectual capabilities, and the range of disorders and behaviours of the students. The students from the target population may suffer from a variety of mental disorders, physical and/or sensory difficulties, and may have one or more of the following characteristics: low attention span (unfocused at task); emotional and behavioral disturbances; abusive behaviour; low visual tracking; developmentally or globally delayed; autistic; trisomic (down's syndrome); fragile X syndrome; non-verbal; hearing impaired; and other forms of mental retardation and/or communication disorders.

Although the proposed product could be used by mainstream children, the primary target population are intellectually disabled children aged between 4 and 7 years (mental and real age), being taught in an English or French environment. Note that the term "Intellectually disabled" cannot be generalized in terms of behaviour and/or learning ability.<sup>5</sup> This is also true for any regular education classroom child, in that every student has distinct behaviours and learning abilities, which explains much of the

---

<sup>5</sup>Herman Erdogmus, Interview by André Poirier, 7 January 1993, Montreal, Qc.

disparity in student performance (grades) and conduct.

Over the past two years, two common characteristics among many of the children of the target population have been observed, and should be mentioned: students generally don't like to be helped by the teacher, and usually want to work alone (don't like sharing). Some students even ask to work by themselves. If the same students have a partner to work with imposed on them, they tend to take over the computer and repeatedly need to be told to share. The children love to use the computer and will do so every opportunity they get.

Harper and Ewing (1986)<sup>6</sup> found that students preferred the computer to the traditional workbook because they felt they learned more. Perhaps this is also the case with this population. Swigger & Swigger (1984)<sup>7</sup> observed a different phenomenon with regular stream preschoolers, where children persisted to go to the computer in groups of two or three (usually close friends) but only one child was the operator while the others watched. Furthermore, it was observed that not all children would automatically want to use the computer when available. With respect to teacher intervention when using the computer Goodwin et al (1986)<sup>8</sup> found that only 11

---

<sup>6</sup>J.A. Harper, N.J. Ewing, "A comparison of the effectiveness of microcomputer and workbook instruction on reading comprehension performance of high incidence handicapped children." in Research Windows - Learning disabilities and CAI, ed. Betty Collis (Enschede: University of Twente, 1986), 44.

<sup>7</sup>K.M. Swigger, B.K. Swigger, "Social patterns and computer use among preschool children," in Research Window - Group vs. Individual Computer Use: Preschool Children's Preferences, ed. Betty Collis (Enschede: University of Twente, 1986), 37.

<sup>8</sup>L.D. Goodwin, W.L. Goodwin, A. Nansel, C.P. Helm "Cognitive and affective effects of various types of microcomputer use by preschoolers." in Research Windows - Novelty in Preschoolers, ed. Betty Collis (Enschede: University of Twente, 1987), 49.

percent of children who had been using computers with adult intervention chose the computer first when asked to rank-order a book, a toy, and the computer. Conversely, nineteen percent of the students with no intervention ranked the computer first.

### **Objectives**

The purpose of this endeavour is to develop an interactive multimedia software to teach number concepts. The objectives of this application are to promote:

- (1) Independence - To help students develop the feeling of accomplishment by being able to work on their own without teacher assistance;
  
- (2) Academic skills - To teach the following number concepts in the most logical and direct way for intellectually disabled students:
  - Numeral recognition (0-9);
  - Rote counting (0-30);
  - Touch counting with one-to-one correspondence;
  - Numeral associations
    - Numeral matching;
    - Numeral to sets of miscellaneous objects;
    - Sets to sets (matching equivalent groups of objects);
  - Numeral sequencing

- Numerals 0 to 20 or more;
- Sequencing a random number in a consecutive sequence;
- Sequencing a random number in a non-consecutive sequence;

(3) Teacher usability - To encourage teachers to want to setup software on their own by providing a user-friendly, easy to use, and logical interface;

(4) An entertaining learning experience.

### **Rationale**

The main reason for undertaking this project is that I felt that something had to be done to address specific problems that special needs students have with number concepts. Rather than waiting for the right application to be developed, I decided to seriously do my best to address a compelling need.

### **A Multimedia Solution**

Today, student independence at the computer is a more feasible goal because of multimedia. MacArthur & Haynes (1987) maintain that "well designed computer assisted instruction (CAI) can be an effective means of maintaining

high levels of task engagement during independent practice."<sup>9</sup>

The missing element in existing alternative tools of teaching is interactive multimedia.

"In its broadest sense, multimedia refers to the delivery of information in intuitive, multisensory ways through the integration of hitherto distinct media - text, graphics, computer animation, motion video, and sound - in a single presentation under the control of the computer."<sup>10</sup>

Probably one of the first questions that come to mind when a new educational software is introduced is "What will this program do that existing programs can't?"

Properly used, interactive multimedia provides a highly motivating learning environment. The proposed multimedia approach is essentially an amalgamation of all the positive aspects of existing mathematics software and a special-education perspective on number concepts.

The first consideration in creating this program was easy access. By using a touch screen as the main input device (while supporting the mouse) the only demand on the student to work with the program is touching. In fact, the program offers minimal keyboard access. From observation, it has been established that the keyboard is often an obstacle to learning for young intellectually disabled children.

In addition, digitized speech in English or French, with

---

<sup>9</sup>C.A. MacArthur, J.A. Haynes, "Computer assisted instruction with learning disabled students: Achievements, engagement, and other factors related to achievement." in Research Windows, ed. Betty Collis (Enschede: University of Twente, 1988), 72.

<sup>10</sup>PC Magazine, July 1990

a male or female voice, is used for teaching, prompting, and feedback. Ideally, students should work independently at the computer, but working in pairs could also be beneficial.

Furthermore, students should be using headphones during computer sessions to cut off any distracting noises. This greatly improves students' attention at task, thus increasing the probability of success of the software being used. This theory found support after being tested internally, following a suggestion by a speech therapist.

There are no specific entry skills required for using this interactive program. It is assumed that the teacher will start the program and set it to the appropriate teaching level for each student.

## Literature Review

In researching a reliable method of teaching number concepts to early childhood, one finds that the labour of numerous scholars has yielded a voluminous wealth of interesting information. Of the various papers reviewed, the following have greatly contributed in the development of a new approach to teaching number concepts.

The more I read through the literature, the more I realized that researchers' findings revolve around very similar theories of concept formation in children. A comparative study (Tousignant, 1990)<sup>11</sup> depicts the similarities in the models by Piaget, Dienes, and Caron and Lepage. Although my purpose is not to produce a synthesis of concept acquisition theories, I would simply like to point out Caron's and Lepage's (1985)<sup>12</sup> main affirmations. They postulate that concept formation is composed of six steps:

- 1) Exploration through the senses;

The manipulation and observation of materials.

---

<sup>11</sup>Marie-Michèle Tousignant, "Paper presented to Jean-Marie Labrie" (University of Sherbrooke, 1990) 2-11.

<sup>12</sup>J. Caron, E. Lepage, Vers un apprentissage authentique de la mathématique. Collection "Outils pour une pédagogie ouverte," in Paper presented to Jean-Marie Labrie, ed. Marie-Michèle Tousignant (University of Sherbrooke, 1990) 2-11.

2) Sensory perception and experience recall;

The child becomes able to describe, identify, compare, and select what he/she has perceived. This is due to the knowledge acquired from manipulation.

3) Representation and mental images;

With the help of material support, the child is able to make associations and comparisons when asked.

4) Intuitive concept or the beginning of abstraction;

The child begins to create constant concepts intuitively but without certainty.

5) Verbal concept and abstraction;

The concept is formed. It is at the stage of abstraction that the child is able to express what he/she has understood in different forms (written, verbal, or symbolic).

6) Generalized concept or generalization;

The child can formulate a final deduction of the given concept and formulate a law which he/she will apply in other situations.

As the reader will notice, the discussed strategies for teaching number skills seem to have been influenced by



Piaget's, Dienes', and Caron's and Lepage's models of concept acquisition.

### **Strategies for teaching number skills**

A teaching model developed by Klassen (1988)<sup>13</sup> is based on the premise that learning in children is more successful when instruction begins at a concrete level and progresses sequentially to higher levels of conceptualization.

#### **Concrete → semi-concrete → symbolic**

At the concrete stage, the child works with real objects and has hands-on experience with the skills and concepts being presented. Subsequently, at the semi-concrete stage, the student is working with pictures, drawings, and diagrams, as well as other representations of concrete objects. To facilitate and heighten the connection between real and represented objects, the child is shown illustrations of objects that are common to his/her environment. Lastly, at the symbolic stage, the child works with symbols without the support of materials or pictorial representations.

Klassen applies this model to teaching number concepts at the kindergarten level. The steps followed in addressing the concept of number recognition are described below:

---

<sup>13</sup>Wendy Klassen, Houghton Mifflin Mathematics Kindergarten -Teacher's Resources Book (Markham: Houghton Mifflin Canada Limited, 1988), T16.

- (1) The student uses one-to-one correspondence to determine whether sets of objects have the same number of objects;
- (2) The student uses one-to-one correspondence to determine which set has more objects;
- (3) The student uses one-to-one correspondence to determine which set has less objects;
- (4) The student compares three sets of objects and determines which set has the most and which one has the least;
- (5) The student uses one-to-one correspondence to create equivalent sets of objects;
- (6) The student identifies sets of 1 and recognizes the relation to numeral 1. Then he/she continues this process through numeral 5;
- (7) The student recognizes numerals 1 to 5.
- (8) The student repeats steps (6) and (7) for sets of 6 through 10 objects.

In this model, before the student actually learns to count objects in a picture, the student learns to: print numerals 1 to 10; match numerals to sets of objects; identify sets which have one more and one less; complete a set for a given number (drawing in missing number of objects); number lines; ordinals first through fifth; and finally, complete dot-to-dot number pictures. It is worth noting that this model does not discuss numeral 0 in relation to sets or as a number to be recognized.

The Klassen model introduces an extensive vocabulary before dealing with number recognition. For example, concepts like same, different, like, larger, largest, smaller, smallest, as well as many prepositions are presented.

Kelleher (1992)<sup>14</sup>, who served as editorial advisor for Klassen (1988)<sup>15</sup> proposes a more logical way of presenting number concepts. She begins by introducing rote counting to 10 and follows with building sets of 0 to 5 objects by sorting a myriad of articles (e.g. buttons, beads, or beans) and counting sets. In this model, sorting on the basis of attributes is believed to be the foundation for sorting on the basis of number. The process of recognizing commonalities and differences in objects helps the student to

---

<sup>14</sup>Heather J. Kelleher, Mathworks, Book A (Toronto: Houghton Mifflin Canada Limited,, 4-133.

<sup>15</sup>Idem 13

develop the required analytical thinking skills of mathematics.

Once the exercises of creating and counting sets are finished, the student moves on to recognizing numerals 0 to 5. Next the student matches numerals to sets of objects 0 to 5. This process is often referred to as number to group matching. Before the student is taught to recognize numerals to 10, he/she will learn to: count by rote to 25 or higher; count back from 10; and count one more and one less. Following numeral recognition to 10, the student learns to order numerals and sets 0 to 5, and then learns to print the numerals.

There is one peculiarity about this model in that building and counting sets to 10 is taught after the numerals to 10 can be recognized, which is the reverse of what is done with numerals 0 to 5.

The next level of representation in this model involves matching numerals and sets to 10, followed by model names for numbers to 5. Here, a new component is added, for which the logic is somewhat difficult to comprehend. One can begin to empathize with students having learning disabilities when written number names are introduced as sightwords (e.g. one, two, etc.) before having completed other important number concepts. Only after having presented the number names are students asked to identify equivalent sets.

Jerome Bruner's (1966) model of teaching as described by

Lyons & Lyons (1991) advocates three modes of representing concepts:

- (1) Enactive (Concrete) representation → involves concrete operations and active participation of children;
- (2) Iconic (Pictorial) representation → involves the use of illustrations, ideograms, pictograms and other graphic tools;
- (3) Symbolic representation → implies resorting to mathematical symbols.

This model suggests a progression in these modes of representation (1-2-3) and it is believed that after children have mastered a representation, they should have the opportunity to return to the other modes.

### **Limitations of existing software**

There exist many programs that attempt to teach number concepts: *Talking teacher; Animated numbers; Berenstain Bears Math; Counting Critters; Learning about Numbers; Animal Math; and Math Rabbit* to name a few. They each have their distinct way of presenting information, asking questions, and giving feedback.

If the variety of approaches contained in these programs would be put together, perhaps it would result in a program that can really teach number concepts. In general, few of the programs actually teach number concepts. Instead, they reinforce what has been taught in class, and often require the assistance of the teacher to work with.

After more than two years of careful observation at the Summit School computer lab, numerous deficiencies in existing educational software in addressing the special needs of this population have been identified.

The major shortcoming of many existing software is that access is by keyboard only. It should not be required of anyone to be able to locate the number keys on the keyboard to learn how to count and identify numbers. To impose the use of the keyboard onto a student who has seldom or never used a computer and expect he or she to perform on new software, is like introducing two new variables into an equation and expecting to be able to distinguish the effects of one of them on the whole. If the results are poor, it is more difficult to determine the contributing factor: the location of the keys on the keyboard, understanding of the concept being taught, or both. Once this obstacle is removed, the child can focus on one task only, learning numbers concepts.

In addition to the 84-plus keys on most keyboards, the functioning of the teaching part of many programs, is too

overwhelming for the student. For example, the program may require that the teacher instruct the student to: move the box (i.e. cursor) to the same picture using the arrow keys and press enter to select or press the key on the keyboard that looks the same as the one you see on the screen.

Another weakness in several educational programs is that questions and feedback are offered as text to a child that can't read. The obvious solution is to use digitized voice.

Some programs also require a high level of eye-hand coordination for precise mouse action, thus presenting yet another obstacle.

As for mathematics ability considerations, one will find that no software takes into account problems of double counting when doing one-to-one correspondence. Many often have the objects to be counted too small and too close to one another, thus creating a greater challenge for students with difficulties in visual tracking and fine motor movement of the hand.

Other important factors which contribute to the success of a particular program are music, sound effects, animations, and corrective feedback. Appropriately used, these factors help create a motivating learning environment, but they are not present in a lot of software.

## **Design**

### **Teaching Strategy**

The teaching strategy used in this software is a variation of Bruner's (1966)<sup>16</sup> model. One starts with iconic representation where numbers are introduced as distinct pictures (by rote), in the same way, for example, that one is shown any object, such as a cup, and is told that it is a cup as it is presented. In essence, the student is learning a pictorial representation first. This is equivalent to the semi-concrete stage of the Klassen (1988)<sup>17</sup> model. Once the students have complete numeral recognition, by being able to associate verbal numeral names to numerals, they can move on to enactive representation. At this stage, concrete objects are presented in relation to the iconic representations. Here, the concrete objects refer to common objects presented in two-dimension on the computer screen (e.g. pencil, house, etc.). Subsequently, interactive participation of the learners will, it is hoped, raise the understanding of the object-number association. Students are progressively taught to associate groups of objects to numeral pictorials. Numbers are then faded out slowly as groups of objects begin to have meaning in the student's mind by making reference to

---

<sup>16</sup>Jerome Bruner, "Toward a Theory of Instruction," in Challenging Mathematics I (Laval: Mondia Editeurs, 1991).

<sup>17</sup>Wendy Klassen, Houghton Mifflin Mathematics Kindergarten -Teacher's Resources Book (Markham: Houghton Mifflin Canada Limited, 1988), T16.



a picture of a numeral. Following this, students can move on to one-to-one correspondence or touch counting.

Through out the software, colour was used to motivate the learner and the teacher, with vivid menus, numbers and the animations. Hativa & Teper (1988)<sup>18</sup> found that colour had a positive effect on motivation and possibly learning, when used for cuing. It was observed that students had a more positive attitude towards learning with colour than without. Furthermore, it was suggested that low ability students benefited most from colour software.

---

<sup>18</sup>N. Hativa, A. Teper, "Differential effectiveness of three color treatments in learning geometric concepts via computer guided teaching," in Research Windows - Color as Significant Variable, ed Betty Collis (Enschede: University of Twente, 1989), 86.

### Putting the strategy on the screen

- (1) The program begins with counting by rote, presenting numerals one at a time on the screen. Each numeral is brought from different sides of the screen to the center. Once the numeral has stopped, the numeral name is said (coming out through the connected speakers). This allows for the association of the numeral pictorial to the numeral name. Between each numeral, an animation, selected at random from a defined set, is displayed on the screen (See Fig.1).

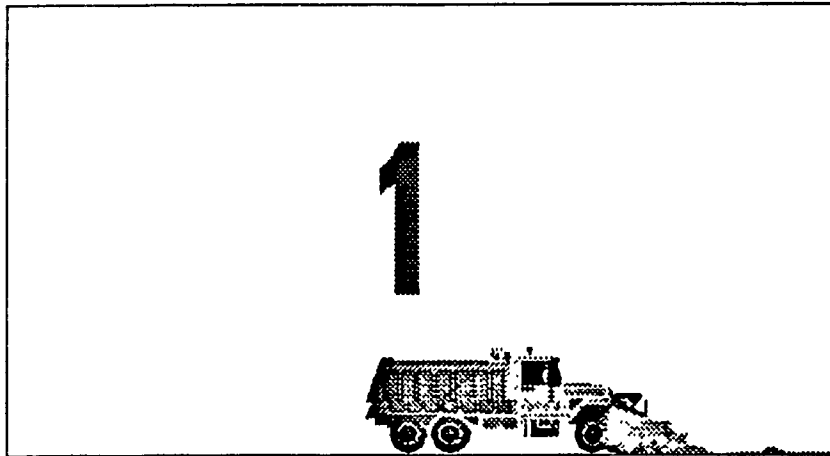

Fig. 1. Rote counting to numeral recognition

- (2) A second method of counting by rote presents numerals one at a time at the bottom of the screen, for one second. The numerals are then moved in order to the top of the screen. Once a numeral reaches its

sequential position, the numeral name is said. This is an informal introduction to the concept of sequencing in numerals. By keeping all numerals on the screen, the student learns to anticipate what will come next (See Fig. 2).

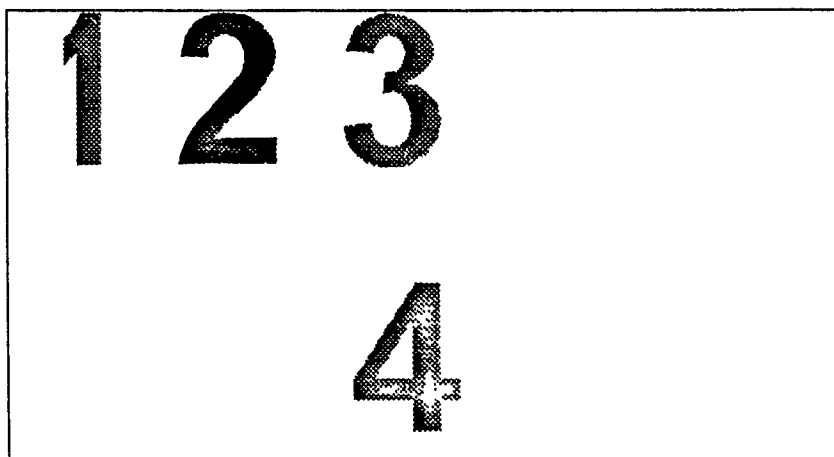

Fig. 2. Sequential positioning to numeral recognition

- (3) Once counting by rote has been established and that numerals can be identified as pictorial, the numerals are given meaning by associating them to groups of identical objects, one object at a time. One object is displayed, numeral one is shown, and then the numeral name is said. Next, the numeral is erased, a second object is presented, numeral two is shown, and the numeral name is said. This goes on until the limit numeral of the set level is reached, at which

point the sequence is repeated as requested. As one would expect, when numeral zero is presented, no objects are displayed, but the numeral name is said. This is an introduction to both "touch" counting and association of numerals to sets of identical objects (See Fig.3).

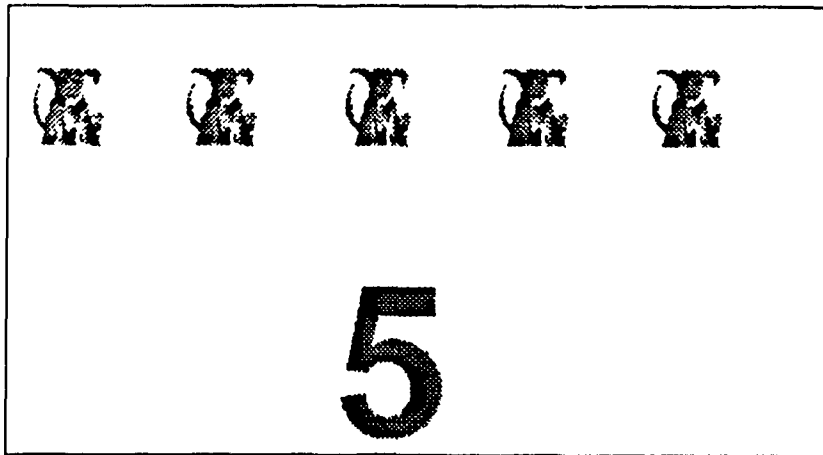

Fig. 3. Numeral association to groups of objects.

- (4) To further reinforce the concept of sets, counting by correspondence is used next. The screen is divided in two equal size halves (left and right) with a group of objects on the right side. As an object is touched (in any order), it is moved to the other side of the screen. The numeral corresponding to the number of objects on the left side is displayed, and the numeral name is said simultaneously. This method

of counting teaches the concept that one more object gives you the next numeral and a larger set of objects. This technique of counting also eliminates the possibility of double counting of objects in forming sets, especially for students with difficulties in visual tracking and fine motor movement (See Fig. 4).

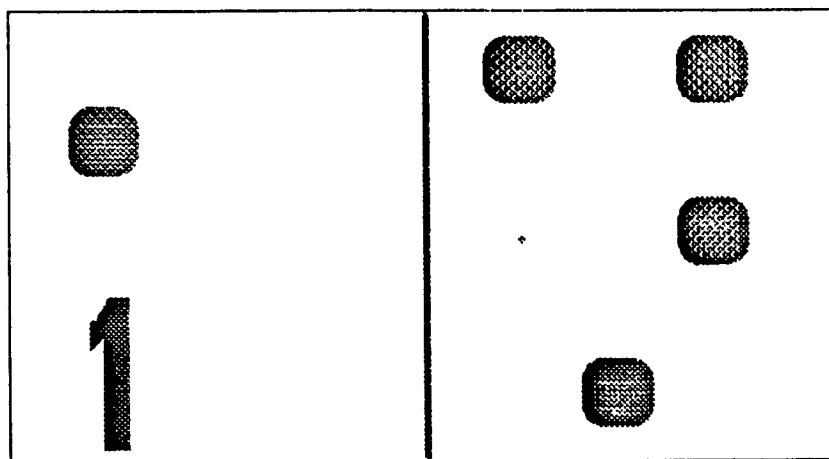

Fig. 4. Forming groups of objects with a split screen

- (5) The last level of counting is similar to the previous method in that objects can only be counted once. The difference here is that the objects shown are static. Evenly spaced objects are placed on a horizontal line. As they are touched (in any order) they are filled by a colour, indicating that it has been counted. The numeral name of the total number of

objects filled is then said after the numeral pictorial is displayed below the counted objects (See Fig. 5).

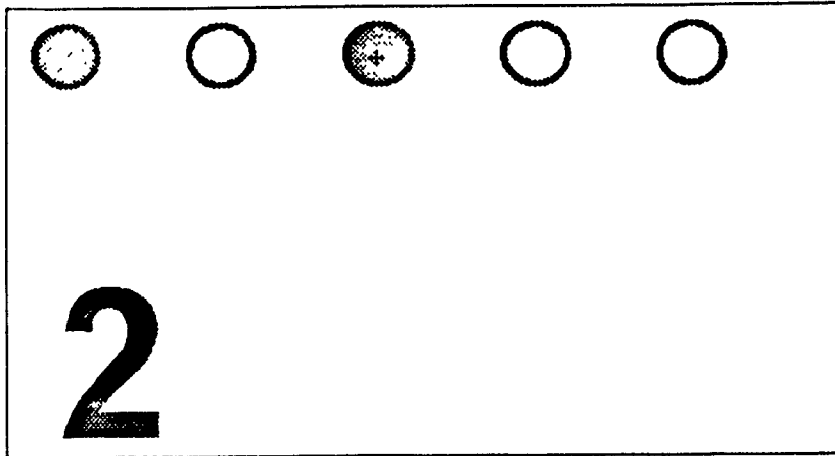

Fig. 5. Touch counting at random

#### **Testing the concepts on the computer**

Careful reflection has gone into the design of the testing methods.

The number recognition testing works as follows. The screen is divided into equal quarters, separated by one vertical and one horizontal line at the center of the screen. In each quarter is placed a numeral (See Fig. 6).

3	0
1	4

Fig. 6. Starting screen - numeral recognition test

The numeral being tested follows a defined series, which is different for each level of testing (i.e. recognition 1 to 5, 0 to 5, 1 to 9, 0 to 9 etc.). Once the numerals are in place, in their respective quarters, the student is asked to touch a particular number from the series. If the numeral is identified correctly, a positive sounding sequence of computer noises is given and a clown face is shown over the numeral. If an incorrect identification is made, a short two-tone noise is given, and a colour-changing box is placed around the correct number as a reinforcer (See Figs. 7 & 8).

	0
1	4

Fig. 7. Recognition testing - positive reinforcement

<b>0</b>	3
5	1

Fig. 8. Recognition testing - corrective feedback



The idea is not to dwell on the fact that the student has made a mistake. Many students are very conscious of their errors and may lose interest in the program if too much stress is put on wrong answers. The proposed approach uses a positive reinforcement for correct answers and corrective feedback for incorrect answers. The corrective feedback is a positive way of addressing wrong answers in that the student is given the correct answer or the correct count as if the computer was working with the student and moves on. The objective of testing the various concepts is to determine problem areas of the students.

The position of the numeral being tested is randomly assigned to a quarter, hence making it virtually impossible to remember the test numeral position from one testing session to the next. Each numeral is asked three times during the test, thus giving only a 1.6% probability of correctly identifying a numeral on all three showings, when the student is guessing. Decreasing this probability could only be done by increasing the number of numerals shown on the screen. Unfortunately, this would also mean that the test numerals be smaller, which was not desired in this program. In the end, once the test is complete, a summary sheet of the student's performance at any particular level is shown on the screen.

It is worth noting that a student management system was not developed because it was found that teachers in general

rarely make reference to student performance records on computer software from one session to another.

The testing method for touch counting uses the same numeral randomization for the positioning of the test number as the number recognition testing method. In this method, however, the tested number of objects to count are placed at the top of the screen, while the numerals are laid out horizontally at the bottom (See Fig. 9).

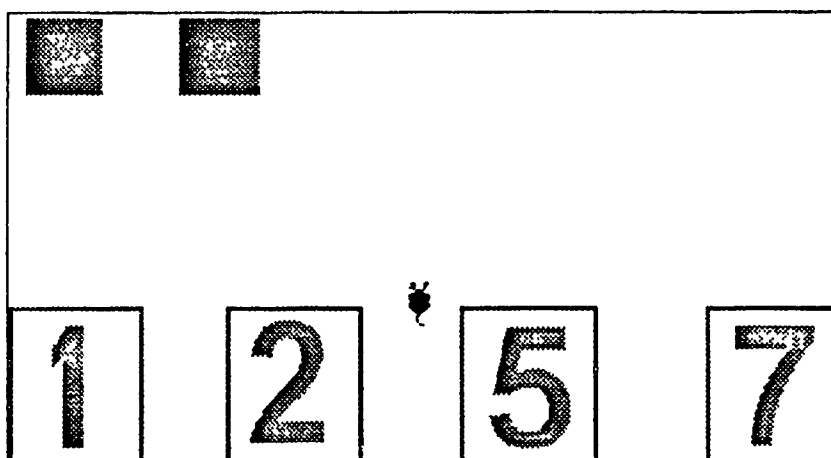

Fig. 9. Starting screen - counting test

If the numeral corresponding to the number of objects shown is identified correctly, a positive sounding sequence of computer noises is given and a clown face is shown over the numeral (See Fig. 10). If an incorrect identification is made, a short two-tone noise is given, followed by corrective feedback which tells the student "Let's count together," and proceeds to counting the displayed objects out loud, one by

one, making a box around each object and placing the corresponding counter numeral next to the object. Once the corrective counting is finished, the corresponding numeral at the bottom of the screen is coloured in for reinforcement (See Fig. 11).

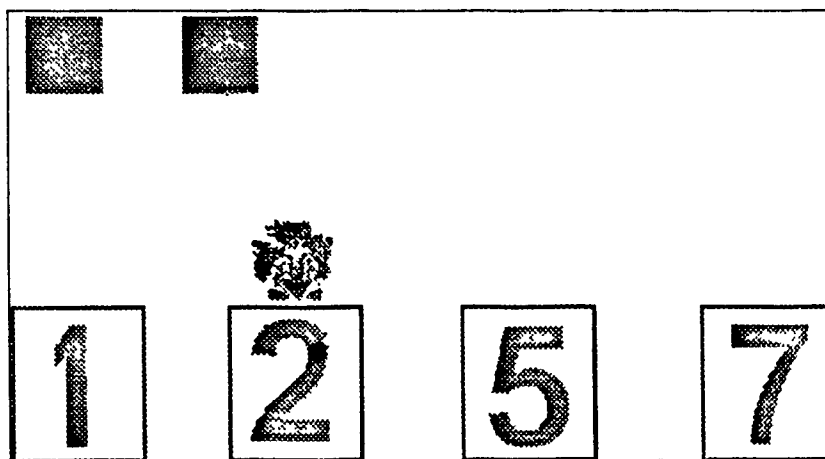

Fig. 10. Positive reinforcement - counting test

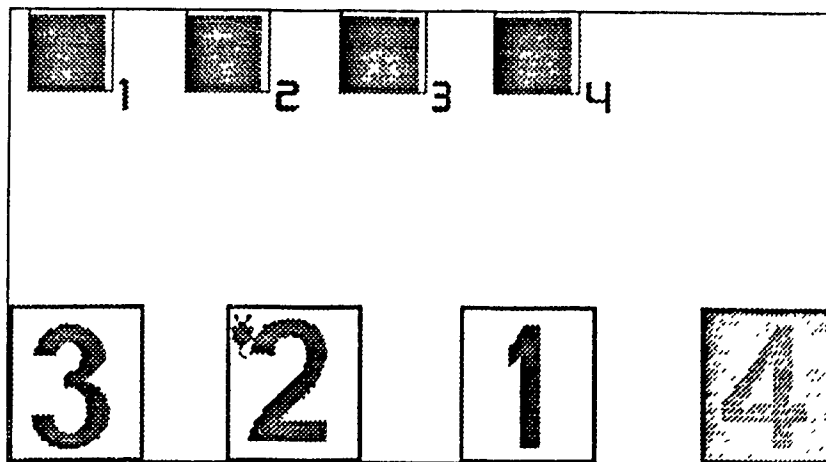

Fig. 11. Corrective feedback - counting test

This approach to feedback was somewhat influenced by the findings of Beaulieu (1985)<sup>19</sup>, who observed that students paid relatively little attention to feedback of correct answers while spending twice as much time studying the feedback for incorrect answers. It was also found that varying the delay of feedback made no difference in student learning.

### **Special considerations in design**

A major concern in the instructional design of the software was that the use of graphics and animation be age appropriate. Many older students (aged 8-12) also have great difficulty with number concepts, and many are aware of their disability. Therefore, the types of graphics and animations used are important to consider, and must not be too childish. One does not want to make older students feel like they are being treated as young kids. Yet one must be careful that the graphics and animations are not aimed too high for the younger audience. The challenge was making them interesting for both populations.

---

<sup>19</sup>J.E. Beaulieu, "A study of the effects of selected feedback delay intervals upon retention of science material in a computer assisted instructional task with junior high school students" (Ph.D. diss., University of Oregon) in Research Windows - Assessing the Value of Immediate Feedback for Correct Answers, ed. Betty Collis (Enschede: University of Twente, 1986), 27.

## **Contacts with experts**

In an effort to further support the viability of my design's approach, consultations with a variety of para-medical and special education professionals were carried out over an eighteen month period.

Psychologists were consulted for assistance in establishing the main psychological disorders as well as behavioral issues. More precisely, the types of behaviours to expect and how to deal with the students on any particular incident.

Speech therapists were consulted for insight in general communication with students with learning disabilities. Specifically, they gave advice on image presentation with respect to size and use of colour, and on the use of digitized speech with headphones for normal and hearing impaired children.

Occupational therapists were consulted for ergonomic insights when using the computer. The consultations provided two main recommendations:

- (1) To make sure that the inclination of the monitor and height of the chair placed student eye-level at the center of the screen during teaching, so that the neck remains straight, putting little demand on neck muscles; and

- (2) The ideal position of the student when using the touch screen input device is having eyes at least eighteen inches from the screen while providing comfortable elbow rest. For the mouse, it is important that the student be able to rest his/her forearm on the desk during sessions, thus relieving the shoulder muscles.

Special education teachers were of the greatest help through out this project. These "consultants," with years of experience in working with intellectually disabled children, provided a wealth of practical information.

To assist me in developing a teaching strategy, and also to see how real world experience compared with theory, I asked teachers the following questions: how they presented numbers for the first time; how they introduced touch counting; and how they tested number recognition and touch counting. Furthermore, they were asked to state what they believed to be general areas of difficulty with their students and number concepts.

Basically, when the teacher's resource book guidelines don't seem to work, the teachers must use their ingenuity until there is no hope of success. The major areas of difficulty reported were: fine motor and visual tracking problems which make touch counting more difficult, causing the child to double count, and attention at task during

teaching in general.

With respect to educational software, teachers were asked what they generally liked or disliked about various mathematics programs they have used with their students.

The overall teaching approach of the multimedia software developed was greatly influenced by the teachers' input.

### **Designing the user interface**

The user interface in a software refers to how a user interacts with any particular program. It is as important as the software's content, for users who have difficulty working with the shell of a program, will tend to stop using it. The best user interface designs start by considering people and not things.<sup>20</sup> For the user to feel comfortable using a program one must provide an environment which is clear, coherent, logical, and intuitive, specifically designed for its intended users.

Using these guidelines, in addition to my ten years of experience in using computers, and having reviewed hundreds of educational programs, I have tried to design a succinct and effective user interface. My goal in designing this interface was for the teacher to be able to navigate freely in the application, without worrying what to do next, and how to exit. My ideal was to provide a "No documentation

---

<sup>20</sup>Bob Jacobson, "The Ultimate User Interface," Byte Magazine, April 1992, 1/6.

required" software.

### **User interface issues regarding teachers**

Teachers who use computers in classrooms or in a computer lab often do so because they have some interest in computers and not because they are obliged to do so. Most of the teachers have never had formal training in the use of computers, or the integration of software with school curricula. Mokros & Russell (1986) found that out of fifty American school districts, not one teacher reported receiving training on how to integrate educational software to curricula.<sup>21</sup>

When designing a user interface intended for teachers with little or no computer experience, there are a few important items to consider:

- (1) So many programs exist on the market, each having their own way of accessing teacher options for setting teaching levels, that having one more to remember is asking too much of the teacher. Unless teachers always use the same set of programs, they tend to forget how to change levels.

---

<sup>21</sup>J.R. Mokros, S.J. Russell, "Learner-centered software: A survey of microcomputer use with special needs students." in Research Windows, ed. Betty Collis (Enschede: University of Twente, 1988), 72.



(2) When a student is playing with a software and the teacher realizes that it is not set at the right level, many software will require that the teacher: 1) Go back to the main menu; 2) Enter teacher options; 3) Change the setting to the appropriate level; 4) Go back to the main menu; and 5) Return to the program activity. This tedious procedure is often too much to ask when students of the target population are not very patient to begin with.

(3) Most programs come with a user's guide. However, few people like having to resort to this manual to learn how to operate a particular program (and rarely do).

Rather than having to remember the proper commands to arrive at the teacher options for every program, and following all the steps to make changes, the interface was developed in such a way that the teacher options and program levels follow naturally when starting the software. Furthermore, the teacher is able to quickly change the teaching method and level once the student activity has begun, or proceed to testing a particular concept (See Figs. 12a & 12b).

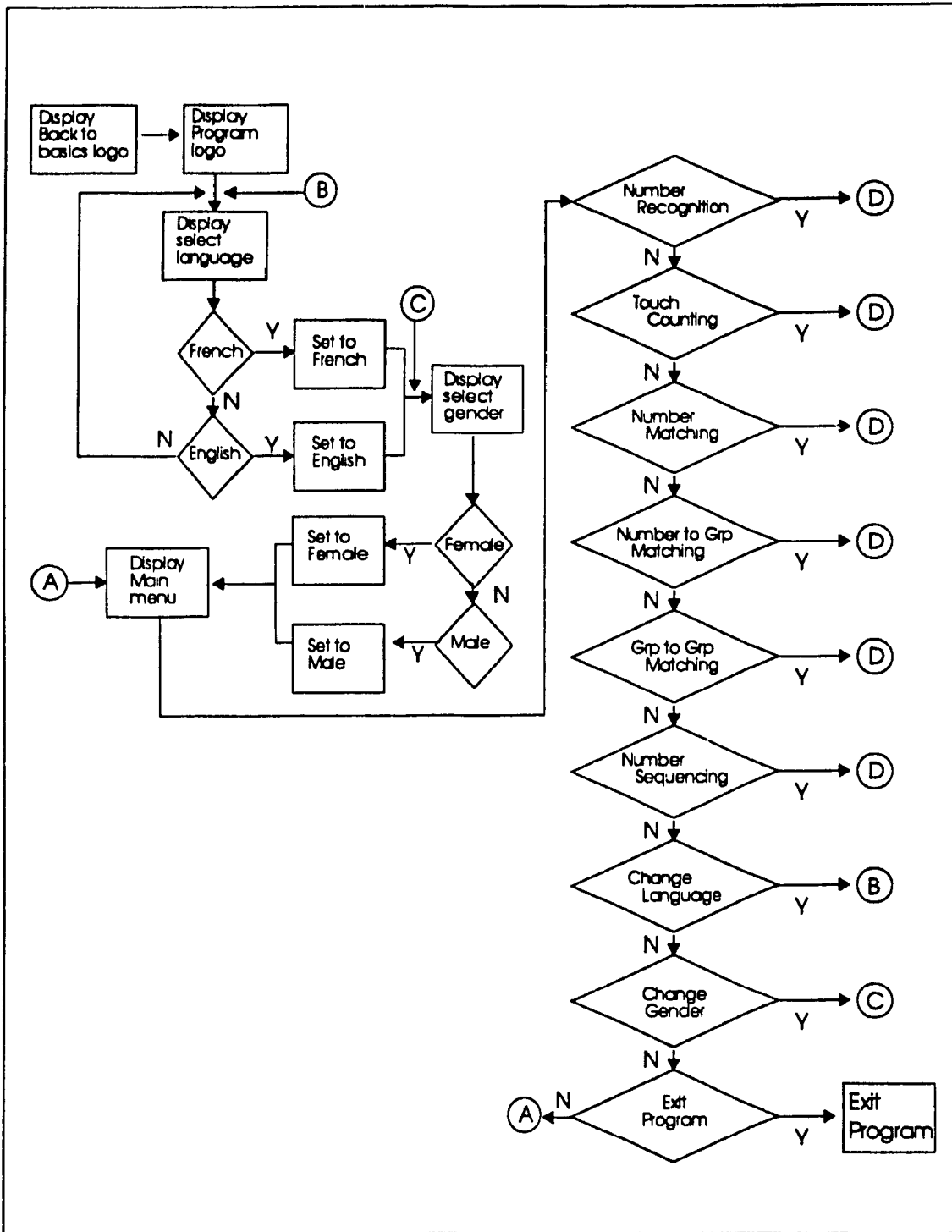

Fig. 12a. Interface flowchart - part A.

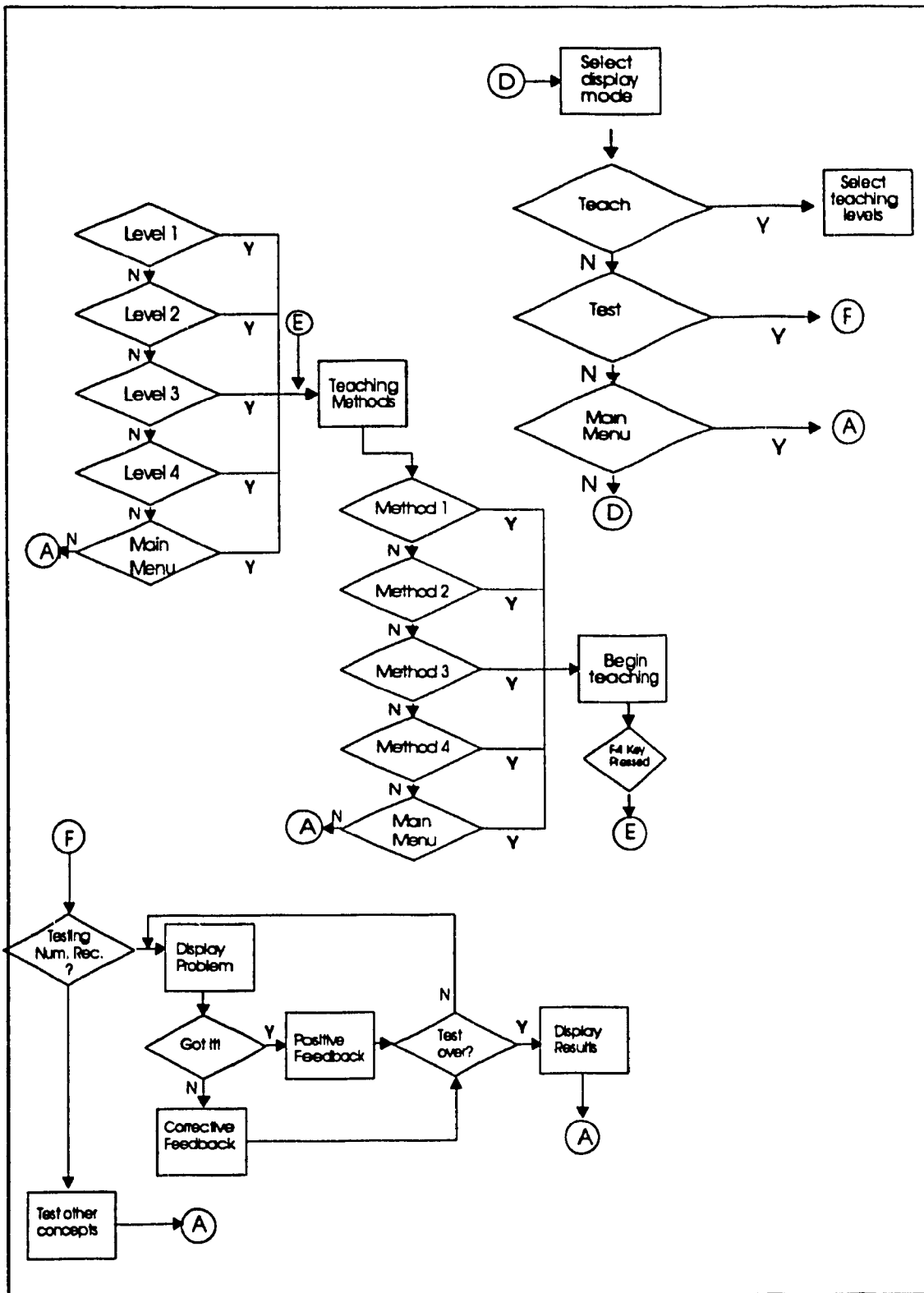

Fig. 12b. Interface flowchart - part B

## **Researching authoring systems**

Ideally, a software should be released for all major computer platforms (i.e. Macintosh, IBM-DOS, IBM-Windows, OS/2, etc.). Realistically, however, the economic implications of such a philosophy are phenomenal. Only large software publishers can afford such luxury. The choice of platform for an educational software of this proportion is dependent on several technical considerations and a few marketing strategies.

For people with relatively limited resources and a development project in mind, the most important factor determining it's feasibility is the choice of development tool or authoring software. When considering which authoring tool would work best for a particular project, one must know exactly what they want to achieve.<sup>22</sup>

An imperative consideration early in the selection of the tool, is the cost of licensing and distribution. Ideally, one should be able to compile the finished product into a non-editable application, free of "run-time" licensing fees.

Based on a compilation of authoring software reviews (on various platforms) and the design outline of the desired final product, several technical requirements were set for the authoring tool to be used for the development this multimedia program: full touch screen and mouse

---

<sup>22</sup>Jim Canning, "Multimedia Authoring Tools," Infoworld Magazine, 9 March 1992, 76-77.

compatibility; ability to playback sampled sound in .SND, .VOC, and .WAV formats; sound board compatibility (Soundblaster, Adlib, Covox, Realsound); ability to playback MIDI or .CMF music files and CD-audio; ability to create multiple animations; ability to playback Autodesk .FLI and .FLC animations; ability to support high resolution graphics in 256 colours; ability to import and manipulate bit-mapped files in two or more file formats (ie: PCX, TIF, GIF, or TGA); basic flow-control operations such as looping and conditional branching along with calculation and data manipulation capabilities; debugging facilities; string manipulation tools; timing controls; dynamic file input/output; capability to set jumps from one static element to another; ability to set place marker to allow a return to the start point; and programmable teacher management options for maintenance of student performance and program level.

### **Computer platform selection**

From a marketing perspective, we must look at the most widely used platforms. The target market for this product is, for the most part, elementary institutions. Many educational institutions already have computer labs that are equipped with the following types of computers: Apple IIgs, Apple II, Macintosh and IBM compatibles. Some schools may have Macintosh computers with colour screens, but there are only a few. The Apple IIgs market is large because at the

time when schools began allocating funds for computers, the Apple II computers were considered as the "Educational Computer." When the Apple II and IIe were replaced by the more expensive Apple IIgs many schools "upgraded" their systems. Today, with budget cuts being an every day reality for school boards, upgrades to costly, newer, more powerful colour systems are carefully evaluated.

Technically speaking, the use of Apple IIgs computer for a project of this size is inconceivable. For systems not equipped with a hard drive, which is most often the case, it would entail continuous disk swapping. Moreover, the Apple IIgs has been discontinued by Apple Computers.

Although the Amiga and Macintosh platforms are appealing, the number of users at the elementary school level is not high enough to warrant selecting either as the first platform of development.

With the prices of IBM computers, clones, compatibles, and accompanying hardware decreasing steadily, the IBM market appears to be a more promising avenue.

Out of the many authoring software packages reviewed (on both the Macintosh and IBM operating systems), only IBM compatible software offered the desired tools.

The programs considered for the development of the product included: IconAuthor 4.0 (Aim Tech Corp. \$4995 US); Quest Multimedia (Allen Communications \$1195 US); HSC Interactive (HSC Software \$395); Grasp 4.0 (Paul Mace Software \$395 US);

Multimedia Grasp 1.0 (Paul Mace Software \$1195 US); and AskMe 2000 (ICS \$395 US). For each of these authoring packages, a demonstration copy was obtained through the companies for a detailed evaluation of the program specifications.

The software chosen for the development of the multimedia application was Grasp 4.0, which was later upgraded to Grasp 5.0 and Multimedia Grasp 1.0, all from Paul Mace Software.

The minimum computer system requirements to run this multimedia application are:

- 80386 sx 40Mhz CPU
- 2 Megabytes of RAM (4 MB recommended)
- Soundblaster or compatible sound board
- 10 MB of Hard disk space
- VGA colour monitor
- Speakers or headphones
- Touch screen or mouse

## **Development**

The title chosen for the software developed is "Multimedia Numbers."

Due to the scale of this endeavour, the software was not completed in its entirety. The following was fully developed for the thesis, namely:

- Teacher/User interface (English and French);
- Teaching numeral recognition (2 methods);
- Teaching touch counting (5 methods);
- Testing of numeral recognition;
- Testing of touch counting;
- Computer animations; and
- English, French, male, and female digitized speech.

## **Production tools**

In addition to the authoring software, which provides the structure and flow of the program, a series of important production tools were needed. For image creation and editing the following programs were used: CorelDRAW 4.0 (Corel), PHOTOPAINT 4.0 (Corel), Neopaint (OCHS), TGLplus (TerraVision), and Pictor (Paul Mace). For audio recording, editing, and file type conversion the following programs were used: MCS Stereo (Aniotion Development Corp.), SoundBlaster Wave studio (Creative Labs), and SoundBlaster VEDIT2 (Creative Labs). For prototype development awaiting the



development tool, CorelCHART (Corel) was used.

### **Methodology**

The methodology used for the development of the software was as logical and time efficient as I could make it. Before initiating the research of the authoring software to be used, several ideas were first put to paper. I began by sketching out the user interface to determine the most effective sequence to arrive at the student activity. Then, I proceeded to create mock-up screens of the interface and, using the CorelCHART presentation package, I was able to test the flow of interface. This form of rapid prototyping greatly helped in the final development of the interface. In fact, by working with the interface as a "skeleton," I was able to eliminate a few screens, resulting in a clearer and easier to use interface. The general idea was to provide the user with a flexible environment, where available options are intelligible. At any point in the software, the user is able to return to the previous screen or to the main options menu, as well as change the gender of the voice being used and the language of the program (See Fig. 13).

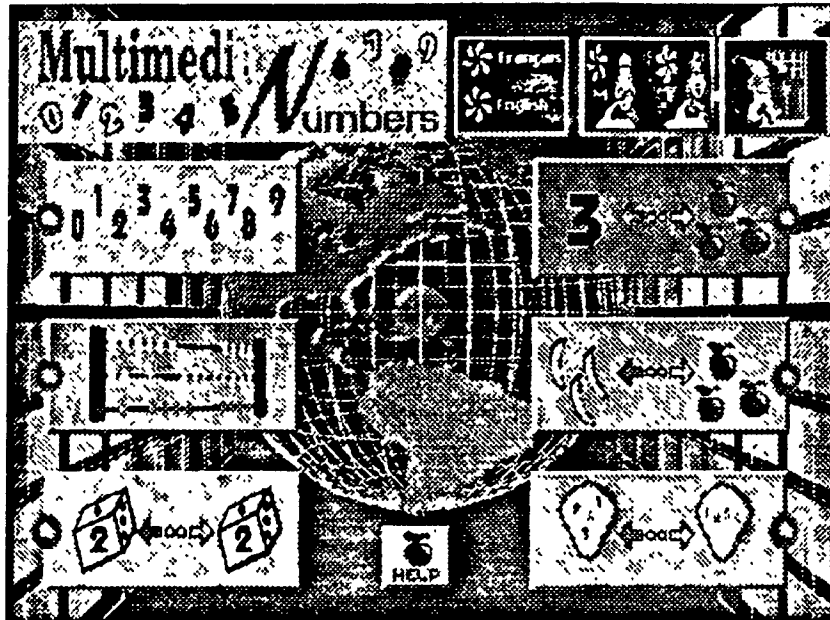

Fig. 13. Interface Main Menu

All animation sequences used for concept presentation in each of the teaching methods, were sketched out on paper using a variation of the common storyboard format used in design. Once development began, however, I realized that the sequences on paper were very difficult to put on screen using Multimedia GRASP. As a result, redesign and compromise were in order, as development was suspended.

As development progressed, more discoveries were made in programming with GRASP, allowing for program code to be reduced considerably. As the software began to take shape, formative testing of the interface and teaching methods during development provided the opportunity to correct the various bugs in the program before the evaluation of the software took place.

## **Problems encountered during development**

An enormous challenge in working with a new development tool is learning to work around its limitations and peculiarities. Using GRASP several problems were encountered.

The first problem, which is often the worst type, was memory access. In order to leave as much free memory as possible for the next routine, every memory variable and loaded image not in use had to be released from memory. Even when all images and variables are released an "Out of near memory" error appears. Paul Mace Software is aware of this problem and has been issuing program patches, but the error still occurs sporadically. It was also found that GRASP is not compatible with some expanded memory managers, namely Quarterdeck's QEMM, causing erratic behaviours in the computer. Another memory problem was with digitized sound (SND) playback and CMF music file playback. For some unknown reason a digitized voice file cannot be played with music in the background unless the music was recorded as part of the sound file, even though the drivers for both SND and CMF files can be loaded simultaneously in memory at a different address.

The second problem was getting rid of screen flickering during animations. This was solved using two-page animation, where the next image to be displayed in an animation is drawn on a backpage as another image is shown on the screen

(frontpage). The challenge here was determining when to reverse the pages when animations changed direction or came to an end.

Another problem faced, which made the difference between a clean interface and a sluggish one, was image transition. Each image generated on the computer has its own palette of colours. Depending on the graphics mode and screen resolution selected, the palette of colours for a given image can vary almost indefinitely. As a result, when an image displayed on a computer screen is replaced by another, a new palette must be generated before it can be displayed. When working with 256-colour VGA images (640 x 480 pixels) in GRASP, the transition from one palette to the next can be seen on the screen. During the transition it appears as though the first image takes on the palette of the next image before the second image is displayed. This does not provide for smooth transition from one screen to the next. In trying to solve this problem I realized that the only way to avoid these sloppy transitions was for the next image to have the same palette of colours. Since each screen was designed separately, using a variety of palettes, I had to find a way to change all graphics to a common palette, without recreating the graphics. Fortunately, I discovered that Neopaint (OCHS Software) offered a feature which permitted one to save an image with the palette of another.

As the development of the program progressed I realized

that it was beginning to take a lot of disk space. In an attempt to maintain program size at a minimum, I made an interesting discovery. By converting graphic images from the PCX file format to the GIF format, the files took, on average, fifty percent less disk space.

What occupies the most disk space in the program are the sampled voices or digitized speech. The voices used in the software were recorded at a sampling rate of 22 Khz. The only way to reduce the size of these files would have been to record them at a lower sampling rate, but this would have resulted in an undesirable sound quality.

Once the animations were added on to the program, it became clear that the CD-ROM would be a better medium for Multimedia Numbers. When completed this program could take in excess of twenty-five megabytes of disk space. Unfortunately, though, "pressing" small quantities of CD-ROMS is expensive.

## **Evaluation**

### **Student evaluation**

The formative evaluation of the product was conducted by myself, over a period of five weeks. A total of twelve students from the target population and five teachers, all from Summit School, participated in the evaluation. Coincidentally, the group of students consisted of six males

and six females. Out of the twelve students eight students were diagnosed as developmentally delayed, two as globally delayed, one as trisomic (Down's), and one with Williams' syndrome. It is important to note that two students were non-verbal and three others had communication disorders. The age of the participants ranged from 5 to 10 years (3 of five, 3 of six, 3 of seven, 1 of eight, and 2 of ten) giving a mean age of 6.83 years.

The first part of the formative evaluation was to determine the initial level of the candidates with respect to their comprehension of number concepts. Each student was pretested on the following concepts: numeral recognition; rote counting; and counting.

(1) Numeral recognition (0 - 9)

This test was done using computer generated numerals printed with a laser printer, and cut into individual cards. Each numeral was represented in three different styles (black on white background, white on black background, and numeral outline on white background) and in two different fonts. The variety of numeral representation was used to verify whether students could better identify one set of numerals over another, and whether those students who could identify all numerals in one style, could generalize their aptitude. The numerals used for this pretest can be seen in appendix C.

(2) Rote counting 1 - 30

To verify each student's ability to rote count, students were asked to count out loud, starting with one, and stop when he or she wanted to. The students were asked to do this activity twice. During the rote counting, data was kept on numbers skipped and the last number counted. This part of the pretest gave an idea of the students' current level of number awareness.

(3) Touch counting (0 - 9)

Here, I was interested in finding a possible source for the problem of touch counting that is common in this population. Each student was asked to count ten groups of objects (0 through 9), represented in five different ways:

- (1) Large black dots printed very closely on paper
- (2) Large black dots printed at one inch intervals on paper
- (3) Real objects - wooden sticks
- (4) Existing computer program - Berenstain Bears Math
- (5) Existing computer program - Arithmetic Critter

**Procedure**

As one would expect, this extensive pretest could not be administered in one sitting. When students feel too overwhelmed with numerous questions they lose all motivation. One must keep in mind that students from the target

population already have a shorter attention span. If the test is too long, students lose concentration and purposely make mistakes to get the ordeal over with as soon as possible, resulting in a poor reading of their real abilities. For this reason, the pretest was done in two sittings of fifteen minutes, integrated with play time on a computer game selected by the student. The data collection sheet used for the pretest is in appendix A.

Following the pretest each student had three sessions of approximately 15 minutes with the program, over a three week period. The students were set to work independently on the computer, using the various teaching methods of the level chosen based on the results of the pretest. During every session, notes on the students' behaviours, attention at task, verbal responses, and general interest in the program were taken. The data collection sheet used for these notes is in appendix D.

After their sessions with Multimedia Numbers, each student was retested on the skills they worked with in the program. This test was to determine whether having worked with the software had increased their understanding of a particular concept. The posttest followed the identical procedure as the pretest. The data collection sheet used for the posttest is in appendix B.

Each class at Summit School follows a schedule of team teaching where students from various classes are grouped by



skill level. In order to minimize interference of the children's programming, and the risk of making them fall behind with respect to their teaching group, students could only participate in three try-outs of the program. Considering that each of the twelve participants had to be removed four times from their teaching groups for the pretest and posttest, it was difficult to coordinate the evaluation over a longer period without affecting the students' programming.

#### **Results of the student evaluation**

From the pretest it was found that ten of the twelve students were able to rote count past ten (the exceptions being the non-verbal students). However, only 6 students could recognize numerals 0 through 5, and only four of these could recognize numerals 0 through 9. The other students could recognize either one numeral or none at all. Some inconsistencies were found though in the recognition of numerals 6 and 9, where numeral 9 was often identified as numeral 6 or 7, and numeral 6 as 9. As for touch counting, the results were very different from what had been expected. I had hoped to find that students who could count had more difficulty with close objects than with distant objects. Basically, it was found that only six students could consistently count a group of three objects. It is worth noting that only five students could identify a group of

objects as zero when no objects were given to count. A summary of the pretest results is given in tables 1 and 2.

While students were playing with Multimedia Numbers, some very interesting observations were made. When using the first teaching method of numeral recognition, the students were very focused on the animation of the numbers to the center of the screen, and especially on the "Fun" animations following the verbal announcement of the numeral names. The animations in the program use real sounds. One student seemed scared of an animation when an airplane flew across the screen, and he put his hands over his ears until the plane was gone.

From the first trial of the program, some students would anticipate the following numeral to be said and shown, by saying what they thought was next out loud. Even if the student was wrong in the anticipation of the number, he or she would often repeat the correct numeral name after the computer. The majority of the students (8 out of 12) were able to play independently with the program for the entire fifteen minute session. With the students working with the touch counting modules, method four, which has a split screen and the objects to one side, seemed to work best. In general, students tended to count out loud with the program as the objects were moved to the other side of the screen. One of the students, who is really shy, began to say the numbers out loud. The students were touching (with the mouse) the objects at random and appeared to have a feeling of achievement as

they counted with the computer and watched the objects appear on the other side.

A major drawback during the sessions was that students had to use the mouse because a touch screen was not available. Fortunately, the students who participated in the counting had the required eye-hand coordination to work with the mouse. When touch counting was tested using Multimedia Numbers, having to use the mouse was a problem for some students, because they would not release the mouse to touch and count the objects on the screen with their finger. Instead, many guessed the answer without counting, and would wait to count along with the computer during the corrective feedback of the problem. Some students seemed to prefer using the testing method over the teaching ones for touch counting, because of the positive and corrective feedback it offers.

One student, when asked to choose the gender of voice and language, opted for the French female voice, and really enjoyed his sessions. Even though the student was English, he knew the numbers in French and liked the practice. I was very pleased with what I observed during the sessions. No behaviour problems were encountered.

The results from the posttest (see tables 1 and 2) showed no significant change in the students' abilities. As shown in tables 3 and 4, the analysis of variance of the pretest and posttest resulted in the acceptance of the null hypothesis  $H_0: u_1 = u_2$ , at a significance level of 1% for both numeral

recognition and counting. Hence, this indicates that no significant change in student performance can be attributed to exposure to the program. This is not surprising, due to the limited number of sessions with the software. Judging from the students' general enthusiastic behaviour while working with the program, it is strongly believed that more consistent exposure, on a longer term basis, would be beneficial to the students. One must also keep in mind that the students in the target population are intellectually disabled and usually require a great deal more drill and practice than regular stream students to acquire a concept.

Table 1  
 Numeral Recognition Pretest and Posttest Data

Numeral	Student																								Total	
	Numeral Recognition																								Pre	Post
	1	2	3	4	5	6	7	8	9	10	11	12	1	2	3	4	5	6	7	8	9	10	11	12		
0	X	X	X	X	X	X	X	X	X	X		X	X	X	X									8	8	
1	X	X	X	X	X	X	X	X	X	X		X	X	X	X									8	8	
2	X	X	X	X				X	X	X	X		X	X	X	X								6	6	
3	X	X	X	X			X	X	X	X	X		X	X	X	X								7	7	
4	X	X						X	X	X	X		X	X	X	X								5	5	
5	X	X	X	X				X	X	X	X		X	X	X	X								6	6	
6	X	X		X	X			X	X	X	X		X	X	X	X								6	6	
7	X	X					X	X			X	X		X	X	X	X							5	5	
8	X	X					X	X	X	X	X		X	X	X	X								6	6	
9	X	X							X	X	X		X	X	X	X								4	5	

X - Recognized consistently

Table 2  
 Touch Counting Pretest and Posttest Data

Objects counted	Student																								Total	
	Counting																								Pre	Post
	1	2	3	4	5	6	7	8	9	10	11	12	1	2	3	4	5	6	7	8	9	10	11	12		
0		X	X	X	X	X	X					X	X	X	X									5	5	
1	X	X	X	X	X	X	X	X	X	X		X	X	X	X									8	8	
2	X	X	X	X	X	X	X	X	X	X		X	X	X	X									6	7	
3	X	X	X	X			X	X	X	X	X		X	X	X	X								7	7	
4							X	X					X	X	X	X								3	3	
5							X	X		X			X	X	X	X								4	3	
6									X				X	X	X	X								2	3	
7															X	X								1	1	
8																								0	0	
9																								0	0	

X - Counted consistently

Table 3

Summary Table of Analysis of Variance-  
Numeral Recognition

Source	SS	df	MS	F
A	0.045	1	0.045	0.0065
A/S	152.58	22	6.935	
Total	152.625	23		

Table 4

Summary Table of Analysis of Variance-  
Touch Counting

Source	SS	df	MS	F
A	0.041	1	0.041	0.0046
A/S	196.917	22	8.951	
Total	196.958	23		

## **Teacher evaluation**

When it comes time to evaluate eighteen months of work one must to be open to criticism from outsiders, the future users of the product. A teacher evaluation was conducted to determine the software's usability and effectiveness. A total of five teachers participated in this evaluation. Two of these teachers had minimal experience with computers, while the rest had been exposed to computers through computer class with the students at the school, and the use of word processors. This evaluation provided constructive criticism relating to the:

- General functioning of the program (interface);
- Ease of use (sequencing of program);
- Teaching methods (number recognition and touch counting);
- Testing methods (number recognition and touch counting); and
- Use of colour, graphics, sound, animation, and digitized speech;

More specifically, the formative evaluation by teachers supplied the following information about the software:

- It's effectiveness in teaching number concepts;
- The effectiveness of digitized speech by gender and language of speech;
- The effectiveness of graphics and animations in maintaining student interest (attention at task);
- General "Bugs" in the software (functional problems); and
- Items that could be changed, added, or removed (recommendations).

### **Discussion and recommendations - teacher evaluation**

I was very surprised by the teachers' response to the program, which surpassed my expectations. In general the teachers found Multimedia Numbers to be an effective math drill that is easy to use and understand, and that is better than most other math programs they have seen. It was said that the program provided a good variety of reinforcing teaching methods, and that the testing of the concepts was well done and provided accurate results. Some teachers liked having the option to change the gender of speech, and others preferred the animations and the music. One teacher found digitized speech to be effective in teaching number concepts, in addition to the colourful screens.

All these positive comments do not mean that the teachers had no constructive criticisms to offer about the program. In fact, many valuable recommendations and suggestions were made by the teachers.

One teacher found the main menu screen very attractive, but was somewhat overwhelmed and confused by all the options. She suggested that replacing the orange earth background with a solid colour would make the menu clearer. The same teacher also suggested that digitized speech be used to tell the teacher what to do at the method selection screen and at the repetition selection screen. Furthermore, she suggested the same idea for the student, for the touch counting teaching methods four and five when the objects appear. In method four



of counting, she would prefer to have objects move from the left side of the screen to the right.

Another teacher also made interesting recommendations for the program. His first suggestion was to have numbers going from the middle of the screen to below the objects during the teaching methods three and five of counting. This would create a similar effect to the corrective method used in the testing module for counting. The second recommendation involved making boxes around the numerals in the number recognition testing module, to make the touch area more consistent. Next, he suggested that the cursor be restricted to the right side of the screen, not allowing it to cross the dividing line, in method four of touch counting. The last words of advice from this evaluator were to put writing in the white bubbles of the gender selection screen to give the user an idea of what is requested, and to replace the apple in the "HELP" icon of the main menu by a more representative one.

Only one teacher found that the digitized voice of the numeral names in method four of counting (split screen) may take the student's focus away from the numbers shown.

A few teachers recommended that the animations used in the first method of numeral recognition have the equivalent number of objects as the numeral in the animation. I found this to be a nice way of introducing numeral to group association.

The teacher evaluation sheets can be seen in appendix F.

The role of the student and the teacher in the evaluation

of the software was very important, yielding extremely valuable information for future developments in the program. Most of the recommendations made by the teachers were useful ideas, and will greatly contribute to the production of a better product.

It is important to note that during the teacher evaluation, several bugs in the program surfaced. More specifically, a memory allocation error occurred on a few occasions, one animation kept freezing, and the cursor was lost twice while trying the testing methods. No matter how long one spends in trying to debug a program, some errors will come up. It is the combination and sequence of events chosen by different users that make these bugs surface. Hopefully, all the bugs in the program will have surfaced before the program is believed to be ready for distribution.

## **Distribution**

Once the entire package is complete, comes the time to consider the marketing avenues for the product.

Due to the high costs of packaging, which includes boxes, jackets, disks, documentation, and colour printing, the common market for first time developers is shareware. The shareware market works as follows. Anyone can get a working copy of a program (complete software or limited edition) from a computer bulletin board or shareware distributor, for a minimal duplication or membership fee. Contrary to popular belief, shareware is not free. If a user likes a particular program and uses it, then he or she ought to pay the registration fee set by the program developer. The registration fee ranges from five dollars to hundreds of dollars, and usually includes a free program upgrade.

Hence, distributing Multimedia Numbers as shareware will require that: (1) the software be registered for copyright protection; (2) a list of computer bulletin boards be obtained; (3) a list of shareware distributors be obtained; (4) the various organizations be contacted for procedures to be followed.

The major drawback with using shareware as a distribution channel is that less than five percent of users register their copy of the program. Moreover, the probability of reaching the right people working with the target population

is much smaller than using educational software publishers for distribution.

The next step after offering the software as shareware will be to approach various commercial software distributors and negotiate pricing and commission for distribution.

All these procedures for distributing the software are expected to take over six months, by which time many modifications to the existing product may take place.

## **Conclusion**

The first thought that comes to mind when measuring the overall success of this endeavour, is whether the program seems to work for teachers and students. It appears that teachers believe the software will be an effective teaching tool for students with specific difficulties with number concepts. I was very pleased to see that the program appeared to create a motivating learning environment for the students, allowing them to work independently at the computer without teacher assistance or supervision. Only long term usage of the software will give a true reflection of its effectiveness in teaching number concepts, but I remain confident that students will benefit from exposure to this innovative approach to multimedia application development.

In summary, the recommendations for improvements of the software provided by the formative evaluation are as follows:

to make the main menu less busy by replacing the background picture with a uniform one; to add digitized voice where teaching methods and repetitions for teaching are selected, to indicate to the teacher what to do next; to add digitized voice to the introduction screen of teaching methods four and five of touch counting to tell the student what to do; to place numerals below objects in teaching methods three and five of touch counting to indicate total number of objects counted; to restrict cursor movement in the screen during teaching to minimize mouse movement for the student; to have the equivalent number of objects in animations as the numeral being shown in teaching method one of numeral recognition; and lastly, to add boxes around numerals for a clearer touch area in numeral recognition testing.

I began with a vision of an interactive multimedia program to teach number concepts, and as the project advanced, this vision grew bigger and bigger: first by introducing simultaneous bilingual software development; and then by offering digitized voice in both genders.

The development of the program, which spanned over two years, supplied its share of challenges. The greatest of these challenges was learning the Multimedia GRASP programming language. Even though an authoring software claims that it can do certain things, taking advantage of these marvellous features often requires a great deal of trial and error, creativity, serious thinking, and plenty of

time.

It is with great pride that I acknowledge this project as a most valuable learning experience in animation and graphic design, as well as interface design and general software development.

Reflecting on the efforts put into this project, the main regret is not having the funds to follow formal training with Paul Mace Software, the developers of Multimedia GRASP. Had I had this opportunity, this would have perhaps resulted in more effective and efficient programming, thus allowing for more attractive features in the program.

**APPENDIX A**

**Pretest Data Collection Sheet**

Student Code: \_\_\_\_\_

Age: \_\_\_\_\_

**1) Number Recognition:**

Number shown	Number type			1) Black on white 2) White on black 3) Outline number	Scoring		
	1	2	3		/3	%	
0							
1							
2							
3							
4							
5							
6							
7							
8							
9							

Number said

**2) Rote counting: X -> Number skipped** Question: Can you count for me? Start with 1 and stop when you want.

Try 1

1 2 3 4 5 6 7 8 9 10 11 12 13 14 15 16 17 18 19 20 21 22 23 24 25 26 27 28 29 30

Try 2

1 2 3 4 5 6 7 8 9 10 11 12 13 14 15 16 17 18 19 20 21 22 23 24 25 26 27 28 29 30

**3) Touch counting:**

Number shown	Presentation						Number said
	Paper Close Objects	Paper Distant Objects	Real Objects	On Computer Program 1	On Computer Program 2	On Computer MDM Numbers	
0							
1							
2							
3							
4							
5							
6							
7							
8							
9							

**APPENDIX B**

**Posttest Data Collection Sheet**

Student Code: _____
Age: _____

**1) Number Recognition:**

Number shown	Number type			1) Black on white 2) White on black 3) Outline number	Scoring		
	1	2	3		/	3	%
0					0		
1					1		
2					2		
3					3		
4					4		
5					5		
6					6		
7					7		
8					8		
9					9		

Number said

**2) Rote counting:** X -> Number skipped      Question: Can you count for me? Start with 1 and stop when you want.

Try 1  
1 2 3 4 5 6 7 8 9 10 11 12 13 14 15 16 17 18 19 20 21 22 23 24 25 26 27 28 29 30

Try 2  
1 2 3 4 5 6 7 8 9 10 11 12 13 14 15 16 17 18 19 20 21 22 23 24 25 26 27 28 29 30

**3) Touch counting:**

Number shown	Presentation						Number said
	Paper Close Objects	Paper Distant Objects	Real Objects	On Computer Program 1	On Computer Program 2	On Computer MM Numbers	
0							
1							
2							
3							
4							
5							
6							
7							
8							
9							



APPENDIX C

Numbers used for pretest and posttest.

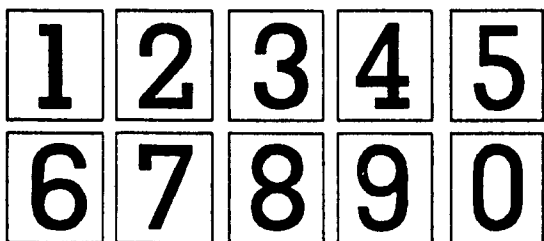

Black on White - Thin

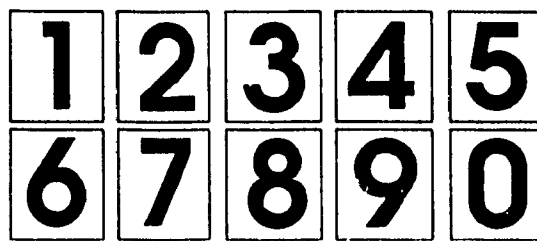

Black on White - Thick

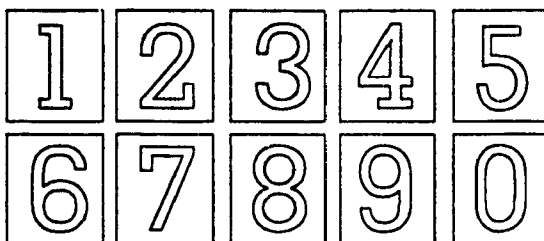

Outline - Thin

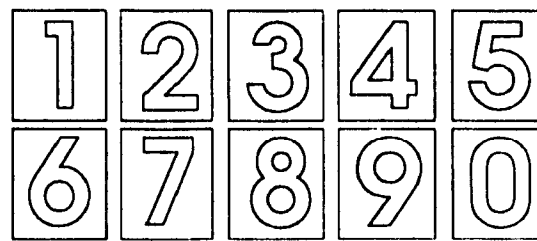

Outline - Thick

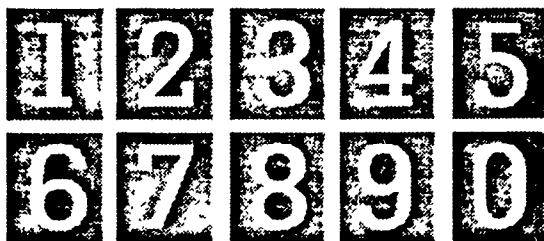

White on black - Thin

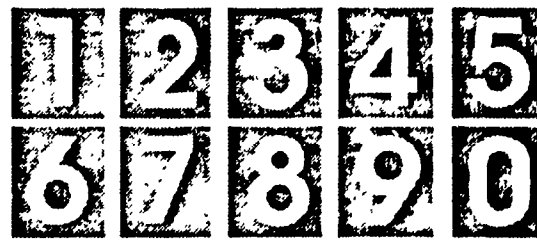

White on black - Thick

\* 32% of actual size.

APPENDIX D

Notes on Student during testing		Student Code: _____
Date: _____		
General interest in program	Behaviour so far today	
_____	_____	
_____	_____	
Any verbal responses	Other comments	
_____	_____	
_____	_____	
Attention at task	Under medication	
_____	_____	
_____	_____	
Date: _____		
General interest in program	Behaviour so far today	
_____	_____	
_____	_____	
Any verbal responses	Other comments	
_____	_____	
_____	_____	
Attention at task	Under medication	
_____	_____	
_____	_____	
Date: _____		
General interest in program	Behaviour so far today	
_____	_____	
_____	_____	
Any verbal responses	Other comments	
_____	_____	
_____	_____	
Attention at task	Under medication	
_____	_____	
_____	_____	

APPENDIX E

# Teacher Evaluation

**General Thoughts**

---

---

---

**Ease of use**

---

---

**Use of:**

**Colors**

---

---

**Digitized speech (voices)**

---

---

**Sound**

---

---

**Music**

---

---

**Graphics**

---

---

**Animation**

---

---

**Approach to teaching and testing:**

**Number recognition**

---

---

**Touch counting**

---

---

**Recommendations for changes or additions:**

---

---

---

---

Thank You

Thank You

Thank You

Appendix F

# Teacher Evaluation

Domenic D.

## General Thoughts

I like what I see, better than most of the math programs I have seen. Easy to use, reinforcing. Testing method, well done, gives accurate results.

## Ease of use

I found it easy to use - young students may find main menu a little confusing

## Use of:

### Colors

Good

### Digitized speech (voices)

Male - English - Fine

### Sound

I like the choice given  
Male or Female - " " -  
- also look at attached sheet

### Music

-

### Graphics

- seemed good

### Animation

- V. Good - I like snow plow  
- fill screen with snow

## Approach to teaching and testing:

### Number recognition

- snow  $\rightarrow$  fill screen

Teaching - Method 2 - sound may take focus away from looking at #'s - Method 2 - I like

Testing - ask to "click" is not consistent - Top Right = 5 marker  
- I may want to draw a line around #'s 10; 

11	12
13	14

### Touch counting

Teaching - Method 3  $\rightarrow$  I would either have numbers under picture or going from middle of screen to right below picture 10, 0, 0, 0

Method 5 - may have numbers under picture.

3

## Recommendations for changes or additions:

- On Vertical Touch counting - prevent the cursor from crossing mid line.
- Main Menu - apple for help - ?
- Male or Female voice  $\rightarrow$  fill in bubbles with some writing
- I lost cursor (mouse) - a few times

Thank You

Thank You

Thank You

# Teacher Evaluation

## General Thoughts

Very colorful but main menu is busy. I like the variety of teaching methods & need to coincide with availability in student's testing is good skill.

## Ease of use

straight forward! Once I got use to the mouse everything went ok. Touch window would be great.

## Use of:

### Colors

Good.

### Digitized speech (voices)

### Sound

Very clear except for some noise before sound comes on.

### Music

The tune is fine.

### Graphics

Good.

### Animation

Nice but perhaps a few more would provide more variety.

## Approach to teaching and testing:

### Number recognition

Fun method is entertaining and effective. Perhaps more animations for other methods would be nice.

### Touch counting

I am sure the students will like this counting pictures to other side. I like the text summary at end.

## Recommendations for changes or additions:

- More animations
- less rounded menu
- buy a touch window!

Hilene.

Thank You

Thank You

Thank You

# Teacher Evaluation

## General Thoughts

I think the program is easy to use. The graphics are clear and simple to understand.

## Ease of use

It was easy to navigate between option and menus and student activities.

## Use of:

### Colors

Very colorful menus

### Digitized speech (voices)

Good

### Sound

is loud enough.

### Music

Good

### Graphics

Nice

### Animation

Interesting

## Approach to teaching and testing:

### Number recognition

Appears to be effective with the lower functioning students.

### Touch counting

Innovative strategies.

## Recommendations for changes or additions:

Perhaps the main menu should be less crowded. The cursor was unresponsive - but during testing.

A. Cadogan

Thank You

Thank You

Thank You

# Teacher Evaluation

## General Thoughts

*I like the mouse!*

## Ease of use

*know you  
When you need to use mouse - its very easy!*

## Use of:

### Colors

*great! I like the way  
the letters for the words are done*

### Sound

*Nice font!  
effective*

### Graphics

*Icon for main  
menu too small! (Confusing)  
Too busy!*

### Digitized speech (voices)

*Female (I would choose female  
if it sounds like Jocelyne!)*

### Music

*Too long - same thing - varied  
music will keep interest when program  
starts*

### Animation

*Blue animation figures match #'s for  
counting!*

## Approach to teaching and testing:

### Number recognition

*More animations - 4 too few -*

### Touch counting

*effective - easy to understand*

## Recommendations for changes or additions:

*Fix the spelling error in sound file.*

Thank You

*Abby*  
Thank You

Thank You



# Teacher Evaluation

May 14

## General Thoughts

- Very good overall design - Looks fun for the students  
 - it is very simple and easy to use if a student is not  
 into it - The individual paths are a variety of lines.  
 as far as repetition dull, & boring - very well designed  
 - easy to use - I thought that the first page was not  
 very attractive, but also a little confusing. It also a  
 little complicated by all that was on the screen.

## Ease of use

### Use of:

#### Colors

EA ✓

#### Digitized speech (voices)

EA -

#### Sound

EA -

#### Music

EA -

#### Graphics

EA ✓

#### Animation

EA -

## Approach to teaching and testing:

### Number recognition

Explanation for repetition needs to be explained in more detail - more practice

### Touch counting

- Say what to do in TC - M - with object - app 123  
 - I would have to figure out the right path (not well)

## Recommendations for changes or additions:

---



---



---



---

Thank You

Thank You

Thank You

## Bibliography

- Barberger, Christine, "Les Bugs du logiciel québécois," Commerce, Octobre 1992, 112-115.
- Beaulieu, J.E., "A study of the effects of selected feedback delay intervals upon retention of science material in a computer assisted instructional task with junior high school students" (Ph.D. diss., University of Oregon) in Research Windows - Assessing the Value of Immediate Feedback for Correct Answers, ed. Betty Collis (Enschede: University of Twente, 1986), 27.
- Bruner, J., "Toward a Theory of Instruction," in Challenging Mathematics I (Laval: Mondia Editeurs, 1991).
- Canning, J., "Multimedia Authoring Tools," Infoworld Magazine, 9 March 1992, 76-77.
- Caron, J., Lepage, E., Vers un apprentissage authentique de la mathématique. Collection "Outils pour une pédagogie ouverte," in Paper presented to Jean-Marie Labrie, ed. Marie-Michèle Tousignant (University of Sherbrooke, 1990) 2-11.
- Computing Now, "Multimedia Survival Guide," October 1992, 10-22.
- Erdogmus, H., Interview by André Poirier, 7 January 1993, Montreal, Qc.
- Goodwin, L.D., Goodwin, W.L., Nansel, A., Helm, C.P. "Cognitive and affective effects of various types of microcomputer use by preschoolers." in Research Windows - Novelty in Preschoolers, ed. Betty Collis (Enschede: University of Twente, 1987), 49.
- Griswold, P.A., "Elementary Students' Attitudes During Two Years of Computer Assisted Instruction" in Research Windows - CAI Increases Academic Self-Confidence, ed. Betty Collis (Enschede: University of Twente, 1985), 23.
- Harper, J.A., Ewing, N.J., "A comparison of the effectiveness of microcomputer and workbook instruction on reading comprehension performance of high incidence handicapped children." in Research Windows - Learning disabilities and CAI, ed. Betty Collis (Enschede: University of Twente, 1986), 44.

- Hativa, N., Teper, A., "Differential effectiveness of three color treatments in learning geometric concepts via computer guided teaching," in Research Windows - Color as Significant Variable, ed Betty Collis (Enschede: University of Twente, 1989), 88.
- Jacobson, B., "The Ultimate User Interface," Byte Magazine, April 1992, 176.
- Kelleher, H.J., Mathworks, Book A (Toronto: Houghton Mifflin Canada Limited), 4-133.
- Klassen, W., Houghton Mifflin Mathematics Kindergarten - Teacher's Resources Book (Markham: Houghton Mifflin Canada Limited, 1988), T16.
- MacArthur, C.A., Haynes, J.A., "Computer assisted instruction with learning disabled students: Achievements, engagement, and other factors related to achievement." in Research Windows, ed. Betty Collis (Enschede: University of Twente, 1988), 72.
- Massey, C., Gelormino, J., "The influence of a math software on preschoolers' acquisition of mathematics: 'Rutons' in the classroom" in Research Windows - Preschoolers and Mathematics Software, ed. Betty Collis (Enschede: University of Twente, 1988), 70-71.
- Miller, Dan, "Buyers' Guide Multimedia Authoring Software," PC World, November 1991, 258-251.
- Mokros, J.R., Russell, S.J., "Learner-centered software: A survey of microcomputer use with special needs students." in Research Windows, ed. Betty Collis (Enschede: University of Twente, 1988), 72.
- Parette, H.P., Hourcade, J.J., VanBiervliet, A., " Selecting Appropriate Technology for Children with Disabilities," Teaching Exceptional Children, Spring 1993, 18-22.
- PC Magazine (Editor's note), July 1990
- Sawyer, R.J., Zantal-Wiener, K., "Emerging Trends in Technology for Students with Disabilities," Teaching Exceptional Children, Fall 1993, 70-77.
- Swigger, K.M., Swigger, B.K., "Social patterns and computer use among preschool children," in Research Window - Group vs. Individual Computer Use: Preschool Children's Preferences, ed. Betty Collis (Enschede: University of Twente, 1986), 37.

Thorman, J., Gersten, R., "Microcomputer Use in Special Education : An Empirical Investigation of Teachers' Perception." in Research Windows, ed. Betty Collis (Enschede: University of Twente, 1985), 23.

Tousignant, M., "Paper presented to Jean-Marie Labrie" (University of Sherbrooke, 1990) 2-11.

Turabian, K.L., A Manual for Writers of Term Papers, Theses, and Dissertations (Chicago: University of Chicago Press, 1987)

Vockell, E.L., Mihail, T., "Behind Computerized Instruction for Students with Exceptionalities," Teaching Exceptional Children, Spring 1993, 39-43.

West, Nick, "Multimedia design tools - Picking the right tools for interactive media," Macworld, November 1991, 195-201.