



National Library  
of Canada

Acquisitions and  
Bibliographic Services Branch

395 Wellington Street  
Ottawa, Ontario  
K1A 0N4

Bibliothèque nationale  
du Canada

Direction des acquisitions et  
des services bibliographiques

395 rue Wellington  
Ottawa (Ontario)  
K1A 0N4

Microfilm

Microfilm

## NOTICE

The quality of this microform is heavily dependent upon the quality of the original thesis submitted for microfilming. Every effort has been made to ensure the highest quality of reproduction possible.

If pages are missing, contact the university which granted the degree.

Some pages may have indistinct print especially if the original pages were typed with a poor typewriter ribbon or if the university sent us an inferior photocopy.

Reproduction in full or in part of this microform is governed by the Canadian Copyright Act, R.S.C. 1970, c. C-30, and subsequent amendments.

## AVIS

La qualité de cette microforme dépend grandement de la qualité de la thèse soumise au microfilmage. Nous avons tout fait pour assurer une qualité supérieure de reproduction.

S'il manque des pages, veuillez communiquer avec l'université qui a conféré le grade.

La qualité d'impression de certaines pages peut laisser à désirer, surtout si les pages originales ont été dactylographiées à l'aide d'un ruban usé ou si l'université nous a fait parvenir une photocopie de qualité inférieure.

La reproduction, même partielle, de cette microforme est soumise à la Loi canadienne sur le droit d'auteur, SRC 1970, c. C-30, et ses amendements subséquents.

# **EFFECT OF PRESTRESS FORCE ON SLENDER ELEMENTS**

Hamid Mobasher - Fard

A Thesis

in

The Department

of

Civil Engineering

Presented in Partial Fulfillment of the Requirements  
for the Degree of Master of Engineering at  
Concordia University  
Montreal, Quebec, Canada

April 1993

© Hamid Mobasher - Fard, 1993



National Library  
of Canada

Acquisitions and  
Bibliographic Services Branch

395 Wellington Street  
Ottawa, Ontario  
K1A 0N4

Bibliothèque nationale  
du Canada

Direction des acquisitions et  
des services bibliographiques

395, rue Wellington  
Ottawa (Ontario)  
K1A 0N4

Date: 2000-03-01

Date: 2000-03-01

**The author has granted an irrevocable non-exclusive licence allowing the National Library of Canada to reproduce, loan, distribute or sell copies of his/her thesis by any means and in any form or format, making this thesis available to interested persons.**

**L'auteur a accordé une licence irrévocable et non exclusive permettant à la Bibliothèque nationale du Canada de reproduire, prêter, distribuer ou vendre des copies de sa thèse de quelque manière et sous quelque forme que ce soit pour mettre des exemplaires de cette thèse à la disposition des personnes intéressées.**

**The author retains ownership of the copyright in his/her thesis. Neither the thesis nor substantial extracts from it may be printed or otherwise reproduced without his/her permission.**

**L'auteur conserve la propriété du droit d'auteur qui protège sa thèse. Ni la thèse ni des extraits substantiels de celle-ci ne doivent être imprimés ou autrement reproduits sans son autorisation.**

ISBN 0-315-84660-7

**Canada**

## ABSTRACT

### EFFECT OF PRESTRESS FORCE ON SLENDER ELEMENTS

**Hamid Mobasher - Fard**

The results of an experimental investigation of the behavior and the compression strength of slender steel tube under prestressing force are described. Series of tests were conducted using 20 feet (6.09 m) long straight or circularly bent steel pipes of 1.315 inches (33.4 mm) and 1.9 inches (48.3 mm) external diameter. Prestressing tendons were passed through the pipes and anchorage devices were placed at both ends allowing to introduce prestressing force by means of a jack.

Separate tests were conducted on test samples (both straight and curved) where tendons were loosely passing through pipes interior and on samples where tendons were provided with rings spaced at intervals of 1.0 feet (30.5 cm) and 1.5 feet (45.7 cm) securing almost concentric position of tendons in pipes interior or limited eccentricity  $e = 1/35$  of 1.315 in. and  $e = 1/50$  of 1.9 in. diameter of pipe. The relaxation and its effect on the prestressed pipe made of regular steel was also measured by testing regular steel bars # 3 and # 4 under tensile load.

## ACKNOWLEDGMENT

The author wishes to express his gratitude to Dr. Z . A . Zieliński for his invaluable advice and guidance throughout the research program and during the preparation of this thesis. The financial assistance provided from research grants is appreciated.

Also, the author wishes to thank his family for their endless love, support and understanding at all times.

## TABLE OF CONTENTS

<b>List of figures</b>	<b>VIII</b>
<b>List of tables</b>	<b>XI</b>
<b>Notations</b>	<b>XII</b>
<b>CHAPTER 1 - INTRODUCTION</b>	
<b>1.1 - General</b>	<b>1</b>
<b>1.2 - Member in axial tension and compression</b>	<b>1</b>
<b>CHAPTER 2 - PRECOMPRESSING AND PRESTRETCHING SYSTEMS AND THEIR ADVANTAGES</b>	
<b>2.1 - Introduction</b>	<b>5</b>
<b>2.2 - Precompressing the tension members of trusses</b>	<b>5</b>
<b>2.3 - Stays and suspension cable system</b>	<b>7</b>
<b>2.4 - Prestretched concrete column</b>	<b>9</b>
<b>2.5 - Prestretched concrete beam</b>	<b>11</b>
<b>2.6 - The ratio of the Prestress load to the strength of the bar</b>	<b>14</b>
<b>2.7 - Elongation in prestressed member</b>	<b>14</b>
<b>2.8 - Economic advantage</b>	<b>17</b>

**CHAPTER 3 - THEORETICAL ANALYSIS**

<b>3.1 - Introduction</b>	<b>20</b>
<b>3.2 - Stability of pipe during prestressing by tendon</b>	<b>20</b>

**CHAPTER 4 - EXPERIMENTAL PROGRAM**

<b>4.1 - Introduction</b>	<b>24</b>
<b>4.2 - Materials</b>	<b>28</b>
<b>4.2.1 - Steel pipes</b>	<b>28</b>
<b>4.2.2 - Steel cable</b>	<b>29</b>
<b>4.2.3 - Diaphragms</b>	<b>30</b>
<b>4.2.4 - Anchor block and chocks</b>	<b>31</b>
<b>4.3 - Instrumentation</b>	<b>32</b>
<b>4.3.1 - Strain measurements</b>	<b>32</b>
<b>4.3.2 - Load measurements</b>	<b>32</b>
<b>4.3.3 - Displacement measurements</b>	<b>33</b>
<b>4.4 - Test arrangement</b>	<b>34</b>

**CHAPTER 5 - RELAXATION TEST IN ORDINARY  
STEEL BARS**

<b>5.1 - Introduction</b>	<b>36</b>
<b>5.2 - Relaxation test program</b>	<b>36</b>

**CHAPTER 6 - TESTS RESULTS AND COMPARISON**

<b>6.1 - Stress analysis</b>	<b>38</b>
<b>6.2 - Deflection measurement</b>	<b>39</b>
<b>6.3 - Measured relaxation in ordinary steel bars</b>	<b>46</b>

**CHAPTER 7 - SUMMARY AND CONCLUSION**

<b>7.1 - Summary</b>	<b>47</b>
<b>7.2 - Conclusions</b>	<b>47</b>

<b>REFERENCES</b>	<b>49</b>
-------------------	-----------

<b>APPENDIX I</b>	<b>51</b>
-------------------	-----------



## LIST OF FIGURES

Figure		Page
1.1	- Prestretched beam and column a) Demonstration of the effect of prestressing and prestretching load on the concrete beam b) prestretched concrete column	2
1.2	- Types of cross section of bars with tendon	4
2.1	- Prestressed trusses a) prestressed single member b) prestressing the bottom chord	6
2.2	- Type of joints of members in tension	8
2.3	- Load - strain curve from prestretched column	10
2.4.1	- Stress diagram from prestressed-prestretched and prestressed concrete beam	12
2.4.2	- Stress diagram from prestretched and normal reinforced concrete beam	13
2.5	- Dependence of the ratio of elongation of a prestressed component to a non - prestressed component on parameters, K and m	16
2.6	- Mass of a prestressed component in percent of the mass of a non - prestressed component	18
2.7	- Cost of a prestressed component in percent of the cost of a non - prestressed component	19

3.1	- Typical buckling in member a) compressed at pin - end b) compressed by prestressing force, with three intermediate contact points	21
3.2	- Stressing cable with diaphragms before inserting in to the pipe	23
3.3	- Diaphragm and cable	23
4.1	- Test model as seen in plan, concentric tendon in straight pipe	24
4.2	- Test model as seen in plan, concentric tendon in bend pipe	25
4.3	- Concentric and maximum eccentric tendon position in pipe $\phi = 1.315$ in.	26
4.4	- Concentric and maximum eccentric tendon position in pipe $\phi = 1.9$ in.	27
4.5	- Diaphragms used in $\phi = 1.315$ and $\phi = 1.9$ in. pipe	30
4.6	- Anchor chock arrangements	31
4.7	- Strain gauges attached to the surface of the pipe	32
4.8	- Detail of end support and scale of measuring deformation	33
4.9	- Straight pipe of 1.9 in. diameter at the time of testing and test frame	34
4.10	- Test frame and arrangement of curved tubes from left to right, pipe of 1.9 in. diameter at the time of testing, curved pipe of 1.315 in. diameter before test and straight pipe of 1.9 in. diameter on the floor after testing and failure	35
5.1	- Relaxation test frame and bars	37
6.1	- Displacement measured at the test of straight pipe, concentric tendon position with diaphragm $\phi = 1.315$ in.	42

6.2	- Displacement measured at the test of curved pipe, concentric tendon position with diaphragm $\phi = 1.315$ in.	42
6.3	- Displacement measured at the test of straight pipe, concentric tendon position without diaphragm $\phi = 1.315$ in.	43
6.4	- Displacement measured at the test of straight pipe, maximum eccentric tendon position without diaphragm $\phi = 1.315$ in.	43
6.5	- Displacement measured at the test of straight pipe, concentric tendon position with diaphragm $\phi = 1.9$ in.	44
6.6	- Displacement measured at the test of curved pipe, concentric tendon position with diaphragm $\phi = 1.9$ in.	44
6.7	- Displacement measured at the test of straight pipe, concentric tendon position without diaphragm $\phi = 1.9$ in.	45
6.8	- Displacement measured at the test of straight pipe, maximum eccentric tendon position without diaphragm $\phi = 1.9$ in.	45
6.9	- Relaxation in percentages of initial elongation from regular reinforcing bar # 3 and # 4	46

## LIST OF TABLES

Table		Page
4.1.1	- Properties and dimension of the steel pipe $\phi = 1.315$ in.	28
4.1.2	- Properties and dimension of the steel pipe $\phi = 1.9$ in.	29
4.2	- Important properties of the cable strand used for the tests	29
6.1	- Calculated stress diagrams and deflection for pipes of $\phi = 1.315$ in.	40
6.2	- Calculated stress diagrams and deflection for pipes of $\phi = 1.9$ in.	41

## NOTATION

$A_b$	- Net cross sectional area of bar
$A_t$	- Net cross section area of tendon
$A_0$	- Total cross section area of the member
$C_b$	- Cost of an prestressed bar
$C_0$	- Total cost of an ordinary steel structure
$C_t$	- Cost of an prestressing cable strand
$e$	- Eccentricity
$E_b, E_t$	- modulus of elasticity
$f$	- Stress at failure
$f'_c$	- Concrete compression capacity
$f_{yb}, f_{yt}$	- yield strength of the bar and tendon material respectively
$f_t$	- Rupture strength of the cable strand
$I$	- Moment of inertia of the section
$L$	- Length of the member
$M$	- Moment
$P$	- Prestressing load
$R$	- Radius of bent pipe
$S$	- Section modulus
$S_t$	- Prestretching load (load transfer to the structure after cutting the cable)

$t$	- Pipe wall thickness
$T_{tot}$	- Total external tensile load
$y$	- Deflection
$Z$	- Plastic section modulus
$f$	- External pipe diameter
$\Delta_1$	- Elongation of a prestressed member
$\Delta_{1c}$	- Elongation of a non - prestressed member
$\psi_1$	- Ratio of total cross - section area of the prestressed member in comparison with non - prestressed one
$\psi_2$	- Ratio of total cost of a prestressed member in comparison with non - prestressed one

# CHAPTER 1

## INTRODUCTION

### 1.1 - GENERAL

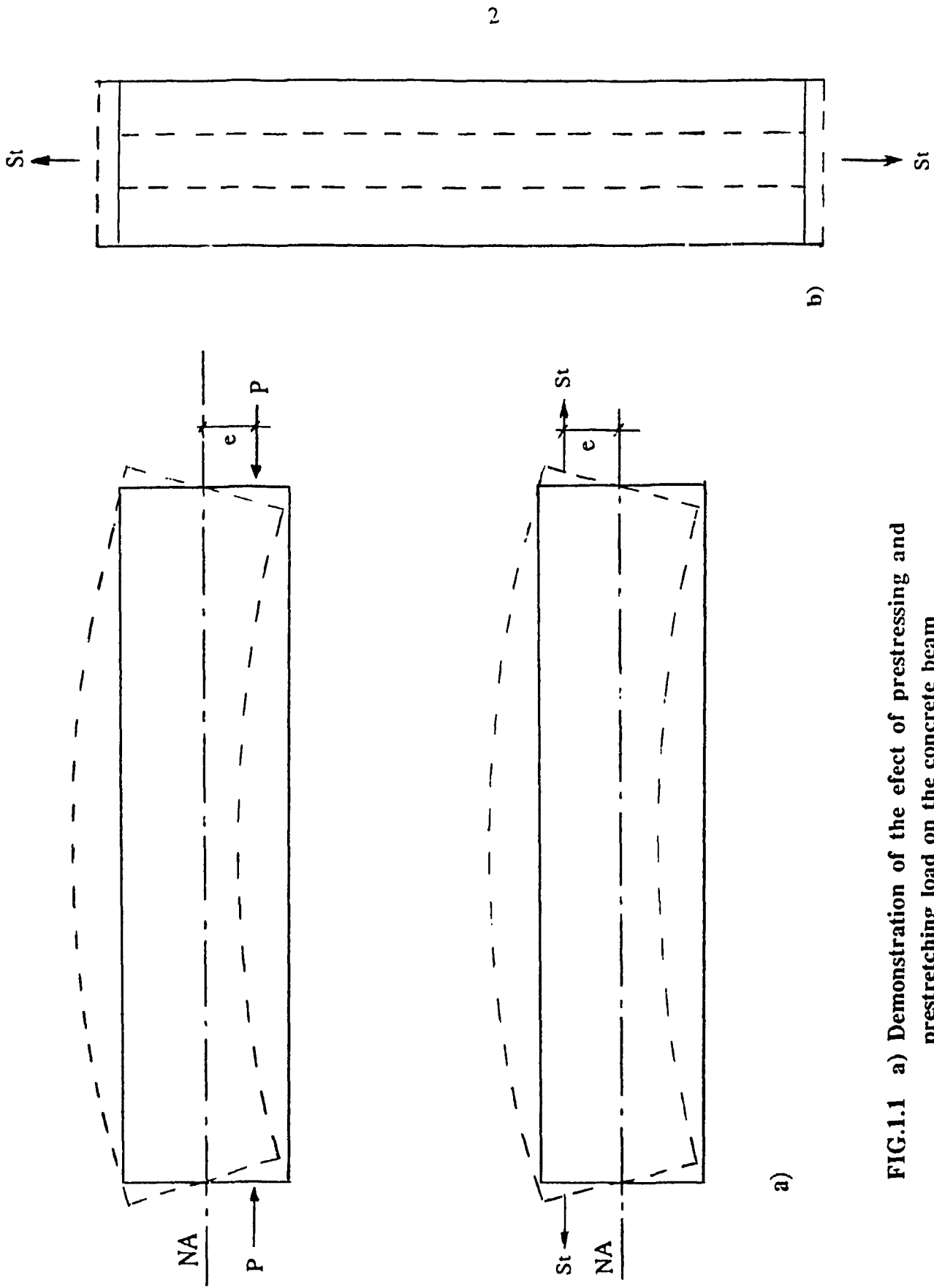
New concepts of pre-or post-tensioning of steel elements are being developed for use in strengthening of existing or design of new structural systems. The stability and behavior of such elements under effect of tensioning may be of concern particularly in slender elements made of hollow (tubular) square or round cross sections.

Such elements may be economically and structurally attractive in use for tensile truss members, stays or suspension cables made as combination of high strength steel tendon (cable) and normal strength tube, and also may be used for prestretched (opposite to prestressed) concrete beam or column.

Beam and column can be prestretched by using prestressed tube as reinforcement steel in the compression zone. After casting the concrete and during or under service load the prestressed load will relies, in order to transfer tension stresses in to the compression zone. FIG. 1.1 shows prestressed, prestretched concrete beam and column.

### 1.2 - MEMBER IN AXIAL TENSION AND COMPRESSION

Steel bars are prestressed intended for large tensile loads. Prestressed members are composed of a rigid bar from a metal of ordinary strength and a tendon from high - strength steel.



**FIG.1.1** a) Demonstration of the effect of prestressing and prestressing load on the concrete beam  
b) Prestretched concrete column



Throughout the length of the member the rigid bar is connected to the tendon by diaphragms which ensure the stability of the bar in the course of prestressing. The bar rests by diaphragms upon the tendon and remains straight under compressive load.

When the member is under tension (service load) as initially the compressive stresses in rigid bar are canceled out then the whole section (bar and cable) both are acting in tension.

Also stays or suspension cables made from a combination of regular or high strength steel bar and high strength steel cable will be economically and technically with advantageous in compare to tensile cable only.

As the use of high - strength steel in members in tension is more advantageous than that of ordinary steels, it is good practice to raise the prestressing load factor in order to transfer most passable load to the bar temporarily and finally to both the tendon and the bar. It is advisable to make the cross section of the bar symmetrical with respect to main axes of inertia FIG 1.2 shows types of cross section of bars with tendons.

Cross sections of bars may be either open or closed, in closed cross section bars the installation of diaphragms is always problem, and therefore, this type of section is suitable for shorter bars which require no reinforcing diaphragms, but as it is going to show in chapter 4 by testing a slender pipe and using diaphragms connected to the tendon and inserted in to the pipe we were able to prestress long and slender pipe. By open section the diaphragms are welded into a cross section as

transversal sheets with holes for passing the tendons.

The gaps between the edges of holes and tendon strands should be the least possible, but should allow free longitudinal motion of the tendon as it is being tensioned, to avoid any substantial friction at the points of contact.

It has to be noted that by stretching the tendon the diameter of tendon become thinner and the gap will increase.

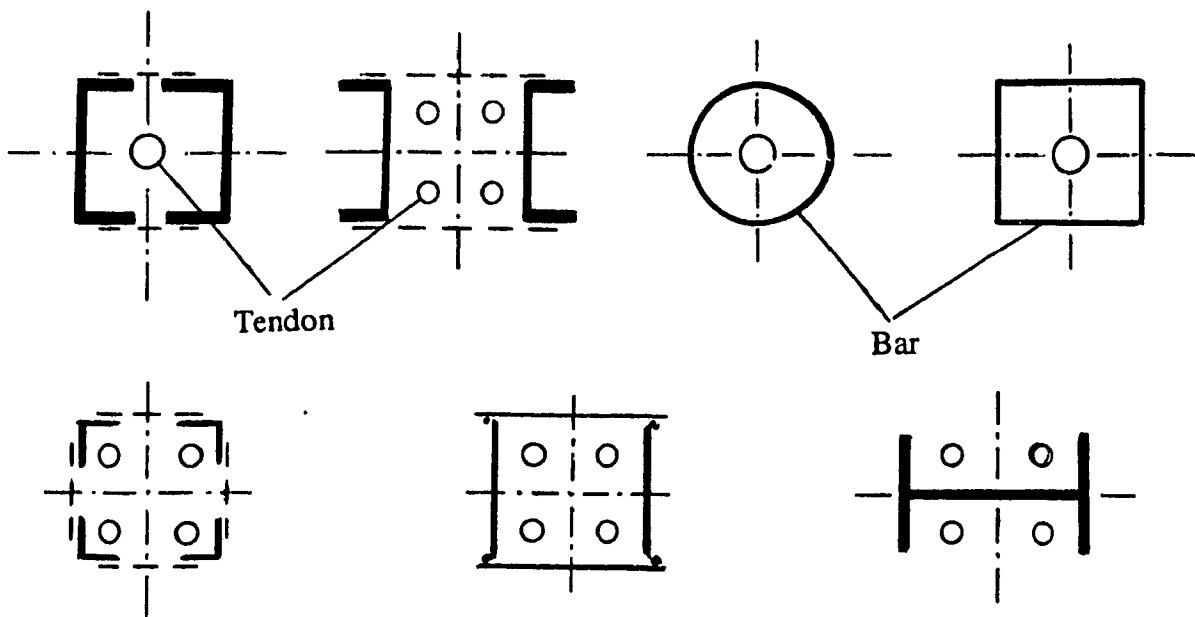


FIG. 1.2. Types of cross section of bars with tendon

## **CHAPTER 2**

### **PRECOMPRESSING AND PRESTRETCHING SYSTEMS AND THEIR ADVANTAGES**

#### **2.1 - INTRODUCTION**

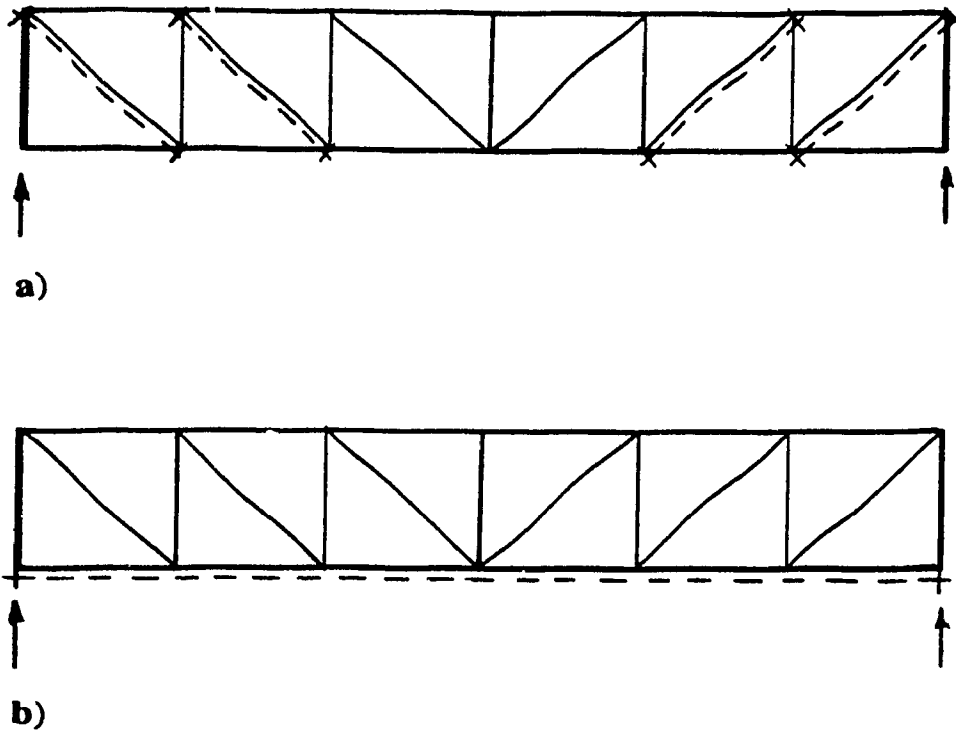
The precompressing and prestretching methods have been used to improve the load capacity of the section in steel and concrete structures. In steel structures by precompressing the tension members we are able to reduce the cross section area of the members from the view-point of lesser steel consumption and cost of structure.

Also by using precompressed steel bars in concrete column or beam and transferring the existing stresses in the bars to the concrete after releasing the wire, it is possible to increase the load capacity of the section, when we are prestretching the concrete material.

#### **2.2 - PRECOMPRESSING THE TENSION MEMBERS OF TRUSSES**

By location of tendons and their effect upon the behavior of the structure, prestressed trusses may be divided into two main types :

- a - Trusses wherein tendons are located within the limits of the most stressed bars (FIG. 2.1.a) to prestress these bars only .
- b - Trusses in which tendons are located throughout or part of the span to prestress several or all of the truss bars (FIG 2.1.b).



**FIG. 2.1. Prestressed trusses a) prestressed single member  
b) prestressing the bottom chord**

In trusses of the first type, each bar is stressed in compression by its individual tendon. Prestressed trusses of this type are effective for both large spans and loads. The bars are prestressed in the course of fabrication or during pre-assembly at the erection site.

Each of the prestressed bars may provide a saving on metal of about 40 to 45%, but the economy of metal as regards the whole of the truss is 8 to 10%, and that of the cost, 6 to 10%. The greater both the span and the load upon the truss, the larger the obtainable economy.

### **2.3 - STAYS AND SUSPENSION CABLE SYSTEM**

A combination of ordinary or high - strength steel tube with cable may be required to build tendon branches for long members of several lengths of wire rope or bars.

It can be also a composite of steel pipe and carbon tendon which is more resistible for tension load and much lighter than the high - strength steel cable. The joints are required in case of insufficient length from the tendons material or any strong materials. FIG. 2.2 shows types of joints of members in tension. The material can be joined together at the end or by the end diaphragms. The end plates should be adequately thick to resist deformation under the action of concentrated forces from the branches of the tendon.

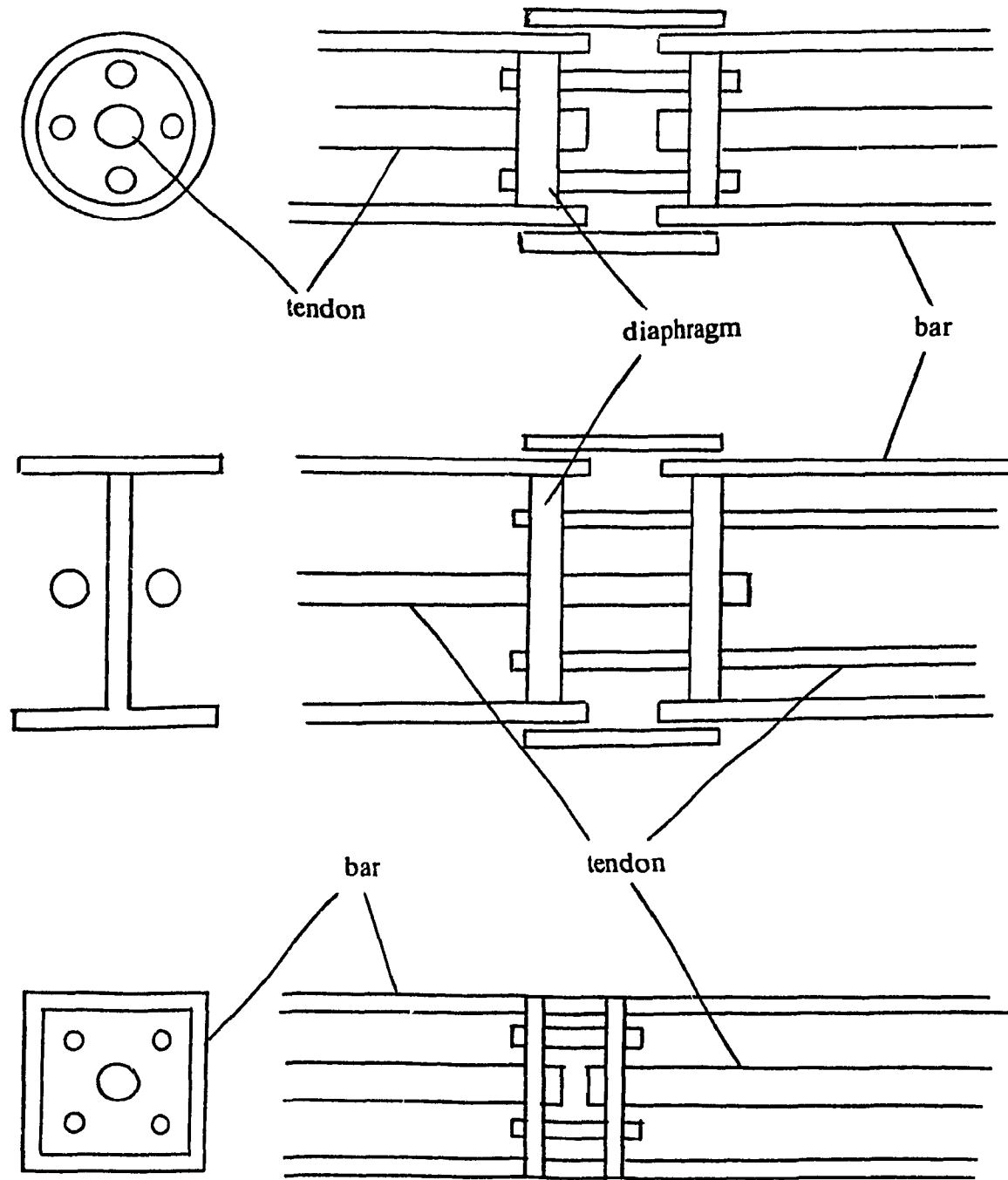


FIG. 2.2, Type of joints of members in tension

## 2.4 - PRESTRETCHED CONCRETE COLUMN

Concrete columns can be prestressed with using compressed high strength steel tubes. In conventional prestressed concrete construction, the wire is tensioned to precompress the concrete in which applied load would otherwise cause tensile stress.

In prestretched (pretensioned) concrete column which is now being considered the column will be prestressed with compressed high strength steel tubes, each of the tube with a wire passing through it, bonding the tubes to the concrete and by releasing the wire pretension or stretching the concrete. If the bond is successful the tube retains a reduced amount of compression in itself.

Billig ( 2 ) suggested the use of one large central steel tube concrete column in his investigation a column (  $f'_c = 5500 \text{ lb/ in.}^2$  ) was constructed with the high strength steel, with a maximum tensile strength of  $230\,000 \text{ lb/ in.}^2$ , was in the form of four tubes per column of  $5/16 \text{ in.}$  and each tube was stressed with  $0.214 \text{ in.}$  prestressing wire.

The column was  $3.0 \text{ in.}$  square and  $35.0 \text{ in.}$  long. Its behavior under compressive load was compared with a simple column reinforced with four unstressed tubes, a typical load - strain curve being shown in FIG .2.3 .

In practice, tension should not be allowed in the concrete and this can be avoided by releasing the wires only after sufficient external load has been applied to

the column. In the test a load of 20 Kips was applied to the column, the temporary wires were released and the concrete compressive strain fell down. The collapse load was 58 000 lb compared with 43 700 lb for the non-pretensioned column.

The increase in the strength of 14 300 lb produced by pretensioning the concrete was somewhat greater than the pretensioning force 11 500 lb. The pretension can be applied to the concrete beam also in order to increase the strength of the section.

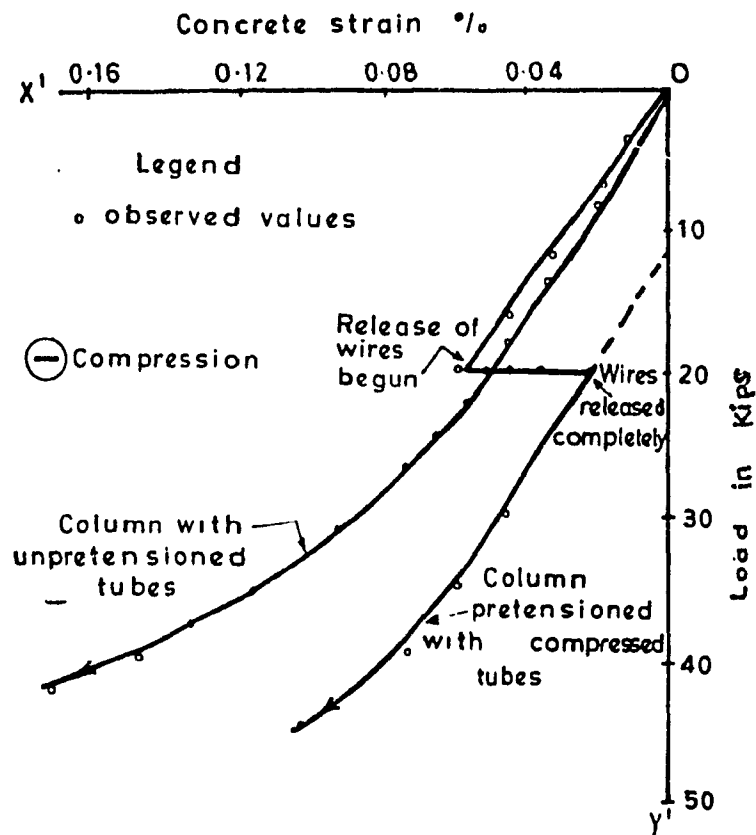


FIG. 2.3 Load - strain curve from: prestretched column



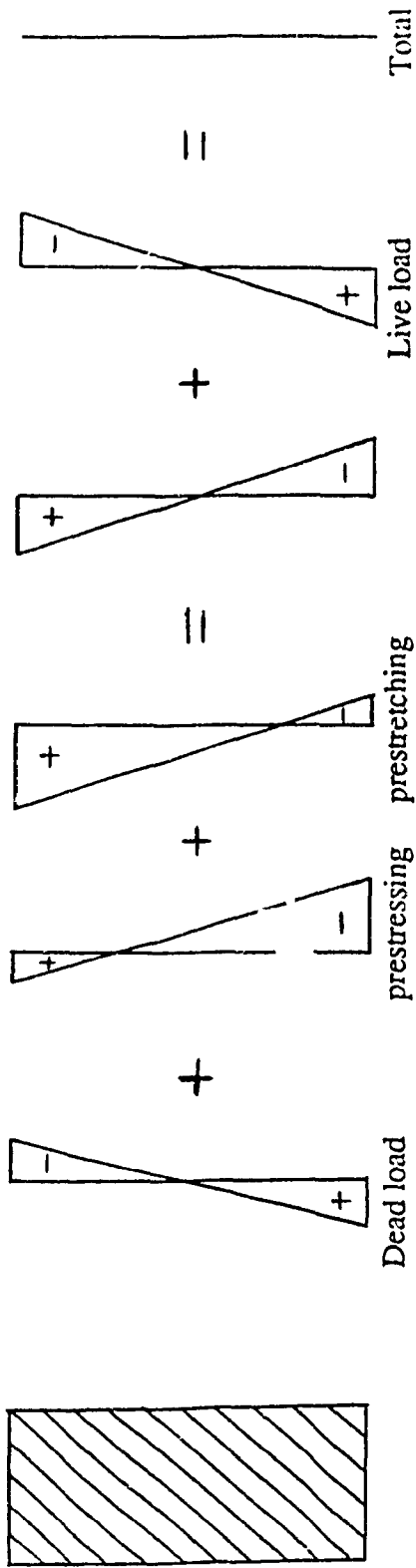
## **2.5 - PRESTRETCHED CONCRETE BEAM**

Beam can be prestretched by using regular or high strength prestressed steel tubes as reinforcement steel in the compression zone, also concrete beam can be prestressed - stretched by using cable in tension zone and prestressed steel tubes in the compression zone.

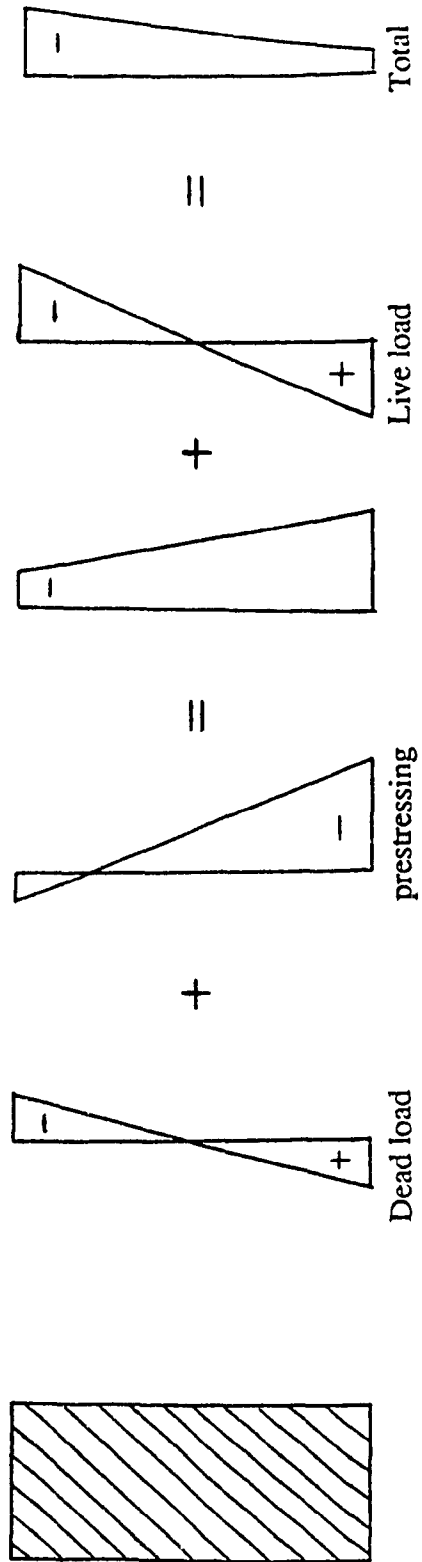
The stresses imposed on the member due to prestretching or prestressing - stretching are of opposite direction to those imposed by service load, that is the cable force normally causes small tension stresses in the top fibre and large compressive stresses in the bottom fibres and also the prestressed tubes after releasing causes tension force in the compressive fibre and compression force in the tension zone of the beam.

While the superimposed dead and live load which are to be carried by the beam cause tension stresses in the bottom fibers and compressive stresses in the top fiber. FIG. 2.4.1 shows stress diagram from prestressed - stretched beam and FIG.2.4.2 shows stress diagram from prestretched beam, and for comparison, stress diagrams from prestressed and normal reinforce concrete beam has been shown.

The prestressing cable will be released after the dead or even part of the live load has applied, the stresses in the prestressed bar mostly will be transferred to the compression zone of the concrete beam and forcing this zone to act in early loading in tension.

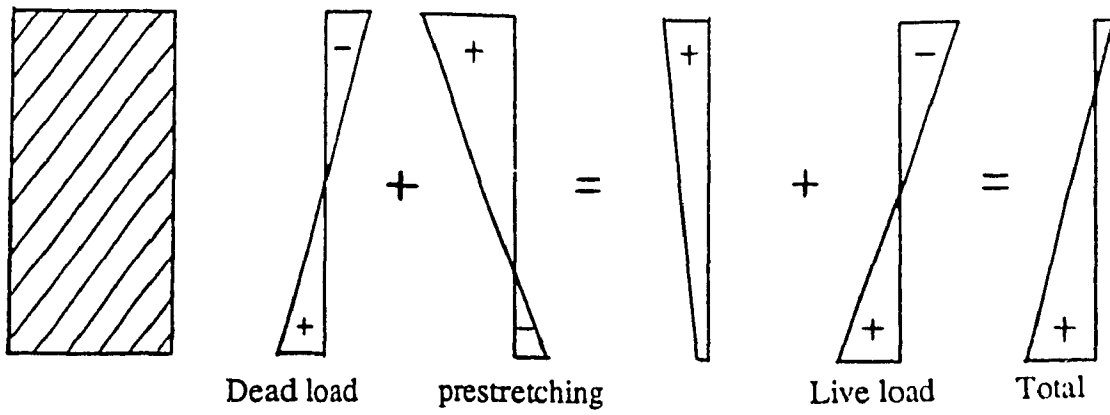


Stress diagram from a prestressed - stretched concrete beam

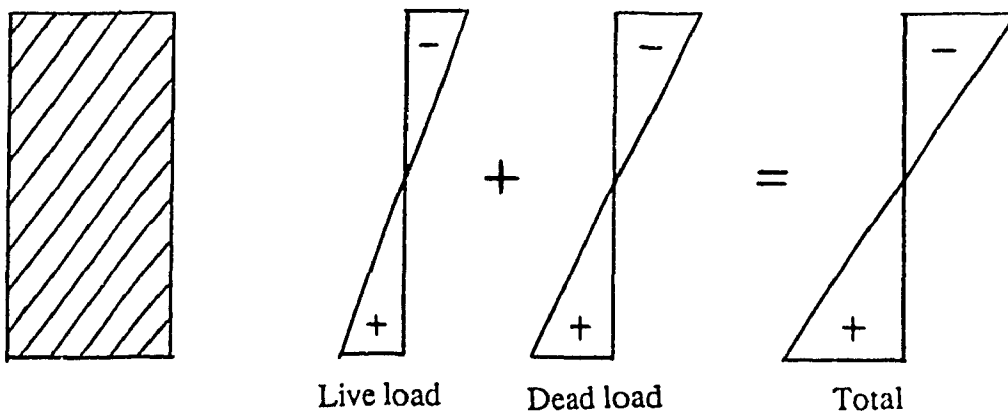


Stress diagram from prestressed concrete beam

FIG. 2.4.1 Stress diagram from prestressed - stretched and prestressed concrete beam



**Stress diagram from prestretched concrete beam**



**Stress diagram from reinforced concrete beam**

**FIG. 2.4.2 Stress diagram from prestretched and normal reinforced concrete beam**

## 2.6 - THE RATIO OF THE PRESTRESS LOAD TO THE STRENGTH OF THE BAR

The limit state of the member in tension is when the stresses in the rigid bar and in tendon attain values equal to design strengths of their materials. It is evident that the bar cross section area decreases as the prestressing force increases and instate the tendon cross section area increases.

Obviously, the ratio of the prestress to the design strength of the rigid bar  $f_b / f_{yb}$  may range from 0 to 1. Thus, by raising the value of the prestress it becomes possible to transmit the greater part of the load to the tendon and to make lighter the cross section of the rigid bar . Also, as the use of high - strength steel in members in tension is more advantageous than that of ordinary steels, it is good practice to raise the prestress value in the bar.

## 2.7 - ELONGATION IN PRESTRESSED MEMBER

Let us deduce and consider the formula that expresses the ratios of the elongation of prestressed member  $\Delta_l$  to the elongation of a non - prestressed member  $\Delta_{l0}$  :

$$\frac{\Delta_l}{\Delta_{l0}} = \frac{(f_b + f_{yb}) l E_t}{E_b f_{yt} l} = \frac{\left(\frac{f_b}{f_{yb}} + 1\right) m}{k} \quad (2.1)$$

$$\frac{\Delta_l}{\Delta_{l0}} = \frac{(f_b + f_{yb}) l E_b}{E_b f_{yb} l} = \frac{f_b}{f_{yb}} + 1 \quad (2.2)$$

Where:

$f_b$  = Value of design prestress in the rigid bar

$f_{yb}$  = Design strength of the bar material

$l$  = Length of the member

$E_b, E_t$  = Modulus of elasticity of the bar and tendon respectively

$f_{yt}$  = Design strength of the tendon material

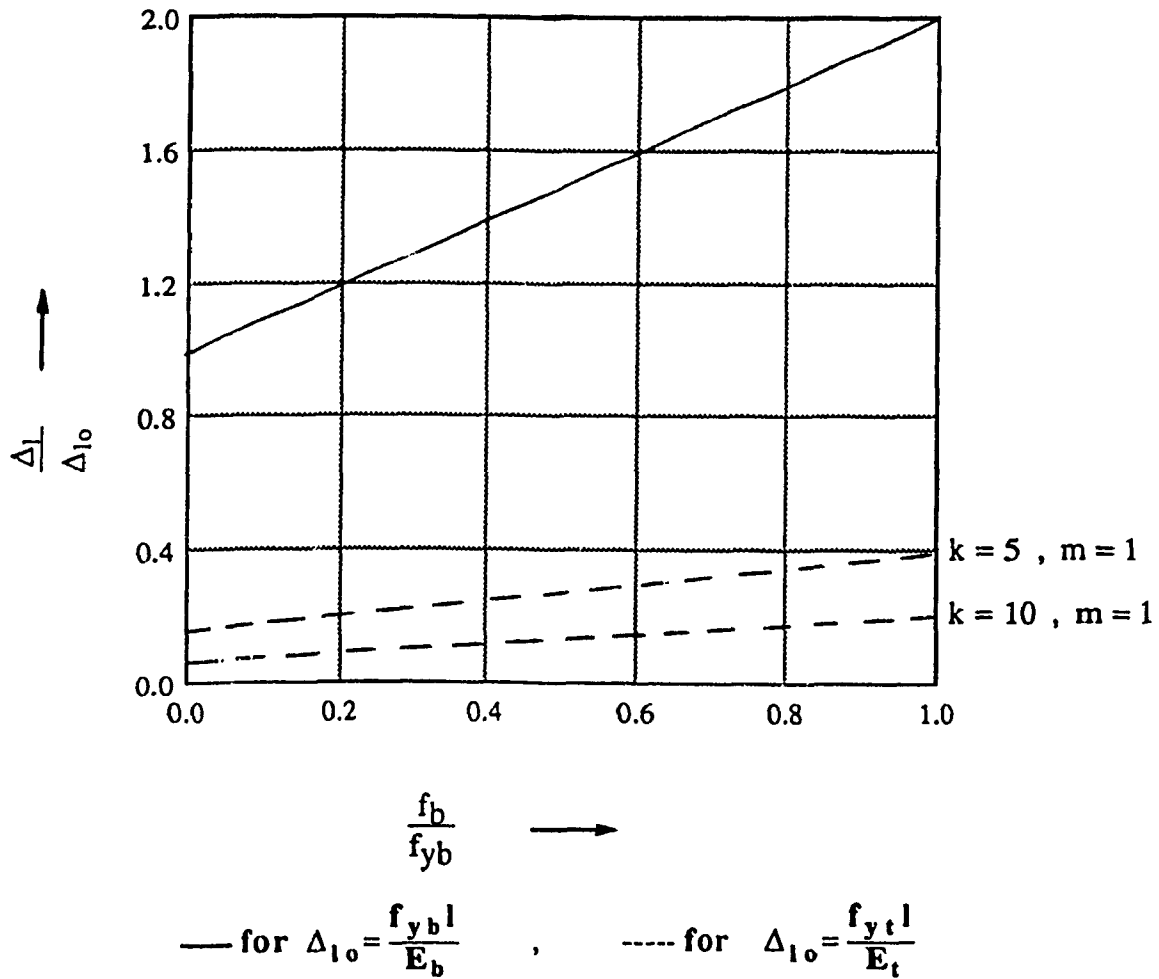
$$m = \frac{E_t}{E_b}, \quad k = \frac{f_{yt}}{f_{yb}}$$

In formula (2.1) the non - prestressed member is assumed to be from the material of the tendon  $\Delta_{l0} = (f_{yt} l / E_t)$  and in formula (2.2), from the material of the rigid bar  $\Delta_{l0} = (f_{yb} l / E_b)$ .

It can readily be inferred from diagrams FIG. 2.5 plotted to formulas (2.1) and (2.2) that the ratio  $\Delta_l / \Delta_{l0}$  grows in magnitude with the prestressing force.

When the elongation of a prestressed member is compared to the elongation of a member made fully of the material of the tendon formula (2.1) one should note a much lesser deformation value.

Thus, for  $k = 5$  the elongation of a prestressed steel member is not greater than 40% and for  $k = 10$ , is not greater than 20% of the elongation of a non - prestressed member.



**FIG. 2.5. Dependence of the ratio of elongation of a prestressed component to a non - prestressed component on parameters, K and m**

If the comparison is made with regard to a non - prestressed member from the material of the rigid bar formula (2.2), it may be noted that, when the tendon is made of any high - strength steel, the elongation of a prestressed bar cannot exceed by more than twice the elongation of non - prestressed member. The elongation of this prestressed bar is not affected by the values of the design strength and of modulus of elasticity of the tendon.

If the comparison made between high-strength steel cable which is used in stayed or suspended bridges and prestressed member from the same tendon material, the prestressed member will be more effective in the course of elongation due to service load.

## 2.8 - ECONOMIC ADVANTAGE

The economic effectiveness of a prestressed member is determined by ratio of total cross sectional area of the member or its cost to respectively cross sectional area  $A_o$  and cost  $C_o$  of the member fabricated from an ordinary material without prestressing.

$$\Psi_1 = \frac{A_b + A_t}{A_o} \quad (2.3)$$

Where:  $A_o = \frac{T_{tot}}{f_{yb}} \quad (2.4)$

$T_{tot}$  = Total external tensile load

When considering the ratio of cost of an ordinary steel structure to that of a pre stressed one:

$$\psi_2 = \frac{C_t + C_b}{C_0} \quad (2.5)$$

Formulas (2.3) and (2.5) were used to plot the diagrams FIG. 2.6 and 2.7 which show that it is advantageous to increase the prestressing force from the view-point of both lesser steel consumption and cost of structure.

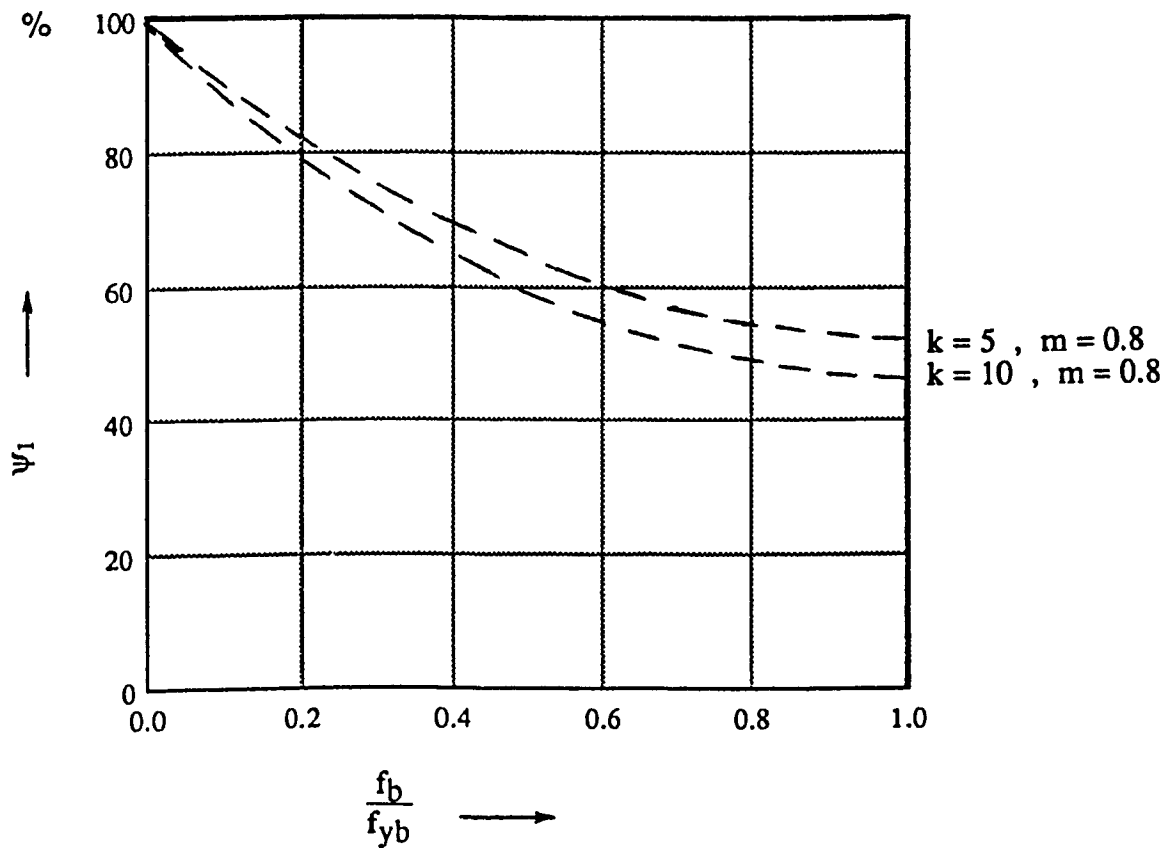
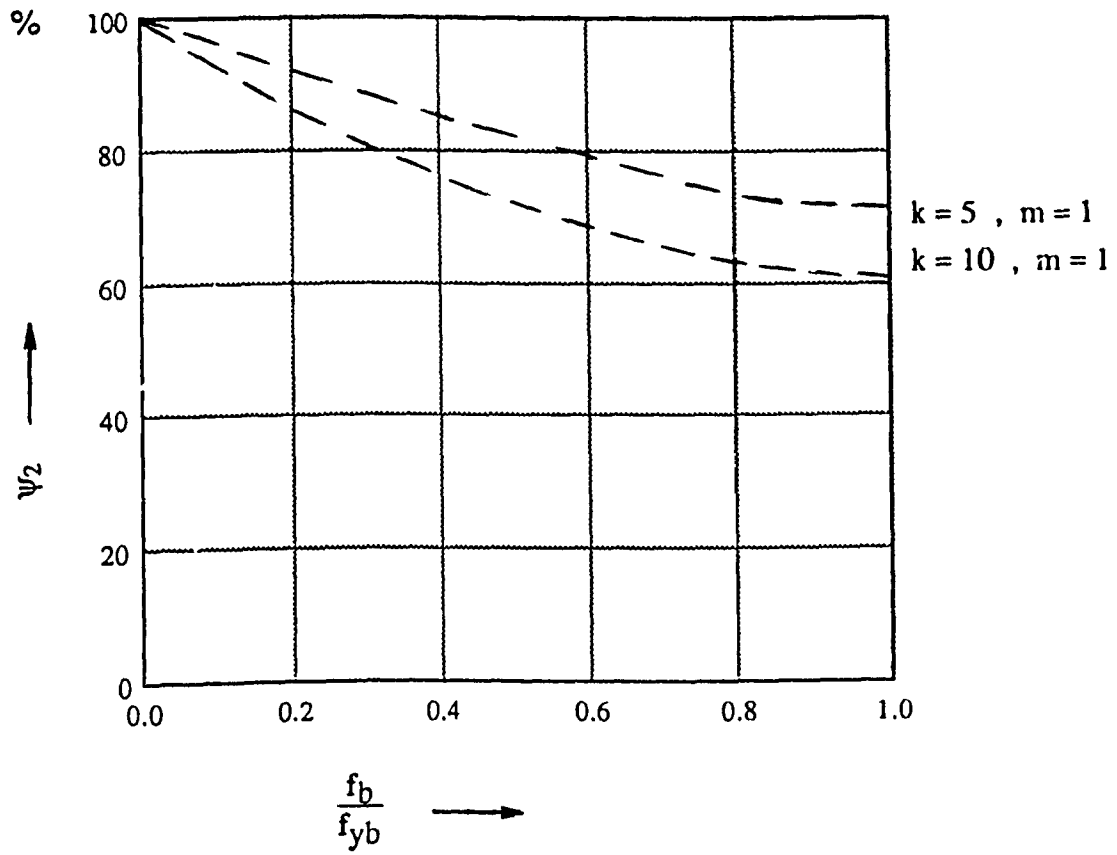


FIG. 2.6. Mass of a prestressed component in percent of the mass of non - prestressed component





**FIG. 2.7.** Cost of a prestressed component in percent of the cost of a non - prestressed component

# CHAPTER 3

## THEORETICAL ANALYSIS

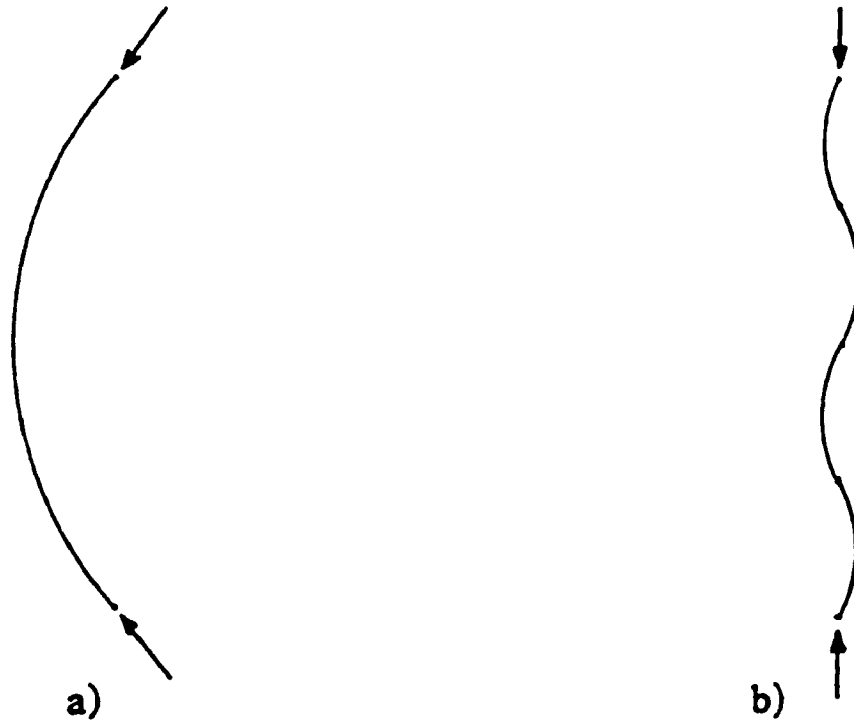
### 3.1 - INTRODUCTION

The stability of bars in course of prestressing was studied theoretically and experimentally in the former soviet union and other countries. The majority of these investigations were conducted on prestressed reinforced concrete structures, but the main regularities that have been established apply to prestressed metal as well. The calculation of the stability of a prestressed bar is based on the general regularities that govern the work of the bar against buckling.

### 3.2 - STABILITY OF BARS DURING PRESTRESSING BY TENDON

Let us consider a bar prestressed by a tendon located inside the bar along its center of gravity and touching the bar at separate points. The contact points allow common deformations of the bar and the tendon in the transversal directions and their independent deformations in the longitudinal direction.

Let's consider the Euler's buckling theory in a bar without tendon axially compressed at pin-end, FIG. 3. 1.a), and compare it with a member which was in contact points with its tendon at three intermediate places and prestressed, FIG. 3.1.b).



**FIG. 3.1 Typical buckling in member a) compressed at pin - end  
b) compressed by prestressing force, with three  
intermediate contact points**

Member with three contact points has critical Euler's force 16 times greater than the first case. In other words if a member is in contact with its tendon at  $(n-1)$  intermediate points, the Euler critical load will be  $n^2$  times greater.

Therefore the bar which has been contacted in infinite number of points can not lose its stability and the value of the limit force in the tendon is determined by the strength of the bar.

$$P = f_{yb} A_b \quad (3.1)$$

Where:

$P$  = prestressing load

$f_{yb}$  = specified yield strength of the material

$A_b$  = net cross-section area of stressed member

A loss of stability of the bar in the course of prestressing is due to the loss of stability of its individual lengths between the points of contact of the bar to the tendon. The tests described in chapter 4 were conducted in order to verify the above statement. Figures 3.2 and 3.3 shows stressing cable with diaphragms before inserting in to the pipe.

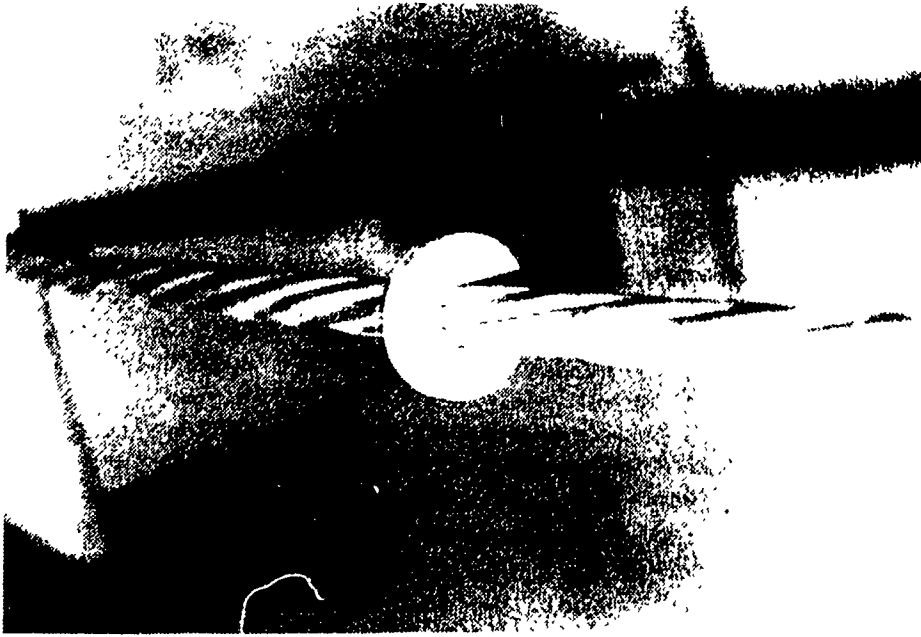


FIG. 3.3 Diaphragm and cable

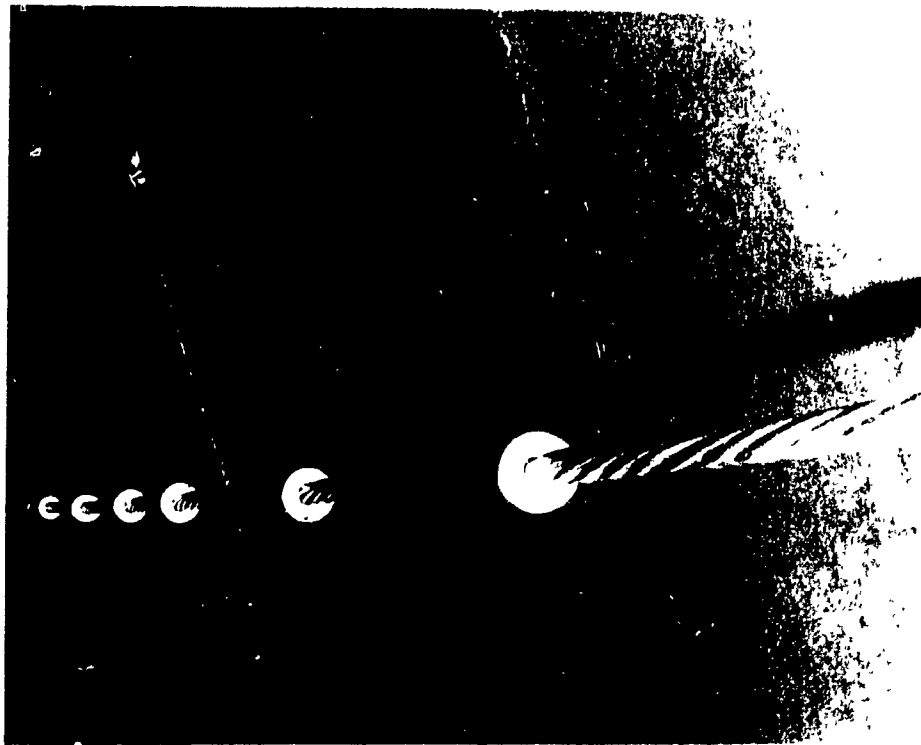


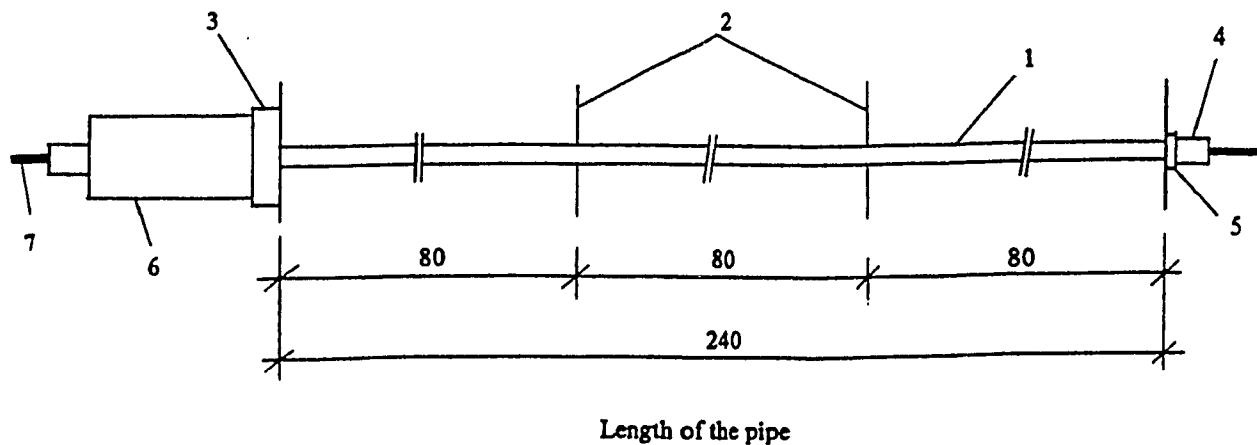
FIG. 3.2. Stressing cable with diaphragms before inserting in to the pipe

# CHAPTER 4

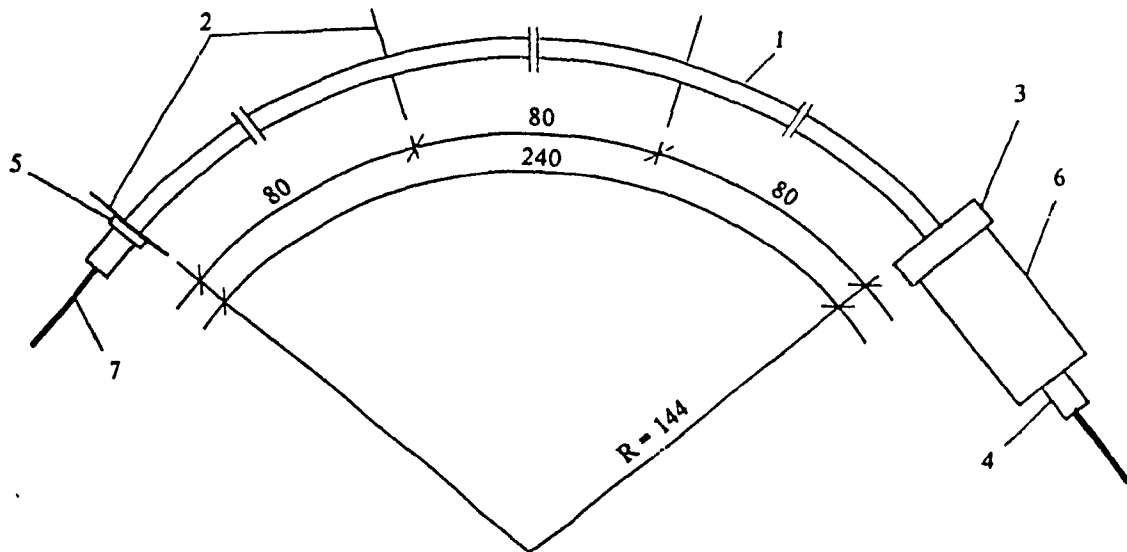
## EXPERIMENTAL PROGRAM OF PIPE TEST

### 4.1 - INTRODUCTION

The program included test in four series, of structural pipe with different tendon configurations. The first and second series consist of straight and bend ( $R = 144$  in.) pipes of 1.315 and 1.9 inches outside diameter with using diaphragms FIG. 4.1 and 4.2 shows test models.

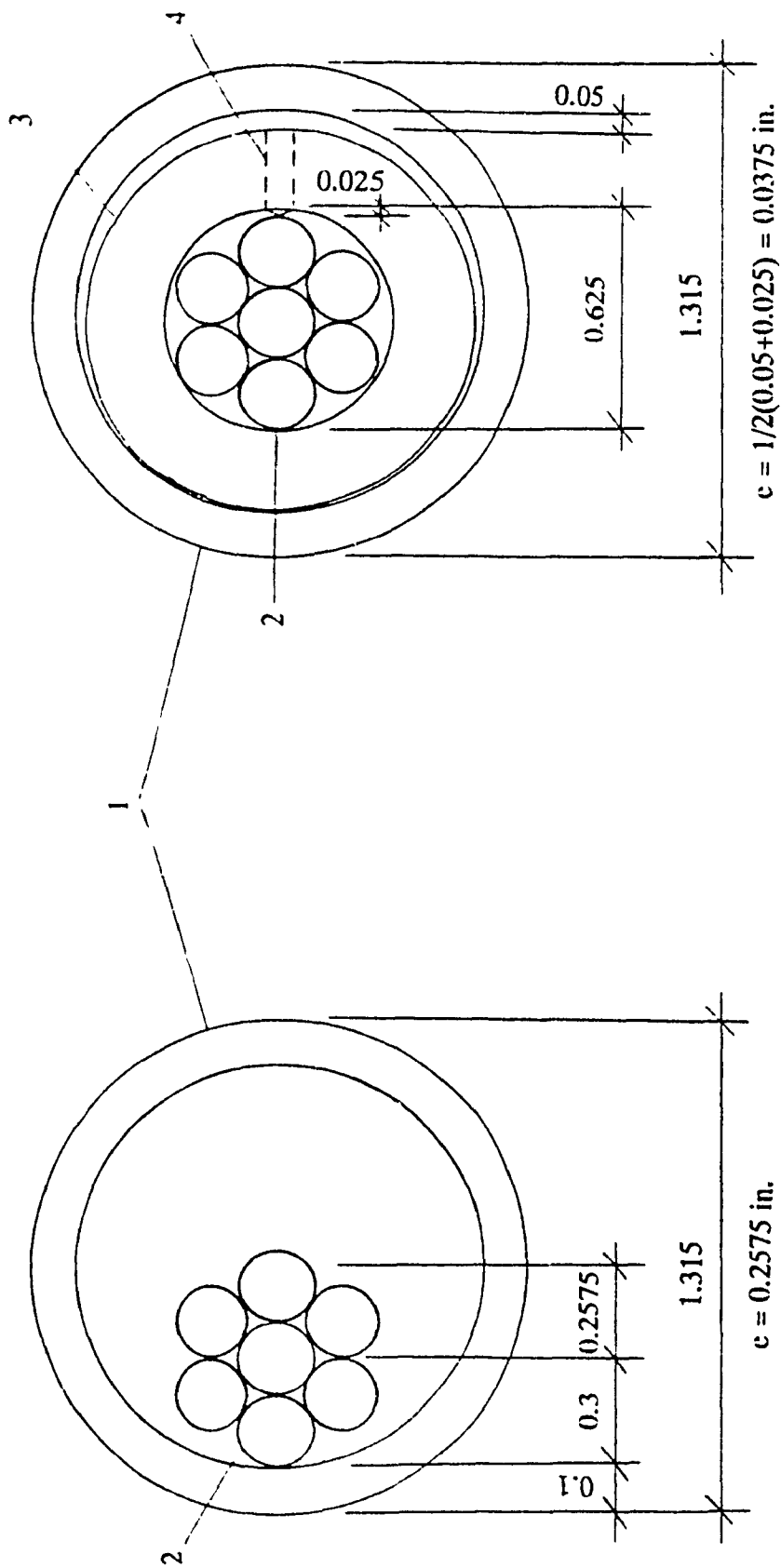


**FIG. 4.1. Test model as seen in plan, concentric tendon in straight pipe 1 - pipe 2 - supports 3 - load cell 4 - anchor 5 - endplate 6 - jack 7 - tendon**



**FIG. 4.2. Test model as seen in plan, concentric tendon in bend pipe**  
**1 - pipe 2 - supports 3 - load cell 4 - anchor**  
**5 - endplate 6 - jack 7 - tendon**

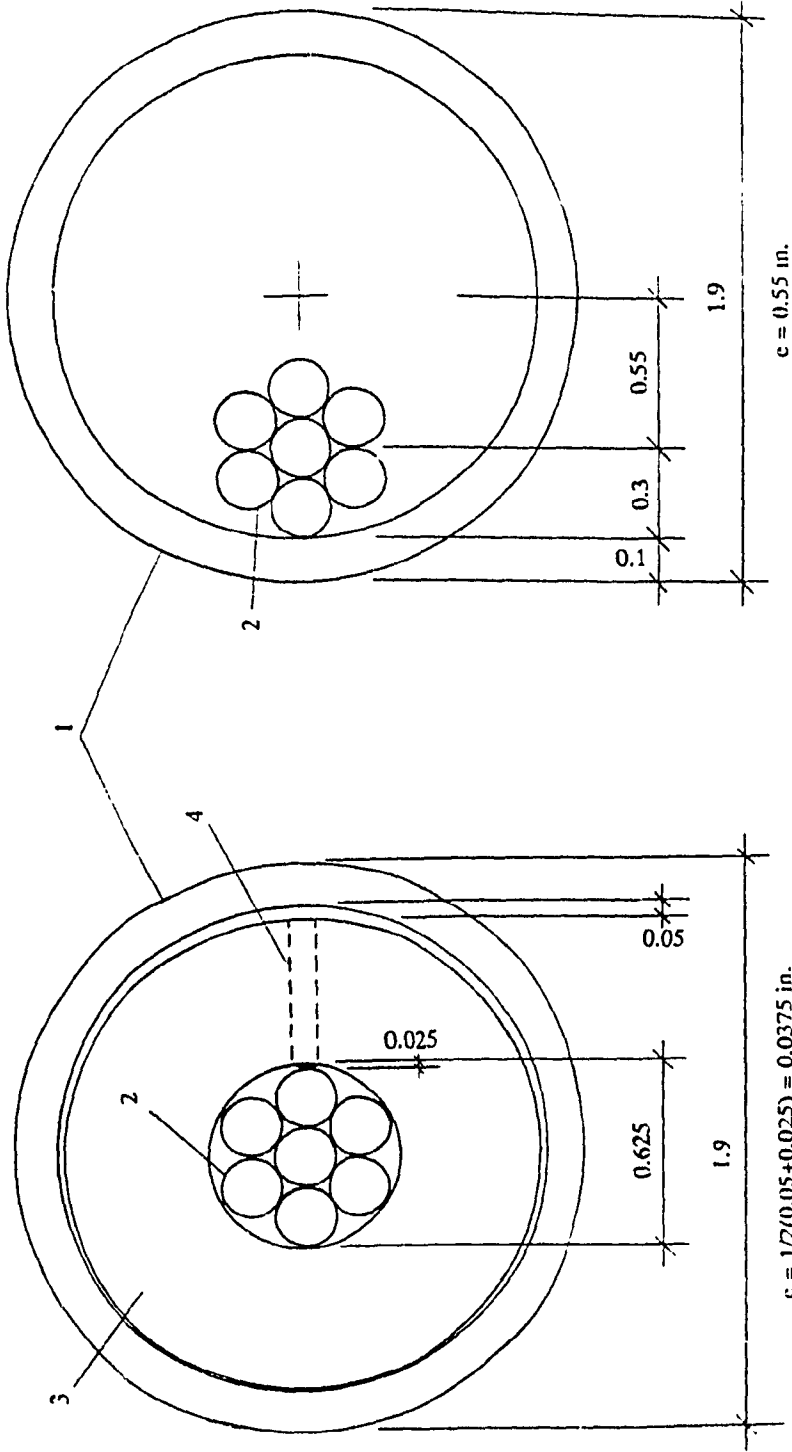
Ring - type diaphragms devices spaced at 1.5 feet (457.2 mm) intervals in larger size and 1.0 feet (304.8 mm) in smaller size were used to secure concentric position of tendon in pipes. The third and fourth series included pipes without diaphragms means tendons were loose and were able to position themselves with eccentricity, with maximum eccentricity when tendons were thatching the pipe wall. FIG. 4.3 and 4.4 shows the position of tendon in both sizes of pipe tested with and without using diaphragms and the possible eccentricity of the tendons.



- a) Prestressed member cross-section, maximum eccentricity tendon position, 1- pipe 2- tendon
- b) Prestressed member cross-section, concentric tendon position, 1- pipe 2- tendon 3- diaphragm 4- screw

**FIG. 4.3. Concentric and maximum eccentric tendon position in pipe  $\phi = 1.315$  in.**





**FIG. 4.4. Concentric and maximum eccentric tendon position in pipe  $\phi = 1.9 \text{ in.}$**

## 4.2 - MATERIALS

### 4.2.1 - STEEL PIPES

Two sizes of structural pipe were chosen:

- a)  $\phi = 1.315$  in. (33.4 mm)
- b)  $\phi = 1.9$  in. (48.3 mm)

The length of the pipes was 20 feet (609.6 Cm) and the wall thickness for all pipes was 0.1 in. (2.54 mm). Tables 4.1.1 and 4.1.2 shows the properties and dimensions of the steel pipes.

**Table 4.1.1. Properties and dimension of the steel pipe  
 $\phi = 1.315$  in.**

DEPTH	1.315 in.
THICKNESS	0.1 in.
WEIGHT	1.30 lb/ft
CROSS SECTION AREA	0.382 in. <sup>2</sup>
MOMENT OF INERTIA	0.071 in. <sup>4</sup>
SECTION MODULUS	0.108 in. <sup>3</sup>
YIELD STRESS	50 Ksi
MODULUS OF ELASTICITY	29000 Ksi

**Table 4.1.2. Properties and dimension of the steel pipe**  
 $\phi = 1.9$  in.

DEPTH	1.9 in.
THICKNESS	0.1 in.
WEIGHT	1.93 lb/ft
CROSS SECTION AREA	0.566 in. <sup>2</sup>
MOMENT OF INERTIA	0.230 in. <sup>4</sup>
SECTION MODULUS	0.242 in. <sup>3</sup>
YIELD STRESS	51 Ksi
MODULUS OF ELASTICITY	29000 Ksi

#### 4.2.2 - STEEL CABLE

The prestressing cable used for all tests were a 7 - wire strands with external diameter  $\phi = 0.6$  in. (15.24 mm). Table 4.2 shows the properties of these strand.

**TABLE 4.2. Important properties of the cable strand used for the tests**

NOMINAL DIAMETER	AREA	WEIGHT	fpu	0.7 fpu
in.	in. <sup>2</sup>	lb/ft	Ksi	Kips
0.6	0.215	0.74	250	37.6

### 4.2.3 - DIAPHRAGMS

The exterior diameter of tendon is smaller than interior diameter of pipe. To secure concentric position of tendon in pipe the ring diaphragms were used spaced at equal intervals and fixed by means of screw to the tension cable FIG. 4.5 shows the diaphragms used in  $\phi = 1.315$  and  $\phi = 1.9$  in. pipe.

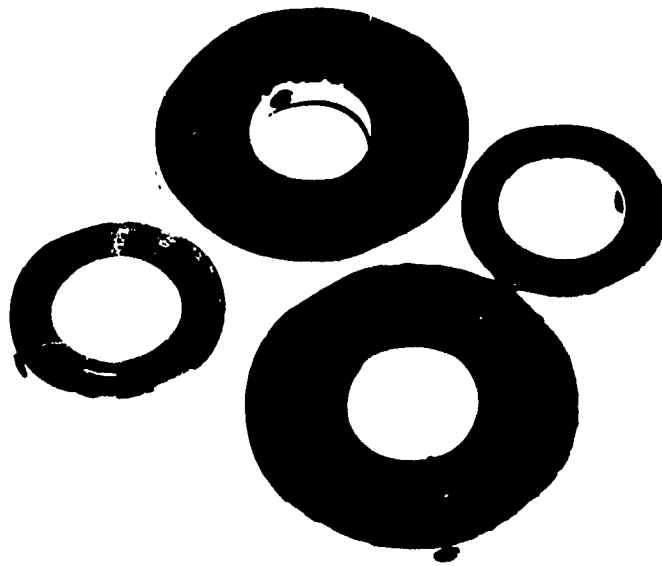


FIG. 4.5. Diaphragms used in  $\phi = 1.315$  and  $\phi = 1.9$  in. pipe

#### 4.2.4 - ANCHOR BLOCK AND CHOCKS

In order to secure tendon to the pipe and transmit to it the prestressing force, anchor chocks were positioned at both ends of the pipes. When the tendon is tensioned the pipe experiences compressive stresses. FIG. 4.6 shows the anchor chock arrangements used in these experiments.

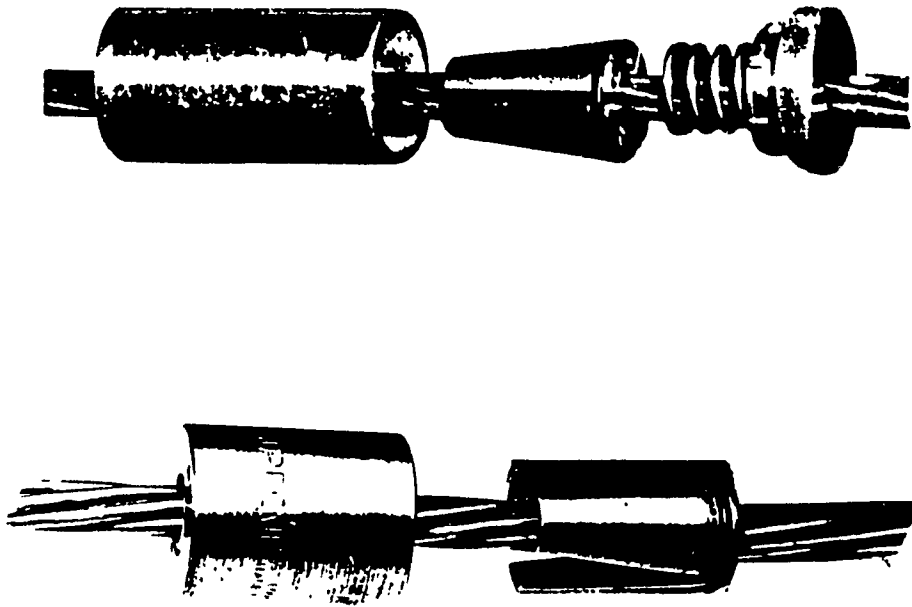


FIG. 4.6. Anchor chock arrangements

### 4.3 - INSTRUMENTATION

#### 4.3.1 - STRAIN MEASUREMENTS

This was done by means of electrical resistance strain gauges attached to the surface of pipes on four sides. FIG. 4.7 shows an example of electric strain gauges connected to the pipe.



FIG.4.7. Strain gauges attached to the surface of pipe

#### 4.3.2 - LOAD MEASUREMENTS

The applied load at end of the pipe measured by using a electronic load cell. The load cell placed directly after the prestress jack for stress control in each stage of loading.

### 4.3.3 - DISPLACEMENT MEASUREMENTS

Displacement were measured in two intermediate places and the end of the pipes. FIG. 4.8 shows the end support and scale of measuring deformation.



**FIG. 4.8. Detail of end support and scale of measuring deformation**

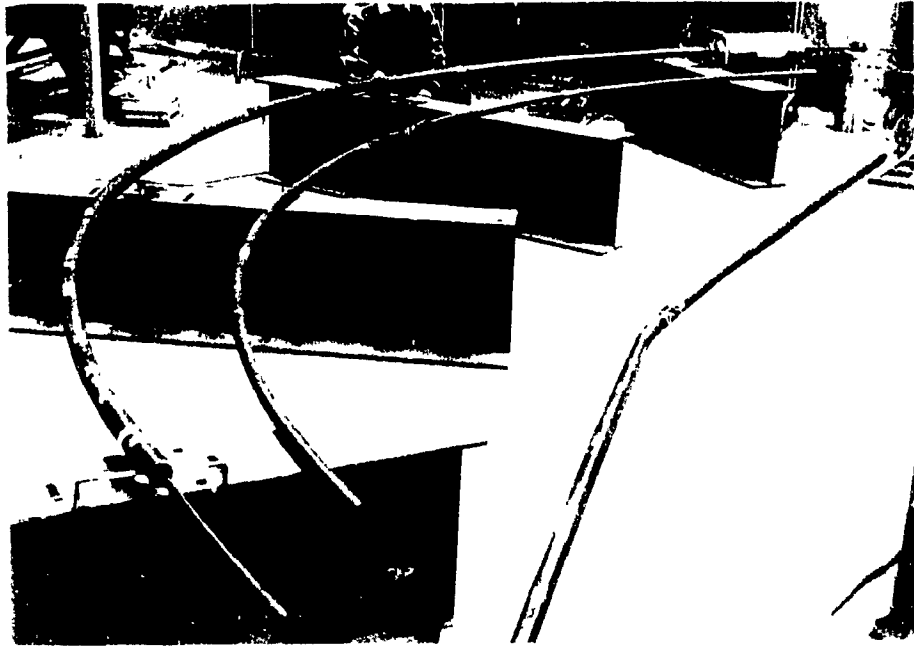
#### 4.4 - TEST ARRANGEMENT

The pipes were tested in horizontal position on the top of four I beams in 80 inches distance from each other. The jack placed on one end of the pipe and the other end was free to arbitrary deformation. FIG. 4.9 and 4.10 shows the test frame and test arrangement of straight and curved pipes.



**FIG. 4.9. Straight pipe of 1.9 in. diameter at the time of testing and supports**





**FIG. 4.10.** Test arrangement of tubes from left to right, pipe of 1.9 m diameter at the time of testing, curved pipe of 1.315 m diameter before test and straight pipe of 1.9 in. diameter on the floor after testing and failure.

## **CHAPTER 5**

### **RELAXATION TEST IN ORDINARY STEEL BARS**

#### **5.1 - INTRODUCTION**

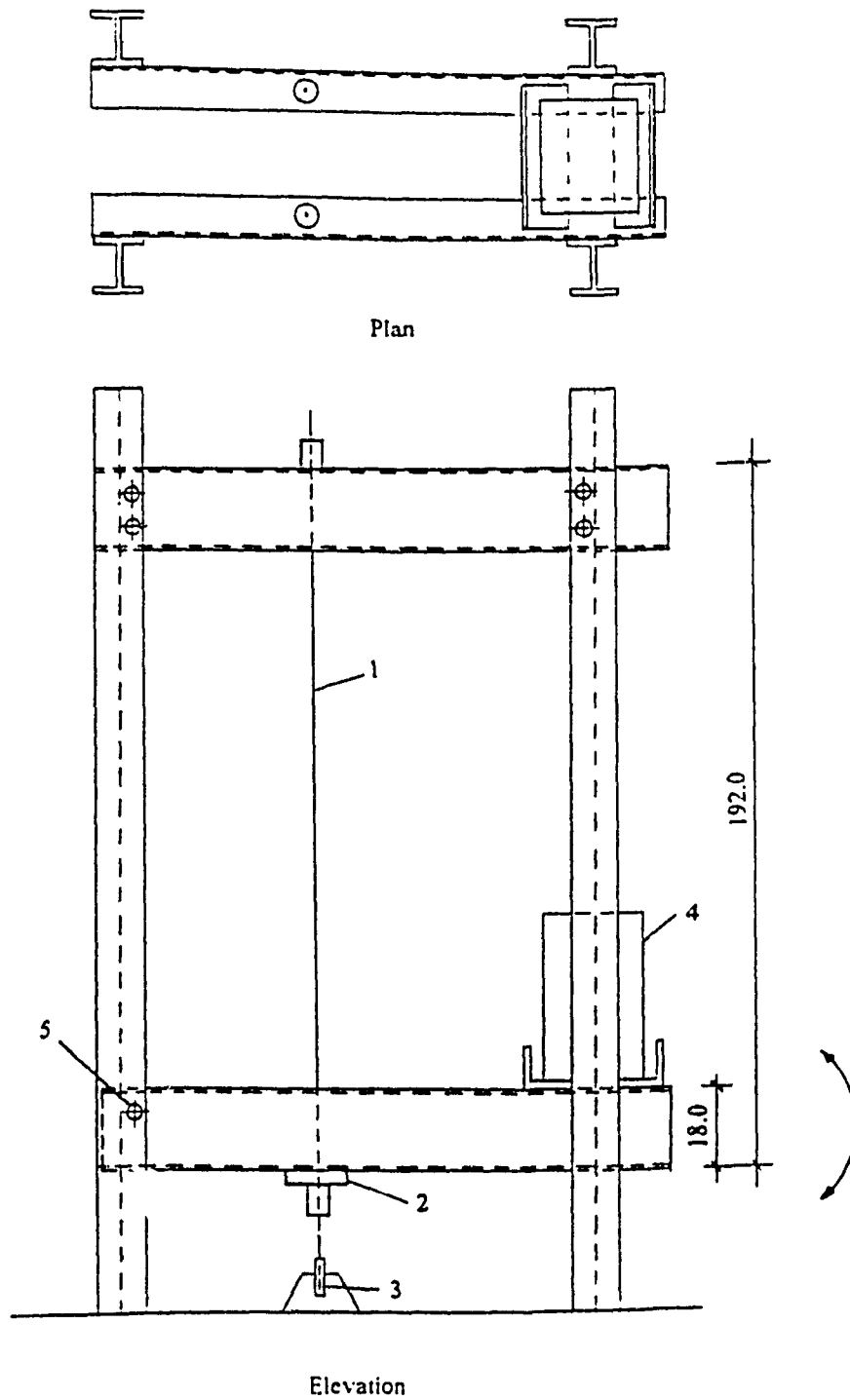
The loss of prestress force due to relaxation was investigated and is known for tendons made from high - strength steel, but the relaxation loss in ordinary steel remains to be measured. In this case study the loss of prestress force in tendon and in structural steel pipe should be considered.

Two size of steel bars # 3 and # 4 (9.52 and 12.7 mm outside diameter) were tested for relaxation under constant stress of approximately 60% of yield strength of the steel bars.

#### **5.2 - RELAXATION TEST PROGRAM**

Two size of steel bars were tested the average yield strength of bar # 3 tested was 57.5 Ksi (396.5 Mpa) and 45.0 Ksi (310.3 Mpa) for size # 4 .FIG. 5.1 shows the test frame used for the test and bars under load.

The bar's elongation was measured by electronic displacement gauge located under the bar and gives the possibility to measure the initial elongation which occur immediately after applying the load ,than after the elongation due to relaxation in the bars . The load cell was used at the end of the bar to control the constant load in the steel bars.



**FIG. 5.1** Relaxation test frame and bars in drawing (dimention in inches) 1 - bar 2 - loadcell 3 - electronic displacement gage 4 - load 5 - pin

# CHAPTER 6

## TEST RESULTS AND COMPARISON

### 6.1 - STRESS ANALYSIS

The cross sectional stresses in pipes under prestressing force were analyzed in two ways, elastic and plastic stress distribution as follow:

a) elastic stress distribution

$$f_{1,2} = \frac{P}{A} \pm \frac{Pe}{S} \quad (6.1)$$

b) plastic stress distribution

$$f_{1,2} = \frac{P}{A} \pm \frac{Pe}{Z} \quad (6.2)$$

Where:

- P** = Prestressing load (at failure)
- A** = Net cross-section area of pipe
- S** = Pipe's section modulus
- Z** = Pipe's plastic section modulus
- e** = Eccentricity of tendon positioning

Calculated stresses are presented in Tables 6.1 and 6.2 for smaller and bigger size pipes, respectively. Also, the calculated moment due to eccentricity of tendon, and the corresponding deflections due to moment are presented.

The deflection due to moment can be established as:

$$y = \frac{5ML^2}{48EI} \quad (6.3)$$

Where:

$$M = P e$$

L = Length of the pipe

E = Pipe's modulus of elasticity

I = Pipe's moment of inertia

## 6.2 - DEFLECTION MEASUREMENT

The deflections in different stages of loading were measured and shown in FIG. 6.1 to 6.8. The deflection due to moment calculated by formula (5.3) in each stage of loading included in Table 6.1 and 6.2 to have a comparison between measured and calculated deflection.

Test condition $f_y = 50$ Ksi $A = 0.382$ in. <sup>2</sup>	Eccentricity in.	Pipe diameter $\phi = 1.315$ in. pipe thickness $t = 0.1$ in.	P Load at failure (Yield) Kips	Elastic stress distribution at failure						Plastic stress distribution at failure						Moment due to eccentricity $M = P e$ Kips - in.	Deflection due to moment calculated in.	Deflection due to moment measured in.
				$\frac{P}{A}$ Ksi	$\frac{P e}{S}$ Ksi	$f_{min}$ Ksi	$f_{max}$ Ksi	$f_{min}$ Ksi	$f_{max}$ Ksi	$\frac{P}{A}$ Ksi	$\frac{P e}{Z}$ Ksi	$f_{min}$ Ksi	$f_{max}$ Ksi	$f_{min}$ Ksi	$f_{max}$ Ksi			
Concentric tendon in straight pipe with diaphragms	$e = 0.0375$ Due to gap between tendon, diaphragms and pipe		15.0		34.06	44.48		39.27	39.27		38.22	38.22		38.22	38.22	0.86	1.64	1.22
Concentric tendon in curved pipe with diaphragms	$e = 0.0375$ Due to gap between tendon, diaphragms and pipe		14.6		33.15	43.29		38.22	38.22		3.67	3.67		3.67	3.67	0.84	1.6	1.3
Concentric tendon in straight pipe without diaphragms	$e = 0.2575$ As soon as the pipe is under pressure the eccentricity becomes maximum		9.9		2.31	49.52		25.92	25.92		17.22	17.22		17.22	17.22	0.86	7.43	5.9
Maximum eccentric tendon in straight pipe without diaphragms	$e = 0.2575$		11.0		2.56	55.02		28.79	28.79		19.14	19.14		19.14	19.14	0.96	8.25	8.57

Table 6.1 Calculated stress diagrams and deflection for pipes  $\phi = 1.315$  in.

Test condition $f_y = 51$ Ksi $A = 0.566$ in. <sup>2</sup>	Eccentricity in.	Pipe diameter $\phi = 1.9$ in. pipe thickness $t = 0.1$ in.	Load at failure P (Yield) Kips	Elastic stress distribution at failure					Plastic stress distribution at failure					Deflection due to moment calculated in.	Deflection due to moment measured in.					
				$\frac{P}{A}$ Ksi	$\frac{Pc}{S}$ Ksi	$f_{min}$ Ksi	$f_{max}$ Ksi	$f_{min}$ Ksi	$f_{max}$ Ksi	$\frac{P}{A}$ Ksi	$\frac{Pc}{Z}$ Ksi	$f_{min}$ Ksi	$f_{max}$ Ksi			$f_{min}$ Ksi	$f_{max}$ Ksi	$f_{max}/f_y$	Moment due to eccentricity M - P e Kips - in.	
Concentric tendon in straight pipe with diaphragms	$e = 0.0375$ Due to gap between tendon, diaphragms and pipe		25.0										0.94	44.17	2.88	47.05	41.29	0.92	0.93	1.37
Concentric tendon in curved pipe with diaphragms	$e = 0.0375$ Due to gap between tendon, diaphragms and pipe		24.07										0.91	42.53	2.78	45.31	39.75	0.89	0.9	1.7
Concentric tendon in straight pipe without diaphragms	$e = 0.55$ As soon as the pipe is under pressure the eccentricity becomes maximum		14.3										1.1	25.26	24.2	49.46	1.06	0.97	7.86	3.2
Maximum eccentric tendon in straight pipe without diaphragms	$e = 0.55$		13.0										1.03	22.97	22.0	44.97	0.97	0.88	7.15	6.00

Table 6.2 Calculated stress diagrams and deflection for pipes  $\phi = 1.9$  in.

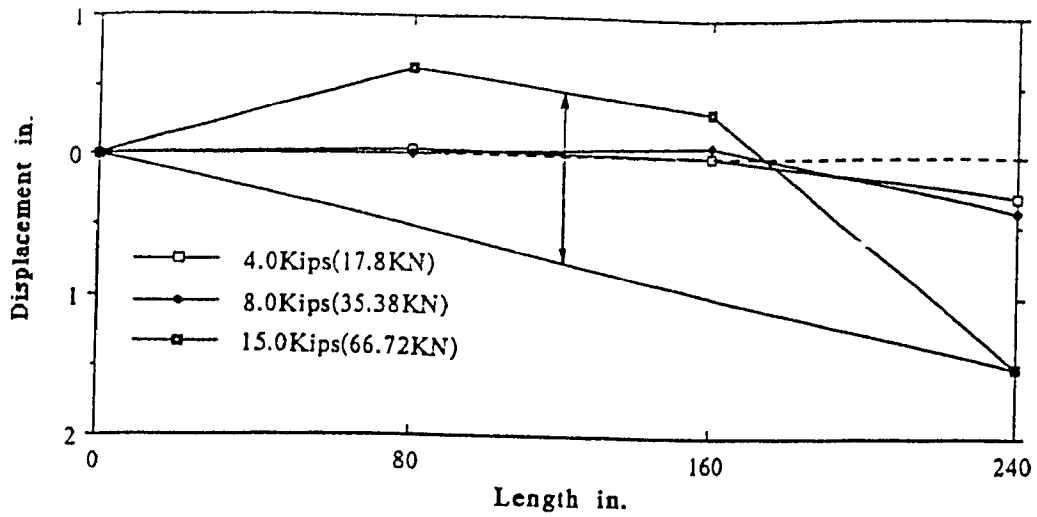


FIG.6.1. Displacement (deformation) measured at test of straight pipe, concentric tendon position with diaphragm  $\phi = 1.315$  in.

Measured deflection  $y = 1.22$  in.

Calculated deflection  $y = 1.64$  in.

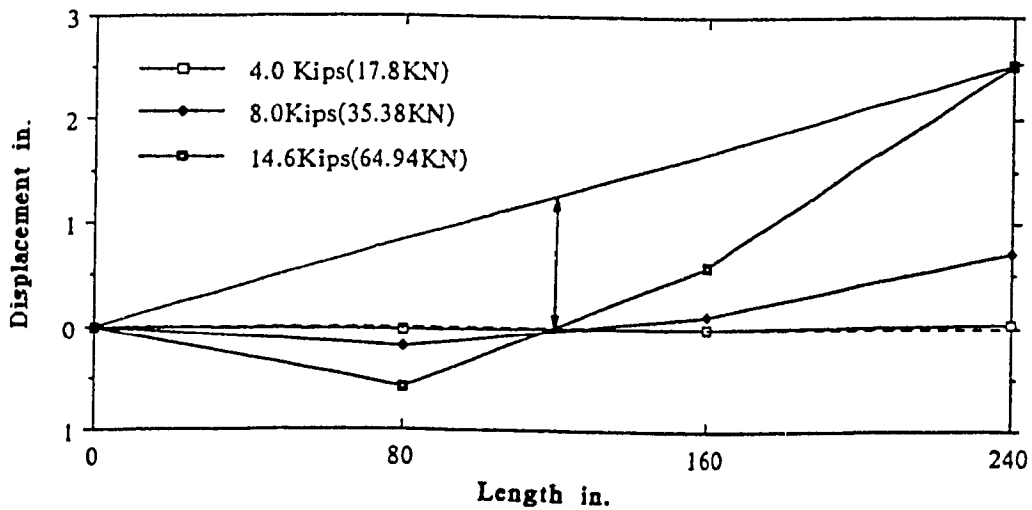


FIG.6.2. Displacement (deformation) measured at test of curved pipe, concentric tendon position with diaphragm  $\phi = 1.315$  in.

Measured deflection  $y = 1.3$  in.

Calculated deflection  $y = 1.6$  in.



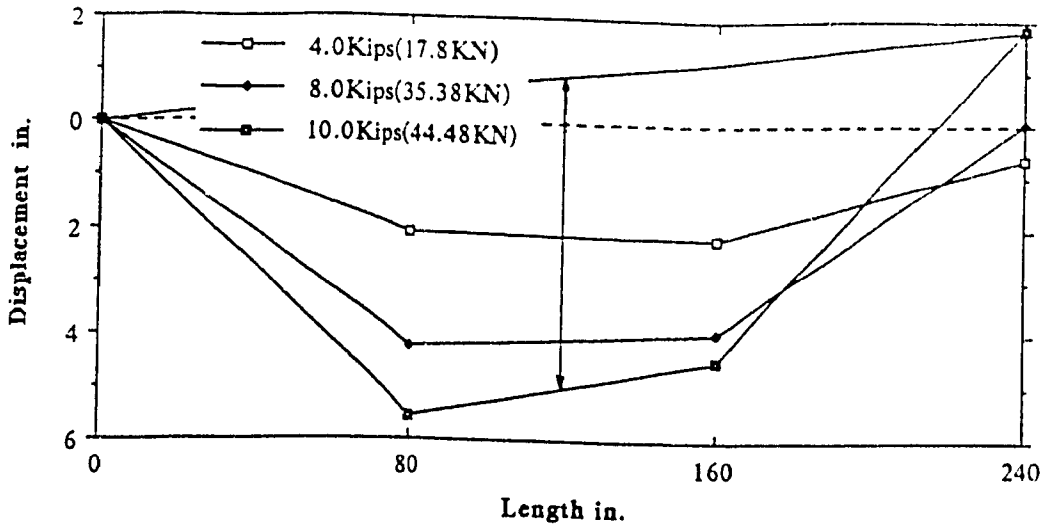


FIG.6.3. Displacement (deformation) measured at test of straight pipe, concentric tendon position without diaphragm  $\phi = 1.315$  in.  
 Measured deflection  $y = 5.9$  in.  
 Calculated deflection  $y = 7.43$  in.

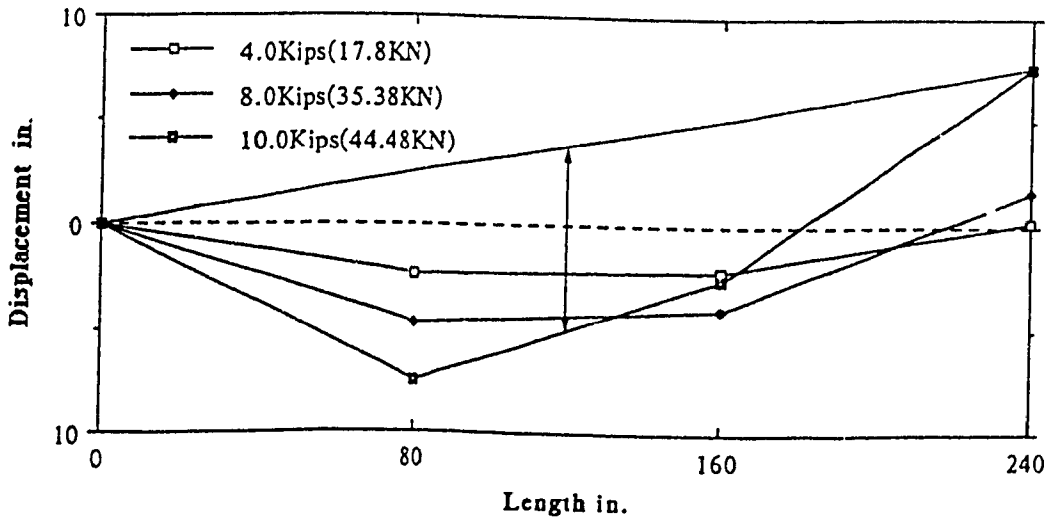


FIG.6.4. Displacement (deformation) measured at test of straight pipe, maximum eccentric tendon position without diaphragm  $\phi = 1.315$  in.  
 Measured deflection  $y = 8.57$  in.  
 Calculated deflection  $y = 8.25$  in.

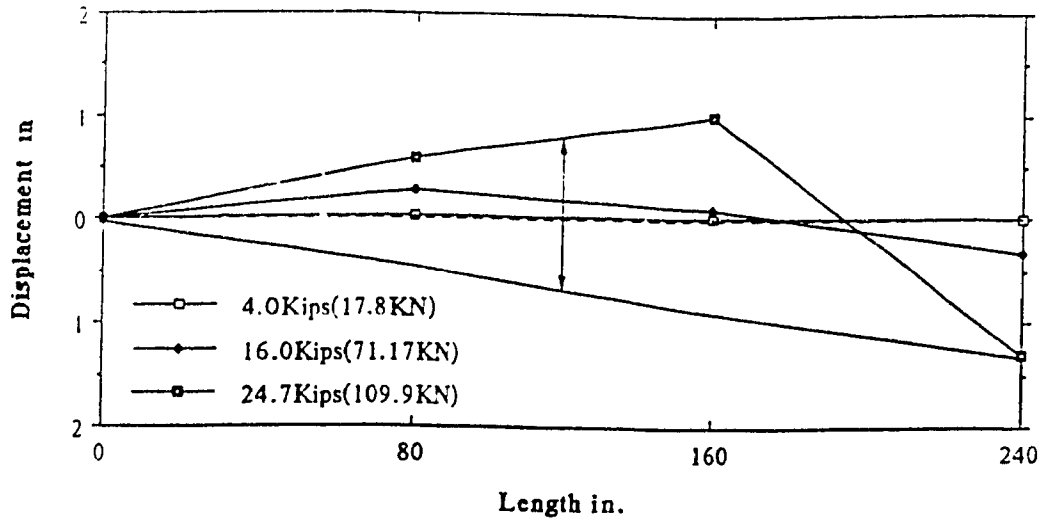


FIG. 6.5. Displacement (deformation) measured at test of straight pipe, concentric tendon position with diaphragm  $\phi = 1.9$  in.  
 Measured deflection  $y = 1.37$  in.  
 Calculated deflection  $y = 0.84$  in.

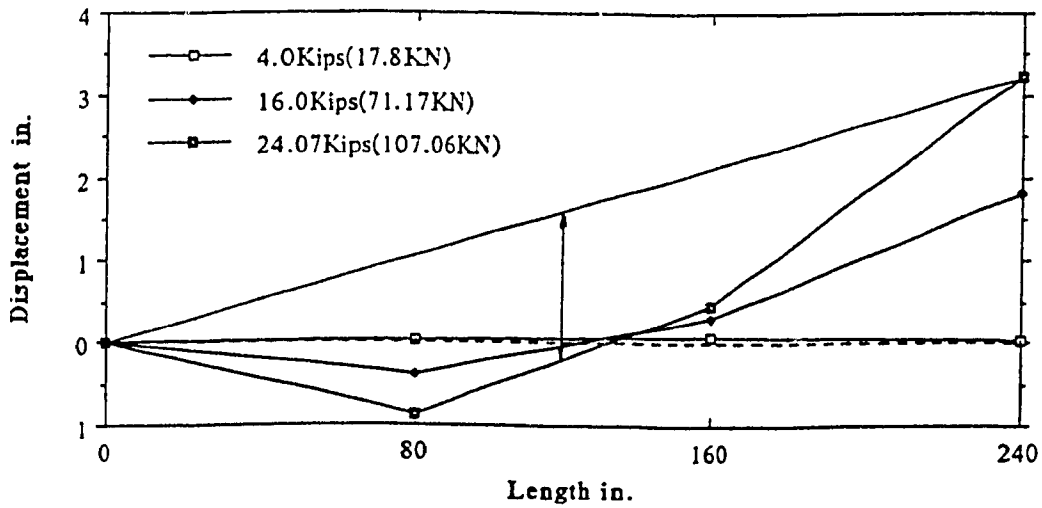


FIG. 6.6. Displacement (deformation) measured at test of curved pipe, concentric tendon position with diaphragm  $\phi = 1.9$  in.  
 Measured deflection  $y = 1.7$  in.  
 Calculated deflection  $y = 0.81$  in.

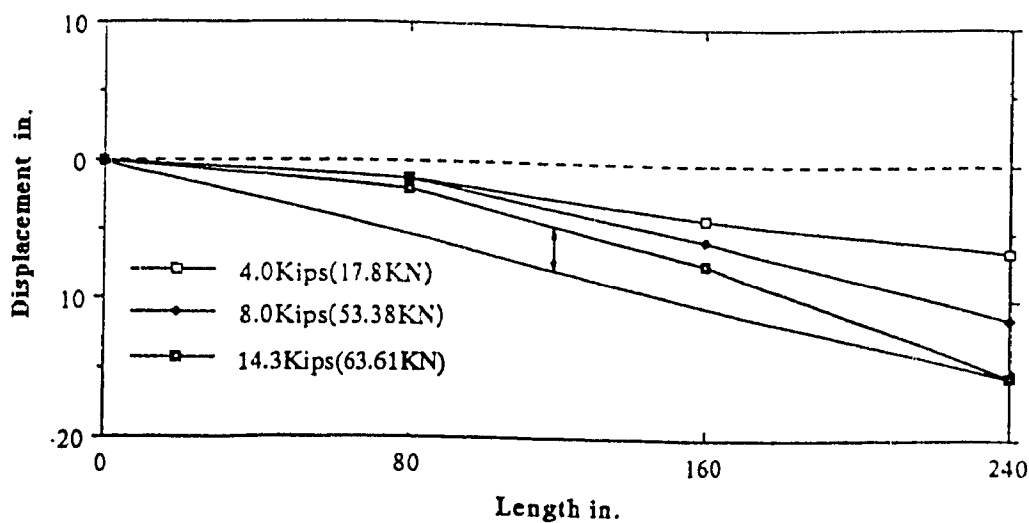


FIG. 6.7. Displacement (deformation) measured at test of straight pipe, concentric tendon position without diaphragm  $\phi = 1.9$  in.

Measured deflection  $y = 3.2$  in.

Calculated deflection  $y = 7.07$  in.

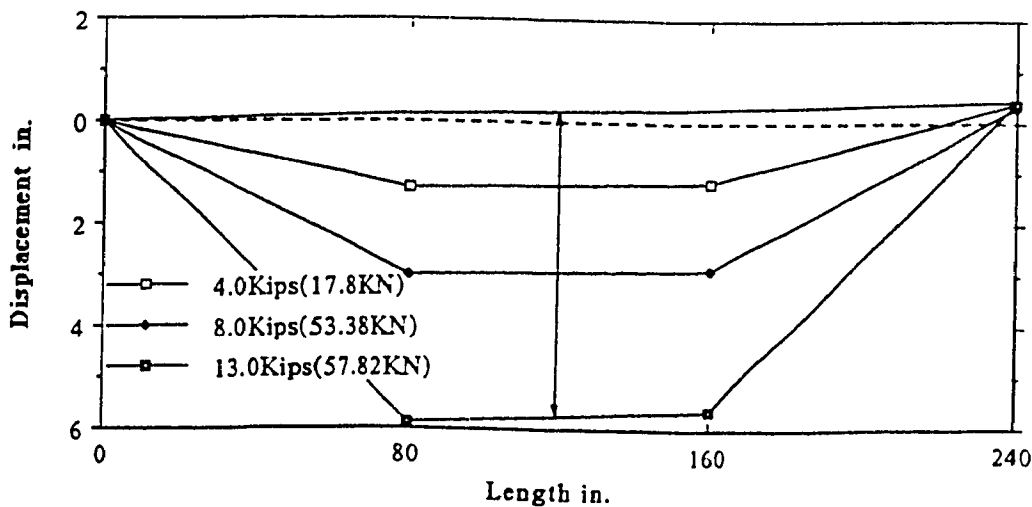


FIG. 6.8. Displacement (deformation) measured at test of straight pipe, maximum eccentric tendon position without diaphragm  $\phi = 1.9$  in.

Measured deflection  $y = 6.0$  in.

Calculated deflection  $y = 6.43$  in.

### 6.3 - MEASURED RELAXATION IN ORDINARY STEEL BARS

After stressing the bars under constant load the initial elongation were measured in early stage of loading, than after the elongation of the bars continued to increase. FIG. 6.9 shows the elongation due to relaxation in bar under constant load for 14 days period in the percentages compared to initial elongation.

The measured elongation due to relaxation for 14 days is around 3% of initial elongation's. The most part of relaxation occurred during first 3 days and was negligible after 14 days.

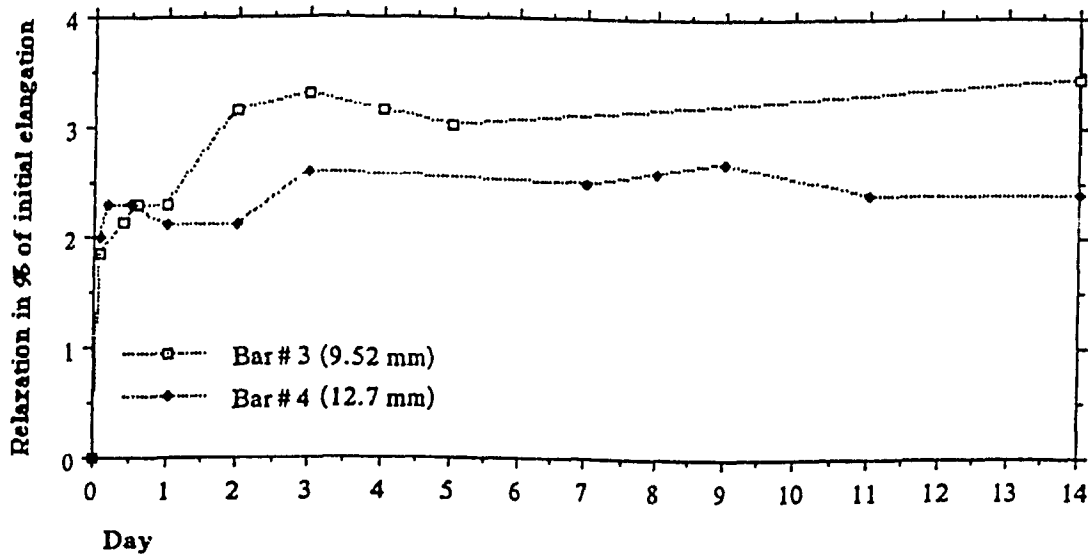


FIG. 6.9. Relaxation in percentages of initial elongation from regular reinforcing bar # 3 and # 4

# **CHAPTER 7**

## **SUMMERY AND CONCLUSIONS**

### **7.1 - SUMMERY**

The present study deals with the behavior of prestressed pipe and the effects of using diaphragms in a slender member.

The eccentricity in different tendon configuration, its effects on stress distribution in the pipe cross section, measured and calculated deflection due to eccentricity are given in the tables 6.1 and 6.2.

Tests show how important is to control the eccentricity in order to be able to raise prestressing value, and in this way to reduce the cross section area of the tension member.

Finally the study gives a bright view about prestressed - tension and prestretched - compression member and using tubes to design a long tension member, the relaxation in ordinary steel and its passable effects on prestressed member combined from ordinary and high - strength steel was also measured.

### **7.2 - CONCLUSIONS**

The test results confirm that steel pipe stressed with internally placed tendon is not subject of buckling. The deflection of pipe occurs only due to eccentricity of tendon (the gap between tendon and diaphragm).

Straight and curved pipe have the same behaviour under prestressing force and deflection from original shape (Figures 6.1 to 6.8 and also Tables 6.1 and 6.2 ). The tests show that under increasing force, pipes fail when maximum stresses are between 84% to 94% of yield strength, what could be recognized as capacity reduction factor.

The failure load  $P$  is related to eccentricity in tendon and stress distribution in pipe cross-section (see calculated deflection due to moment compared with measured). The measured deflections are close to calculated, which also proves that the deflection is not due to buckling.

The measured relaxation of normal steel under constant load as it can be seen in FIG. 20, is in order of 3% of initial elongation. The most part of relaxation occurs in early hours and has no major effect on the prestressed pipe.

It should be noted however that relaxation test was performed under tension force and only on steel rods but not on pipe. The prestressed steel structure as described can be used in many practical application and should be studied in more detail.

**REFERENCES**

- 1 American Society for Testing and Materials. (1978). "Stress-Relaxation Tests for Materials" pp. 465 - 489.
- 2 Billig, K., " Pretensioned Concrete" Part 1, civ. Eng. and P.W Rev., 1951, 46, 536 (Feb).
- 3 Drewnowski, S. (1978). "Betonowe Konstrukcje Mostowe Sprezono-Rozprezone "Prestretched - prestressed concrete bridge structures" Panstwowe Wydawnictwo Naukowe, Oddzial Warszawa - Lodz, Poland, 1 - 79 ( in Polish ).
- 4 Sprezono-Rozprezone "(Prestretched-Prestressed Concrete Bridge Structures) published by Panstwowe Wydawnictwo Naukowe, Oddzial Warszawa- Lodz, pp. 1 - 79
- 5 Dwyer, T. G. and Galambos, T. V. (1965). "Plastic Behavior of Tubular Beam Columns" Journal of Structural Division, ASCE, Vol. 91, No.ST4, pp. 153-168.  
105, No ST9, pp. 1805 - 1822.
- 6 Hathout, I. A., Temple, M. C. and Ellis, J. S. (1978). "Buckling of Space Stayed Columns" Journal of Structural Division, ASCE, Vol.
- 7 Key, P. W., Hasan, W. H. and Hancock, G. J. (1988). "Column Behavior of Cold-Formed Hollow Sections "Journal of Structural Engineering, Vol. 114, No. 2, pp. 390-407.

- 8 Knowles, R. B. and Park, R. (1970). "Axial Load Design for Concrete Filled Steel Tubes" Journal of Structural Division ASCE, Vol 96, No. ST10, pp. 2125-2153.
- 9 Koretsky, A. V. and Pritchard R. W. (1982). "Assessment of Relaxation Loss Estimates for Strands" Journal of Structural Division ASCE, Vol. 108, No. ST12, pp. 2819-2836.
- 10 Schilling, C. G. (1965) "Buckling Strength of Circular Tubes" Journal of Structural Division ASCE, Vol. 91, No. ST5, Proc. Paper 4520, pp. 325-348.
- 11 Zielinski, Z. A. (1954). "O sprezeniu konstrukcji stalowych (Prestressed Steel Structures)," Inzynieria i Budownictwo, No. 7.
- 12 Zielinski, Z. A. (1956). "Dwa przyklady zastosowania w Polsce sprezenia do wyzmocnienia istiejacych konstrukcji (Two Examples of Use of Post-Tensioning for Strengthening of Existing Structures in Poland)," Inzynieria i Budownictwo, No. 1.
- 13 Zielinski, Z.A. and Mobasher-Fard, H. (1992) "Strength and Behavior of Slender Steel Pipe Under Prestressing Force" Journal of Structural Division, vol. 118, NO. 10, pp. 2911 - 2926.



## Appendix I

### A - Calculation of stress distribution and deflection for pipes

$\phi = 1.315$  in. used in table 6.1.

#### 1 - Concentric tendon position in straight pipe with diaphragms.

**elastic stress calculation:**

$$f_{1,2} = \frac{P}{A} \pm \frac{P e}{S}$$

$$f_{1,2} = \frac{15}{0.382} \pm \frac{15 \times 0.0375}{0.108}$$

$$f_{\max} = 44.48 \text{ Ksi}$$

$$f_{\min} = 34.06 \text{ Ksi}$$

$$\frac{f_{\max}}{f_y} = \frac{44.48}{50} = 0.89$$

**plastic stress calculation:**

$$f_{1,2} = \frac{P}{A} \pm \frac{P e}{Z}$$

$$f_{1,2} = \frac{15}{0.382} \pm \frac{15 \times 0.0375}{0.148}$$

$$f_{\max} = 43.07 \text{ Ksi}$$

$$f_{\min} = 35.47 \text{ Ksi}$$

$$\frac{f_{\max}}{f_y} = \frac{43.07}{50} = 0.86$$

**moment due to eccentricity in cable:**

$$M = P \cdot e$$

$$M = 15 \times 0.0375 = 0.5625 \text{ Kips} \cdot \text{in.}$$

**deflection due to moment:**

$$y = \frac{5 M L^2}{48 E I}$$

$$y = \frac{5 \times 0.5625 \times 240^2}{48 \times 29000 \times 0.071}$$

$$y = 1.64 \text{ in.}$$

## 2 - Concentric tendon position in curved pipe with diaphragms.

**elastic stress calculation:**

$$f_{1,2} = \frac{P}{A} \pm \frac{P e}{S}$$

$$f_{1,2} = \frac{14.6}{0.382} \pm \frac{14.6 \times 0.0375}{0.108}$$

$$f_{\max} = 43.29 \text{ Ksi}$$

$$f_{\min} = 33.15 \text{ Ksi}$$

$$\frac{f_{\max}}{f_y} = \frac{43.29}{50} = 0.87$$

**plastic stress calculation:**

$$f_{1,2} = \frac{P}{A} \pm \frac{P \cdot e}{Z}$$

$$f_{1,2} = \frac{14.6}{0.382} \pm \frac{14.6 \times 0.0375}{0.148}$$

$$f_{\max} = 41.89 \text{ Ks}$$

$$f_{\min} = 34.55 \text{ Ksi}$$

$$\frac{f_{\max}}{f_y} = \frac{41.89}{50} = 0.84$$

**moment due to eccentricity in cable:**

$$M = P \cdot e$$

$$M = 14.6 \times 0.0375 = 0.55 \text{ Kips} \cdot \text{in.}$$

**deflection due to moment:**

$$y = \frac{5 M L^2}{48 E I}$$

$$y = \frac{5 \times 0.55 \times 240^2}{48 \times 29000} = 0.071$$

$$y = 1.6 \text{ in.}$$

### 3 - Concentric tendon position in straight pipe without diaphragms.

As soon as the pipe is under pressure the eccentricity becomes maximum.

**elastic stress calculation:**

$$f_{1,2} = \frac{P}{A} \pm \frac{P e}{S}$$

$$f_{1,2} = \frac{9.9}{0.382} \pm \frac{9.9 \times 0.2575}{0.108}$$

$$f_{\max} = 49.52 \text{ Ksi}$$

$$f_{\min} = 2.31 \text{ Ksi}$$

$$\frac{f_{\max}}{f_y} = \frac{49.52}{50} = 0.99$$

**plastic stress calculation:**

$$f_{1,2} = \frac{P}{A} \pm \frac{P e}{Z}$$

$$f_{1,2} = \frac{9.9}{0.382} \pm \frac{9.9 \times 0.2575}{0.148}$$

$$f_{\max} = 43.14 \text{ Ksi}$$

$$f_{\min} = 8.7 \text{ Ksi}$$

$$\frac{f_{\max}}{f_y} = \frac{43.14}{50} = 0.86$$

**moment due to eccentricity in cable:**

$$M = P \cdot e$$

$$M = 9.9 \times 0.2575 = 2.55 \text{ Kips} \cdot \text{in}$$

**deflection due to moment:**

$$y = \frac{5 M L^2}{48 E I}$$

$$y = \frac{5 \times 2.55 \times 240^2}{48 \times 29000 \times 0.071}$$

$$y = 7.43 \text{ in.}$$

**4 - Maximum eccentric tendon position in straight pipe without diaphragms.**

**elastic stress calculation:**

$$f_{1,2} = \frac{P}{A} \pm \frac{P e}{S}$$

$$f_{1,2} = \frac{11}{0.382} \pm \frac{11 \times 0.2575}{0.108}$$

$$f_{\max} = 55.02 \text{ Ksi}$$

$$f_{\min} = 2.56 \text{ Ksi}$$

$$\frac{f_{\max}}{f_y} = \frac{55.02}{50} = 1.1$$

**plastic stress calculation:**

$$f_{1,2} = \frac{P}{A} \pm \frac{P \cdot e}{Z}$$

$$f_{1,2} = \frac{11}{0.382} \pm \frac{11 \times 0.2575}{0.148}$$

$$f_{\max} = 47.93 \text{ KSI}$$

$$f_{\min} = 9.65 \text{ KSI}$$

$$\frac{f_{\max}}{f_y} = \frac{47.93}{50} = 0.96$$

**moment due to eccentricity in cable:**

$$M = P \cdot e$$

$$M = 11 \times 0.2575 = 2.83 \text{ Kips} \cdot \text{in.}$$

**deflection due to moment:**

$$y = \frac{5 M L^2}{48 E I}$$

$$y = \frac{5 \times 2.83 \times 240^2}{48 \times 29000 \times 0.071}$$

$$y = 8.25 \text{ in.}$$

## B - Calculation of stress distribution and deflection for pipes

$\phi = 1.9$  in. .used in table 6.2.

### 1 - Concentric tendon position in straight pipe with diaphragms.

**elastic stress calculation:**

$$f_{1,2} = \frac{P}{A} \pm \frac{P e}{S}$$

$$f_{1,2} = \frac{25}{0.566} \pm \frac{25 \times 0.0375}{0.242}$$

$$f_{\max} = 48.04 \text{ Ksi}$$

$$f_{\min} = 40.3 \text{ Ksi}$$

$$\frac{f_{\max}}{f_y} = \frac{48.04}{51} = 0.94$$

**plastic stress calculation:**

$$f_{1,2} = \frac{P}{A} \pm \frac{P e}{Z}$$

$$f_{1,2} = \frac{25}{0.566} \pm \frac{25 \times 0.0375}{0.325}$$

$$f_{\max} = 47.05 \text{ Ks}$$

$$f_{\min} = 41.29 \text{ Ksi}$$

$$\frac{f_{\max}}{f_y} = \frac{47.05}{51} = 0.92$$

**moment due to eccentricity in cable:**

$$M = P \cdot c$$

$$M = 25 \times 0.0375 = 0.9375 \text{ Kips} \cdot \text{in.}$$

**deflection due to moment:**

$$y = \frac{5 M L^2}{48 E I}$$

$$y = \frac{5 \times 0.9375 \times 240^2}{48 \times 29000 \times 0.23}$$

$$y = 0.84 \text{ in.}$$

## 2 - Concentric tendon position in curved pipe with diaphragms.

**elastic stress calculation:**

$$f_{1,2} = \frac{P}{A} \pm \frac{P e}{S}$$

$$f_{1,2} = \frac{24.07}{0.566} \pm \frac{24.07 \times 0.0375}{0.242}$$

$$f_{\max} = 46.26 \text{ Ksi}$$

$$f_{\min} = 38.8 \text{ Ksi}$$

$$\frac{f_{\max}}{f_y} = \frac{46.26}{51} = 0.91$$



**plastic stress calculation:**

$$f_{1,2} = \frac{P}{A} \pm \frac{P e}{Z}$$

$$f_{1,2} = \frac{24,07}{0.566} \pm \frac{24.07 \times 0.0375}{0.325}$$

$$f_{\max} = 45.31 \text{ Ks}$$

$$f_{\min} = 39.75 \text{ Ksi}$$

$$\frac{f_{\max}}{f_y} = \frac{45.31}{51} = 0.89$$

**moment due to eccentricity in cable:**

$$M = P.e$$

$$M = 24.07 \times 0.0375 = 0.9 \text{ Kips} \cdot \text{in}$$

**deflection due to moment:**

$$y = \frac{5 M L^2}{48 E I}$$

$$y = \frac{5 \times 0.9 \times 240^2}{48 \times 29000 \times 0.23}$$

$$y = 0.81 \text{ in.}$$

### **3 - Concentric tendon position in straight pipe without diaphragms.**

**As soon as the pipe is under pressure the eccentricity becomes maximum.**

**elastic stress calculation:**

$$f_{1,2} = \frac{P}{A} \pm \frac{Pc}{S}$$

$$f_{1,2} = \frac{14.3}{0.566} \pm \frac{14.3 \times 0.55}{0.242}$$

$$f_{\max} = 57.76 \text{ Ksi}$$

$$f_{\min} = -7.24 \text{ Ksi}$$

$$\frac{f_{\max}}{f_y} = \frac{57.76}{51} = 1.1$$

**plastic stress calculation:**

$$f_{1,2} = \frac{P}{A} \pm \frac{Pc}{Z}$$

$$f_{1,2} = \frac{14.3}{0.566} \pm \frac{14.3 \times 0.55}{0.325}$$

$$f_{\max} = 49.46 \text{ Ksi}$$

$$f_{\min} = 1.06 \text{ Ksi}$$

$$\frac{f_{\max}}{f_y} = \frac{49.46}{51} = 0.97$$

**moment due to eccentricity in cable:**

$$M = P \cdot c$$

$$M = 14.3 \times 0.55 = 7.86 \text{ Kips} \cdot \text{in.}$$

**deflection due to moment:**

$$y = \frac{5 M L^2}{48 E I}$$

$$y = \frac{5 \times 7.86 \times 240^2}{48 \times 29000 \times 0.23}$$

$$y = 7.07 \text{ in.}$$

**4 - Maximum eccentric tendon position in straight pipe without diaphragms.**

**elastic stress calculation:**

$$f_{1,2} = \frac{P}{A} \pm \frac{P e}{S}$$

$$f_{1,2} = \frac{13}{0.566} \pm \frac{13 \times 0.55}{0.242}$$

$$f_{\max} = 52.5 \text{ Ksi}$$

$$f_{\min} = - 6.56 \text{ Ksi}$$

$$\frac{f_{\max}}{f_y} = \frac{52.5}{51} = 1.03$$

**plastic stress calculation:**

$$f_{1,2} = \frac{P}{A} \pm \frac{P e}{Z}$$

$$f_{1,2} = \frac{13}{0.566} \pm \frac{13 \times 0.55}{0.325}$$

$$f_{\max} = 44.97 \text{ Ks}$$

$$f_{\min} = 0.97 \text{ Ksi}$$

$$\frac{f_{\max}}{f_y} = \frac{44.97}{51} = 0.88$$

**moment due to eccentricity in cable:**

$$M = P \cdot e$$

$$M = 13 \times 0.55 = 7.15 \text{ Kips} \cdot \text{in.}$$

**deflection due to moment:**

$$y = \frac{5 M L^2}{48 E I}$$

$$y = \frac{5 \times 7.15 \times 240^2}{48 \times 29000 \times 0.23}$$

$$y = 6.43 \text{ in.}$$