

INTRODUCTION TO THE USE OF DIGITAL COMPUTERS
IN AN ELECTRIC POWER SYSTEM
DISPATCHING CENTER

Tu-Anh Quan

A MAJOR TECHNICAL REPORT
IN THE
FACULTY OF ENGINEERING

Presented in partial fulfilment of the requirements for the

Degree of MASTER OF ENGINEERING

at

Sir George Williams University

Montréal, Canada

March, 1973

© Tu-Anh Quan 1973

ABSTRACT

This technical report is a study of some of the most important functions performed by Dispatching Center Computers; some aspects of the equipment used in a Dispatching Center are also discussed.

A review of Main Power Systems Components is given in Chapter I. Chapter 2 deals with mathematical tools required for the development of some application programs. A description of Dispatching Center Hardware is the subject of chapter 3, which will show how data is collected from various points of the system, and describe the equipment required to transmit data to the Dispatching Center. Computers used to process and display data are also discussed in chapter 3. Chapter 4 is an introduction to Basic Dispatching Center Software, showing how data is processed by the computer and dealing with the importance of the operating systems in real-time applications. A general description of the Power System Application Programs is presented in chapter 5, followed by a detailed study of each application program in chapters 6 to 12. Chapter 6 is concerned with Load Flow; Chapter 7 with State Estimator; Chapter 8 with Economic Dispatch; Chapter 9 with Scheduling (Unit Commitment) Programs; Chapter 10 with Watt Frequency Control (LFC) and Var Voltage Control; Chapter 11 with Power System Stability and Chapter 12 with Contingency Analysis.

TABLE OF CONTENTS

	Page
ABSTRACT	i
LIST OF FIGURES	yii
ACKNOWLEDGEMENTS	xii
INTRODUCTION	xiii
Chap.1- MAIN POWER SYSTEM COMPONENTS.....	1
1.1 Electric Power System Configuration	1
1.2 Generating Stations.....	1
1.2.1 Hydraulic Station.....	1
1.2.2 Nuclear Power Station	4
1.2.3 Steam(or Thermal) Station	4
1.3 Transformer Stations	7
1.3.1 Transformers	7
1.3.2 Busbars.....	7
1.3.3 Circuit Breakers.....	7
1.3.4 Transmission Line.....	7
1.3.5 Synchronous Compensator	7
1.3.6 Shunt Capacitors and Reactors.....	7
1.3.7 Series Capacitors	8
1.4 A.C.Generators	8
1.4.1 Round Rotor Generator.....	8
1.4.2 Salient Rotor Generator.....	8
1.4.3 Machine Equations.....	10
1.4.4 Output Power of Generator	12

	Page
1.5 Power Transformer.....	13
1.5.1 Two-winding Transformers.....	13
1.5.2 Three-winding Transformer.....	18
1.5.3 Auto Transformer.....	18
1.5.4 Load Tap Changing Transformer.....	19
1.6 Representation of Power Lines.....	19
Chap.2- SELECTED NETWORK CONCEPTS AND NETWORK EQUATIONS.....	28
2.1 Instantaneous Power.....	28
2.2 Complex Power.....	30
2.3 Calculation of sending and received Voltages in terms of Power and Reactive Power.....	31
2.4 The Power Transfer Equation of a Generator.....	33
2.5 Summary of some Main Network Equations in Matrix form.....	34
2.5.1 Introduction.....	34
2.5.2 Summarized technique to find impedances and admittances.....	36
2.5.3 Application.....	37
Chap.3- BASIC DISPATCHING CENTER HARDWARE.....	42
3.1 Introduction.....	42
3.2 Data Acquisition and Supervisory Control or DASC systems.....	44
3.2.1 Introduction.....	44
3.2.2 DASC Equipment at Remote Stations.....	44
3.2.3 DASC Equipment at the Master Station.....	51
3.3 Computer Configuration Analysis.....	51
3.3.1 Multicomputer System.....	51
3.3.2 Multiprocessor System.....	51

	Page
3.3.3 Comparison between Multicomputer and Multiprocessor.....	54
3.3.4 Standard Processor Peripherals.....	54
3.4 Information Display and Operator Control Console.....	57
3.4.1 Introduction.....	57
3.4.2 Group Display.....	58
3.4.3 CRT Displays.....	59
3.4.4 Digital Display.....	59
3.4.5 Operator Console Equipment.....	59
Chap.4- BASIC DISPATCHING COMPUTER SOFTWARE CONCEPTS.....	63
4.1 Operating Systems.....	63
4.2 Batch Processing.....	63
4.3 Real-Time Processing.....	63
4.4 Multicomputer and Multiprocessor.....	64
4.5 Multiprogramming and Time-Sharing.....	64
4.6 Languages.....	64
4.7 Off-Line and On-Line Diagnostics Program.....	65
4.8 Utilities Programs and Library.....	65
4.9 Real-Time Computation.....	65
4.9.1 Foreground and Background.....	65
4.9.2 The Real-Time Control Software.....	66
Chap.5- POWER SYSTEM APPLICATION PROGRAMS USED IN A DISPATCHING CENTER.....	68
5.1 Power System Problems.....	68
5.2 Power System Problems Classification.....	68
5.3 General Description of Power System Application Programs....	68
Chap.6- LOAD FLOW.....	75
6.1 Introduction.....	75

	Page
6.2 Bus Classification.....	76
6.3 Load Flow Equation Classification.....	76
6.4 Loading Equations for Slack Buses.....	78
6.5 Line Flow Equations.....	79
Chap.7- STATE ESTIMATION PROGRAM.....	81
7.1 Introduction.....	81
7.2 State Estimator Design.....	83
7.3 Power System State Estimator:Inputs and Outputs.....	83
7.4 Elements of an Estimator.....	84
7.5 Explanation of the Estimator Blocks.....	84
7.6 Applications of the State Estimator.....	87
Chap.8- ECONOMIC DISPATCH.....	88
8.1 Introduction.....	88
8.2 Optimum Generator Allocation with Line Losses neglected: intuitive approach.....	88
8.3 The General Economic Optimal Dispatch Problem:mathematical approach.....	90
8.4 Minimization Technique:the Lagrangian Multiplier.....	91
8.5 The Incremental Cost λ of Generators in same Plants, no Lines Losses.....	91
8.6 The Incremental cost λ of many Plants with long Lines Loss..	92
Chap.9-SCHEDULING(UNIT COMMITMENT) PROGRAMS.....	94
9.1 Introduction.....	94
9.2 Methods for Scheduling Units.....	94
9.2.1 Priority List Scheduling.....	94
9.2.2 Dynamic Programming.....	95
9.3 Scheduling Programs.....	95

	Page
Chap.10- WATT-FREQUENCY AND VAR-VOLTAGE CONTROL.....	98
10.1 Introduction.....	98
10.2 Turbine Governor Control or Power Frequency Control.....	98
10.3 Voltage Regulator Control or Var-Voltage Control.....	100
10.4 Interaction of Pf and QV Control.....	100
10.5 The Watt-Frequency Control.....	103
10.5.1 Speed Governor Model.....	103
10.5.2 Turbine Model.....	103
10.5.3 Power System Transfer Function.....	104
10.5.4 Tie-Line Transfer Function.....	104
10.5.5 The Uncontrolled Case.....	106
10.5.6 The Controlled Case.....	107
10.6 The Var-Voltage Control.....	107
Chap.11- POWER SYSTEM STABILITY.....	111
11.1 Classification of Power System Transients.....	111
11.2 Behaviour of the Synchronous Machine during a balanced Short-Circuit.....	112
11.3 Determination of Power Angle δ by using the Swing Equation.....	114
11.4 Stability Problems Solutions.....	116
Chap.12- CONTINGENCY ANALYSIS.....	117
12.1 Objectives of Contingency Analysis in Power System.....	117
12.2 Steady-State Contingency Evaluation Program.....	118
12.3 Methods of Contingency Analysis.....	118
CONCLUSIONS.....	122
REFERENCES & BIBLIOGRAPHY.....	123

LIST OF FIGURES

	Page
Fig. 1.1 Schematic diagram of an electric System.....	2
Fig. 1.2 Schematic diagram of a Hydrcelectric generating station.....	3
Fig. 1.3 Schematic diagram of a nuclear power generating station.....	5
Fig. 1.4 Schematic diagram of a steam generating station.....	6
Fig. 1.5 Elementary 2-pole cylindrical-rotor field winding.....	9
Fig. 1.6 Salient poles synchronous machine.....	9
Fig. 1.7 Simplified representation of a synchronous machine and its phasor diagram.....	11
Fig. 1.8 Representation of an A.C. machine with saliency effect.....	11
Fig. 1.9 Representation of a two-winding transformer, with impedances referred to the primary side.....	14
Fig. 1.10 Approximate representation of a 2-winding transformer....	14
Fig. 1.11 Simplified representation of a 2-winding transformer.....	16
Fig. 1.12a Three-winding transformer diagram.....	16
Fig. 1.12b Alternate representation of a 3-winding transformer.....	16

Fig. 1.13	Model of a three-winding transformer.....	17
Fig. 1.14	Auto-transformer representation.....	17
Fig. 1.15	Equivalent circuit of an auto-transformer.....	17
Fig. 1.16	A tap changing transformer representation.....	20
Fig. 1.17	Actual power line representation.....	20
Fig. 1.18	Short line representation.....	21
Fig. 1.19	Medium line representation.....	21
Fig. 1.20	Long line representation.....	23
Fig. 1.21	π Equivalent circuit of a long line.....	23
Fig. 1.22	T equivalent circuit of a long line.....	26
Fig. 1.23	Detailed representation of a long line.....	26
Fig. 2.1	A simple circuit.....	29
Fig. 2.2	The phasor diagram of the circuit shown in fig.2.1.....	29
Fig. 2.3	Complex Representation of Circuit of Fig.2.1.....	29
Fig. 2.4	Power Triangle Representation.....	29
Fig. 2.5	Representation of a simple link.....	32
Fig. 2.6	Phasor Diagram of a simple link.....	32
Fig. 2.7	A generator representation(a),and its phasor diagram(b)..	32
Fig. 2.8	Representation of an A.C. Generator Rotor.....	35

	Page
Fig. 2.9	A simple Network.....35
Fig. 2.10	Circuit of fig. 2.9 redrawn.....39
Fig. 3.1	General Equipment of a Dispatching Center.....43
Fig. 3.2	Schematic Function of the DASC Equipment installed at a Remote Station.....45
Fig. 3.3	Data Gathering Functions and Control Functions at a Remote Station of DASC System.....47
Fig. 3.4	Arrangement of Remote Stations and the Master Station..50
Fig. 3.5	Equipment of the Master Station in the DASC System.....52
Fig. 3.6	Multicomputer Block Diagram.....53
Fig. 3.7	Multiprocessor Block Diagram.....55
Fig. 3.8	General Equipment Layout in a Dispatching Center.....60
Fig. 3.9	Block Diagram of Data Flow and Equipment Layout in a Dispatching Center.....61
Fig. 3.10	Operator Console.....62
Fig. 4.1	Real-Time Supervisor Functional Flow.....67
Fig. 5.1	Data Processing of Power System.....69
Fig. 5.2	Classification of Power System Problems vs Time.....70

	Page
Fig. 5.3	General Flowchart of Power System Operation Software....71
Fig. 5.4	Relation between Power System Application Programs and Mathematical Theory.....72
Fig. 6.1	Representation of various node types.....77
Fig. 6.2	General Arrangement of a Load Flow Program.....80
Fig. 7.1	Estimator Inputs and Outputs.....82
Fig. 7.2	On-line State Estimator Block Diagram.....86
Fig. 8.1	Input-Output Generator Curve with Ordinate converted to \$/hr.....89
Fig. 8.2	Incremental cost curve for a Generator.....89
Fig. 8.3	Economic Distribution of Load between 4 Generators.....89
Fig. 9.1	Functional Diagram of Scheduling Program.....97
Fig. 10.1	Power Production in function of frequency.....99
Fig. 10.2	Circuit of a Generator.....99
Fig. 10.3	Var Production vs Generator Terminal Voltage.....99
Fig. 10.4	Relationship between Pf and QV loops.....101
Fig. 10.5	Transfer Functions of LFC loops.....102
Fig. 10.6	Block Diagram of a Tie-Line.....102

	Page
Fig. 10.7 Complete Block Diagram Representation of a Control Area i	105
Fig. 10.8 Controlled Area i.....	105
Fig. 10.9 The Var-Voltage Control Loop.....	108
Fig. 10.10 Complete Block Diagram of the QV Control Loop.....	110
Fig. 11.1 Transient Stator Short-Circuit Current of a Synchronous Machine.....	113
Fig. 11.2 Generator Representation.....	115
Fig. 11.3 Representation of a Turbine and a Generator with the power angle δ	115
Fig. 12.1 Flowchart of Security Related Functions.....	119

ACKNOWLEDGEMENTS

The author wishes to express his gratitude to Dr. A. Antoniou for his suggestions and his whole-hearted interest throughout the preparation of this report.

Deep appreciation is also expressed to members of Automation Division of the Hydro-Quebec Engineering Department, for free use of their documentation.

INTRODUCTION

The problem of operating electrical power systems has become so complex in nature, that human decision-making procedures are not practical any more. This complexity is the result of two main trends: the expansion in size of power systems and the increased number of interconnections. With the availability of powerful techniques of power system operation analysis, the computers have begun to appear at the Control or Dispatching Centers of many electrical utilities.

These computers are quite essential in solving fast changing operation problems. Some of the many mathematical functions performed by computers are: Area Control Error, Economic Dispatch and Interchange, Hydro and Thermal Production Coordination, Load Forecasting, Load Frequency Control, Load Shedding, Maintenance Scheduling, Load Flow, Reserve Monitoring, Security Analysis, Unit Commitment, Voltage and Var Control, System Stability Analysis, etc.

The scope of this report is to study some aspects of the design of a Computer in a Dispatching Centre, including Hardware and Software characteristics, as well as the Data Acquisition Equipment. Only some of the most important applications programs concerning directly the operation of a Dispatching Center will be studied. Other Applications Software used in system planning, such as Load Forecasting, Hydro and Thermal Production, etc, are not discussed here.

CHAPTER I

MAIN POWER SYSTEM COMPONENTS

1.1 Electric Power System Configuration

An electric power system consists mainly of a number of generating stations, transformer stations, transmission lines, step down voltage transformer stations and loads. Fig.1.1 shows a general view of an electric system.

1.2 Generating Stations

There are 3 main types of generating station: hydraulic, nuclear and steam or thermal stations.

1.2.1 Hydraulic Station

Fig. 1.2 shows a schematic diagram of a hydraulic station. The reservoir (a) supplies the potential energy to drive the turbine and is also used as a water reserve for seasonal variations in water level. The canal (c) and the pentock (d) bring water to the turbine. The surge tank (b) acts as security against a sudden stop of water into the turbine. The turbine (e) transforms hydraulic energy into mechanical one which drives the generator (f) to generate electricity. To maintain a desired speed of turbine, a speed regulator (h) is used to control the water supply to the turbine. The voltage regulator (i) monitors an exciter (g) which in turn acts upon the rotor to

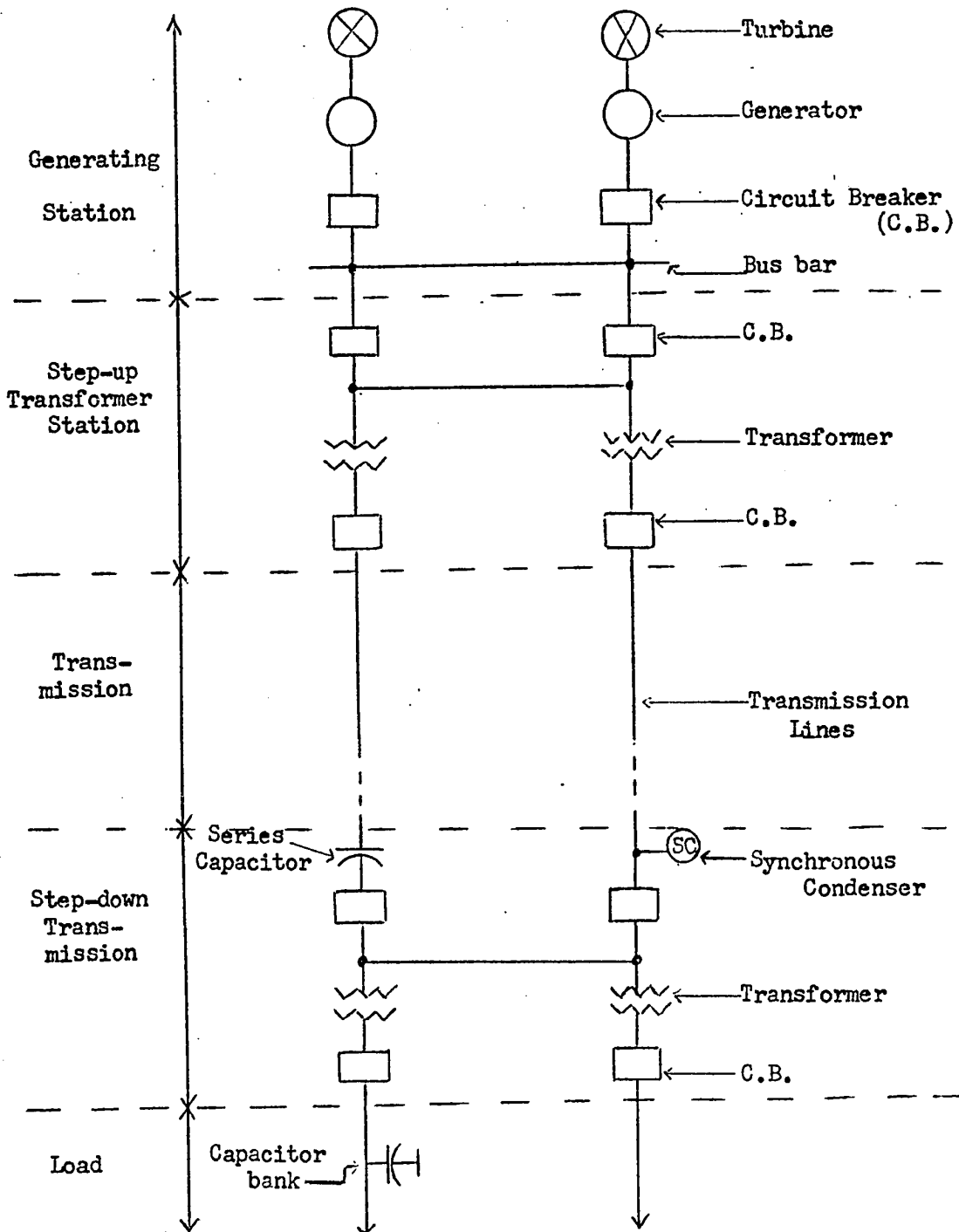
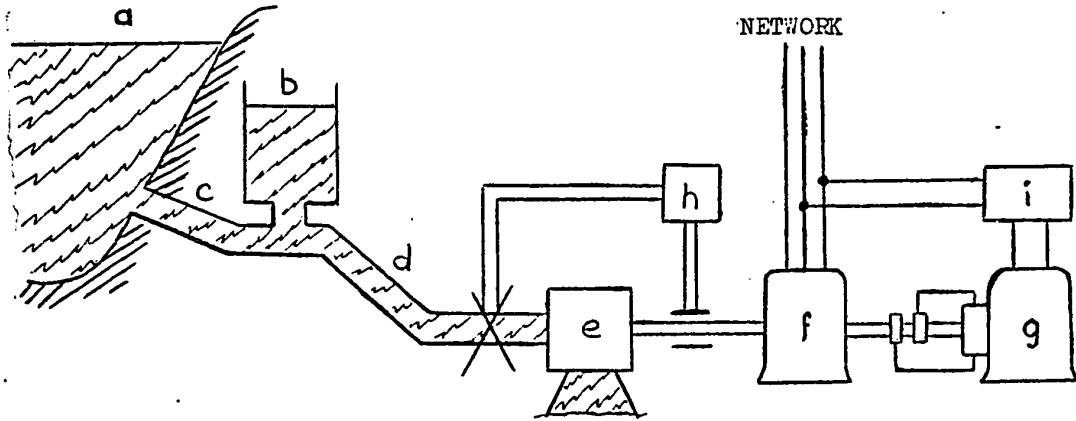

Fig. 1.1 Schematic Diagram of an Electric System.



- | | | | |
|----|------------|----|-------------------|
| a: | reservoir | e: | turbine |
| b: | surge tank | f: | generator |
| c: | canal | g: | exciter |
| d: | penstock | h: | speed regulator |
| | | i: | voltage regulator |

Fig. 1.2 Schematic diagram of a hydroelectric generating station

maintain the voltage at the desired level.

1.2.2 Nuclear power station

As shown in fig. 1.3, a main component of a nuclear station is the reactor (a). Many types of reactor can be found in the market, but all function by the same principle: absorption by neutrons of kinematic energy and transformation of this energy by means of a liquid or gas. Again, this energy is transmitted into water (or steam) in an exchanger (b). After driving the turbine (e), steam is changing its state in the condenser (c). All control equipments perform the same function as in the hydraulic station.

1.2.3 Steam (or thermal) station

When hydraulic reserves are neither available nor economical, steam stations are preferred. Fig. 1.4 shows a typical arrangement of a steam generating station. A boiler (b) is heated by a fuel (oil, gas or coal). The water in the boiler is transformed, under pressure, into steam which supplies 2 turbines, a high pressure turbine (g) and a low pressure turbine (h). The water then returns to the condenser (c), and circulates in the reheater (f) to improve the heat cycle efficiency.

Control equipment such as voltage regulator or speed regulator are already described in the hydraulic station.

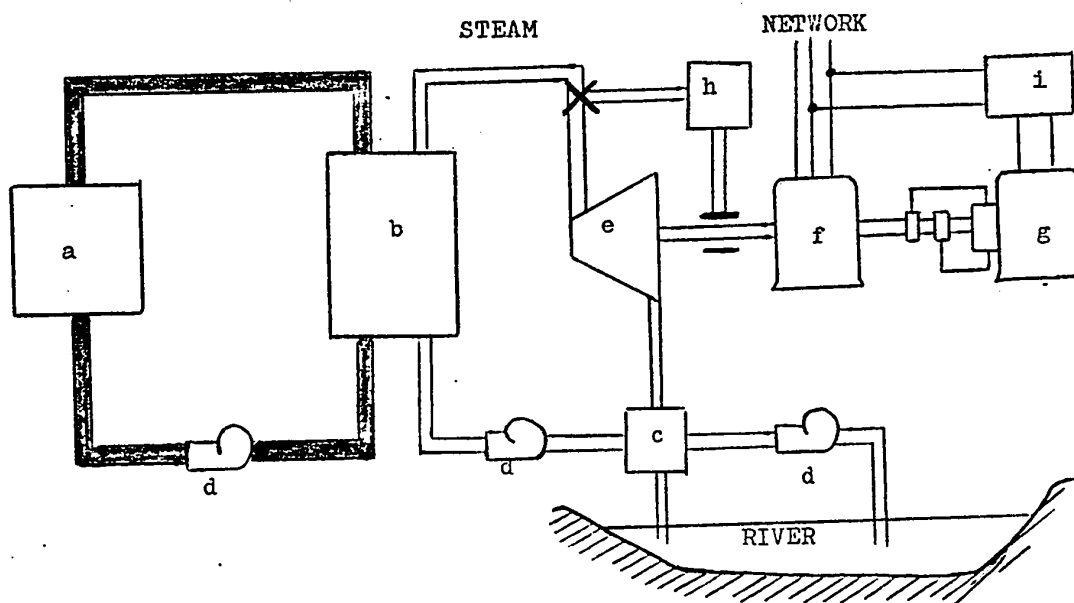

a : reactor
 b : heat exchanger
 c : condenser
 d : pumps

e : turbine
 f : generator
 g : exciter
 h : speed regulator
 i : voltage regulator

Fig. 1.3 Schematic diagram of a nuclear power generating station

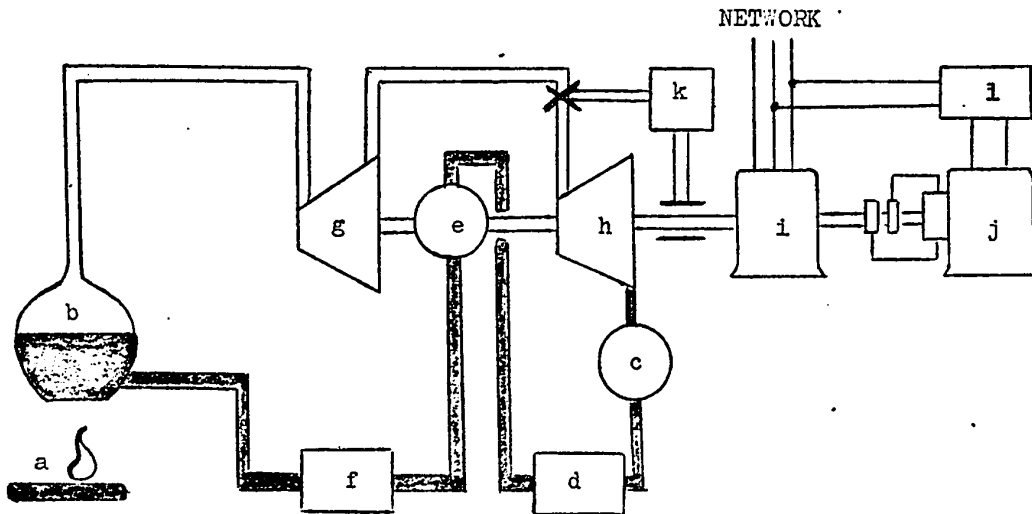

- | | | | |
|-----|------------------------|-----|-----------------------|
| a : | fuel | g : | high pressure turbine |
| b : | boiler | h : | low pressure turbine |
| c : | condenser | i : | generator |
| d : | low pressure reheater | j : | exciter |
| e : | pump | k : | speed regulator |
| f : | high pressure reheater | l : | voltage regulator |

Fig. 1.4 Schematic diagram of a steam generating station

1.3 Transformer Stations

These consist mainly of transformers, busbars, circuit breakers, transmission lines, and some voltage control equipment such as: synchronous compensators, reactors and capacitors.

1.3.1 Transformers are used to step-up voltage to high level required to transmit power. The choice of transmission voltage is usually dictated by the voltage already in use in the general vicinity. In this way direct connections to neighbouring systems can be made.

1.3.2 Busbars : even with careful design, some breakdowns often happen and some generators may have to be taken out of service. The busbar arrangement in substation help to direct power flow to healthy equipment; thus an uninterrupted service can be maintained.

1.3.3 Circuit breakers : these are devices for interrupting a circuit under normal or abnormal conditions. Ordinarily, they are required to function infrequently. In normal conditions, they close or open circuits, and in abnormal conditions, they operate to cut off the fault, hence preventing damages to neighbouring equipment.

1.3.4 Transmission lines are used to convey power.

1.3.5 Synchronous compensator : is a synchronous motor running without mechanical load. Depending on the value of excitation, it can absorb or generate reactive power. It is used to control voltage and power factor.

1.3.6 Shunt Capacitors and Reactors. Shunt capacitors are used for lagging power-factor circuits, whereas reactors are used on those with leading power-factor such as created by lightly loaded cables. In both cases, the effect is to supply the required reactive power to maintain the desired voltage level.

1.3.7 Series Capacitors are connected in series with the power line and used to reduce the inductive reactance between the supply point and the load.

1.4 A.C. Generator

An A.C. Generator, or synchronous machine, is one in which A.C. current is obtained from the armature winding when direct current is impressed on the field winding. The armature winding, usually located on the stator, produces a rotating magnetic field. The stator field rotates at synchronous speed. Ability to produce a steady torque results from the interaction of the stator and rotor fields when the rotor is also revolving at synchronous speed. There are two types of generator: round rotor and salient rotor generators.

1.4.1 Round Rotor Generator.

In the round or cylindrical rotor shown in fig. 1.5, the field winding is situated in slots cut axially along the rotor field. This machine is suitable for operation at high speeds; hence it is known as "turbo-alternator".

1.4.2 Salient Rotor Generator.

In the salient poles rotor, the poles project as shown in fig. 1.6, and low speed operation driven by hydraulic turbines is usual.

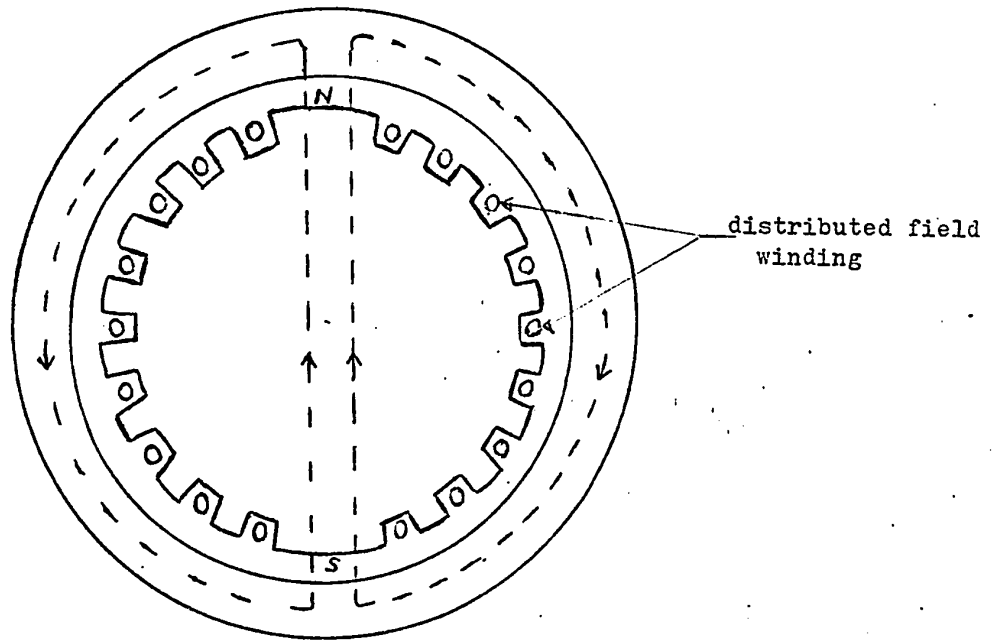

Fig. 1.5 Elementary 2-pole cylindrical-rotor field winding

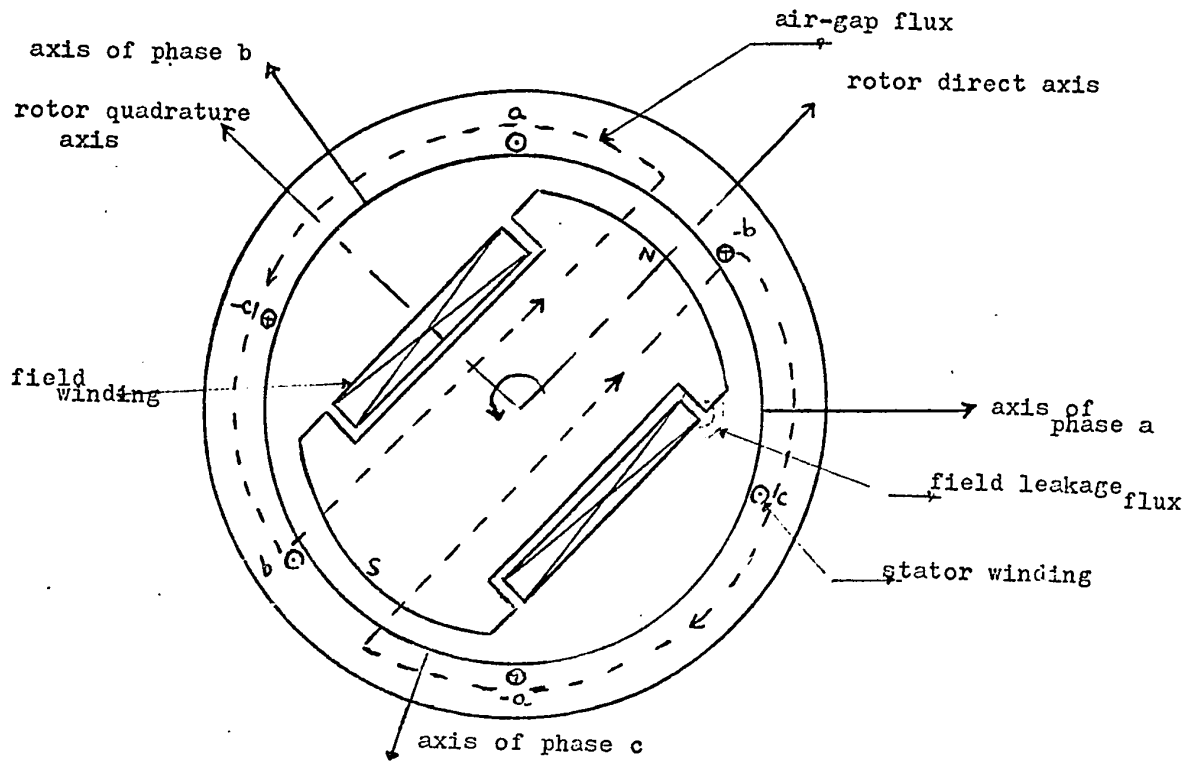

Fig. 1.6 Salient poles synchronous machine

The formula $f = \text{Number of Poles} \times \text{Speed} / 120$ explains why, for same power frequency, slow speed of hydraulic turbine needs a great number of poles, and high speed rotor of steam turbine requires a low number of poles.

1.4.3 Machine Equations (5)

The two equivalent circuits for the two types of machines mentioned above, are as follows:

1 Without the effect of saliency and assuming constant flux, a synchronous machine can be represented by the equivalent circuit of fig. 1.7a, in which the voltage source E is given by the equation:

$$E = V + r_a I + jX_s I$$

where : E = voltage back of transient reactance

V = machine terminal voltage

I = machine terminal current

r_a = armature resistance

$X_d = X_s =$ synchronous reactance = X_q in cylindrical rotor machine

The corresponding phasor diagram is shown in fig. 1.7b

2 With saliency effect : saliency and changes in field flux can be taken into account by representing the effects of the 3-phase quantities of a synchronous machine by components acting along the direct and quadrature axes, as shown in fig. 1.8.

The voltage E is given by the equation:

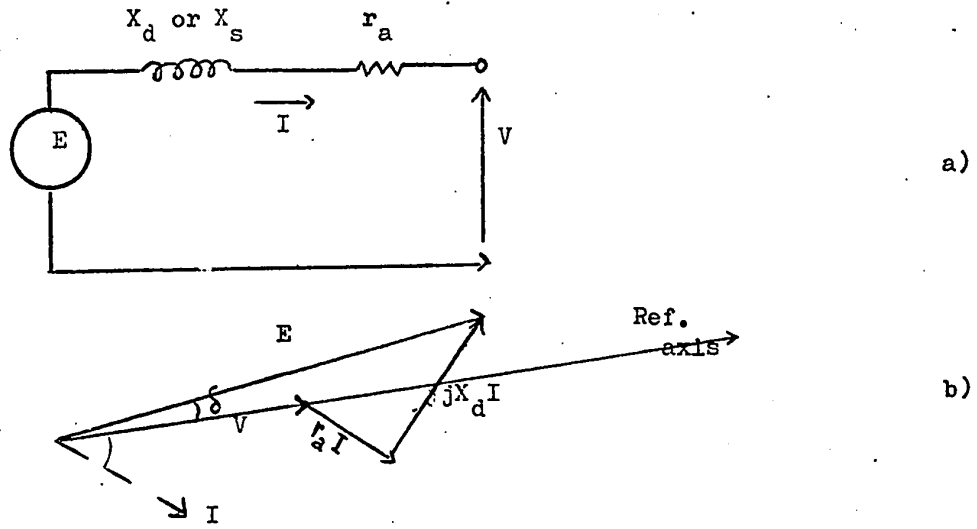

Fig. 1.7 Simplified representation of a synchronous machine (a) and its phasor diagram (b)

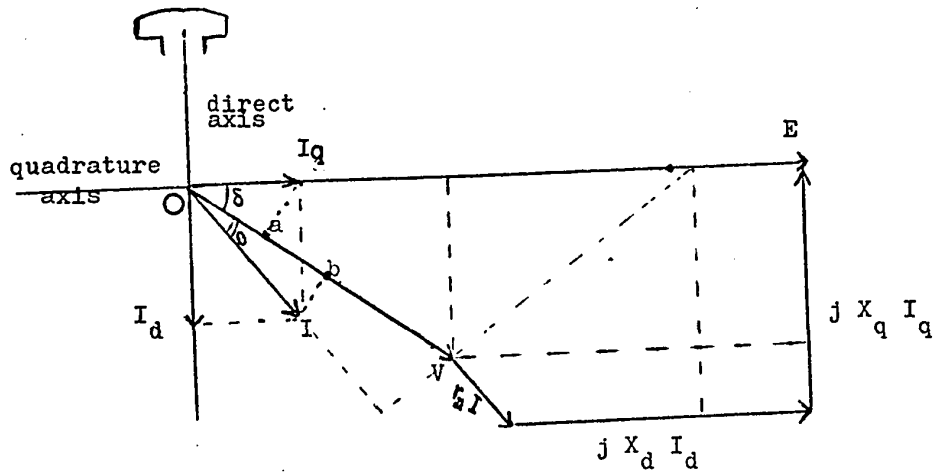

Fig. 1.8 Representation of an A.C. machine with saliency effect

$$E = V + I r_a + j X_d I_d + j X_q I_q$$

where : E = voltage back of quadrature axis

X_d = direct axis reactance

X_q = quadrature axis reactance

I_d = direct axis current

I_q = quadrature axis current

The phasor diagram of salient-pole machine is given in fig. 1.8.

1.4.4 Output Power of Generator [5]

The development of the output power equation for the two types of machine mentioned above, is as follows

1. Salient pole machine. By definition, the output power is:

$$P = V I \cos \theta$$

$$\begin{aligned} \text{From fig. 1.8, we have : } \quad I \cos \theta &= Ob = Oa + ab \\ &= I_q \cos \delta + I_d \sin \delta \end{aligned}$$

If the armature resistance r_a is negligible, as usual the case,

then $r_a I = 0$ and

$$V \sin \delta = X_q I_q \quad \text{or} \quad I_q = \frac{V \sin \delta}{X_q}$$

$$V \cos \delta = E - I_d X_d \quad \text{or} \quad I_d = \frac{E - V \cos \delta}{X_d}$$

$$\begin{aligned} P \text{ becomes : } \quad P &= V I \cos \theta = V I_q \cos \delta + V I_d \sin \delta \\ &= V \frac{V \sin \delta \cos \delta}{X_q} + V \frac{(E - V \cos \delta)}{X_d} \sin \delta \end{aligned}$$

$$P = \frac{V^2 \sin \delta \cos \delta}{X_q} + \frac{V E \sin \delta}{X_d} - \frac{V^2 \sin \delta \cos \delta}{X_d}$$

$$\text{but} \quad \sin 2\delta = 2 \sin \delta \cos \delta$$

hence
$$P = \frac{V^2}{2 X_q} \sin 2\delta - \frac{V^2}{2 X_d} \sin 2\delta + \frac{V E \sin \delta}{X_d}$$

$$P = \frac{V E \sin \delta}{X_d} + \frac{V^2 (X_d - X_q)}{2 X_d X_q} \sin 2\delta \quad (1.1)$$

This is the output power of an A.C. generator in steady-state operation.

1.2 Cylindrical rotor machine. In this case, since $X_d = X_q$, the equation (1.1) reduces to

$$P = \frac{V E \sin \delta}{X_d} \quad (1.2)$$

1.5 Power Transformer [4]

We are only concerned with big transformers used in power transmission; all other transformers are small and used only in distribution networks. Only 2-winding transformers and 3-winding transformers are discussed below.

1.5.1 Two-winding transformers

This transformer is either single phase or three-phase.

The exact equivalent circuit for two-winding transformer is shown in fig. 1.9, with all impedances referred to the primary side.

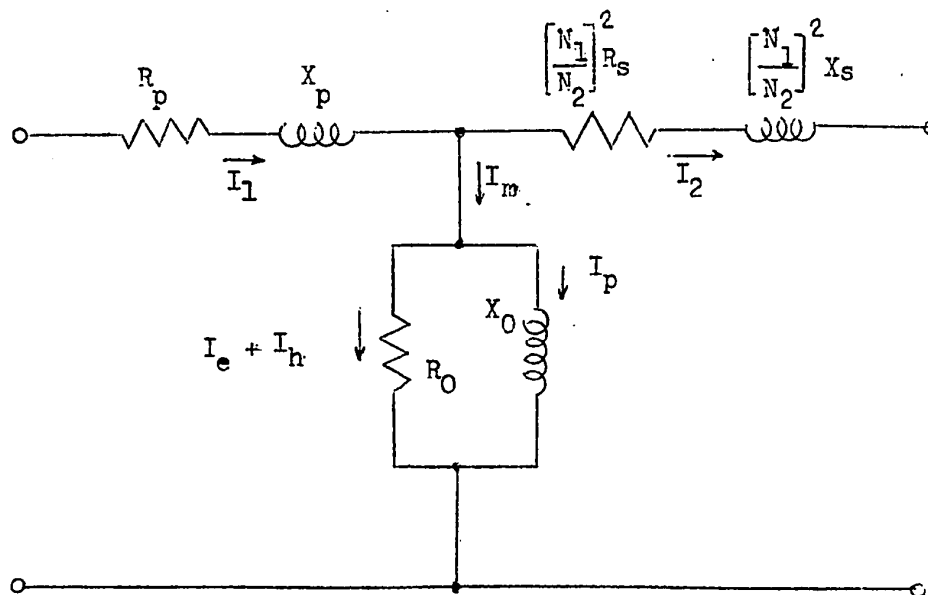

Fig. 1.9 Representation of a two-winding transformer, with impedances referred to the primary side.

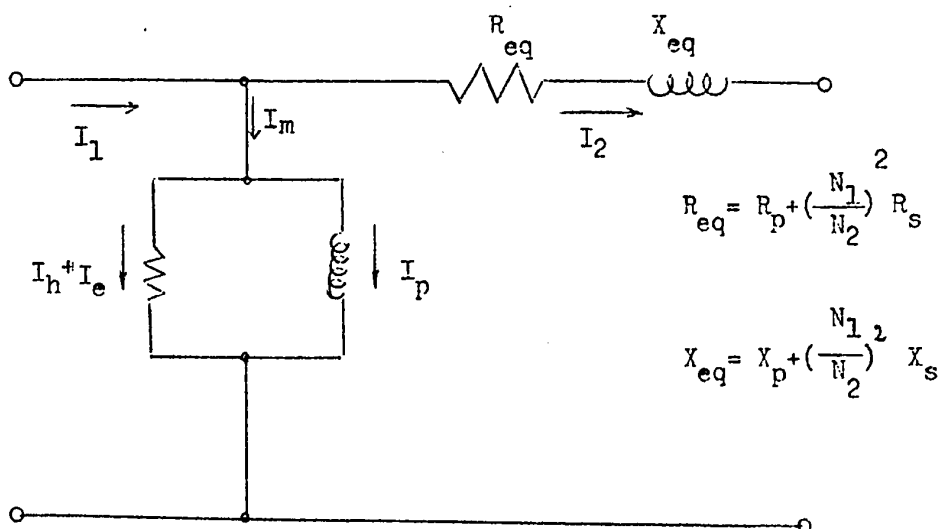

Fig. 1.10 Approximate representation of a two-winding transformer.

In fig. 1.9, we have: R_p = Resistance of primary side
 X_p = Reactance of primary side
 R_s = Resistance of secondary side
 X_s = Reactance of secondary side
 $\frac{N_1}{N_2}$ = Voltage ratio

I_m = magnetizing current required to produce the right amount of flux necessary to maintain voltage equilibrium.

I_p = current required to produce flux P in the magnetic core, if there were no hysteresis loss.

I_h = component modelling hysteresis current.

I_e = component modelling eddy current.

I_1 = primary current.

I_2 = secondary current.

If we transfer the branch containing I_m to the left, we obtain an approximate equivalent circuit of two-winding transformer, as in fig. 1.10.

This approximation is based upon the fact that $I_m \ll I_2$, and moving this branch to the left will have little effect upon the voltage drop of the series branch. Further approximation can be made with the transformer, to get more simplified equivalent circuits of the transformer, as shown in fig. 1.11.

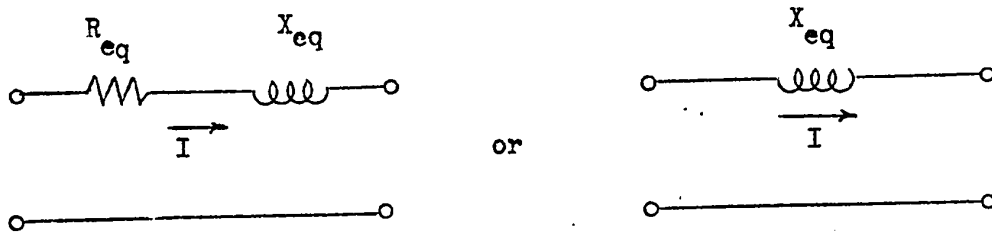

Fig. 1.11 Simplified representation of a two-winding transformer.

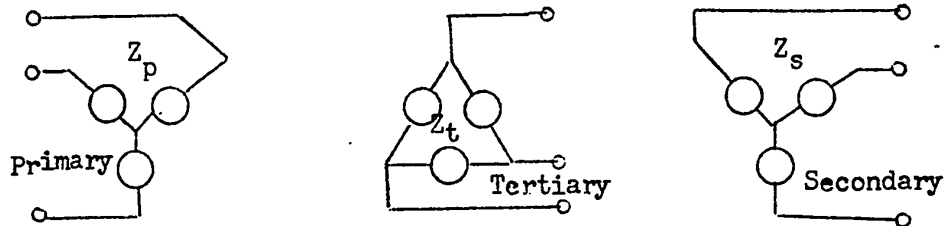

Fig. 1.12a Three-winding transformer diagram.

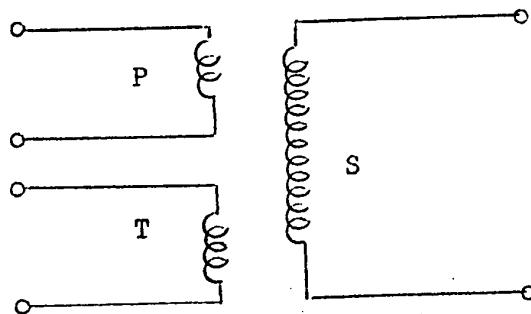

Fig. 1.12b Alternate representation of a three-winding transformer.

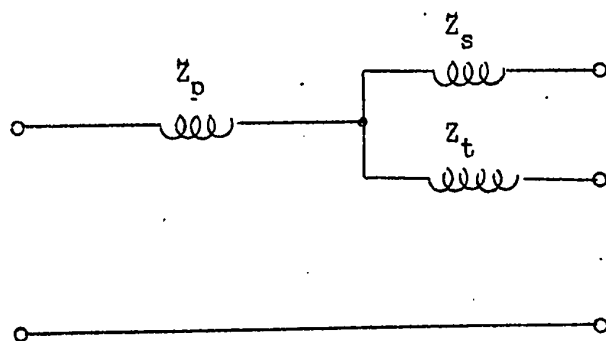

Fig. 1.13 Model of a three-winding transformer.

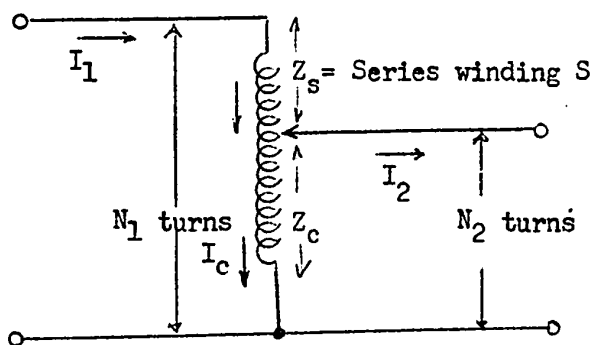

Fig. 1.14 Auto-transformer representation.

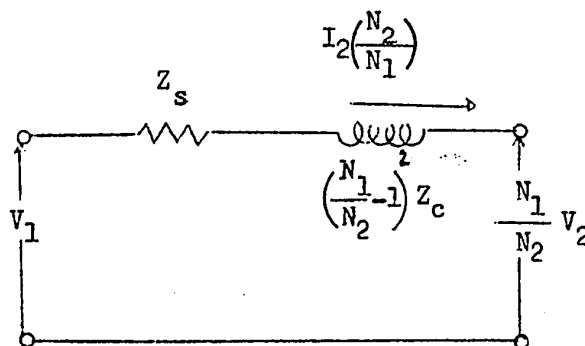

Fig. 1.15 Equivalent circuit of an auto-transformer

1.5.2 Three-winding transformers

This type of transformer is shown in fig. 1.12 a. Other representations of three-winding transformers are shown in fig. 1.12 b and in fig. 1.13. From fig. 1.12 a, Z_p , Z_s , Z_t = equivalent impedance of each winding, obtained by tests.

By setting up tests, we can have:

$$Z_{ps} = Z_p + Z_s$$

$$Z_{pt} = Z_p + Z_t$$

$$Z_{st} = Z_s + Z_t$$

Where : Z_{ps} = impedance of the primary side, when the secondary is short-circuited and the tertiary is open.

Z_{pt} = impedance of the primary, when the tertiary is short-circuited and the secondary open.

Z_{st} = impedance of the secondary, when the tertiary is short-circuited and the primary open.

The solution of the equations mentioned above, gives:

$$Z_p = \frac{1}{2} (Z_{ps} + Z_{pt} - Z_{st})$$

$$Z_s = \frac{1}{2} (Z_{ps} + Z_{st} - Z_{pt}) \quad (1.3)$$

$$Z_t = \frac{1}{2} (Z_{st} + Z_{pt} - Z_{ps})$$

1.5.3 Auto-transformer

The auto-transformer representation is shown in fig. 1.14. It may be represented as a simple series impedance Z_{eq} referred to the primary side, as in fig. 1.15. Z_{3q} can be found by a short-circuit test.

From machine theory, it is determined that: $Z_{eq} = Z_s + \left(\frac{N_1}{N_2} - 1 \right)^2 Z_c$.

1.5.4 Load Tap Changing Transformer

Some transformers are equipped with motor to change taps under load conditions. This feature is useful to regulate voltage by raising or lowering voltage, depending on load conditions. See fig. 1.16.

1.6 Representation of Power Lines [1]

Lines representation is based upon their length and the accuracy required. The actual line is a distributed parameter circuit and is represented in fig. 1.17. Lines are classified as short, medium and long.

- a) Short line (< 50 miles) representation is given in fig. 1.18
- b) Medium line (50 < X < 150 miles) is shown in fig. 1.19
- c) Long line (> 150 miles) is seen in fig. 1.20

The following development assumes distributed parameters.

Let : R = line resistance per unit length

C = line capacitance per unit length

G = line conductance per unit length

L = line inductance per unit length

X = length of line

then : characteristic impedance Z_{ω} is defined as :

$$Z_{\omega} \triangleq \sqrt{\frac{R + j\omega L}{G + j\omega C}} \quad (1.4)$$

and the propagation constant γ is defined as :

$$\gamma \triangleq \sqrt{(R + j\omega L)(G + j\omega C)} \quad (1.5)$$

and the equivalent circuit of a long line is represented in fig. 1.21.

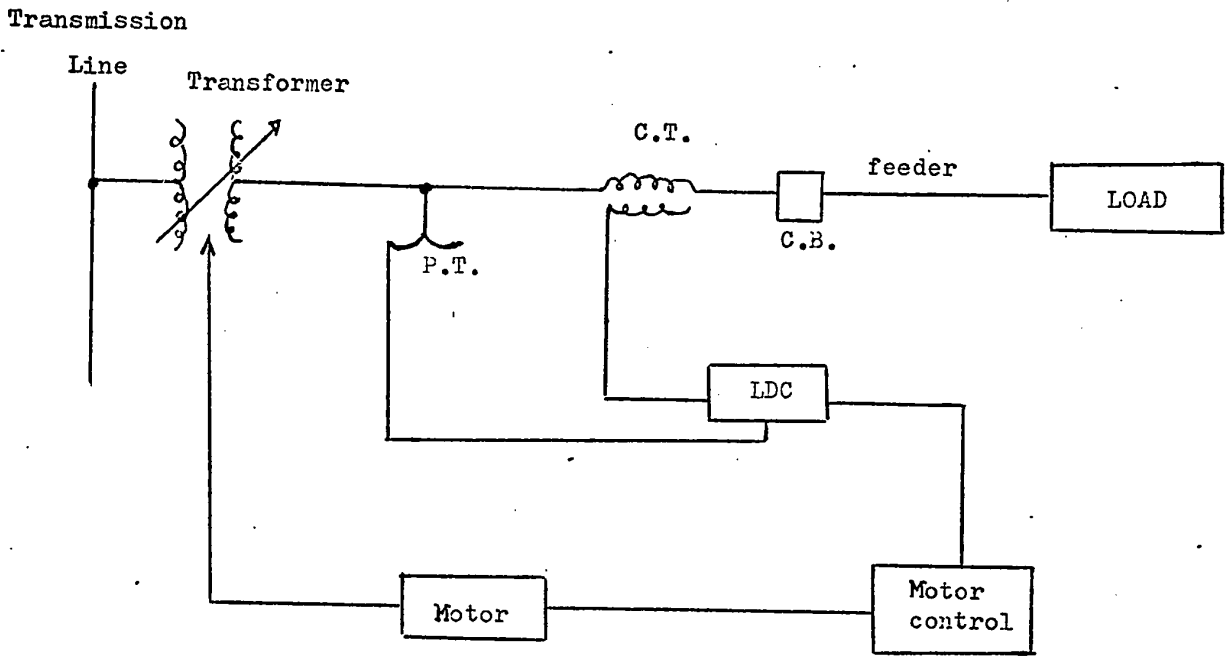

Fig. 1.16 A tap changing transformer representation

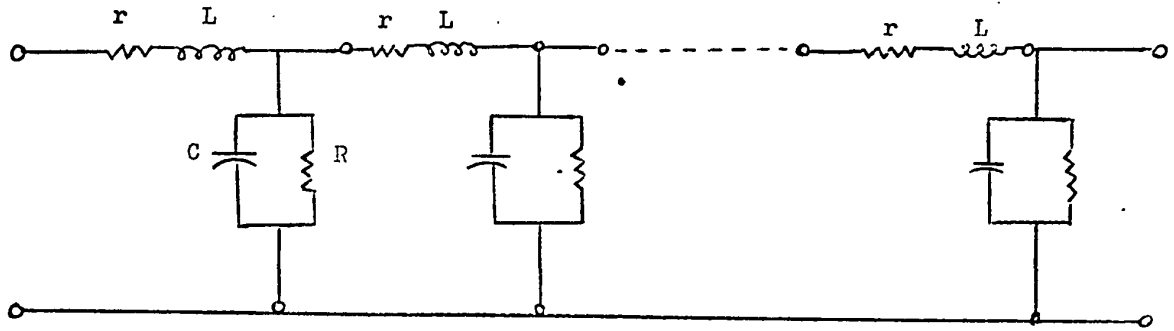

Fig. 1.17 Actual power line representation

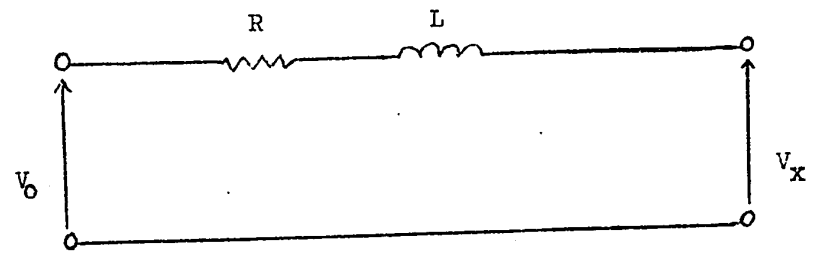
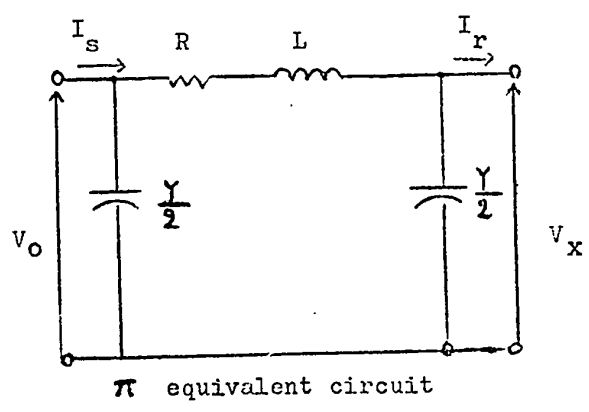

Fig. 1.18 Short line representation



or

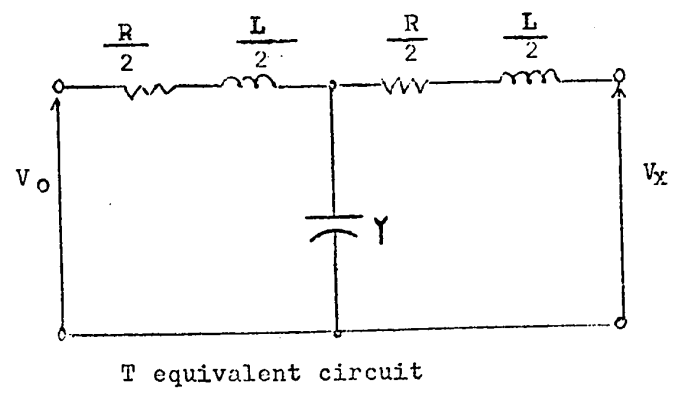

Fig. 1.19 Medium line representation

From fig. 1.20, a section dx has :

$$\text{series impedance} = dZ = (R + j\omega L) dx$$

$$\text{shunt admittance} = dY = (G + j\omega C) dx$$

At the sending end, the voltage and current are : V_x and I_x ; those of the receiving end are : $V_x + dV_x$ and $I_x + dI_x$.

The difference in voltage current at the 2 ends is caused by voltage drop dZ :

$$V_x - (V_x + dV_x) = I_x dZ$$

$$I_x - (I_x + dI_x) = V_x dY$$

or :

$$-dV_x = I_x dZ = I_x (R + j\omega L) dx$$

$$-dI_x = V_x dY = V_x (G + j\omega C) dx$$

or :

$\frac{dV_x}{dx} = -(R + j\omega L) I_x$	(1.6)
--	---------

$\frac{dI_x}{dx} = -(G + j\omega C) V_x$	(1.7)
--	---------

By differentiating (1.6) and (1.7) , we have :

$\frac{d^2 V_x}{dx^2} = -(R + j\omega L) \frac{dI_x}{dx} = + (R + j\omega L) (G + j\omega C) V_x$	(1.8)
$\frac{d^2 I_x}{dx^2} = -(G + j\omega C) \frac{dV_x}{dx} = (G + j\omega C) (R + j\omega L) I_x$	(1.9)

Using the propagation constant and the wave impedance introduced earlier:

$$Z_w = \sqrt{\frac{R + j\omega L}{G + j\omega C}} \quad ; \quad \gamma = \sqrt{(R + j\omega L) (G + j\omega C)}$$

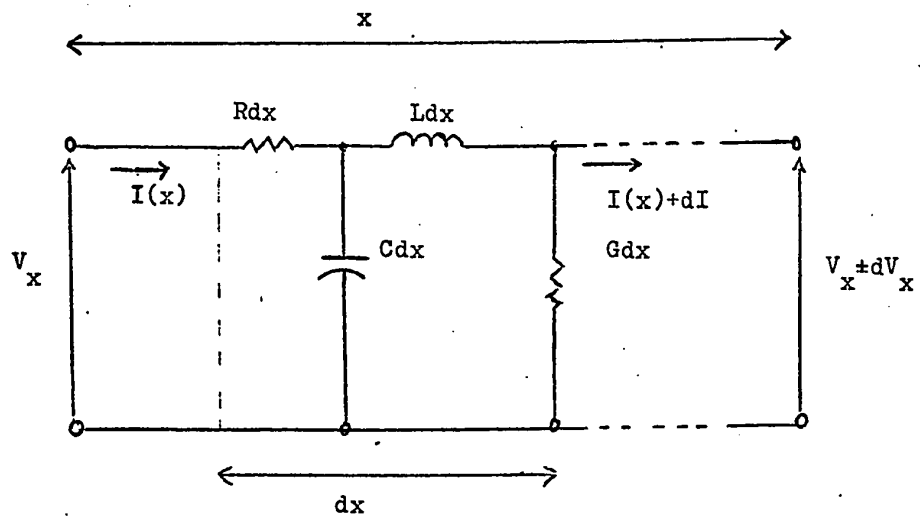

Fig. 1.20 Long line representation

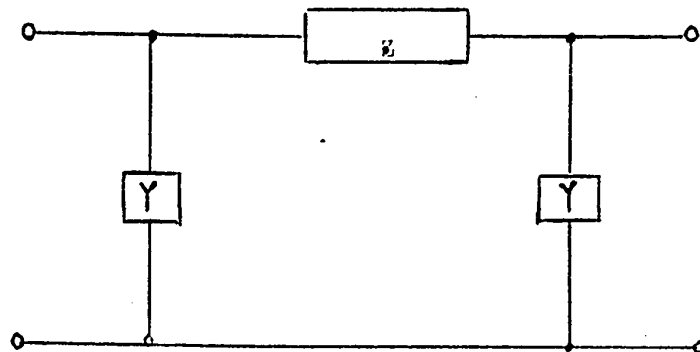

Fig. 1.21 π Equivalent circuit of a long line

We can write (1.8) and (1.9) as :

$$\boxed{\begin{aligned}\frac{d^2 V_x}{dx^2} &= \gamma^2 V_x \\ \frac{d^2 I_x}{dx^2} &= \gamma^2 I_x\end{aligned}} \quad (1.10)$$

Solving (1.10) yields :

$$\boxed{\begin{aligned}V_x &= A \cosh \gamma x + B \sinh \gamma x \\ I_x &= C \cosh \gamma x + D \sinh \gamma x\end{aligned}} \quad (1.11)$$

Constants A,B,C,D are determined from initial conditions V_0 and I_0

If $x=0$, then (1.11) becomes :

$$\begin{aligned}V_0 &= A(1) + B(0) & \text{or} & \quad A = V_0 \\ I_0 &= C(1) + D(0) & \text{or} & \quad C = I_0\end{aligned}$$

By differentiating (1.11) and comparing with (1.6) and (1.7), we have:

$$\boxed{\frac{dV_x}{dx} = A\gamma \sinh \gamma x + B\gamma \cosh \gamma x = -(R + j\omega L) I_x} \quad (1.11 a)$$

Let $x = 0$. Then (1.11 a) becomes :

$$0 + B\gamma = -(R + j\omega L) I_0$$

$$\text{or : } B\sqrt{(R + j\omega L)(G + j\omega C)} = -(R + j\omega L) I_0$$

$$B = \frac{-(R + j\omega L)}{\sqrt{(R + j\omega L)(G + j\omega C)}} I_0$$

$$B = -\sqrt{\frac{R + j\omega L}{G + j\omega C}} I_0$$

$$B = -Z_{\omega} I_0 \quad (1.12)$$

If a similar operation is done on the second equation of (1.11), we get :

$$D = -\frac{V_0}{Z_{\omega}} \quad (1.13)$$

Hence, equation (1.11) can be written now:

$$V_x = V_0 \cosh \gamma x - Z_{\omega} I_0 \sinh \gamma x \quad (a) \quad (1.14)$$

$$I_x = I_0 \cosh \gamma x - \frac{V_0}{Z_{\omega}} \sinh \gamma x \quad (b)$$

Let consider now the equivalent circuit of fig. 1.22, from which:

$$V_x = V_0 - Z (I_0 - Y_1 V_0) \quad (1.15)$$

and

$$I_x = I_0 - Y_1 V_0 - Y_2 V_x \quad (1.16)$$

Equation (1.15) can be written as :

$$V_x = V_0 (1 + Z Y_1) - Z I_0$$

and (1.16) becomes :

$$I_x = I_0 - Y_1 V_0 - Y_2 \left[V_0 (1 + Z Y_1) - Z I_0 \right]$$

$$= I_0 - Y_1 V_0 - Y_2 V_0 - Y_2 V_0 Z Y_1 + Y_2 Z I_0$$

$$I_x = I_0 (1 + Z Y_2) - V_0 (Y_1 + Y_2 + Z Y_1 Y_2) \quad (1.17)$$

If we compare (1.17) with (1.14 b) we get:

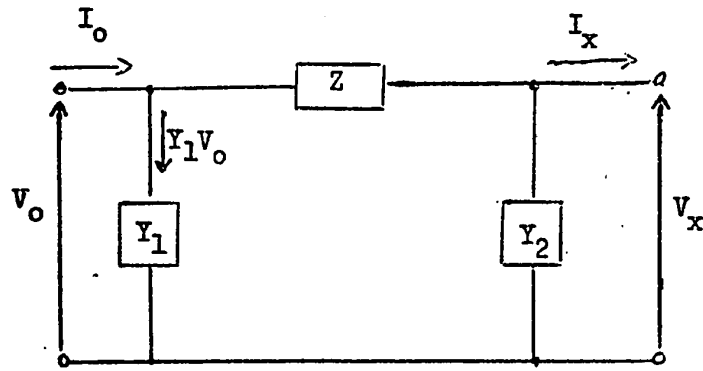

Fig. 1.22 T equivalent circuit of a long line

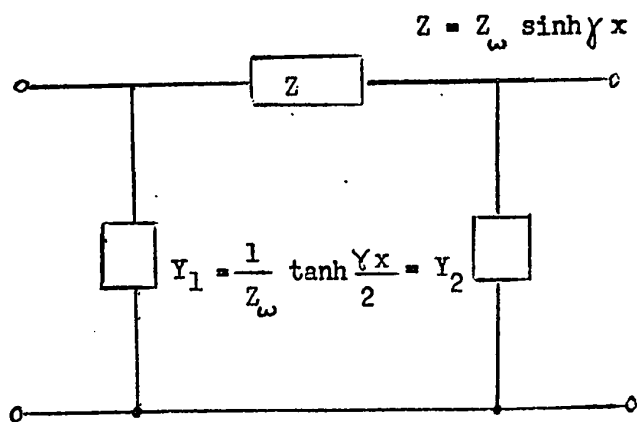

Fig. 1.23 Detailed representation of a long line

$$1 + Z Y_2 = \cosh \gamma x \quad (1.18)$$

$$Y_1 + Y_2 + Z Y_1 Y_2 = \frac{\sinh \gamma x}{Z_\omega} \quad (1.19)$$

If we choose $Y_1 = Y_2$, then (1.18) and (1.19) become:

$$1 + Z Y_1 = 1 + Z Y_2 = \cosh \gamma x \quad (1.20)$$

$$2Y_1 + Z Y_1^2 = \frac{\sinh \gamma x}{Z_\omega} \quad (1.21)$$

The solution of (1.20) and (1.21) gives:

$$\begin{aligned} Z &= Z_\omega \sinh \gamma x \\ Z_1 = Z_2 &= \frac{1}{Z_\omega} \frac{\cosh \gamma x - 1}{\sinh \gamma} = \frac{1}{Z_\omega} \tanh \frac{\gamma x}{2} \end{aligned} \quad (1.22)$$

These values are now shown in the equivalent circuit of a long line given in fig. 1.23.

CHAPTER 2

SELECTED NETWORK CONCEPTS
AND NETWORK EQUATIONS.

2.1 Instantaneous power p

Consider the circuit of fig.2.1 ,and assume that:

$$v = V_m \sin (\omega t + \theta)$$

$$i = I_m \sin \omega t$$

From fig. 2.2 the instantaneous power is defined as:

$$\begin{aligned} p = v i &= V_m \sin (\omega t + \theta) I_m \sin \omega t \\ &= V_m I_m \sin \omega t (\sin \omega t \cos \theta + \cos \omega t \sin \theta) \\ &= V_m I_m \sin^2 \omega t \cos \theta + V_m I_m (\sin \omega t \cos \theta t) \sin \theta \\ p &= (V_m I_m / 2) \cos \theta - (V_m I_m / 2) (\cos 2\omega t) \cos \theta + (V_m I_m / 2) (\sin \omega t) \sin \theta \end{aligned}$$

Since the average value of $\cos 2\omega t$ and $\sin 2\omega t$ terms is equal to zero when considered over a time interval equal to an integral number of cycles, the average power $P_{av} = \frac{V_m I_m}{2} \cos \theta$, and the effective power

becomes:

$$P = \frac{V_m I_m}{\sqrt{2} \sqrt{2}} \cos \theta = V I \cos \theta = \text{real power}$$

$$\boxed{P = V I \cos \theta} \quad \text{watts}$$

The reactive power Q is defined as:

$$\boxed{Q = V I \sin \theta} \quad \text{vars}$$

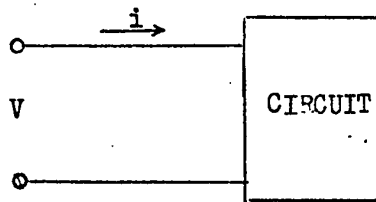

Fig.2.1 A simple circuit.

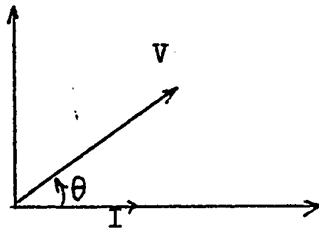

Fig.2.2 Phasor Diagram of the circuit of Fig.2.1

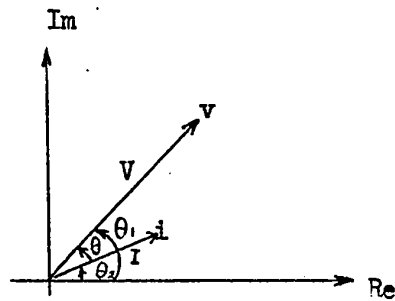

Fig.2.3 Complex Representation of circuit of Fig.2.1

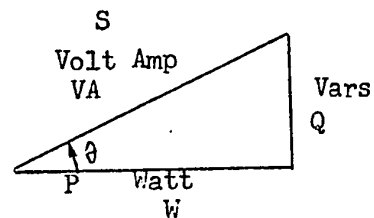

Fig.2.4 Power Triangle Representation

2.2 Complex Power

From fig. 2.3 :

$$v = V e^{j\theta t}$$

$$i = I e^{j\theta t}$$

$$e^{j\theta t} = \cos \theta t + j \sin \theta t$$

Form the product: $S = V^* I$ where V^* = conjugate of V

$$\begin{aligned} V^* I &= V e^{-j\theta t} \cdot I e^{j\theta t} = V I e^{j(\theta_1 - \theta_2)} = V I e^{-j\theta t} \\ &= V I (\cos \theta - j \sin \theta) = V I \cos \theta - j V I \sin \theta \end{aligned}$$

But: $V I \cos \theta = P$ and $V I \sin \theta = Q$;

hence : $V^* I = P - jQ$

If we form another product $V I^*$, we get:

$$\boxed{V I^* = P + j Q = S} \quad (2.1)$$

The form $S = V I^*$ = complex power is the convention adopted by the International Electrotechnical Commission. With this convention, inductive vars will be considered positive and capacitive vars will be considered negative. The power triangle for equation (2.1) is shown in fig.2.4.

The reactive power Q is generated by: overexcited synchronous machines, capacitors, cables and lightly loaded overhead lines.

The reactive power Q is absorbed by: under-excited synchronous machines, induction motors, inductors, transformers and heavily loaded overhead lines.

2.3 Calculation of sending and receiving voltages in terms of power and reactive power. [5]

A simple link is shown in fig. 2.5, and its phasor diagram is shown in fig. 2.6. From fig. 2.6, we have:

$$E^2 = (V + \Delta V)^2 + (\delta V)^2 \quad (2.2)$$

but: $\Delta V = R I \cos \theta + I X \sin \theta$

and: $\delta V = I X \cos \theta - R I \sin \theta$

hence $E^2 = (V + R I \cos \theta + I X \sin \theta)^2 + (I X \cos \theta - R I \sin \theta)^2$

but $P = V I \cos \theta$ or $I \cos \theta = P/V$

$Q = V I \sin \theta$ or $I \sin \theta = Q/V$

and $E^2 = (V + R \frac{P}{V} + X \frac{Q}{V})^2 + (X \frac{P}{V} - R \frac{Q}{V})^2 \quad (2.3)$

Now compare (2.2) with (2.3); we have:

$$\Delta V = \frac{RP + XQ}{V} \quad (2.4)$$

$$\delta V = \frac{XP - RQ}{V} \quad (2.5)$$

If $\delta V \leq V + \Delta V$, then:

$$E^2 = (V + \frac{RP + XQ}{V})^2$$

and $E - V = \Delta V = \frac{RP + XQ}{V} \quad (2.6)$

If $R = 0$, then ΔV becomes: $\Delta V = \frac{X}{V} Q$ and $\delta V = \frac{X}{V} P$

Since $X/V = \text{constant } k$, now we get:

$$\begin{array}{l} \Delta V = kQ \\ \delta V = kP \end{array} \quad (2.7)$$

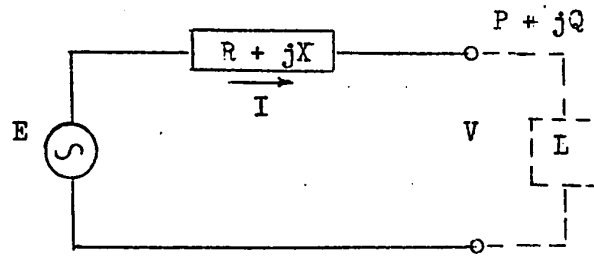

Fig.2.5 Representation of a simple link.

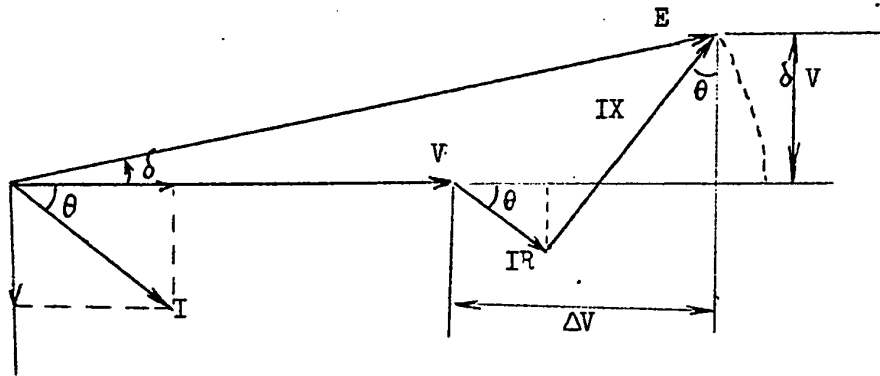
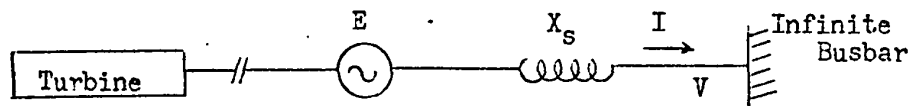
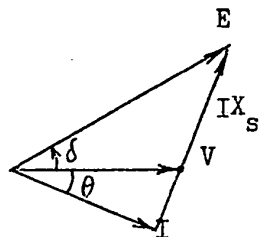

Fig.2.6 Phasor diagram of a simple link.



(a)



(b)

Fig.2.7 A Generator Representation (a), and its Phasor Diagram (b).

As seen from equation (2.7) : in most circuits, the voltage difference determines the reactive power, and the angle difference determines the real power.

2.4 The Power Transfer Equation of a Generator. [5]

Consider a generator connected to an infinite bus (as shown in fig. 2.7a) : when this machine is disconnected from the power system and if the remaining machines in the system are not affected, then this machine is said to be connected to an infinite busbar.

The angle δ is load angle and is dependent on the power input from the turbine shaft.

When an isolated machine supplies its own load, the latter dictates the power required, hence the load angle. When connected to an infinite busbar system, however, the load delivered by the machine is no longer directly dependent on the connected load.

By changing the turbine output and hence δ , the generator can be made to take any load, subject to economic and technical limits.

From fig. 2.7b, let us consider the triangle OVE, and use a trigonometric formula:

$$\frac{E}{\sin (90^\circ + \theta)} = \frac{IX_s}{\sin \delta}$$

or $I \cos \theta = \frac{E}{X_s} \sin \delta$

multiply by V: $V I \cos \theta = \frac{VE}{X_s} \sin \delta$ or:

$$\boxed{P = \frac{VE}{X_s} \sin \delta} \quad (2.8)$$

This is the power delivered to a system by a generator.

When $\delta = 90^\circ$, the maximum power is:

$$P_m = \frac{VE}{X_s} \quad (2.9)$$

which is also called the steady-state stability limit of the machine.

The load angle δ has a physical significance: it is not only the electrical angle between E and V, but it is also the approximate angle between the pole center and the physical reference axis for the open-circuit condition. This is shown in fig. 2.8.

2.5 Summary of some Main Network Equations in Matrix Form.

2.5.1 Introduction.

Consider the network of fig. 2.9, and apply Kirchoff Law to nodes 1,2,3:

$$\begin{aligned} J_1 &= V_1 Y_1 + (V_1 - V_2) Y_5 + (V_1 - V_3) Y_4 \\ J_2 &= V_2 Y_2 + (V_2 - V_1) Y_5 + (V_2 - V_3) Y_6 \\ J_3 &= V_3 Y_3 + (V_3 - V_1) Y_4 + (V_3 - V_2) Y_6 \end{aligned} \quad (2.10)$$

Introducing the following admittances:

$$\begin{aligned} y_{11} &= Y_1 + Y_4 + Y_5 & ; & & y_{23} = y_{32} = -Y_6 \\ y_{22} &= Y_2 + Y_5 + Y_6 & ; & & y_{13} = y_{31} = -Y_4 \\ y_{33} &= Y_3 + Y_4 + Y_6 & ; & & y_{12} = y_{21} = -Y_5 \end{aligned}$$

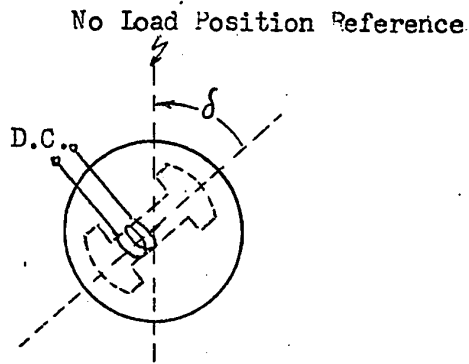

Fig.2.8 Representation of a Rotor of an A.C. Generator

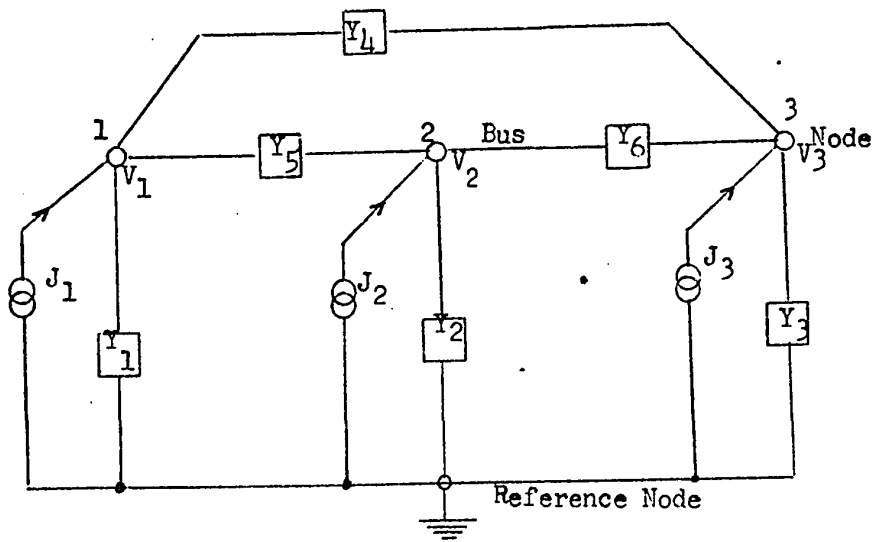

Fig.2.9 A simple Network.

Equation (2.10) now can be written as:

$$\begin{bmatrix} J_1 \\ J_2 \\ J_3 \end{bmatrix} = \begin{bmatrix} y_{11} & y_{12} & y_{13} \\ y_{21} & y_{22} & y_{23} \\ y_{31} & y_{32} & y_{33} \end{bmatrix} \begin{bmatrix} V_1 \\ V_2 \\ V_3 \end{bmatrix} \quad (2.11)$$

For n nodes, by generalization:

$$\begin{bmatrix} J_{bus} \end{bmatrix} = \begin{bmatrix} Y_{bus} \end{bmatrix} \begin{bmatrix} V_{bus} \end{bmatrix} \quad (2.12)$$

where:

$$\begin{aligned} J_{bus} &= \text{Bus Current Vector} \\ Y_{bus} &= \text{Nodal Bus Admittance Matrix} \\ V_{bus} &= \text{Bus Voltage Vector} \end{aligned}$$

2.5.2 Summarized Technique to Find Network Impedances & Admittances.

For a given network, with given branch impedances Z_1, Z_2, \dots, Z_n or admittances Y_1, Y_2, \dots, Y_n (where n is the number of elements) choose the arbitrary directions of branch and loop currents.

1- Find Z and Y by forming:

$$\text{Primitive Impedance Matrix } [Z] = \begin{bmatrix} Z_1 & 0 & \dots & 0 \\ 0 & Z_2 & \dots & 0 \\ \vdots & \vdots & \ddots & \vdots \\ 0 & 0 & \dots & Z_n \end{bmatrix}$$

$$\text{or Primitive Admittance Matrix } [Y] = [Z]^{-1}$$

2- In Loop Frame:

- a) Find loop incidence matrix C given by forming relations between I branch and I loop currents:

$$I_b = C I_{loop} \quad \text{where } C = [\text{branches} \times \text{loops}]$$

- b) Z_{loop} now is given by:

$$\boxed{[Z_{loop}] = [C^T] [Z] [C]} \quad (2.13)$$

3- In Bus Frame: Choose one bus as reference

- a) Find bus incidence matrix A given by forming relations between branch and bus voltages:

$$V_b = A V_{bus} \quad \text{where } A = [\text{branches} \times \text{buses}]$$

- b) Y_{bus} is now given by:

$$\boxed{[Y_{bus}] = [A^T] [Y] [A]} \quad (2.14)$$

The Z_{loop} and Y_{bus} are usually known in Kirchoff's Laws as:

$$[Z_{loop}][I_{loop}] = [E_{loop}] \quad \text{and} \quad [E_{nodes}][Y_{bus}] = [J_{nodes}]$$

2.5.3 Application

Let us apply this method to the circuit of fig. 2.9.

- 1- Find Z and Y

$$Z = \begin{bmatrix} Z_1 & & & & & & \\ & Z_2 & & & & & \\ & & Z_3 & & & & \\ & & & Z_4 & & & \\ & & & & Z_5 & & \\ & & & & & Z_6 & \\ & & & & & & \end{bmatrix}$$

$$[Y] = [Z]^{-1} = \begin{bmatrix} 1/Z_1 & & & & & \\ & 1/Z_2 & & & & \\ & & 1/Z_3 & & & \\ & & & 1/Z_4 & & \\ & & & & 1/Z_5 & \\ & & & & & 1/Z_6 \end{bmatrix}$$

2- Network Variables in Loop Frame of Reference

a) Loop current = I_{loop}

The circuit of fig.2.9 can be redrawn as shown in fig. 2.10

$$I_{\text{branch}} = I_b = I \text{ in each branch a,b,c,....}$$

$$I_{\text{loop}} = [I_1 \ I_2 \ I_3]^T$$

b) Loop Incidence Matrix C

By forming a matrix C with number of loops as columns, and number of branches (a,b,c,d,e,f) as rows:

$$I_b \text{ in branch a} = -I_1 - I_3$$

$$I_b \text{ in branch b} = I_1 - I_2$$

$$I_b \text{ in branch c} = I_2 + I_3$$

$$I_b \text{ in branch d} = I_3$$

$$I_b \text{ in branch e} = I_1$$

$$I_b \text{ in branch f} = I_2$$

$$C = \begin{array}{c|ccc} & \text{loops} & & \\ & 1 & 2 & 3 \\ \hline \text{a} & -1 & 0 & -1 \\ \text{b} & 1 & -1 & 0 \\ \text{c} & 0 & 1 & 1 \\ \text{d} & 0 & 0 & 1 \\ \text{e} & 1 & 0 & 0 \\ \text{f} & 0 & 1 & 0 \end{array}$$

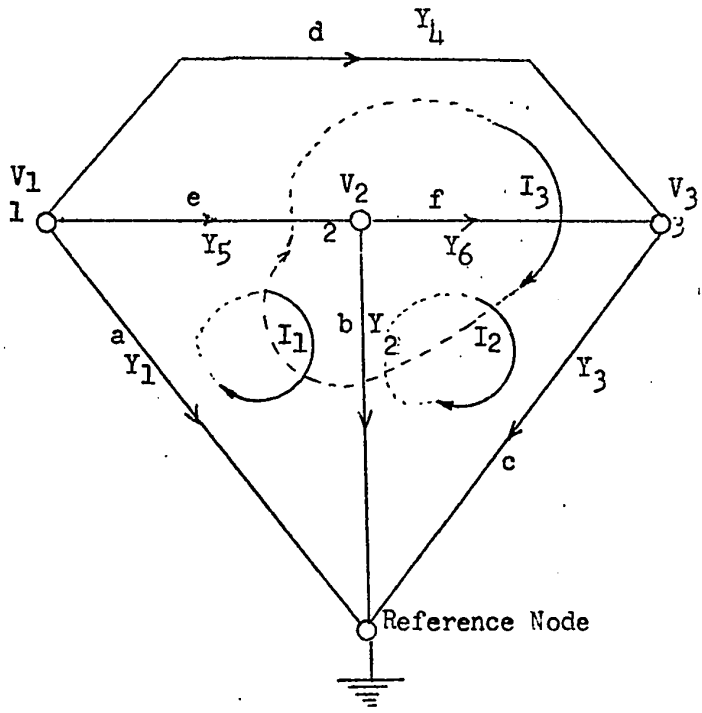

Fig.2.10 Circuit of Fig. 2.9 redrawn.

hence $I_{\text{branch}} = C I_{\text{loop}}$ (2.15)

and $Z_{\text{loop}} = C^T Z C$

$$Z_{\text{loop}} = \begin{bmatrix} -1 & 1 & 0 & 0 & 1 & 0 \\ 0 & -1 & 1 & 0 & 0 & 1 \\ -1 & 0 & 1 & 1 & 0 & 0 \end{bmatrix} \begin{bmatrix} z_1 & z_2 & z_3 & z_4 & z_5 & z_6 \\ \circ & & & & & \\ & \circ & & & & \\ & & & & & \end{bmatrix} \begin{bmatrix} -1 & 0 & -1 \\ 1 & -1 & 0 \\ 0 & 1 & 1 \\ 0 & 0 & 1 \\ 1 & 0 & 0 \\ 0 & 1 & 0 \end{bmatrix}$$

$$Z_{\text{loop}} = \begin{bmatrix} z_1 + z_2 + z_5 & -z_2 & z_1 \\ -z_2 & z_2 + z_3 + z_6 & z_3 \\ z_1 & z_3 & z_1 + z_3 + z_4 \end{bmatrix}$$

3- Network Variables in Bus Frame of Reference

a) Bus Incidence Matrix A

$V_1, V_2, V_3 =$ Bus Voltages

- V branch a = V_1
- V b = V_2
- V c = V_3
- V d = $V_1 - V_3$
- V e = $V_1 - V_2$
- V f = $V_2 - V_3$

or:

$$V_{\text{branch}} = \begin{matrix} a \\ b \\ c \\ d \\ e \\ f \end{matrix} \begin{bmatrix} 1 & 0 & 0 \\ 0 & 1 & 0 \\ 0 & 0 & 1 \\ 1 & 0 & -1 \\ 1 & -1 & 0 \\ 0 & 1 & -1 \end{bmatrix} \begin{bmatrix} V_1 \\ V_2 \\ V_3 \end{bmatrix}$$

$$\text{and } V_b = A \cdot V_{\text{bus}} \quad (2.16)$$

Hence:

$$Y_{\text{bus}} = \begin{bmatrix} 1 & 0 & 0 & 1 & 1 & 0 \\ 0 & 1 & 0 & 0 & -1 & 1 \\ 0 & 0 & 1 & -1 & 0 & -1 \end{bmatrix} \begin{bmatrix} Y_1 & & & & & \\ & Y_2 & \bigcirc & & & \\ & & Y_3 & & & \\ & & & Y_4 & & \\ \bigcirc & & & & Y_5 & \\ & & & & & Y_6 \end{bmatrix} \begin{bmatrix} 1 & 0 & 0 \\ 0 & 1 & 0 \\ 0 & 0 & 1 \\ 1 & 0 & -1 \\ 1 & -1 & 0 \\ 0 & 1 & -1 \end{bmatrix}$$

$$Y_{\text{bus}} = \begin{bmatrix} Y_1 + Y_4 + Y_5 & -Y_5 & -Y_4 \\ -Y_5 & Y_2 + Y_5 + Y_6 & -Y_6 \\ -Y_4 & -Y_6 & Y_3 + Y_4 + Y_6 \end{bmatrix}$$

CHAPTER 3

BASIC DISPATCHING CENTER HARDWARE

3.1 Introduction

A basic Dispatching Center hardware consists of:

- 1- A Data Acquisition and Supervisory Control System (DASC) where data from many points of the power system (transformation substations and generating stations) are collected and transmitted to a Master Collection Station or directly to the Dispatching Center.
- 2- The Computer System where all incoming data are processed by various application programs and then the output data are displayed either on mimic board or various indicators, or logged in many recording devices.
- 3- The Display System receives data from the computer or directly from the DASC to display on various equipment. Fig. 3.1 shows a general set up of hardware in a dispatching center.

In following sections, a brief description of the above mentioned equipment is given. This will serve as an introduction to computer software and applications programs.

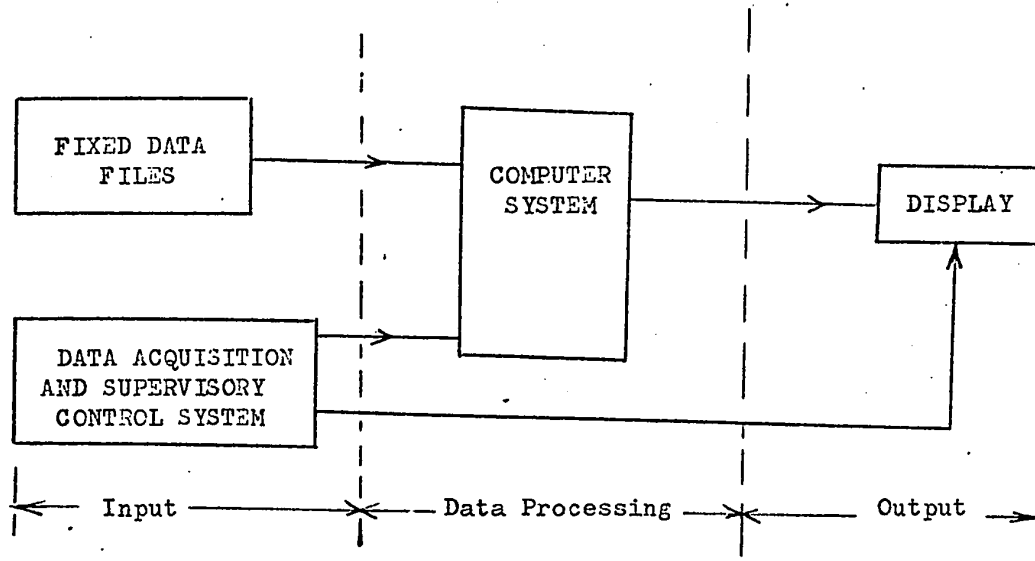

Fig.3.1 General Equipment of a Dispatching Center.

3.2 Data Acquisition and Supervisory Control or DASC Systems

3.2.1 Introduction

Any dispatching center of a power system depends on a data collection system to obtain informations from various substations and generating station, which are also known as "remote stations".

The master station where all data are gathering could be an intermediate substation or the Dispatcher Center itself.

The data acquisition usually has a minicomputer as the main component and is partitioned into 3 subsystems:

- 1- Plant Subsystem , where all data are picked up by various sensors.
- 2- Computer Subsystem , where all computations are done.
- 3- Operator or Output Subsystem, where all output data are displayed for local use or transmitted to the master station.

The data acquisition system at remote stations collects only informations, but cannot receive and execute orders from the master station. If this control option is available, then we have a supervisory control system. For the purpose of dispatching center study, we always have the 2 systems in the same package and we refer to as "The Data Acquisition and Supervisory Control System" or DASC system.

3.2.2 DASC Equipment at Remote Stations

A schematic representation of a basic data collecting system is shown in fig. 3.2 . The system is partitioned into 4 functions: Data Gathering, Signal Conditioning, Data Processing and Output Generation.

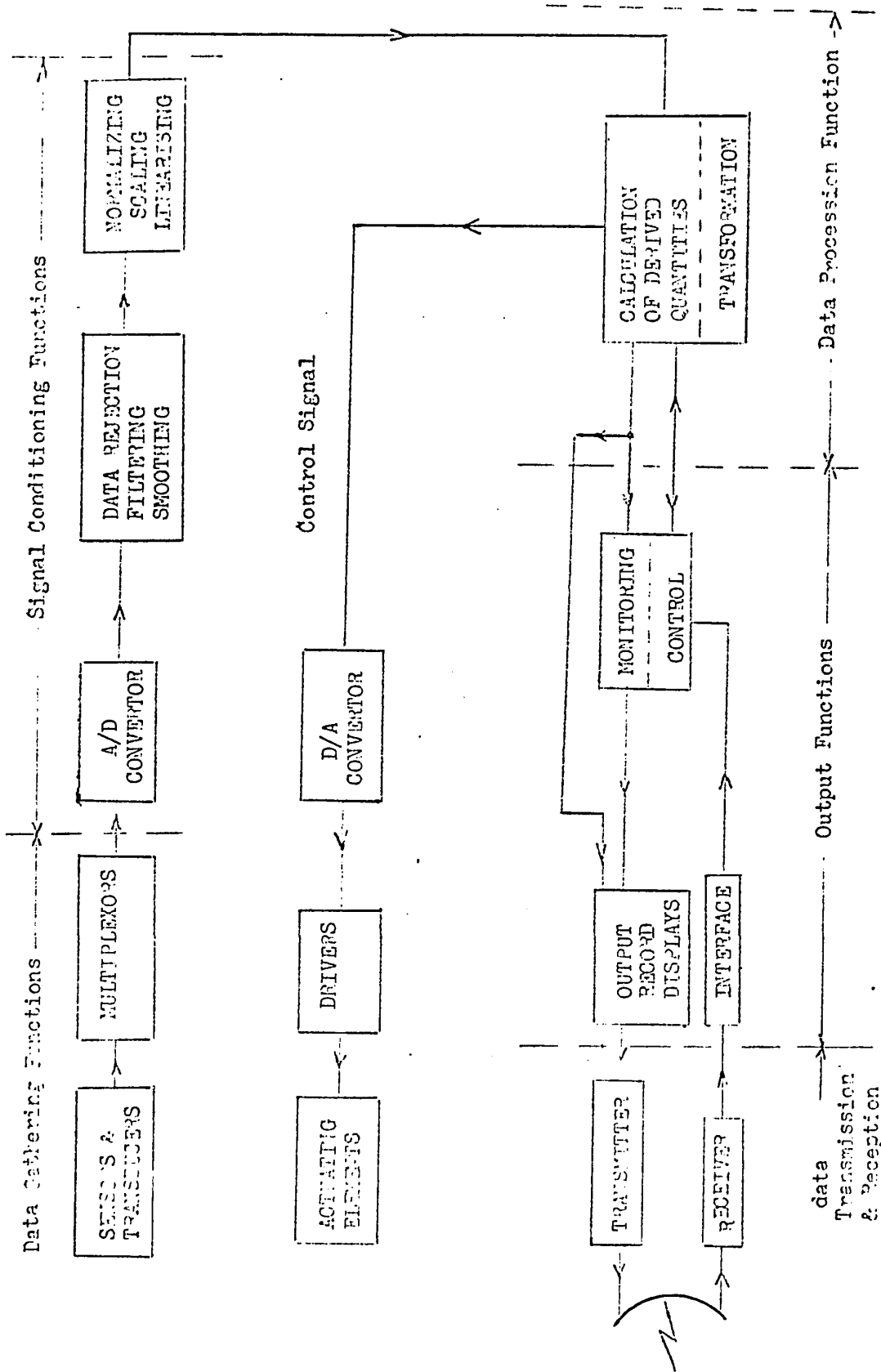

Fig.3.2 Schematic Function of the DASC Equipment installed at a Remote Station.

1- Data Gathering Function . Data gathering consists of the following basic elements:

- a) Analog sensors, which convert the variables to be measured (volts, amp, watt, vars, hydrological and meteorological data) into standardized signals (most generally in the form of a current or voltage signal proportional to the measured value). This is the "analog telemetering" .
 - b) Digital sensors, which provide a number of impulses after a certain time period. This is the most popular metering method of KWH and of power system frequency, This method is referred to as "digital telemetering".
 - c) Digital values, such as relay contacts, alarms, signalisation, etc....indicate the status of circuit breakers (open or closed), power transmission lines (under tension or not) etc. This is "telesignalisation".
 - d) Actuating elements, such as valves, motors (to raise or lower transformer taps), relays (to open or close a circuit breaker, to start or stop alternators, etc.)
 - e) Set points values, such as the KWs to be produced by each alternator, vars generated from the synchronous condensers, etc. The control of actuating elements and set point values is referred to as "telecontrol or supervisory control"
- Fig. 3.3 shows the detailed set-up of various sensors and actuating elements in a remote station.
- f) Multiplexors enable the data collection system to handle large numbers of input signals. Switching speeds may range from about 100 points/sec. for general process control appli-

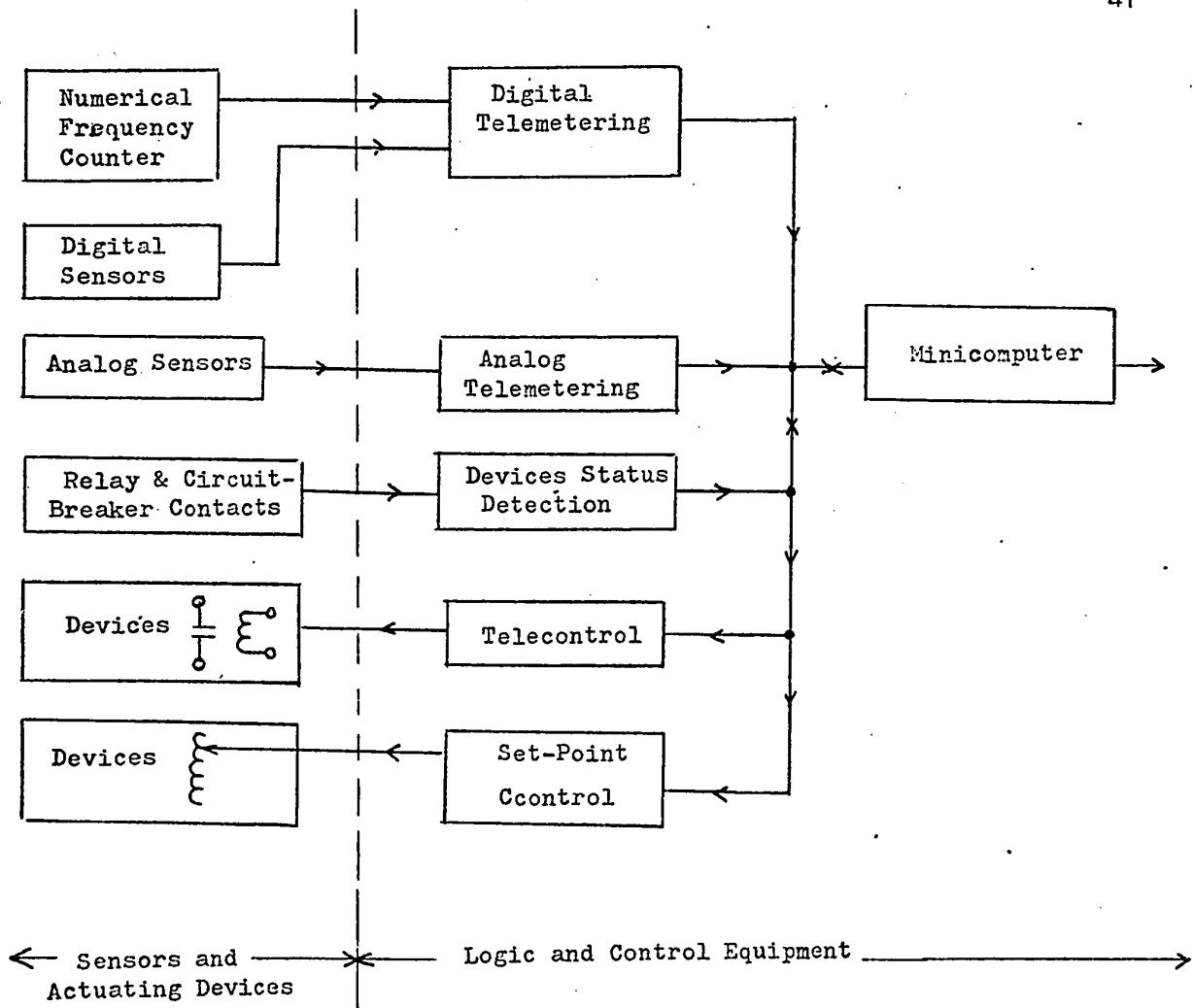

Fig.3.3 Data Gathering Functions and Control Functions at a Remote Station of DASC system.

cations to over 15,000 points/sec. in laboratory research applications.

2- Signal Conditioning Function [6] A wide range of functions may be included under the category of signal conditioning. The following are typical:

- a) Analog to Digital (A/D) Converters : convert the analog signal into the digital format required by the computer.
- b) Rejection of erratic data. Data may be corrupted by spurious noise, or by errors in the multiplexing or conversion stages. Where there is redundancy in the input information, the faulty data may be rejected through simple comparative and logic circuits.
- c) Filtering and data smoothing . Analog and digital filters are used to reduce the noise content of signal based on averaging techniques or on differences in frequency distribution between the useful signal and the noise components.
- d) Scaling and Normalizing. This includes specifying the range for each measured variable (e.g. selecting scale factor and zero suppression for each variable)
- e) Linearization . It is usually convenient to have a linear relationship between the physical variable and the signal being processed.
- f) Calibration . Many measurements may be subject to gradual changes in parameter values. This problem may be eliminated by periodic checking of readings against calibration standard..

3- Data Processing Function [6] . The following functions may be considered:

- a) Computation of derived quantities. Frequently a system variable (e.g. MWH), which cannot be directly observed but must be computed as the function of several primary variables, may be of interest. The computation of observed quantities is particularly important in applications of optimizing control.
 - b) Transformation of time-based signal. In many applications, it is useful to transform signals, through various mathematical manipulations, for subsequent interpretation. Thus we may list: Fourier transformation, frequency analysis, etc.
 - c) Monitoring of System Variables. The general function here is the comparison of the signal with predetermined limits; for example: an alarm may be triggered by a variable exceeding the limits.
 - d) Formatting for output. Special computations may be required depending upon the desired form of the output. This may include scaling and calibration routines for plotting variables as functions of time or as functions of other variables.
- 4- Output Generation Function. The output of the information processing system of the DASC may take a variety of forms and serve various purposes. Some output may be displayed for local operators but most outputs are transmitted to a master station or Dispatching Center.
- The Output Display Equipment will be discussed in detail in section 3.4

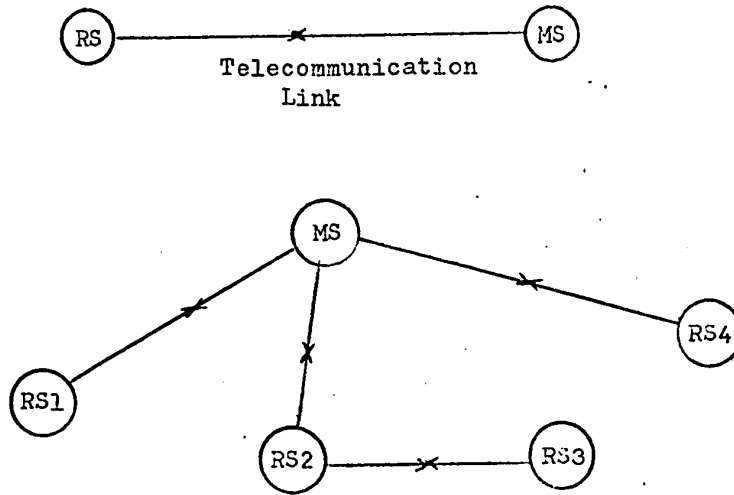

Fig. 3.4 Arrangement of Remote Stations (RS) and the Master Station (MS).

3.2.3 DASC Equipment at the Master Station (see fig. 3.5)

One of many possible set-ups of several remote stations and a master station, is shown in fig. 3.4.

The equipment of the DASC at the master station consist of the following:

- a) a Central Processing Unit controls the management and exchanges messages with all remote stations. The CPU functions are: adaptation of the transmission line; periodic scanning of all measured variables at each remote station, one after another; distribution of information to various display devices; monitoring of the equipment.
- b) a set of Output Devices. This will be discussed in the section 3.4

3.3 Computer Configuration Analysis [6]

Two general classes of processor organisation, i.e. the multicomputer and the multiprocessor, are considered.

Either is capable of availability, switchover, interprocessor communication, high level of processing capability and continuous real-time operation.

3.3.1 Multicomputer System

A multicomputer system consists of two or more independent processors, each of which can communicate with one or more processors by means of interrupts and data transfer channels.

A two-processor system is shown in fig. 3.6.

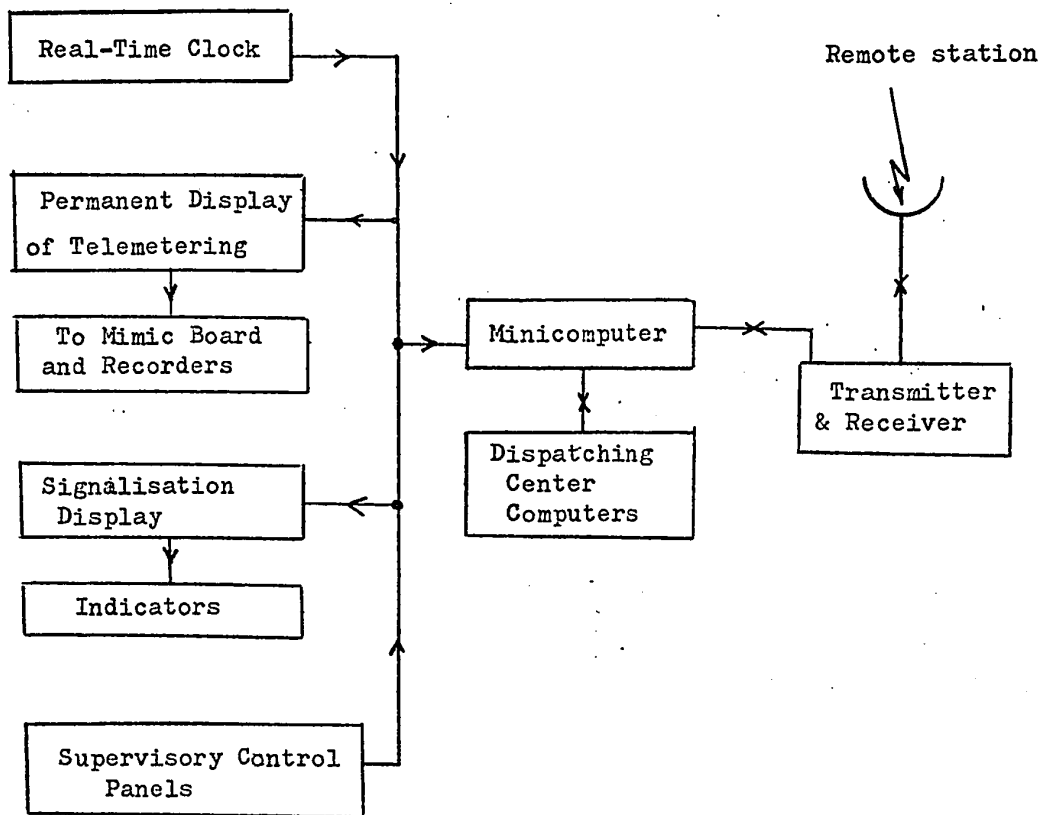

Fig.3.5 Equipment of the Master Station in the DACS system.

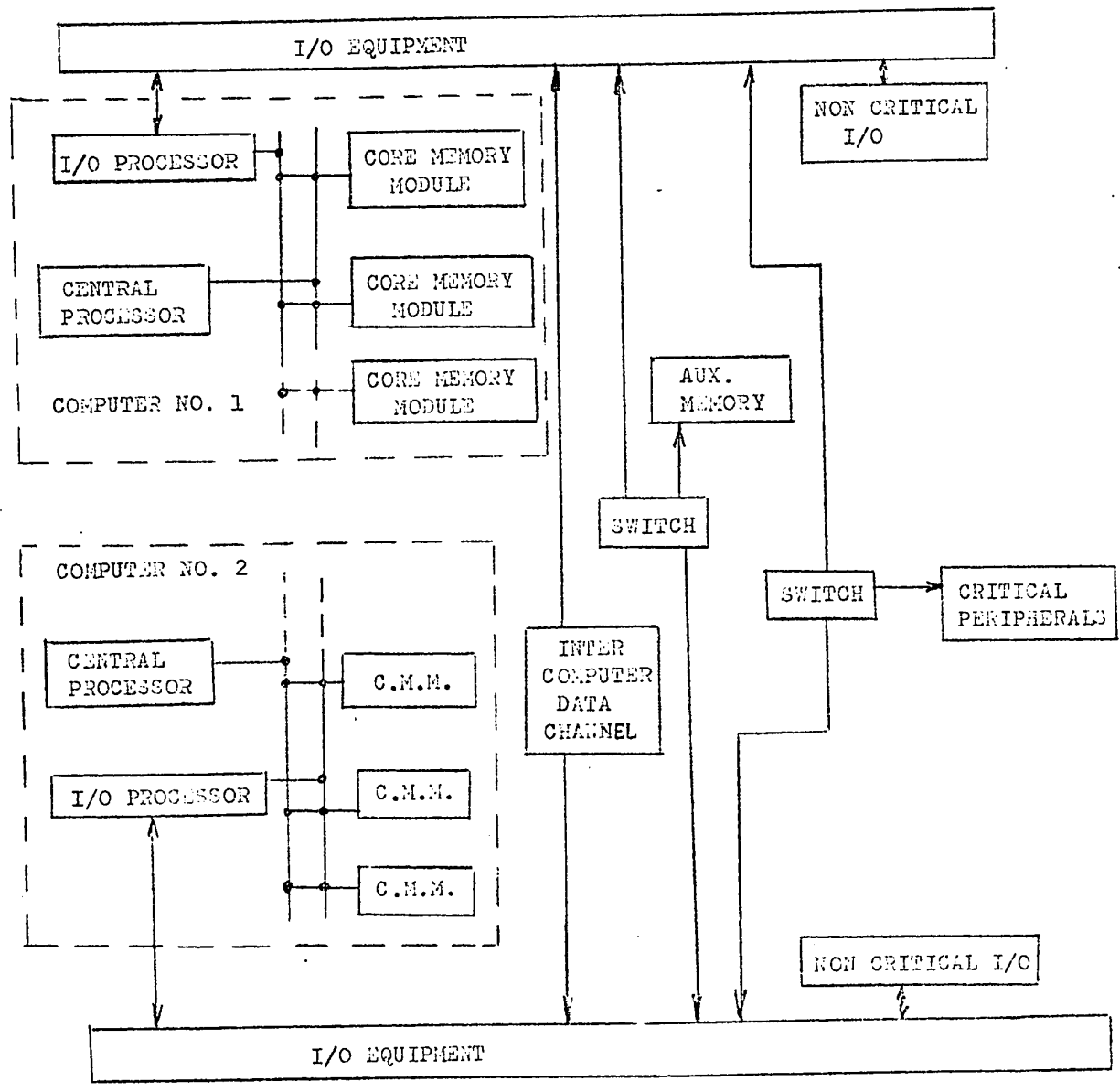

Fig. 3.6 Multicomputer Block Diagram.

In this system, each processor performs its assigned tasks more or less independently from the other.

The two processors are not entirely independent, because each one periodically tests the other by means of the interprocessor interrupts and checks the results of these tests. If a failure is found in one of the processors, remedial action is taken.

Switching must be provided for those peripheral devices that are to be accessible to either processor. In case of failure of one processor, the other must switch to its I/O those peripheral devices necessary for performing its tasks.

In this case, a single processor operates, while the other undergoes repairs.

3.3.2 Multiprocessor System

A multiprocessor system consists of two or more CPU's and at least one I/O processor, all of which have direct access to a common memory. Fig. 3.7 shows a multiprocessor system.

3.3.3 Comparison between Multicomputer and Multiprocessor.

Here are the salient advantages and disadvantages of the two configurations:

- 1- The multiprocessor recovers from failure more rapidly than the multicomputer.
- 2- The multiprocessor is more expensive than the multicomputer.
- 3- Hardware and software applicable to multicomputer organisation are more readily available than those for multiprocessor.

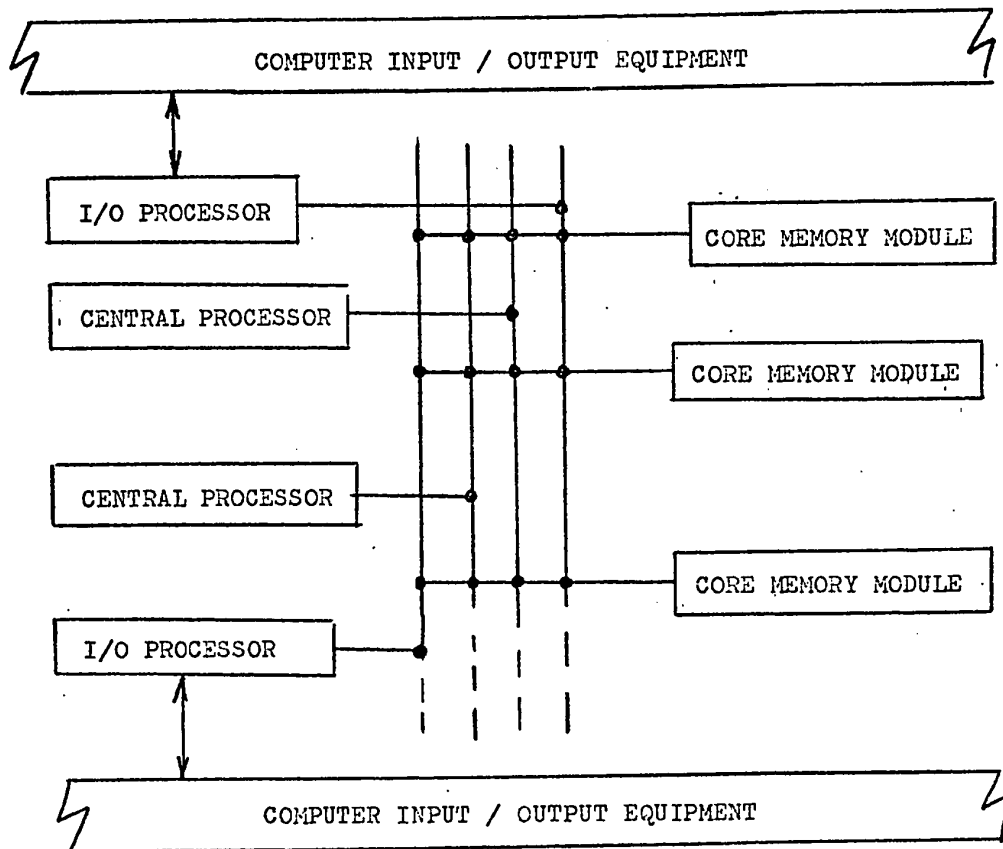

Fig.3.7 Multiprocessor Block Diagram.

- 4- The multiprocessor is expandable by small components ,while the multicomputer tends to be expandable in larger units.
- 5- Errors in results are more easily traceable to specific component failure in a multicomputer, than in a multiprocessor.

3.3.4 Standard Processor Peripherals

To minimize the cost of interfacing with processor, the following standard peripherals should be used:

- 1- Auxiliary memory units .: should be either drums or disk files. This approach will minimize access time and thus will enable minimization of core memory capacity by allowing much of the software to be stored in auxiliary memory units ready for transfer to an overlay section of core on demand.
 - 2- Magnetic Tape Units. These tapes are used for logging of dispatching data required in power flow analysis, and also for scheduling and forecasting data.
 - 3- Printers . Requirements for hard copy records for use by operating personnel dictate a number of printers of varying capacities. Both impact and electrostatic printers are used.
 - 4- Card punch / readers . Used mainly for programming functions.
 - 5- CRT display and Associated Control and Display Panel.
- These will be discussed in detail in section 3.4

3.4 Information Display and Operator Control Console [6]

3.4.1 Introduction

In all areas of the Dispatching Center Operation, the human operator needs information that his unaided senses cannot supply.

To overcome this limitation, man-machine communication devices such as CRT display, mimic boards, illuminated indicators, mechanical displays, audio and visual alarms, status indicators and input communications -such as alphanumeric keyboards-, are required to gather the needed information and to translate it into a form that humans can easily perceive, understand and act upon.

The basic requirement of the man-machine communications equipment within the dispatching center is to provide dispatching personnel with adequate real-time information on the actual status of the power system, in both normal and emergency situations.

The display equipment can be grouped into 4 classes:

- a) Group Display, such as Mimic Board, showing the gross power system to all personnel in the dispatching room. This group display will be updated in near-real-time, using data changes rather than a complete update of all information.
- b) CRT (Cathodic Ray Tube) provides more detailed information to the dispatchers. This display provides near-real-time data to help dispatchers evaluate conditions and make decisions for the execution of assigned responsibilities.
- c) Annunciator lights and Digital displays will also be used to provide detailed information, normally requiring a continuous display.

d) Analog recorders, Digital indicators and Hard Copy devices, are auxiliary equipments in Dispatching Centers.

All information retrieval and data entry is made through an operator console located in front of each operator.

For large quantity of information, normal computer peripherals devices (card readers, card punches, tapes, etc.) are used.

The CRT also is contained in the control console and is used by the operator for data or orders entry.

All display devices mentioned earlier are now discussed in the following sections.

3.4.2 Group Display (Mimic Board)

The group display is defined as a one-line schematic diagram of a complete electric power system, which can be viewed and used simultaneously by more than one person. The group display provides a general view of the main transmission network and associated generating stations. Discrete items such as circuit breaker status and analog values such as volts, watts, vars, frequency of some important lines and stations, are displayed also on the mimic board.

The group display is used mainly as guide for operators to return the system to its normal state after a system disturbance.

The group display is formed by square colour tile blocks as basic elements. This approach makes modification and expansion quite simple. Usually, the mimic board displays a substation as a block and it doesn't show its detailed diagram.

3.4.3 CRT Displays

CRT display provides greatly detailed information, not available at the mimic board. CRTs are installed at the operator control console. The CRT displays the electrical diagram of each substation. All the informations to be displayed on the CRT monitor will be provided to the display generator by the computer, through its I/O units. The display generator then performs decoding, assignment to appropriate consoles and CRT, and generation of corresponding video signals to enable the CRT monitor to present alphanumeric and graphic displays.

3.4.4 Digital Displays

Dynamically updated digital displays provide near-real-time continuous quantitative information for specific parameters. System frequency is the most important parameter; less important parameters are voltages at various nodes.

3.4.5 Operator Console Equipment

Console equipment must be specified to provide operational capability in the following four categories of man-machine communication:

- a- Retrieval of computer-based information for selective display.
- b- Control of computer-based software packages.
- c- Control of display and other peripheral equipment.
- d- Entry of both numeric and alphanumeric data.

Fig. 3.8, 3.9, 3.10 give some idea about the equipment discussed so far.

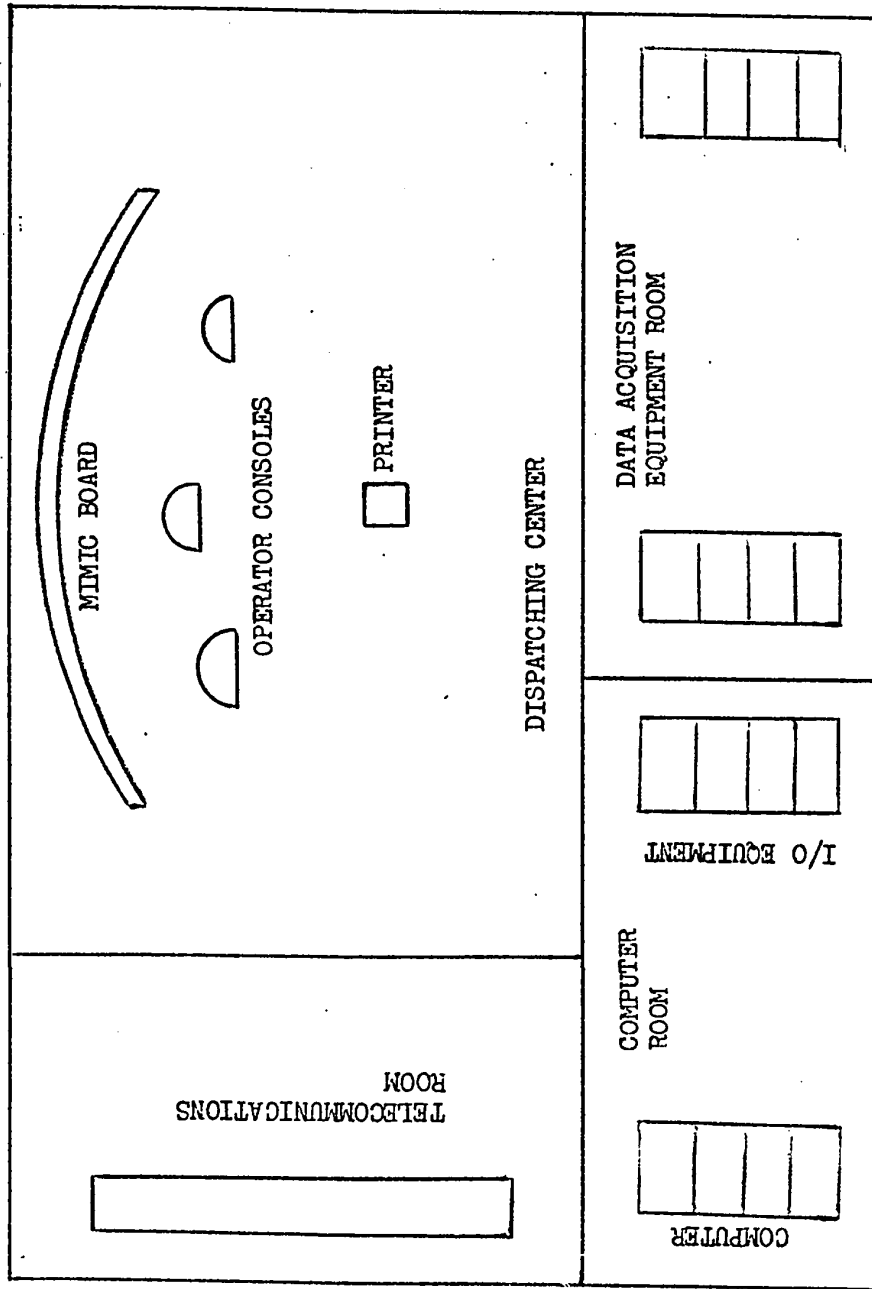

Fig. 3.8 General Equipment Layout in a Dispatching Center

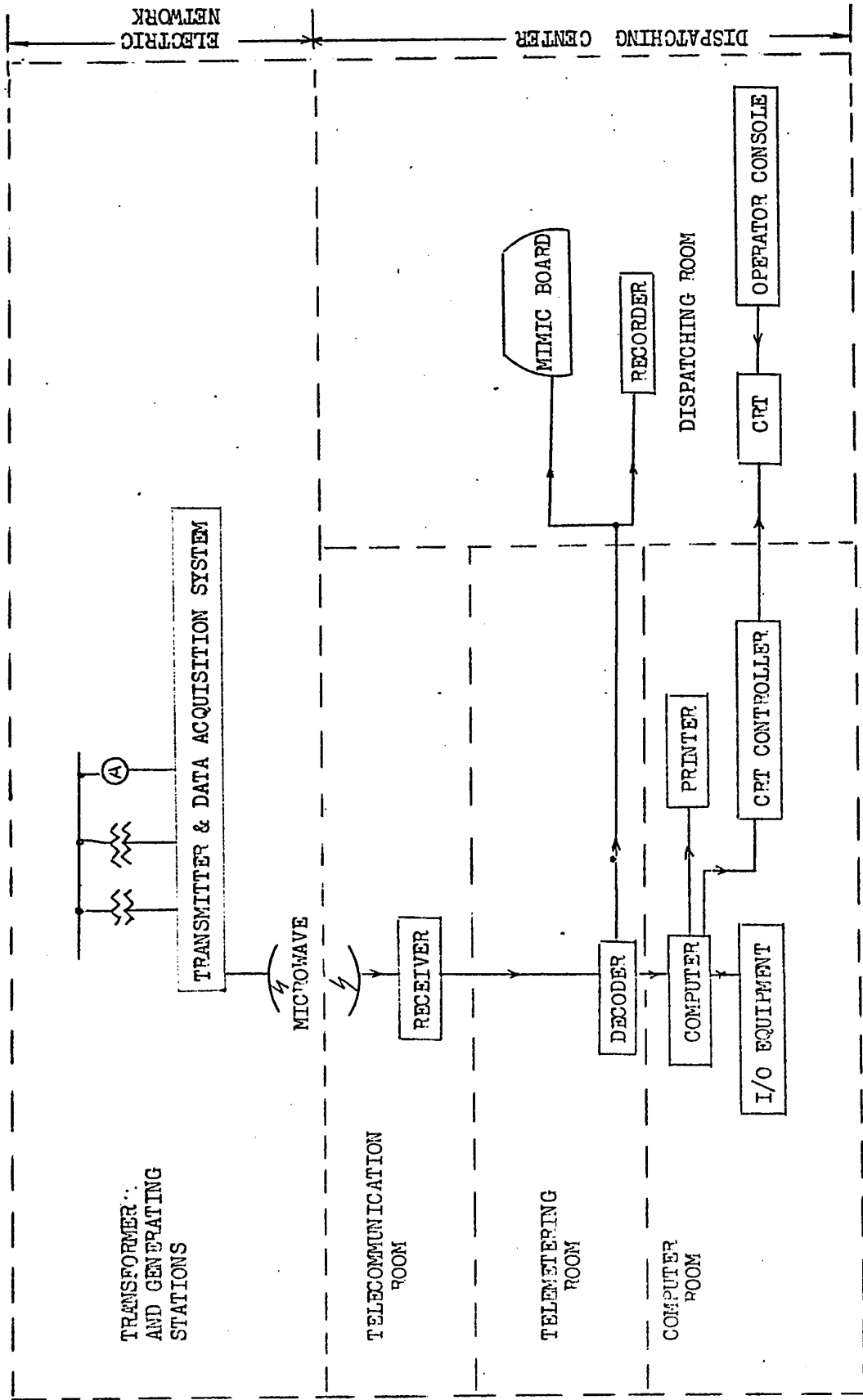

Fig. 3.9 Block Diagram of Data Flow and Equipment Layout in Dispatching Center

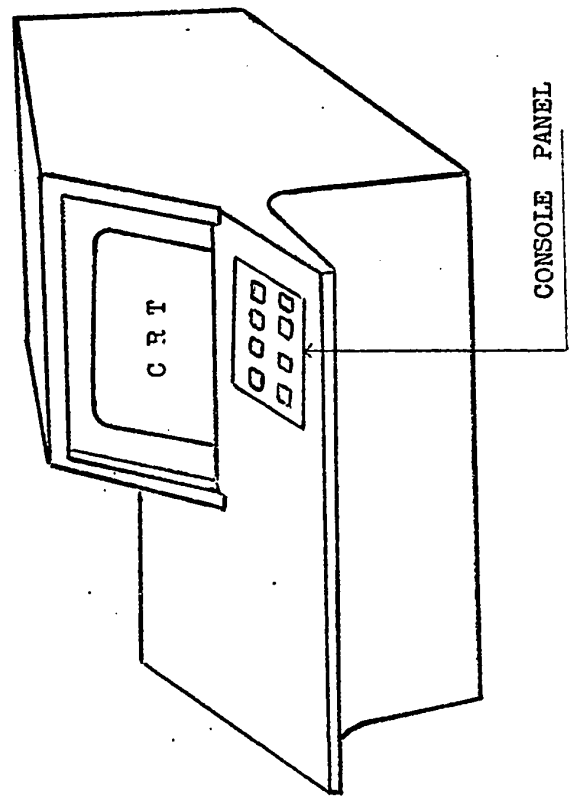

Fig. 3.10 Operator Console

CHAPTER 4BASIC DISPATCHING COMPUTER SOFTWARE CONCEPTS [6]

A brief discussion of the dispatching center software concepts from the point of view of power control requirements, will follow.

4.1 Operating Systems (O.S.)

The operating systems supplied by the computer manufacturers are designed primarily to increase the operational efficiency of the hardware. As such, the O.S. is supposed to do everything the hardware does not do. The O.S. also eases the burden of programming, by selecting common requirements of all programs and offering these services (I/O , file creation, operator intervention, subroutine calls, etc.) through sets of control cards or statements. Most O.S. are designed for a 'general purpose' computer, and to be applied in power systems, the control engineer must blend his hardware/software requirements to have maximum efficiency from the computer.

4.2 Batch Processing

In this type of data processing, the processing time is not critical i.e the results are not needed immediately. Most data processing installations are of this type.

4.3 Real-Time Processing

This type of data processing accepts jobs (programs) as permanently scheduled, or by external interrupts. Each event causes the Central Processing Unit (CPU) jump to a specific address in memory, rather than the

next sequential normal instruction. At this location is an appropriate routine to process the event or to transfer it to another appropriate routine. The normal next sequential instruction must be saved, along with appropriate registers, to allow return to the program that was interrupted. When the interrupted program regains control, it proceeds as if it had never been disturbed. All power control systems must take advantage of this computer capability to react to critical events which require split second response time.

4.4 Multicomputers and Multiprocessors

A multicomputer system consists of two or more computers assigned to a single problem to insure reliable operation by virtue of redundancy.

A multiprocessor system contains two or more CPU's which share common memory and I/O facilities. The common memory can be addressed by all CPU's. This is already discussed in 3.3.

4.5 Multiprogramming and Time Sharing

Since the speed of I/O equipment is much lower than the CPU processing speed, many programs can be in the memory at the same time and share the facilities. Such a technique, which makes use of time sharing facilities, is known as "multiprogramming".

4.6 Languages

1- Machine oriented languages : are usually an assembler programming system consisting of a language and a translator. The assembly process (translation) is only a one-to-one translation, meaning that

a single line of coding in the source program will result in the generation of single machine language instruction.

2- Problem oriented languages, or compilers, usually translate many machine language instructions from a single statement in the source program. The most popular and easy to use are: FORTRAN, COBOL and ALGOL.

4.7 Off-line and On-line Diagnostics Programs

These are programs required to test, on-line or off-line, CPU, memory, all peripherals and all channels both individually and in system operating modes.

4.8 Utilities Programs and Library

The utilities programs consist of all I/O handling programs, debugging, housekeeping programs designed mainly to ease the programmer's task.

The library are subroutines that can be called by compilers or assemblers, macro-instructions or control cards. All mathematical subroutines (Arc-tan, sin, etc.) are stored in the library.

4.9 Real-time Computation

4.9.1 Foreground and Background. For a real-time control system, certain programs are required to be done periodically on conditions, on singular events, or on authorized operator demand.

For these programs, a duty cycle is defined as an optimum time which assures that everything that has to be done will be done, with spare time remaining. The duty cycle of an electric system is several seconds. All programs which are executed during the duty cycle are

called Foreground Programs; other programs executed after all foreground processing is completed are Background Programs.

4.9.2 The real-Time Control Software. The Executive (or supervisor, or monitor) program allocates central processor time on a priority basis. The efficiency of the executive is important because it is executed more than any other program in the machine. The real-time supervisor consists of 4 basic areas of responsibility: real-time scheduling, priority management, real-time diagnostics and system element file control.

Fig. 4.1 shows a functional diagram of a real-time supervisor.

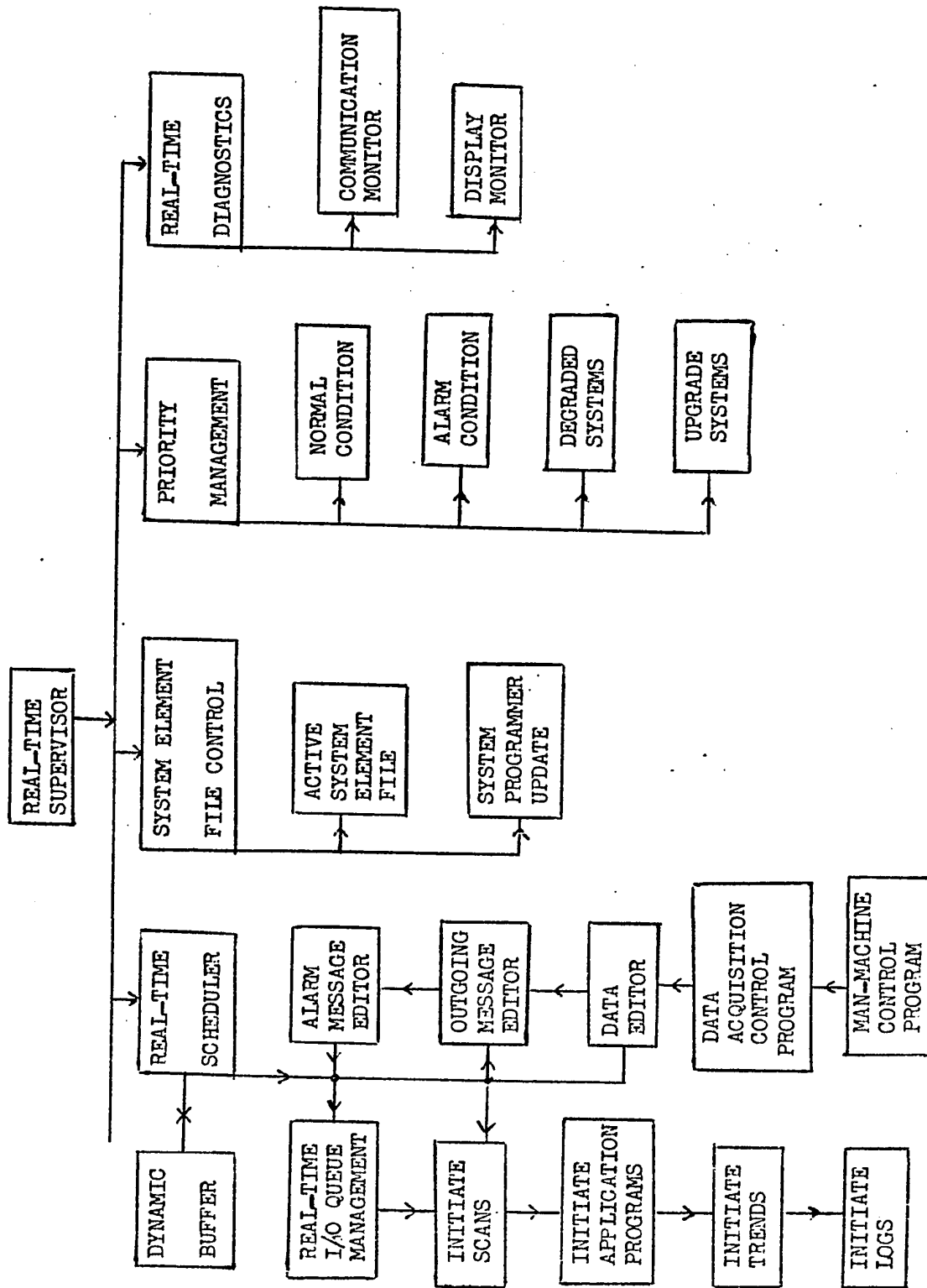

Fig. 4.1. Real-time Supervisor Functional Flow

CHAPTER 5

POWER SYSTEM APPLICATION PROGRAMS USED IN A DISPATCHING CENTER.

5.1 Power System Problems

All power system problems can be solved by using the general method outlined in fig. 5.1

5.2 Power System Problems Classification

In fig. 5.2, a set of power system problems is shown, with methods of solution and the time classification of each problem.

5.3 General Description of Power System Application Programs

Fig. 5.3 outlines the organization of application programs frequently used in a dispatching control center.

The relation between different power system application programs and mathematical methods is shown in fig. 5.4

Depending on the complexity of each power system, one or more application programs will be processed by the Dispatching Center Computers.

The following list gives a brief description of each application program:

1- Power Flow or Load Flow Program

This program provides for the computation of the main grid voltages and angles at the busses, and the real and reactive power in the lines.

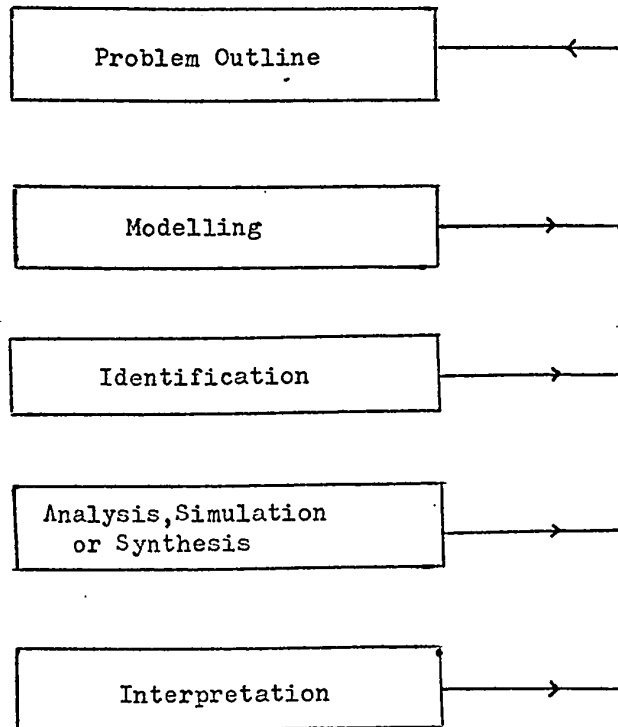

Fig. 5.1 Data Processing of Power System

Time in Sec.	Domain	Power system Problems	Solutions
10,000	↑	Optimization of power System operation (Economic Dispatch, etc.)	Optimization techniques: linear, non-linear, dynamic
1,000		State Estimation	Least Square Methods Non-linear Optimization
100	Steady State ↕	Load Flow	Newton-Raphson method Non-linear Optimization Gauss, Fletcher-Powell methods
10		Oscillations of frequency Reactive and Active Power (IFC and Var-Voltage Control)	State Variables $\dot{x} = A_x + B_u$
1		Dynamic Surtensions	Solution Methods: a) Numerical Integration b) Eigenvalues c) Curve of Frequency vs Time
0.1	Transient ↓	Synchronous Machines Stability (Slow Transient)	
0.01		Short circuits in electrical machines and networks (transmission lines): Medium-Fast Transients.	Symmetrical Components Transformation Matrix Calculation Graph Theory
		Overvoltages caused by operation switching and lightening (ultra-fast transient; surge phenomenon)	Fourier Method Travelling waves

Fig. 5.2 Classification of Power System Problems vs Time.

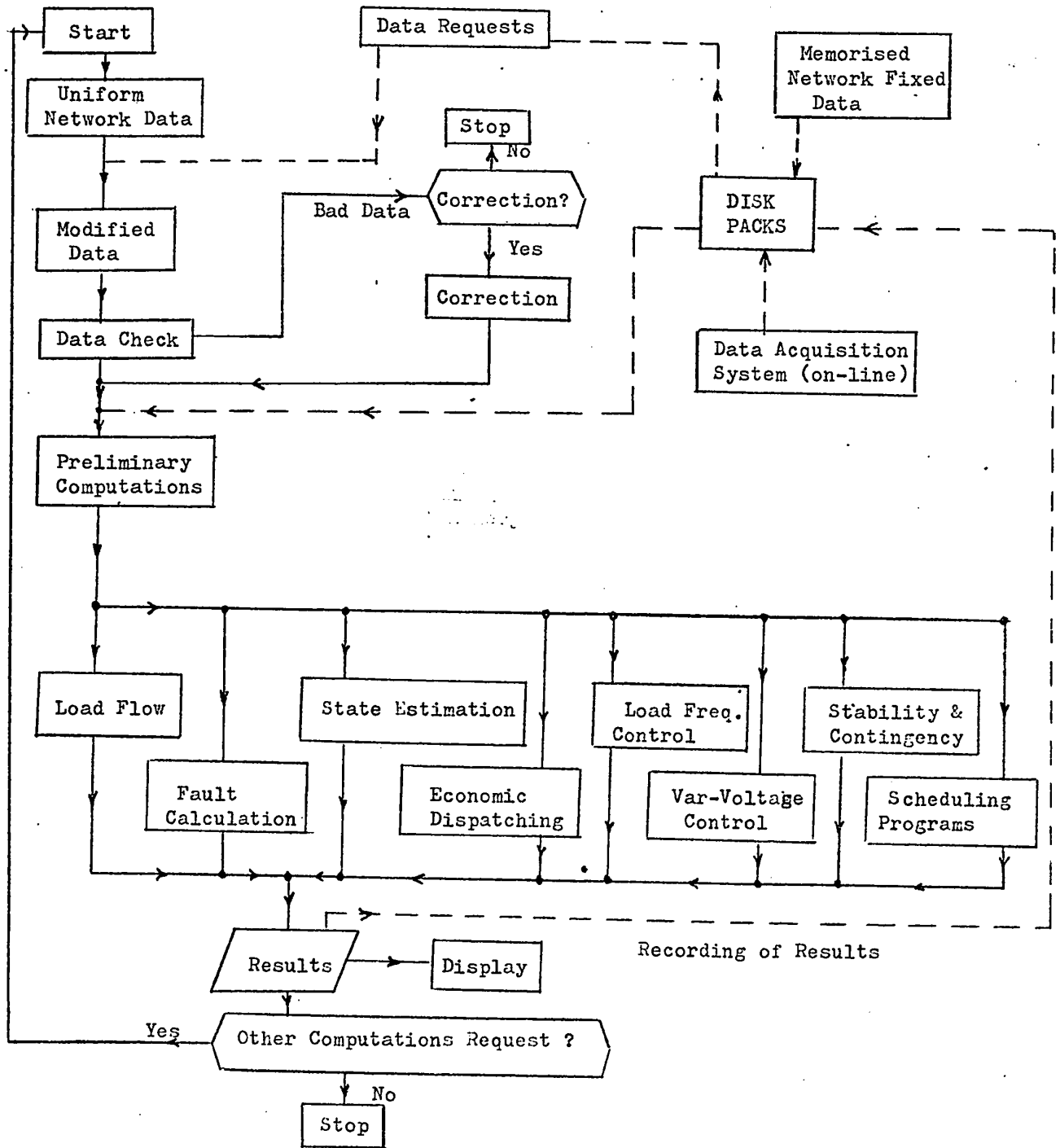

Fig.5.3 General Flowchart of Power System Operation Software.

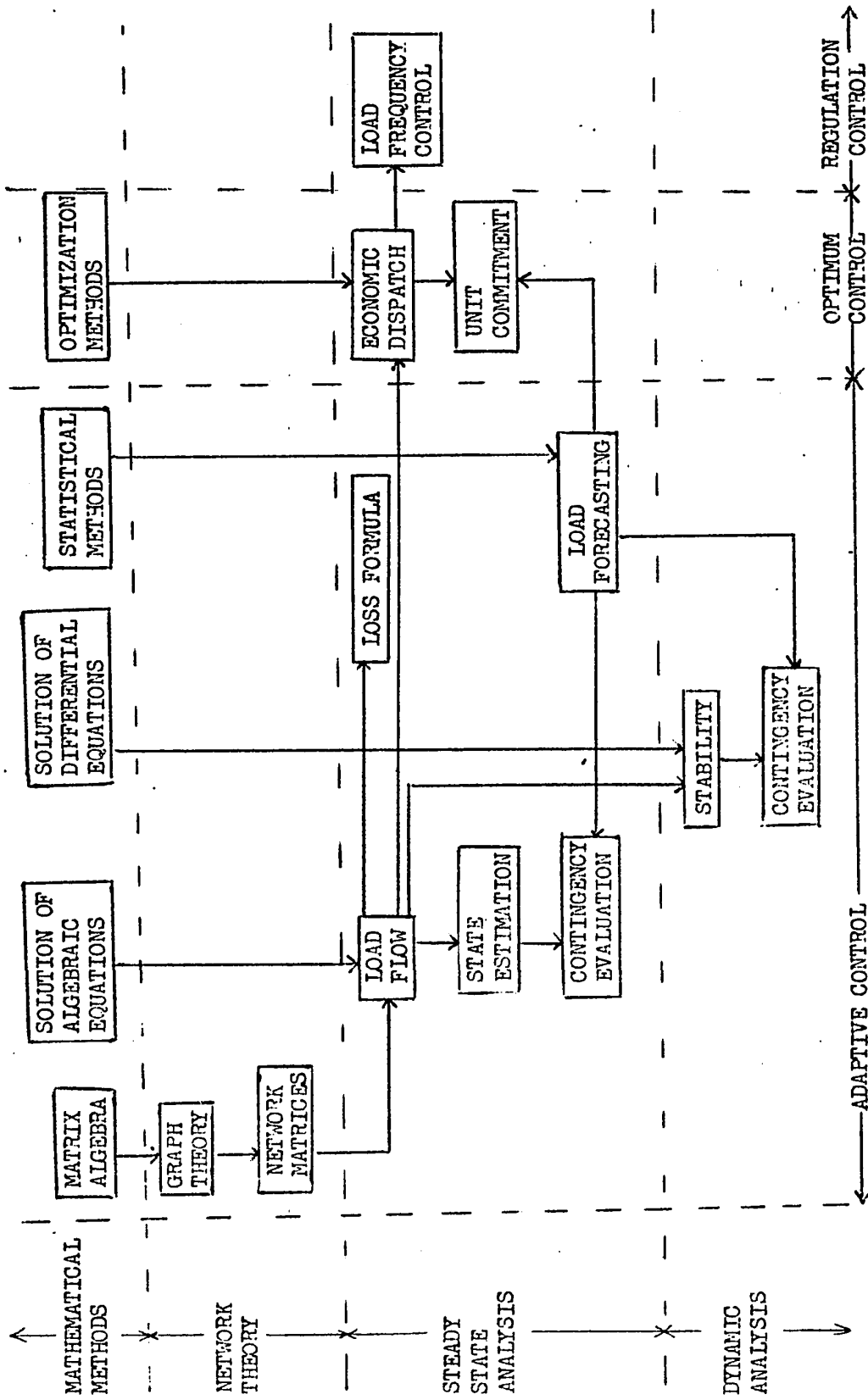

Fig. 5.4 Relation between Power System Programs and Mathematical Theory

Computations are based on either real-time or predicted future time data.

2- State Estimator Program

This program provides for the computation of the best estimate of present time bus voltage and phase angles ,and real and reactive power in the lines. The State Program is executed every 3 seconds until the computations have reached a steady-state condition..Then,it should not be necessary to run it again until there is a significant change in the state of the system.

3- Economic Dispatch and Unit Commitment

This program provides for the computation of the optimal cost of each generated KWH by determining the location and the number of running and stopping generators. This optimization must be realized without endangering the power system stability. Generating electricity at the lowest cost,is referred to as "economic dispatch".

How to realize this minimum cost by an optimal choice of the number of generators at various power plants,is referred to as "unit commitment".

4- Watt,Frequency and Var,Voltage Control Program

Once the amount of electricity to be generated has been determined by Economic dispatch program,the Watt,Frequency Control Program is called upon. This program supervises the amount of watts to be produced by each power plant and it also controls the frequency of the power system. Voltage constraints at each node must be respected by controlling the reactive power at each generator.

5- Power System Stability Program

This program provides for the computation of the critical clearing time, during wich time the breakers must isolate the faulted line from the system. This computation is performed after sudden disturbances

(faults, line switching, sudden application or removal of loads) have occurred.

6- Contingency Analysis Program

This program provides for the computation of the state of the power system. Emergency and vulnerable states are accounted for by this program. Then alarms are generated, to alert the operators who can take appropriate corrective actions.

All these above-mentioned application programs will be discussed briefly in chapters 6 to 12.

CHAPTER 6

LOAD FLOW

6.1 Introduction

A load flow study is the determination of : voltage, power, current, power factor and reactive power at various points in an electric network under existing or contemplated conditions of normal operation.

The load flow study is used in :

- 1- Future planning or addition of a section to an existing system.
- 2- Dispatching of power: the generation of power must equal the demand at each moment. This is the economic dispatch which we will consider later.
- 3- Avoidance of overloading: each transmission link can only carry a specific amount of power. Care must be taken to avoid overloading.
- 4- Scheduling of proper reactive power: it is necessary to keep voltage levels of certain busses at rather close tolerances.
- 5- Supervising the tie-line between neighbouring systems.
- 6- Preventing system outages by proper prefault load flow strategies.

The formulation of a load flow problem consists of the following stages:

- a) Construction of system model by using equivalent circuits of generators, transformers, and power lines, as discussed in chapter 2.
- b) A specification of power and voltage constraints that must apply to various buses of the network.

- c) Numerical computation of load flow equations subject to the above constraints.
- d) Computation of the actual load flow in all transmission lines, when all bus voltages have been determined.

6.2 Bus Classification

Four variables: active power P_1 , reactive power Q_1 , voltage V and phase angle δ are important for each node.

Depending on the number of specified variables and the number of unknown variables, there are four kinds of buses:

- 1- Swing or slack generator bus (also called Reference bus): specify V and δ . The swing generator is usually equipped with fast speed governor, and is the first to take up loads. See fig. 6.1 a
- 2- Voltage generator bus: specify $|V|$ and P ; see fig. 6.1 b
This is also known as "voltage control bus" because its voltage can be controlled.
- 3- Load bus: specify P and Q . See fig. 6.1 c
- 4- No load, no generation bus: $P_L = Q_L = 0$. See fig. 6.1 d

6.3 Load Flow Equation Classification

A number of load flow equations, linear or non-linear, was previously developed in sections 2.2 and 2.5 :

- a) Current equation at node can be written as:

$$I_k = Y_{k1} V_1 + Y_{k2} V_2 + \dots + Y_{kn} V_n$$

This has been a popular approach and yields a set of linear equations.

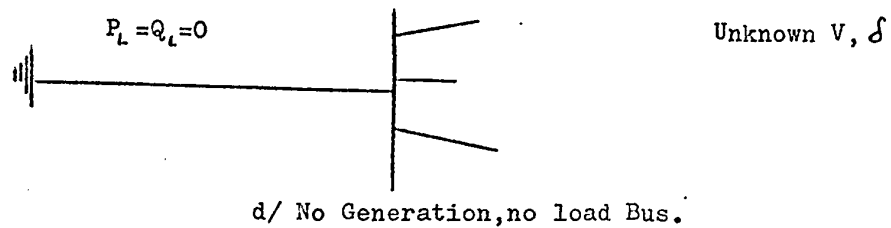
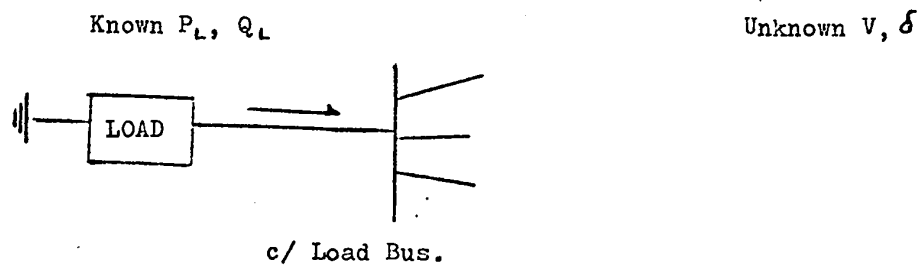
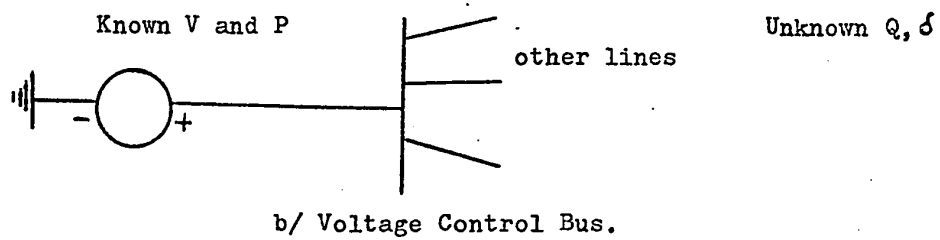
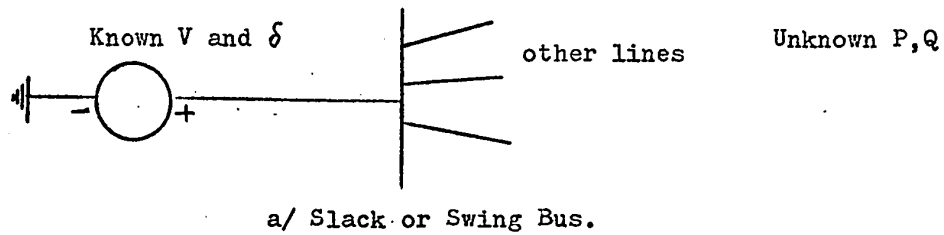

Fig. 6.1 Representation of various node types.

b) Voltage equation for k loops can be written as :

$$E_k = Z_{k1} I_1 + Z_{k2} I_2 + \dots + Z_{kn} I_n$$

Again, this yields a set of linear equations.

c) Complex power equation :

$$P_i + j Q_i = V I^*$$

This equation denotes the power flowing to or from bus i and is a non-linear set of equations.

The solution of a set of non-linear equations can be reached by means of numerical methods, using:

- the Gauss iterative method
- the Gauss-Seidel method
- the Newton-Raphson method

All these methods use either Y_{bus} or Z_{bus} as frame of reference.

Detailed development of the above mentioned methods can be found in ref. 3, Chap. 8.

6.4 Loading Equations for Slack Buses [3]

The real and the reactive power at any bus p is :

$$P_p - jQ_p = E_p^* I_p \quad (6.1)$$

and the current is :

$$I_p = (P_p - jQ_p) / E_p^*$$

where I_p is positive when flowing into the system. If the shunt elements to ground Y_p are included in the network equation, then equation (6.1)

is the total current at bus.

On the other hand, if the shunt elements are not included, the total current at bus p is :

$$I_p = (P_p - jQ_p) / E_p^* - y_p E_p \quad (6.2)$$

where y_p is the total shunt admittance at the bus, and $y_p E_p$ is the shunt current flowing from bus p to ground.

6.5 Line flow equations [3]

After the iterative solution of bus voltage is completed, line flows can be calculated. The current at bus p in the line connecting bus p to q is :

$$i_{pq} = (E_p - E_q) y_{pq} + E_p (y'_{pq}) / 2$$

where y_{pq} = line admittance

y'_{pq} = total line charging admittance

$E_p y'_{pq} / 2$ = current contribution at bus p due to line charging.

The power flow is :

$$P_{pq} - jQ_{pq} = E_p^* i_{pq}$$

or :

$$P_{pq} - jQ_{pq} = E_p^* (E_p - E_q) y_{pq} + E_p^* E_p y'_{pq} / 2 \quad (6.3)$$

Similarly, at bus q the power flow from q to p is :

$$P_{qp} - jQ_{qp} = E_q^* (E_q - E_p) y_{qp} + E_q^* E_q y'_{qp} / 2 \quad (6.4)$$

A general arrangement of a typical load flow problem in a power system application programs package is shown in fig. 6.2 .

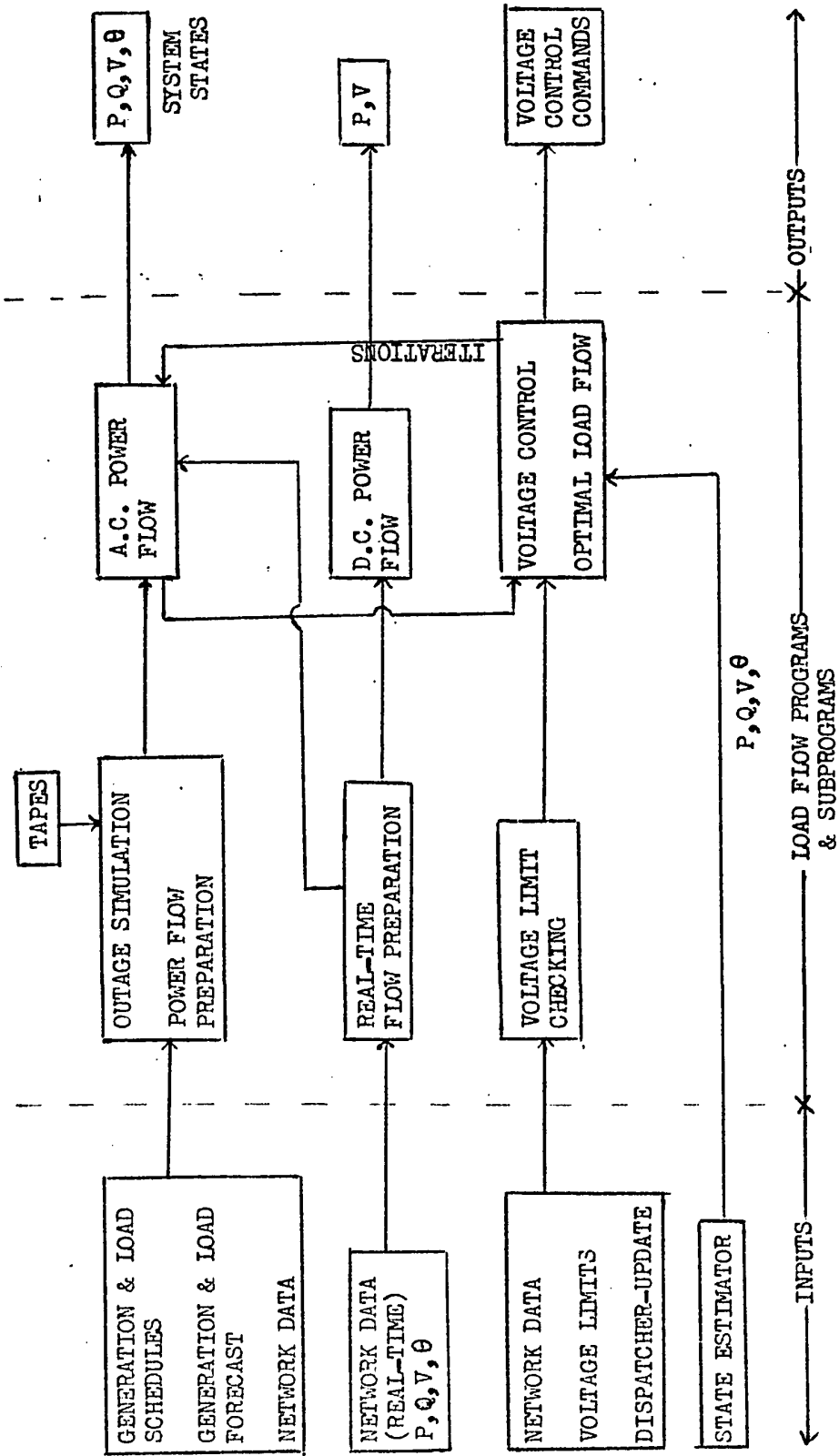

Fig. 6.2 General Arrangement of a Load Flow Program

CHAPTER 7STATE ESTIMATION PROGRAM [7]7.1 Introduction

State estimation is a digital processing scheme which provides a real-time data base for many of the dispatching center control functions in a power system.

The Estimator processes the imperfect information available and produces the best possible estimate of the true state of a given system.

The State Estimator computes the state of a system from the following three sources of information:

- 1- Measurements of system variables.
- 2- The mathematical model of the system and its instrumentation.
- 3- Prior knowledge of various system inputs and outputs, referred to as "pseudomeasurements".

The output of the state estimator approaches the true state of the system. Discrepancies between the true and estimated states are due to the following factors:

- a) Noise in instruments and telemetry channels
- b) Incomplete instrumentation, in the sense that many variables are not measured at all
- c) Delayed measurements that reflect a prior system state
- d) Erroneous pseudomeasurements
- e) Innacurate network parameters

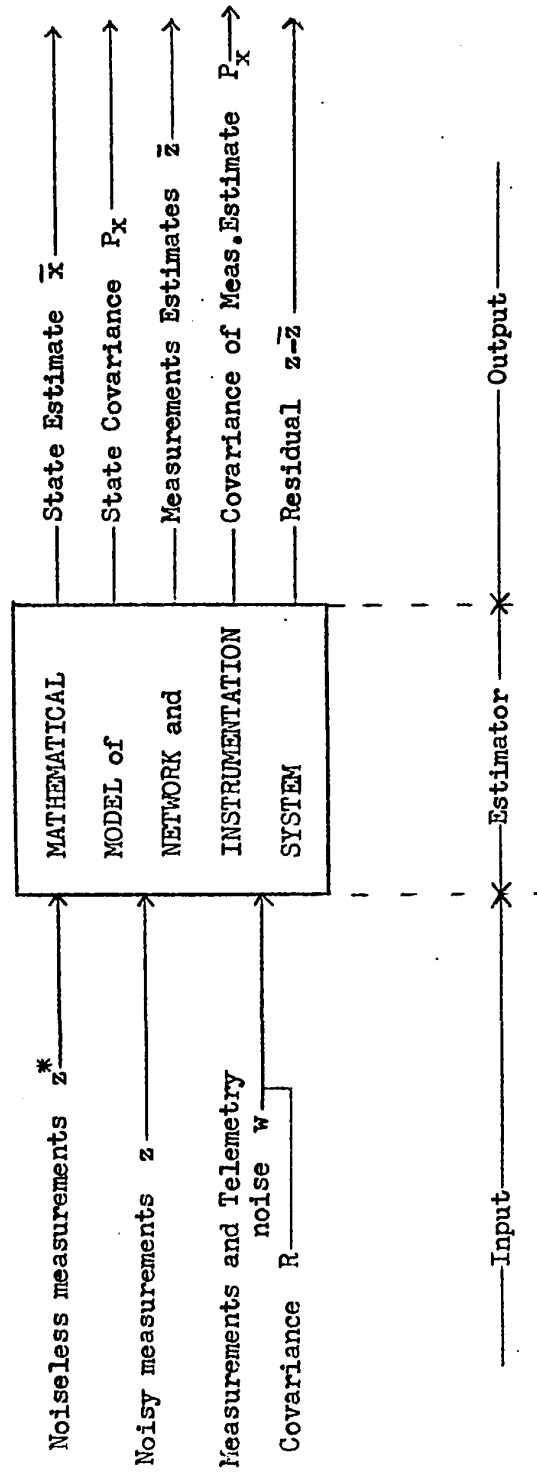

Fig. 7.1 Estimator Inputs and Outputs

7.2 State Estimator Design

It is customary to define a scalar cost function as a function that increases with the estimation error. An Estimator that minimizes this cost function is optimal. The optimal Estimator not only generates a State Estimate, but also the covariance or "error" associated with it. The covariance matrix predicts the magnitude of the estimation error and hence provides a measure of confidence of the estimated state. The predicted and the actual estimation errors should be of the same order of magnitude. Significant differences indicate that a major change, such as a fault, has occurred in the system or in the instrumentation and an alarm signal can be given.

7.3 Power System State Estimator: Inputs and Outputs

In a power system, the state variables are: the voltage V and the phase angle θ at the nodes. Other variables such as the real power P and the reactive power Q are obtained by measurements or pseudomeasurements. Fig. 7.1 shows the typical inputs and outputs of an Estimator, where:

z = noisy measurements or pseudomeasurements V, P, Q, θ etc.

z^* = noiseless measurements and pseudomeasurements as would be obtained from a perfect sensor.

w = additive sensor and telemetry noise.

\bar{x} = state estimate of V and θ at each node.

\bar{z} = processed measurements and pseudomeasurements.

$z - \bar{z}$ = residual or difference between actual and estimated measurements ;
the residual is used to detect system anomalies.

R = noise covariance matrix

P_x = state covariance matrix

P_z = covariance matrix of the estimated measurements \bar{z}

7.4. Elements of an Estimator

The basic configuration of an Estimator can be broken down into five functional groups, as follows:

- 1- Measurements and telemetry
- 2- Input-data storage and display (pseudomeasurements specification; measurements accuracy specification; network data; short term forecast)
- 3- Estimate and covariance calculation (measurement processing control; power flow program; power flow covariance calculation; sequential processor for measurements)
- 4- Output-data storage and display
- 5- Dispatching center

Fig . 7.2 shows the organization of the State Estimator.

7.5 Explanation of the Estimator Blocks

Block 1. Telemetry System

This is the data acquisition system, which receives all measurements from various parts of the network and transmits them to the computer.

Block 2. Input-Data Storage and Display

Here all network data: configuration, parameters, telemetry accuracy and pseudomeasurements are gathered and stored or displayed if necessary.

Block 3. Pseudomeasurements Specification

Pseudomeasurements are not available from the data acquisition system and could be obtained from historical data, load forecast, generation schedules, operator experience, etc. They need not to be very accurate, but they should be within an order of magnitude of the true value of the quantity they represent.

Block 4. Measurements Accuracy Specification

Obtained from the characteristics of the hardware in the measurements and telemetry system.

Block 5. Network Data

Where data and parameters of the network are obtained.

Block 6. Short Term Forecast

Where data concerning load are stored.

Block 7. Measurements Processing Control

This block performs the coordination and scheduling of state estimator calculations.

Block 8. Sequential Processor for Measurements

This block takes one measurement at a time from a set of z and updates the state estimate \bar{x} and its covariance P_x .

Block 9. Power Flow Program

Computes an initial estimate x_0 based on the n measurements in z .

Block 10. Power Flow Covariance Calculation

Provides an estimate of the covariance.

Block 11. Output-Data Storage and Display

Gives the most recently updated values of the state variables.

Block 12. Dispatching Center

The operator in the Dispatching Center can update some outputs of data by giving order to the measurements processing control.

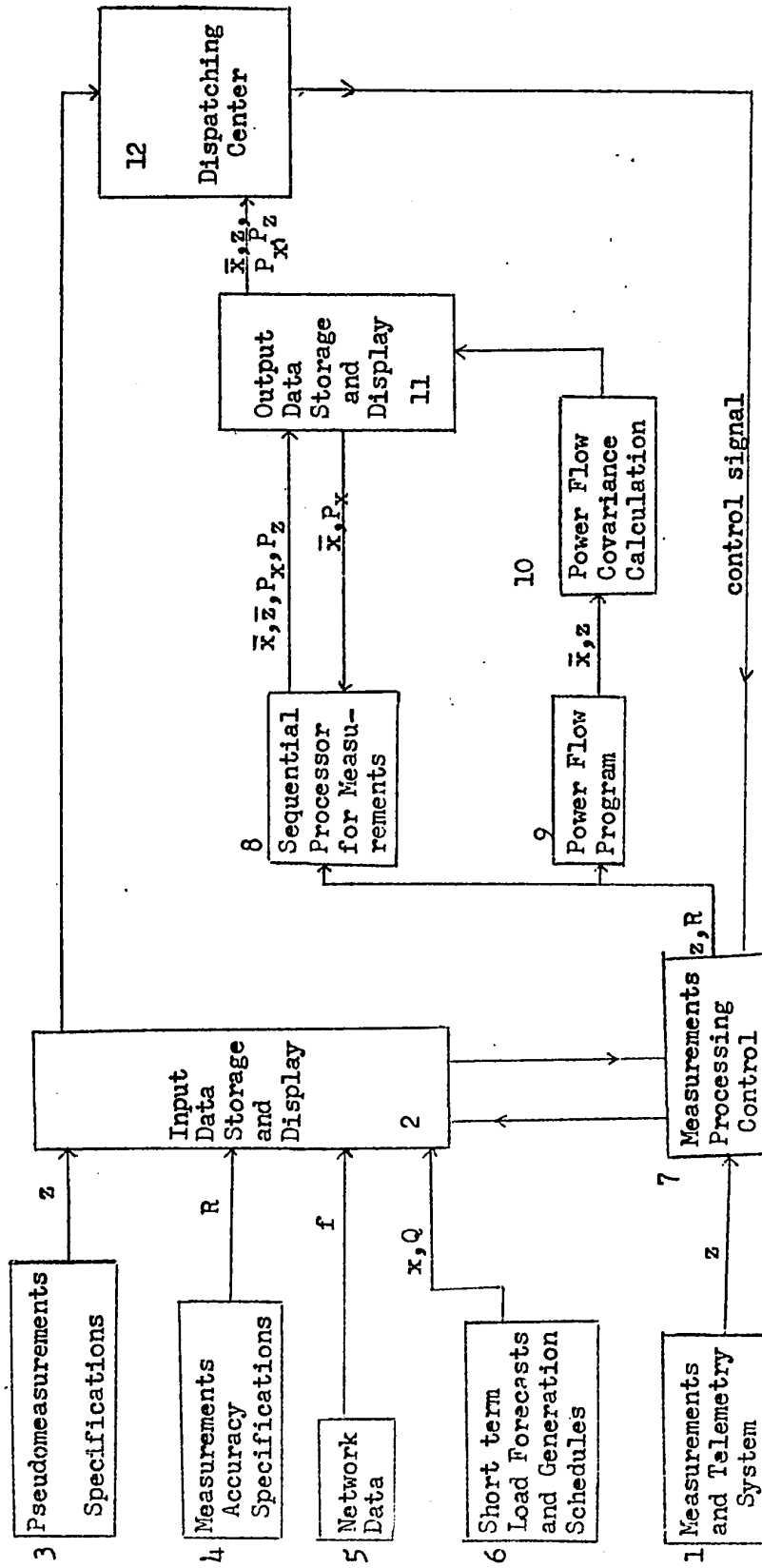

Fig. 7.2 On-line State Estimator Block Diagram

7.6 Applications of the State Estimator

a) On-line:

- 1- Permits improvements in system security by providing a real-time data base for on-line security analysis, anomaly detection, fault diagnosis, and display functions.
- 2- Facilitates the implementation of dispatching functions by minimizing the requirements for additional costly sensing and telemetry hardware.

b) Off-line application:

Planning and design of the information system, to obtain the data required for the dispatching center in the most economical manner.

CHAPTER 8

ECONOMIC DISPATCH

8.1 Introduction

The economic dispatch of a power system is concerned with the optimization of power generation to satisfy power load, with a given combination of generators running.

This optimization is necessary to produce the electricity at the lowest cost without endangering the system power constraints.

These constraints are: the capacity of individual generators, the voltage level at each bus and the reserve requirements for system security.

When a number of generating stations are not connected by long lines of transmission, the line losses can be neglected, but the losses must be taken into account in case of long lines.

8.2 Optimum Generator Allocation with line losses neglected: intuitive approach [4]

For a thermal generator, the relation between the fuel cost and the output power is shown in fig. 8.1

The slope $\lambda = \frac{\Delta F}{\Delta p}$ is defined as the incremental cost of generation.

By plotting λ for the various outputs, we obtain the incremental cost curve shown in fig. 8.2

This curve is a measure of the cost required to produce the next increment of power.

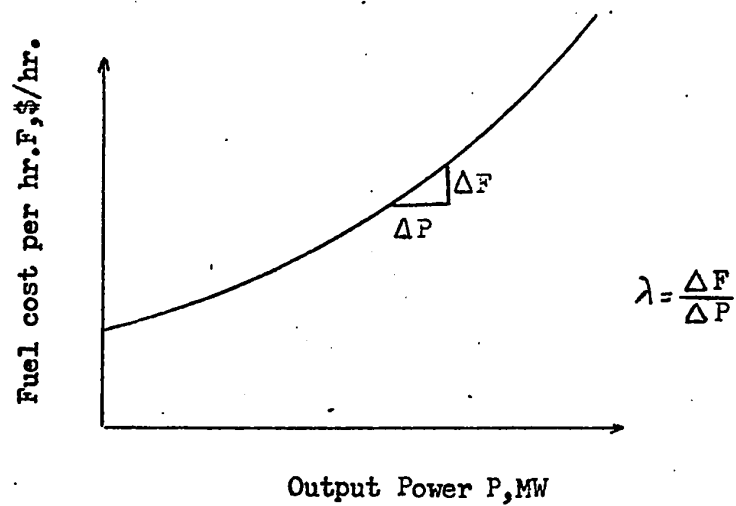

Fig. 8.1 Input-output curve with ordinate converted to \$/hr.

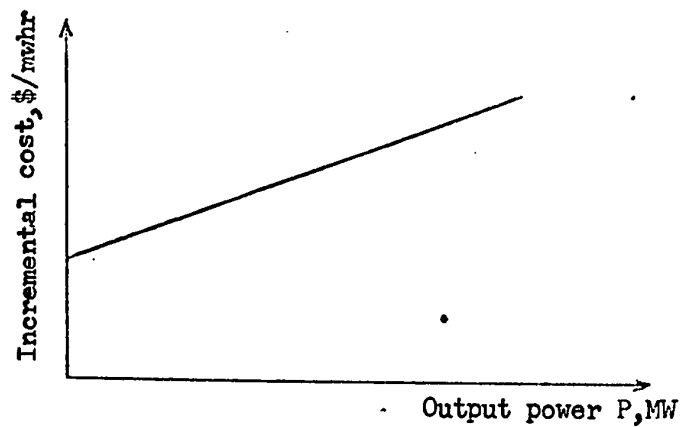

Fig. 8.2 Incremental cost curve for a generator.

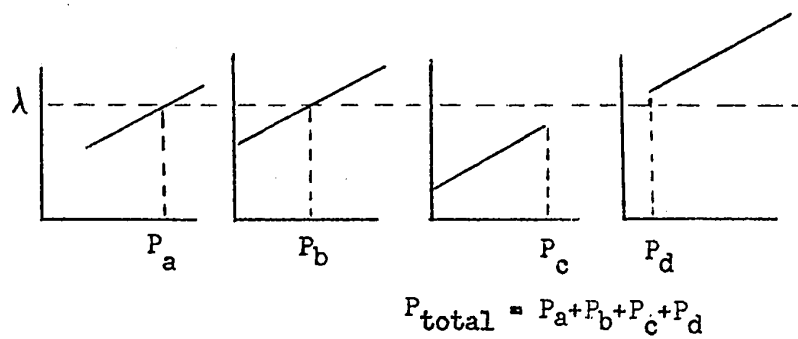

Fig. 8.3 Economic distribution of load between four generators.

Now let us assume that two or more generators within the same plant are to be operated together in the most economical manner.

The basic criterion for such an operation is that each unit operates at the same value of incremental cost or:

$$\lambda = \frac{dF_1}{dP_1} = \frac{dF_2}{dP_2} = \dots = \frac{dF_n}{dP_n} \quad (8.1)$$

This principle is illustrated in fig. 8.3

The parameter λ is well defined in thermal and nuclear stations, where the fuel cost is well known. For hydraulic stations, however, λ is undefined, since the cost of water is not clearly known, as it depends on the region and the season.

8.3 The General Economic Optimal Dispatch Problem: mathematical approach

Let F_i be the cost function of generator i ; P_i be the production and P_L the loss. Then, for n machines:

$$\begin{aligned} \text{total cost } F_T &= \sum_{i=1}^n F_i \\ \text{and total generation } P_G &= \sum_{i=1}^n P_i \end{aligned}$$

The economic dispatch problem can be fully defined as:

-to minimize total cost function F_T , subject to the following 2 constraints:

- a) Kirchoff's equation at each node: $VY = I$, as already shown in equation (2.12), where I = nodal current; V = nodal voltage; Y = total nodal admittance.

b) Loss equation: $P_L = P_G - P_D \quad (8.2)$

where : P_G = total generation ; P_D = total demands; P_L = total losses.

8.4 Minimization technique: The Lagrangian Multiplier λ

The Lagrangian multiplier can be used when the optimization problem is of the equality constrained type only.

The general problem is:

-to minimize $f(x)$, subject to constraints $h_j(x) = 0$, for $j=1,2,\dots,p$

where: $x = (x_1, x_2, x_3, \dots, x_n)$

The Lagrangian function $L(x, \lambda)$ is constructed as :

$$L(x, \lambda) = f(x) + \sum_{j=1}^p \lambda_j h_j(x) \quad (8.3)$$

whereby the original constrained problem has been transformed into an auxiliary unconstrained problem.

The minimum of L and f coincides when all $h_j = 0$.

Let's differentiate (8.3) with respect to x and λ and equate to zero:

$$\frac{\partial L}{\partial x} = \frac{\partial f(x)}{\partial x} + \sum_{j=1}^n \lambda_j \frac{\partial h_j(x)}{\partial x} = 0 \quad (8.4)$$

$$\frac{\partial L}{\partial \lambda} = h(x) = 0 \quad (8.5)$$

The solution of (8.4) and (8.5) locates the minimum of L at a point where $h(x) = 0$ and then it gives the solution to the original problem.

8.5 The Incremental Cost λ of Generators in same plant: No line losses

Let us apply Lagrangian equation to the general economic dispatch.

By forming the new function :

$$L(x, \lambda) = F_i - \lambda \left(\sum_{i=1}^n P_i - P_D \right) \quad (8.6)$$

and taking the partial derivative with respect to P_i :

$$\frac{\partial L}{\partial P_i} = \frac{\partial F_i}{\partial P_i} - \lambda \quad \text{since } P_D = \text{power demand, is constant}$$

The cost is minimum when $\frac{\partial L}{\partial P_i} = 0$, or: $\frac{\partial F_i}{\partial P_i} - \lambda = 0$, or:

$$\boxed{\frac{\partial F_i}{\partial P_i} = \lambda} \quad (8.7)$$

This is the same as equation (8.1), obtained by using the intuitive method.

8.6 The Incremental Cost λ of many plants with long line losses

The previous section emphasized the equal λ criterion for economic distribution of loads between generators, which are either in the same plant or close enough electrically to neglect line losses.

An extension of this method uses the concept of "penalty factors" for correcting the plant λ 's to include the effects of transmission losses.

In this case, the production P_i must satisfy the relation :

$$\sum_{i=1}^n P_i - P_{\text{Loss}} = P_{\text{Demand}} \quad \text{Constant}$$

$$\text{or:} \quad \sum_{i=1}^n P_i - P_L - P_D = 0 \quad (8.8)$$

where n is the number of plants.

By forming the Lagrangian equation:

$$L(x, \lambda) = F_i - \lambda_i \left(\sum_{i=1}^n P_i - P_L - P_D \right) \quad (8.9)$$

Since the loss P_L varies with each generator output P_i , the minimum fuel cost F_i is obtained when: $\frac{\partial L}{\partial P_i} = 0$ or:

$$\frac{\partial F_i}{\partial P_i} - \lambda_i + \lambda_i \frac{\partial P_L}{\partial P_i} = 0 \quad (8.10)$$

The solution of equation (8.10) gives :

$$\lambda_i \left(1 - \frac{\partial P_L}{\partial P_i}\right) = \frac{\partial F_i}{\partial P_i} \quad \text{or}$$

$$\lambda_i = \frac{\partial F_i}{\partial P_i} \frac{1}{1 - \frac{\partial P_L}{\partial P_i}} \quad (8.11)$$

Hence:

$$\lambda_i = \frac{\partial F_i}{\partial P_i} L_n \quad \text{where}$$

$$L_n = \frac{1}{1 - \frac{\partial P_L}{\partial P_i}} \quad (8.12)$$

is referred to as "penalty factor".

The above development outlines only one of the many techniques used in economic dispatch problem. Detailed development and computer solution can be found in reference 4, chapter 13.

CHAPTER 9SCHEDULING (UNIT COMMITMENT) PROGRAMS [4]9.1 Introduction

Scheduling or Unit Commitment concerns economic dispatch system, and is defined as: the determination and use of an optimum combination of generators to provide the hourly load demand.

Many items must be weighted in a scheduling program. These items include:

- 1- A short term load forecast
- 2- System reserve requirements
- 3- System security
- 4- Start up costs for all units
- 5- Minimum level fuel costs of units
- 6- Incremental fuel costs of units
- 7- Shut down costs for all units
- 8- Maintenance costs
- 9- Costs due to transmission-line loss
- 10- Cost of purchasing interchange power

9.2 Methods for Scheduling Units

A number of techniques have been used in an attempt to schedule the best possible combination of units.

Two of these methods are now being considered:

9.2.1 Priority List Scheduling

This method ranks the units in order of preference, according

to their fuel costs per KWH. The dispatcher takes the sum of the hourly load demand plus the reserve requirements, and schedules enough units with sufficient capacity to match this sum. For the shutting down of units, the reversed priority must be used, after weighting the various costs.

Once units have been committed to service, the equal λ criterion for loading would be automatically applied, assuming the system has an economic dispatch computer in service.

9.2.2 Dynamic Programming

This technique is used to optimize the process of scheduling over a given period of time. This period of time is broken up into stages, usually of one hour. Decisions are to be made at the beginning of each hour as to whether to place units into service or withdraw them from service.

The load demand and reserve requirements are assumed known over the total period, along with other operating constraints. Total costs over the period are to be minimized.

9.3 Scheduling Programs

An actual scheduling program provides the computations for both the scheduling and the forecasting functions in the following operational cases:

- 1- Generation and Interchange Scheduling
- 2- Hydrometeorological and Load Forecasting
- 3- Joint Interchange Scheduling

The scheduling function is one of prediction; consequently, the computations are made to generate data for future use.

The processing of the input data consists of the following tasks:

- 1- Identifying incoming data from many sources and using it to update the various data files.
- 2- Accessing the data for use by the Scheduling Programs.
- 3- Executing the scheduling programs.
- 4- Outputting the data into files for use by others applicable programs, displays, hard copy logs and reports.

A functional diagram for scheduling is shown in fig. 9.1

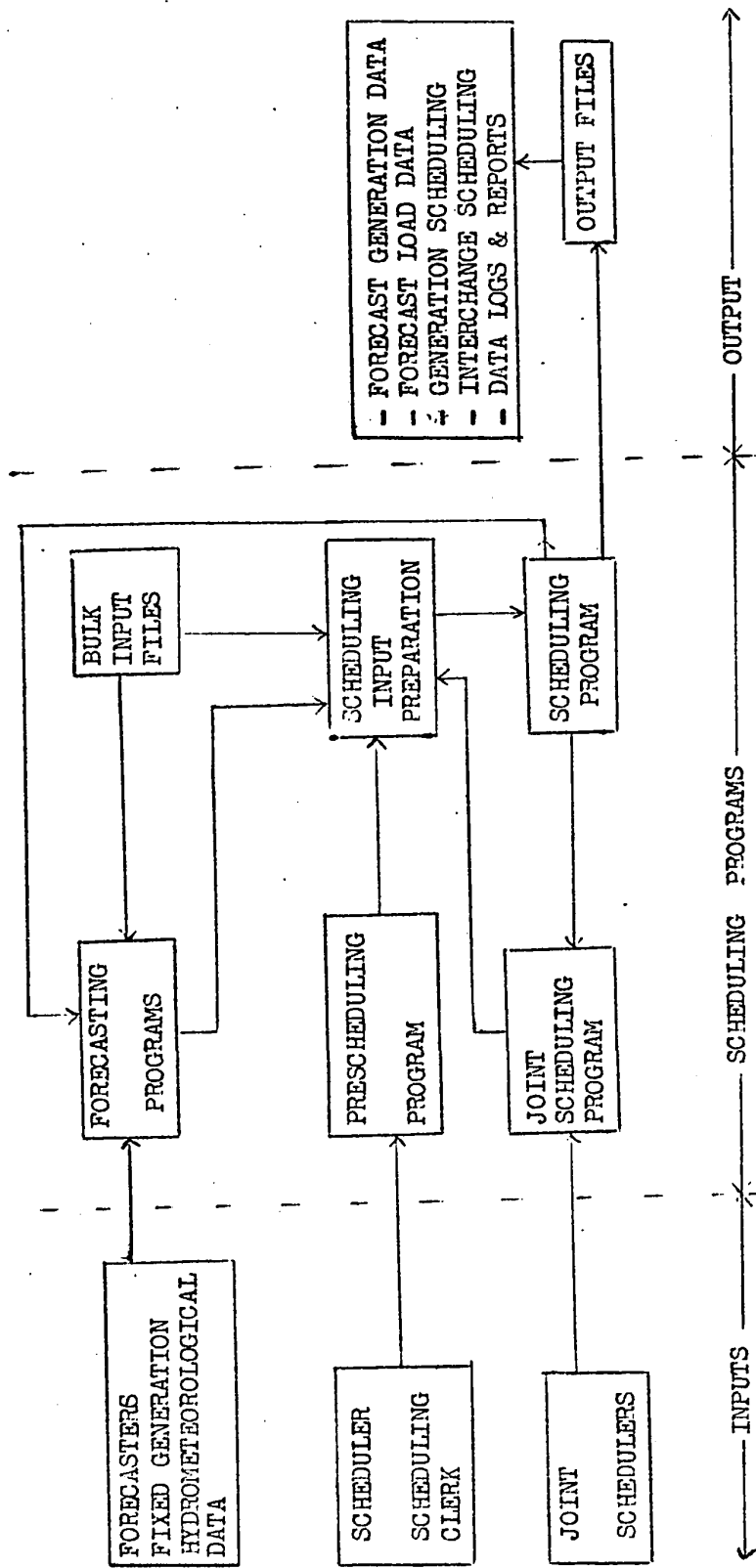

Fig. 9.1 Functional Diagram of Scheduling Program.

CHAPTER 10

WATT-FREQUENCY and VAR-VOLTAGE CONTROL [1]

10-1 Introduction

By applying Load Flow and Economic Dispatch methods, as explained in chapter 9, load can be distributed among various customers without endangering power system constraints.

This chapter will explain how control action can be taken on :

- 1- the turbine regulator to obtain a desired watt production, and
- 2- the voltage regulator of the generator to maintain the desired amount of vars, hence to control voltages at various nodes of the electric system.

10-2 Turbine Governor Control or Power Frequency Control (Pf)

At any given instant, the power production must be equal to the power demand, if the desired frequency is to be maintained.

For any alternator, the speed, and hence the frequency, is related to the produced power by a curve, such as that of fig. 10.1.

Point A in the curve gives the equilibrium, where demand power equals the produced power, and the frequency is maintained at 60 Hz.

If the generator output is higher than the demand, the machines will tend to increase their speed and the frequency will rise, and vice versa.

By controlling the action of the turbine regulator, to regulate the steam or water admission into the turbine, a desired power output can be

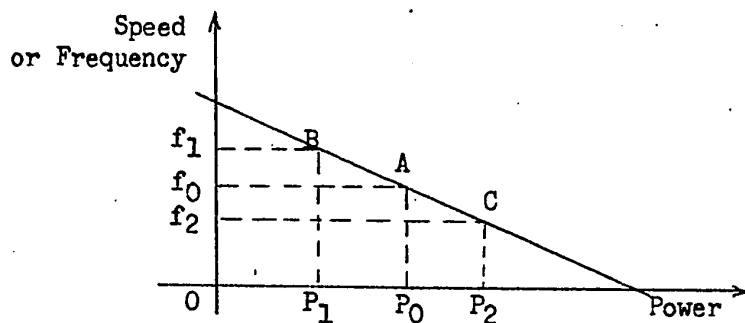

Fig.10.1 Power Production in function of Frequency

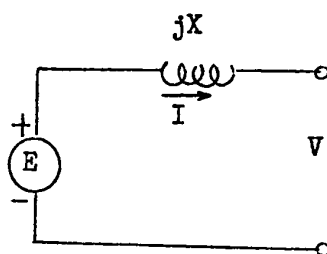

Fig. 10.2 Circuit of a Generator

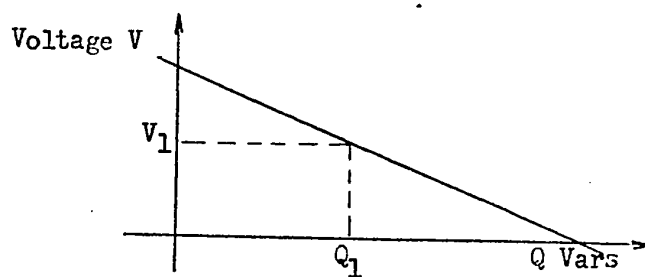

Fig. 10.3 Var Production in function of Generator Terminal Voltage.

obtained. This type of control is referred to as "the Power Frequency Control" or Pf Control, or Load Frequency Control(LFC).

10.3 Voltage Regulator Control or Var-Voltage Control (QV)

Consider the circuit of a generator shown in fig.10.2,where:

$X = \text{reactance}; \quad V = \text{terminal voltage}; \quad E = V + j I x$

The variation of V with respect to vars production is shown in fig. 10.3

The voltage regulation at a bus can be controlled by adjusting the reactive power production at each generator.

This control action is called:Var-Voltage Control or QV Control.

Var generation is varied by reducing or increasing the excitation of the generator. Chapter 2 has shown that the reactive power is generated by over-excited synchronous machines which also absorb vars when under-excited.

The device used to change the generator terminal voltage is called "automatic voltage regulator".

10.4 Interaction of Pf and QV control.

Fig. 10.4 shows the implementation of the Pf and QV control.

In a static sense and for small deviations,there is little interaction of these two control loops.

In general,the QV loop is much faster than Pf loop,due to the mechanical inertia constants in the latter.

This feature makes possible the study of the two loops separately.

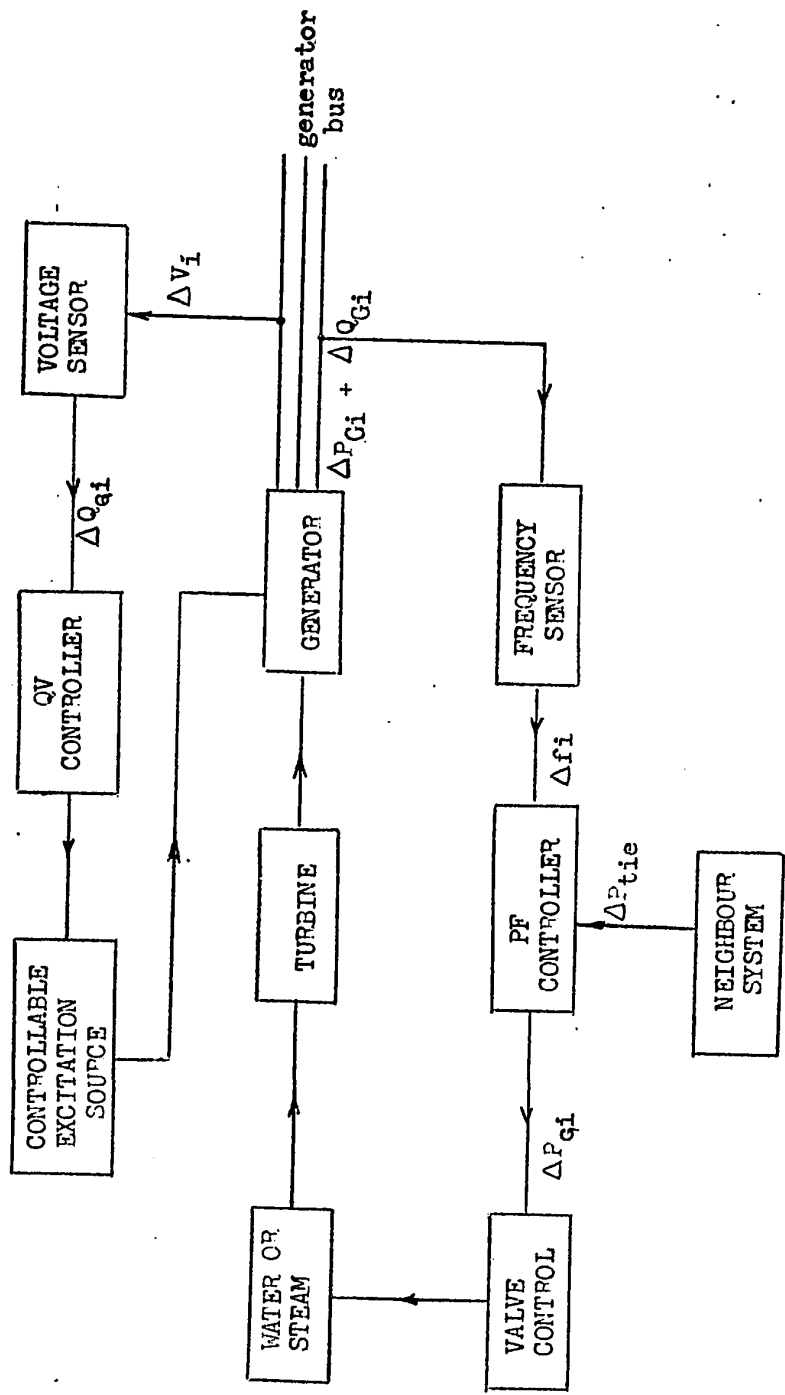

Fig. 10.4 Relationship between Pf and QV loops.

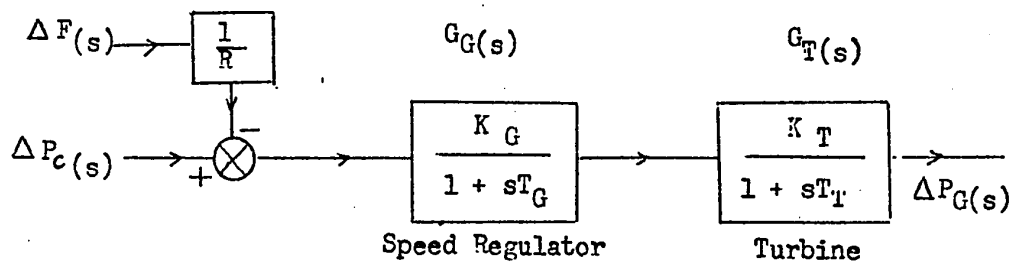

Fig.10.5 Transfer Functions of LFC loop.

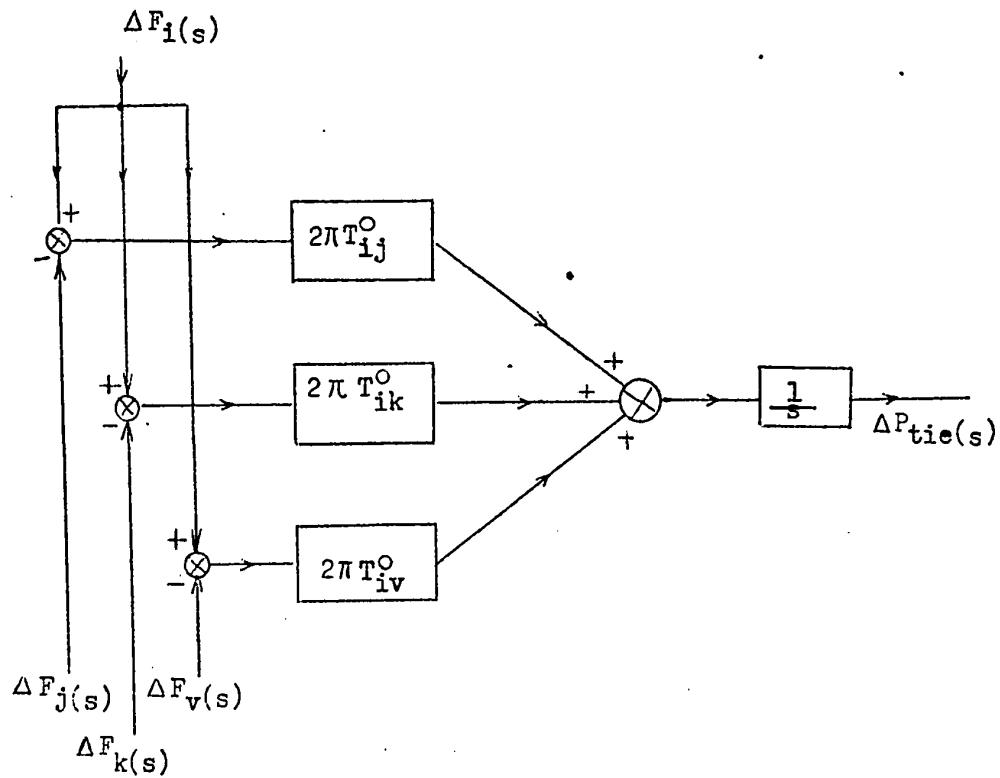

Fig. 10.6 Block Diagram of a Tie-Line.

10.5 The Watt Frequency Control [1]

10.5.1 Speed Governor Model.

For a small deviation of power demand, the speed regulator of a turbine can be represented by a transfer function :

$$G_G(s) = \frac{K_G}{1 + s T_G} \quad (10.1)$$

where: K_G = static gain of speed governing mechanism.
 T_G = time constant of speed governing mechanism.
 s = Laplace variable = $j\omega + \sigma$

10.5.2 Turbine Model.

A turbine can be represented by the following transfer function:

$$G_T(s) = \frac{K_T}{1 + s T_T} \quad (10.2)$$

where: K_T = gain factor.
 T_T = time constant of turbine .

The combined representation of the speed governor and the turbine is shown in fig. 10.5, where:

ΔF = frequency deviation.

ΔP_c = Watt deviation.

$1/R$ = speed regulation due to governor action

$R = \frac{\text{variation of frequency } \Delta f}{\text{variation in load } \Delta p}$

10.5.3 Power System Transfer Function

The Power System Transfer Function is given by:

$$G_p(s) = \frac{K_p}{1 + sT_p} \quad (10.3)$$

where K_p = gain and T_p = time constant.

10.5.4 Tie-line Transfer Function

The tie-line power between neighbouring systems is represented by:

$$\Delta P_{\text{tie}} = T_{iv}(\Delta\delta_i - \Delta\delta_v)$$

where T_{iv} is the synchronizing coefficient or stiffness of the tie-line. From chapter 2, the power transmitted over a line is given by:

$$P = P_m \sin(\delta_i - \delta_v)$$

and the stiffness is defined as:

$$T_{iv} = \frac{dP}{d\delta} = P_m \cos(\delta_i - \delta_v)$$

where δ_i, δ_v are the phase angles of nodes i and v , and $\Delta\delta_i$ and $\Delta\delta_v$ are the increments.

In static operation, the angular frequency $\omega^0 = 2\pi f_0$ is constant and the bus voltage has the form:

$$v_i = V_{\text{max}} \sin(\omega_0 t + \delta_i^0)$$

For a small change: $\delta_i = \delta_i^0 + \Delta\delta_i$

$$|V_i| = |V_i^0| + \Delta|V_i|$$

and v_i becomes: $v_i = \left[|V_i^0|_{\text{max}} + |\Delta V_i|_{\text{max}} \right] \sin(\omega^0 t + \delta_i^0 + \Delta\delta_i)$

The angular velocity is:

$$\omega_i = \frac{d}{dt} (\omega^0 t + \delta_i^0 + \Delta\delta_i) = \omega_i^0 + \frac{d}{dt} \Delta\delta_i$$

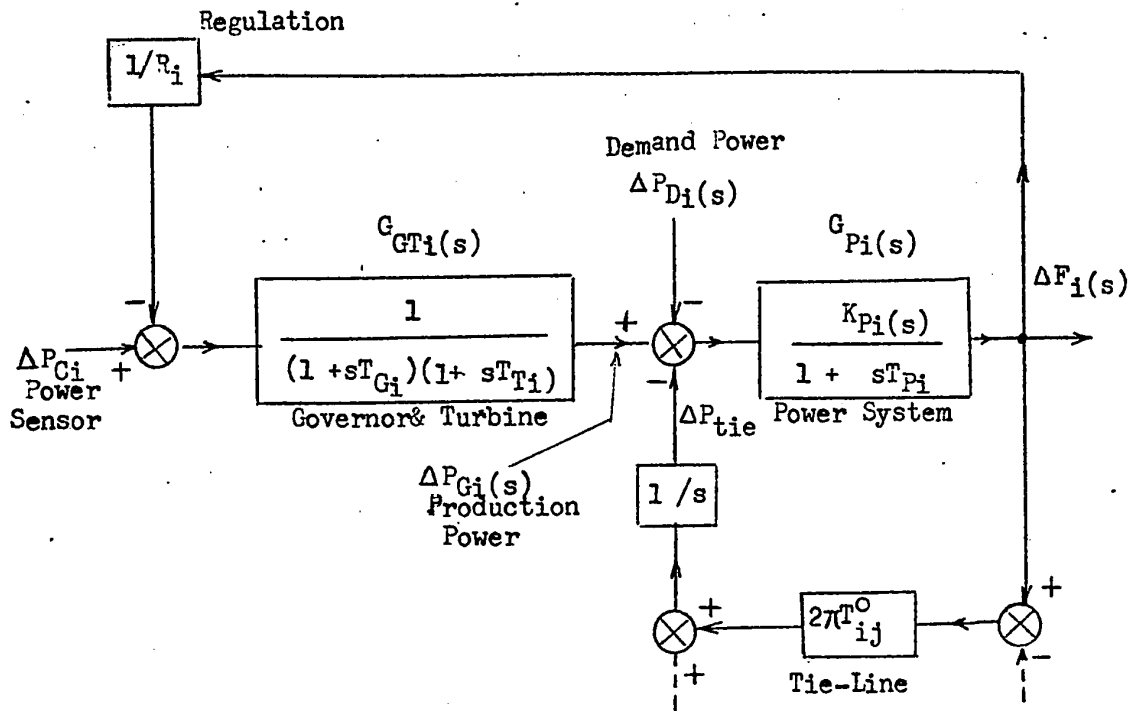

Fig.10.7 Complete Block Diagram Representation of a Control Area i.

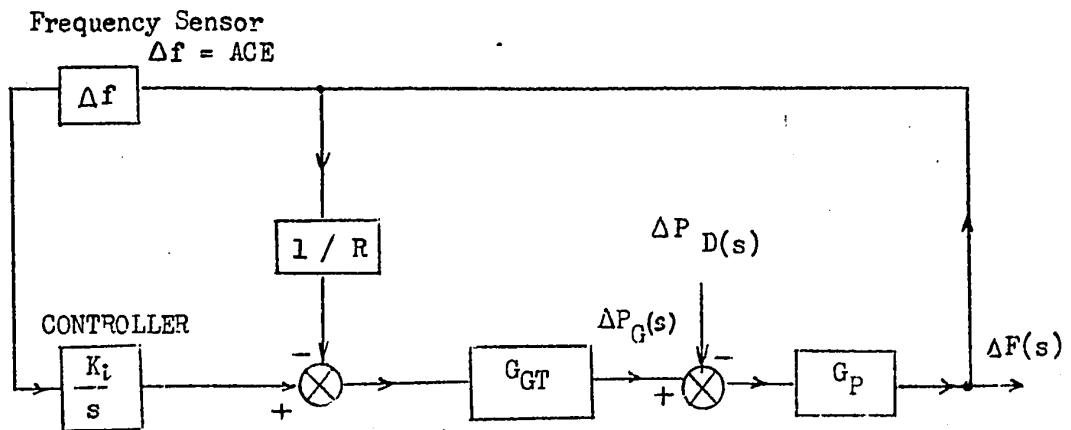

Fig.10.8 Controlled Area i.

and:

$$\Delta \omega_i \cong -\frac{d}{dt} \Delta \delta_i$$

or, expressed in cycles per second:

$$\Delta f_i = -\frac{1}{2\pi} \frac{d}{dt} \Delta \delta_i \quad (10.4)$$

or:

$$\Delta \delta_i = 2\pi \int \Delta f_i dt \quad (10.5)$$

Return now to the equation: $\Delta P_{tie} = T_{iv}(\Delta \delta_i - \Delta \delta_v)$ given above;
by using (10.5) it becomes:

$$\Delta P_{tie} = 2\pi T_{iv} \left(\int \Delta f_i dt - \int \Delta f_v dt \right) \quad (10.6).$$

By taking Laplace transform of (10.6), it gives:

$$\Delta P_{tie}(s) = \frac{2\pi}{s} T_{iv} \left[\Delta F_i(s) - \Delta F_v(s) \right] \quad (10.7)$$

If a system has many tie-lines, then ΔP_{tie} can be obtained as :

$$\Delta P_{tie}(s) = \frac{2\pi}{s} \sum T_{iv} \left[\Delta F_i(s) - \Delta F_v(s) \right] \quad (10.8)$$

Equation (10.8) can be represented by the block diagram of fig. 10.6.

10.5.5 The uncontrolled case

The transfer functions developed so far can be used to obtain a complete block diagram of a control area in a power system, as in fig. 10.7. This diagram shows an uncontrolled case, since there is no controller to act upon the variation of the power error resulting from a difference between the production and the demand.

10.5.6 The controlled case

The current practice is to add an integral controller to the arrangement of fig.10.7 ,to improve the loop stability, and to reduce the frequency error, following a step load change. This is shown in fig. 10.8.

The signal fed into the controller is referred to as "Area Control Error".

The design of the controller to be used in a multi-area control case, is developed in [1]. A modern method using state variable technique and optimal control theory is also discussed in the same reference.

10.6 The Var-Voltage Control [1]

.1 Transfer function of exciter system

Fig. 10.9 shows a general set-up of a var-voltage control loop.

2 Voltage comparator

This device compares the terminal voltage $|V|$ of the generator with a reference voltage, equal to the nominal voltage $|V^0|$.

The voltage error is :

$$e \triangleq |V|_{\text{ref}} - |V| = |V^0| - (|V^0| + \Delta |V|) = -\Delta |V|$$

3 Exciter

Basically, this is an amplifier and has same transfer function:

$$\frac{V_r(s)}{V_2(s)} = \frac{K_E}{1 + sT_E} \quad (10.9)$$

the time interval T_E is about 1 sec.

4 Amplifier

Here the transfer function is:

$$\frac{V_2(s)}{V_1(s)} = \frac{K_A}{1 + sT_A} \quad (10.10)$$

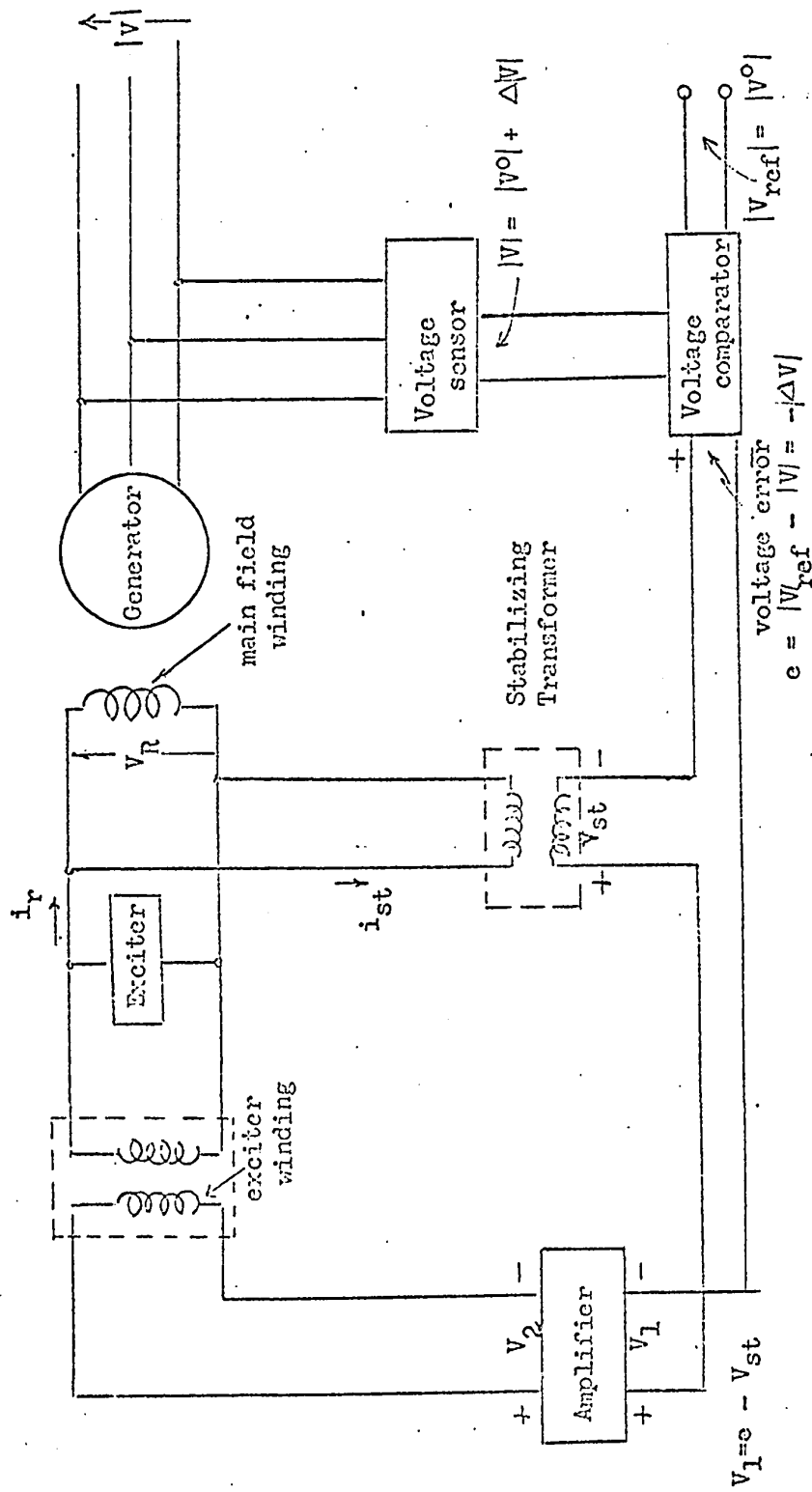

Fig. 10.9 The Var-Voltage control loop

5 Generator

The transfer function in a nominal operating state of the generator is:

$$\frac{V(s)}{V_r(s)} = \frac{K_r}{1 + sT_r} \quad (10.11)$$

the time constant T_r has a value of several seconds.

6 Stabilizing circuit

Since there are three main components of first order in the control loop (Amplifier, Exciter, Generator), the stability of the loop would be impaired, and a circuit is needed to stabilize this.

The transfer function of the stabilizing circuit is:

$$\frac{V_{st}(s)}{V_r(s)} = \frac{s K_{st}}{1 + s T_{st}} \quad (10.12)$$

The control loop is now modified as shown in fig. 10.10.

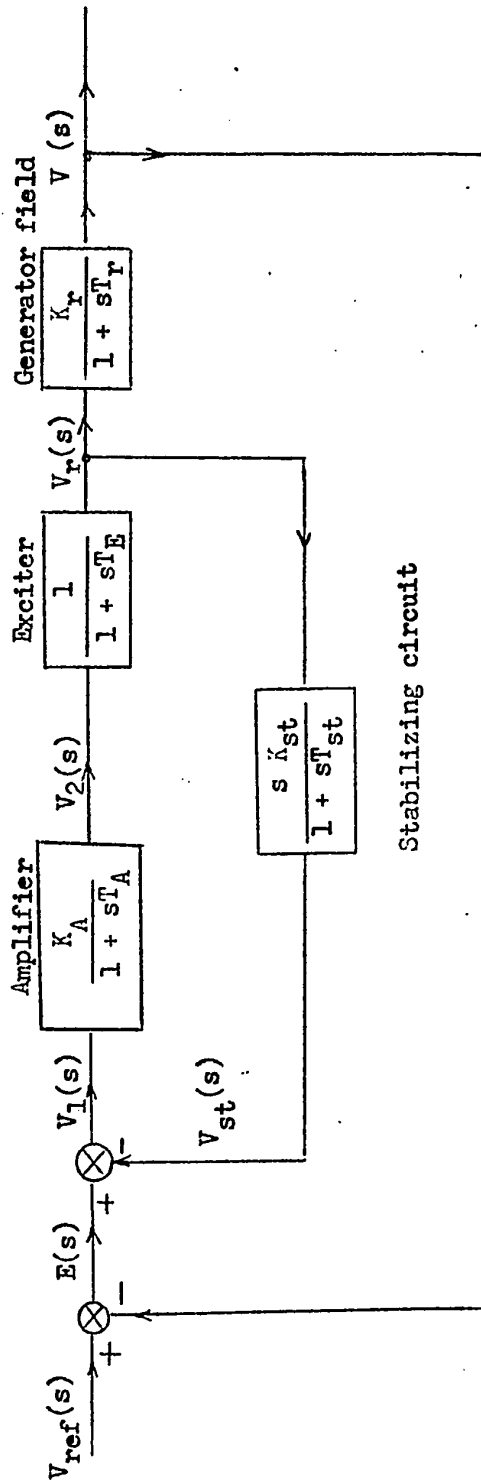

Fig. 10.10 Complete Block Diagram of the QV Control loop

CHAPTER 11POWER SYSTEM STABILITY11.1 Classification of Power System Transients

According to their speed, transients can be classified into three classes, as follows:

- 1- Ultra-fast Transients. Surge phenomena. (First few milliseconds after a fault)

They are transients giving rise to overvoltages caused by atmospheric discharges on transmission lines and by abrupt, though normal, changes resulting from regular switching operations.

The study of these transients determines the insulation level of the equipment.

- 2- Medium-fast Transients. Short circuits. (10 - 100 ms)

Most short circuits on transmission lines are caused by birds and mechanical failure of insulators, lines, etc. These short circuits could occur on three phases (balanced) or on one or two phases (unbalanced short circuits). The knowledge of the magnitude of current caused by these short circuits is helpful in selecting proper circuit breaker and suitable relays.

- 3- Slow Transients. System Stability. (1 sec. - 1 min.)

An ultra-fast transient may give rise to a short circuit, which on a vital link can develop into the most dangerous type of slow transient, the mechanical oscillation of machine rotors.

The electromechanical slow transient can pull some of the machines

out of synchronism which in turn, by chain action, might cause a complete system black-out. Only slow transients will be considered in the development of the dispatching center software, since the fast transients are used primarily by planning personnel to study and design the power network. The study of these slow transients determines whether or not the machine power angle δ (or torque angle) will stabilize after a sudden disturbance. If a study reveals that δ continues to increase (or decrease) after a disturbance, the machine will of course go out of step with the system, and a system black-out could result. On the other hand, if provision can be made to alleviate the extreme condition (such as faster relaying for isolation of a faulted line) the unstable situation may be avoided without loss of the generator.

11.2 Behaviour of the synchronous machine during a balanced short circuit.

If a short circuit is applied on the terminals of the synchronous generator, the transient envelope of fig. 11.1 will result.

The damper windings carry no current in steady state operation, but when the machine is subject to power angle oscillations, stabilizing currents will be induced in the winding for a very short time of a few cycles.

A subtransient x_d'' is defined for that period and the rms current is: $\frac{E''}{x_d''}$. Synchronous machines are represented by an emf E behind either the subtransient x_d'' , or the transient x_d' (depending upon whether the short circuit current is required immediately after the short circuit or after about 3 or 4 cycles), or by x_d in steady state study, as shown in fig. 11.2

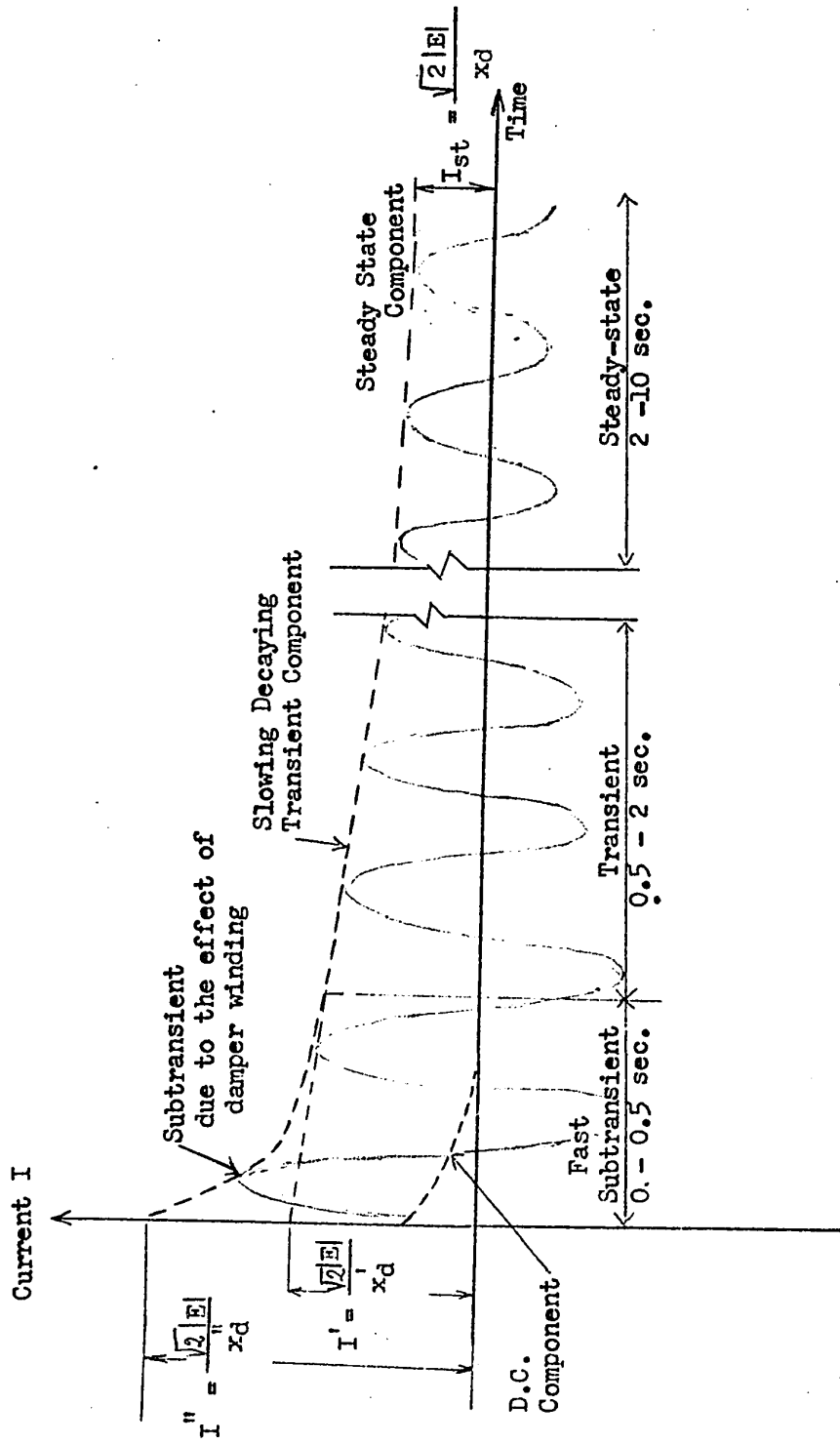

Fig. 11.1 Transient stator short-circuit current of synchronous machine.

11.3 Determination of power angle δ by using the Swing Equation [3]

A general representation of a turbine power and a generator power is shown in fig. 11.3.

In order to determine the angular displacement between the machines during a transient condition, the equation describing the motion of the machine rotors must be solved.

The Swing Equation of a generator is developed in detail in reference [3] as :

$$\frac{d^2\delta}{dt^2} = \frac{\pi f}{H} (P_m - P_e) \quad (11.1)$$

where: δ = power angle in radian

f = system frequency in Hz

H = inertia constant of a machine, defined as the kinetic energy at rated speed. H is expressed in Kw sec / Kva

P_m = mechanical power

P_e = electrical air gap power

But :

$$\frac{d\delta}{dt} = \omega - 2\pi f \quad (11.2)$$

where: ω = rated synchronous speed in rad/sec.

Equation (11.1) now can be written as:

$$\boxed{\begin{aligned} \frac{d\omega}{dt} &= \frac{\pi f}{H} (P_m - P_e) \\ \frac{d\delta}{dt} &= \omega - 2\pi f \end{aligned}} \quad (11.3)$$

This is the Swing Equation in practical form. Solving (11.3) by numerical method gives the curves of δ with respect to time; hence the stability of the generator can be determined.

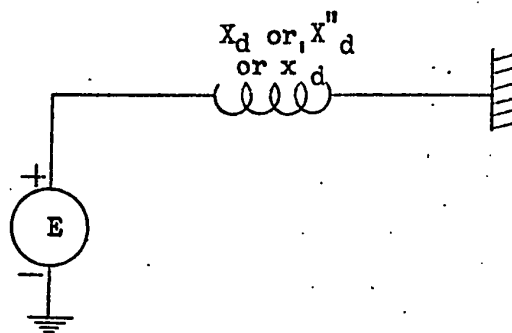

Fig. 11.2 Generator Representation.

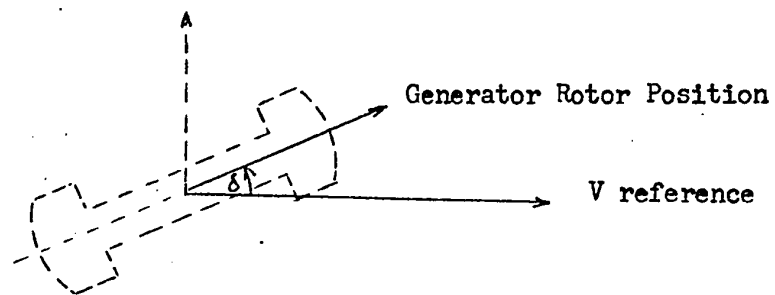
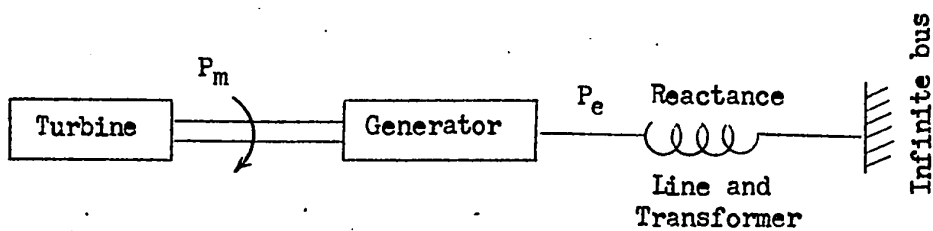

Fig. 11.3 Representation of turbine and generator with the power angle.

11.4 Stability Problem Solutions

There are two methods used in solving the swing equation:

1- Classical method solves numerically the differential swing equation by digital computer or analog computer.

Stability or lack of it is determined from the looks of the resulting curves.

2- Modern method, also called "direct method", determines the stability without actually solving the differential equations.

So far, the direct solutions by Liapunov method are only of academic interest and not yet applied to an actual power system.

The computer solution of the swing equation by classical method is given in [3]. The solution using modern method approach is developed in [8].

CHAPTER 12

CONTINGENCY ANALYSIS

12.1 Objectives of Contingency Analysis in Power System.

The objectives of Contingency Analysis are:

- 1- to monitor the current system state and alarm the dispatcher when the system is in a vulnerable condition, and
- 2- to suggest appropriate corrective actions to bring a vulnerable system into a secure operating state.

A system is considered vulnerable if a possible next contingency would result in significant departure from normal system frequency, or in below-standard voltages at some nodes, or in system instability, or in overloads in some circuits. The next contingency might be the loss of any circuit, generator or load.

In order to be declared secure, an operating system must be capable of withstanding the following after-effects of any contingency:

- a) the fast transient phenomenon, immediately following the disturbance, which could cause the loss of synchronism between various groups of generators.
- b) the slow transient effect, which could cause prolonged overload of equipment, or non-standard voltages before the speed regulator can be readjusted.
- c) the new steady-state load flows and voltages in the remaining system, after the speed regulator outputs have been readjusted and the available power reserve has been utilized.

The first and second case will be referred to as "Transient security" and the third case is known as the "Steady-state security".

An algorithm is necessary to find the best corrective action after each contingency and is named: corrective scheduling algorithm.

The flow chart of fig. 12.1 shows one of the many organizations of security functions or Contingency Evaluation Program.

12.2 Steady-State Contingency Evaluation Program.

Only the case of Steady-state Contingency is considered here, since for transient contingency, the analytical methods are not adequate for a prediction of the vulnerability of an existing system.

The roles of the Steady-State Contingency Program are:

- 1-to calculate the effect of every transmission line and transformer outage, taken one at a time, and mark those which are overloaded.
- 2-to examine bus voltages during each outage and mark those which lie outside the specified range.
- 3-to suggest relief measures to alleviate the system from any abnormal condition found under 1,2 above.
- 4-all these functions are to be performed continuously.

12.3 Methods of Contingency Analysis.

There are two methods for performing Contingency Analysis:

- a) Method of superposition
- b) Methods based upon linearized load flow equations.

All methods for computation of contingencies must be fast, so that a large number of outages can be studied in a short time.

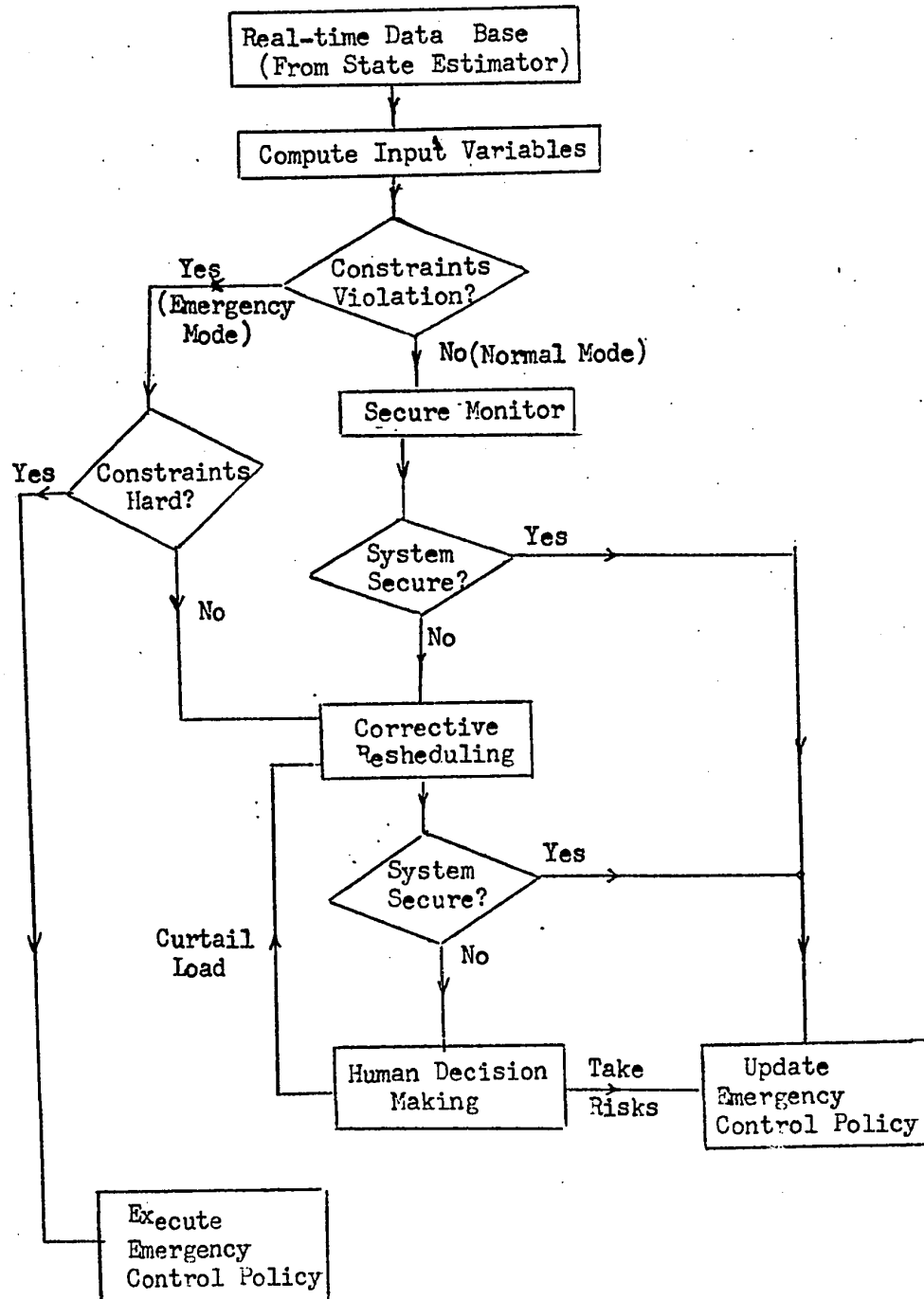

Fig.12.1 Flowchart of Security Related Functions.

The algorithm must be simple; only minimum of memory storage is hence required.

a) Method of superposition

The simplest and most direct calculation of contingencies is based upon the principle of superposition.

It is assumed that the power system elements are linear; hence line currents and bus voltages of the system in the pre-outage state and post-outage state can be computed and added. These new values of line currents and bus voltages are now examined against a known list of allowable voltage limits and line overload capabilities. If the limits are exceeded, then the system is in a vulnerable state.

The computation of the new values of voltages and currents can be simplified by using the concept of distribution factor $K_{rs,pq}$.

The distribution factor represents a change in the current of line rs due to each ampere of current in line pq when the latter is disconnected from the network.

Detailed development of Contingency Analysis using the superposition method is given in [9].

b) Method based upon Linearized Load Flow Equations

One of the disadvantages of the superposition method is that it does not allow for a change in voltage profile as a result of the contingency.

In the linearized load flow methods, the outage calculation produces a voltage-change vector $|\Delta E| = |Z' \cdot \Delta I|$

(where Z' = Impedance ; ΔI = current-change vector)

which in general will not be the actual voltage magnitude change experienced by the system. This is obvious in voltage controlled busses,

where voltage magnitude changes are compensated for by vars regulation. These voltage magnitude discrepancies are corrected by an iterative technique. This reduces, of course, the computation speed. Methods for such an iterative voltage correction have been described in ref.10.

CONCLUSIONS

A general description of the hardware/software design of a Dispatching Center in an Electrical Utility has been completed in this report.

An outline of an actual Power System configuration has been followed by a review of some of the most important network concepts and equations. Then, the role of a Dispatching Center has been briefly treated.

In chapter 3, the equipment used in a Dispatching Center (or Master Station) and remote stations (transformer stations, generating stations, etc.) has been described.

It has been shown that in a Dispatching Center, the main hardware is :the Computer System, the Data Acquisition System and the Display System. In remote stations, the main equipment is the Data Gathering System.

The telecommunications systems, although they do play an important role in a Dispatching Center hardware, have not been discussed, since they lie outside the scope of this report.

General Computer Software and detailed Applications Programs used in a Dispatching Center have been the last topics of this technical report. Due to the lack of space, only the most popular techniques used in the development of Application Programs have been described. However, advanced techniques have been referred to in the literature.

It is hoped that this report has shown a general view of the operation of a Dispatching Center ;hence it can be possibly used as an introductory document to the design of a Dispatching Center.

REFERENCES

Books, Technical Reports and Papers.

- 1-Elgerd, Olle I.: " Electric Energy Systems Theory: An Introduction "

Mc Graw-Hill Book Company, New York, 1971, pp.183, 321-314, 366-369.
- 2-Stevenson, W.D.: "Elements of Power System Analysis" Mc Graw-Hill

Book Company, New York, 1962.
- 3-Stagg, G.W. and A.H. El-Abiad: "Computer Methods in Power System Analysis"

Mc Graw-Hill Book Company, New York, 1968, pp.260, 261, 366, 369.
- 4-Newenswander, J.R. " Modern Power Systems ", International Textbook CO.

Scranton, 1971, pp. 50-52, 301-303, 327-330.
- 5-Weedy, B.M. : "Electric Power Systems", John Wiley & Sons, New York, 1967

pp. 34, 46, 51.
- 6-North American Rockwell Information Systems Co. : " Real- Time Dispatch

Control & Application Processor, Design Considerations for the Ross
 Control Center (Bonneville Power Administration) :Advanced Control and
 Dispatch Program ", Dec. 31, 1969, chap. 5,7.
- 7-Larson, R.E., Tinney, W.F., Peschon, J.: "State Estimation in Power Systems",

Part 1: Theory and Feasibility; Part 2: Implementation and Applications.
 IEEE Transactions on Power Apparatus and Systems, Vol. PAS- 89, no. 3,
 March 1970, pp. 345-363.
- 8-Natesan, T.R., Smoak, R.A., "On the Choice of Optimum Quadratic V-functions

for Multimachine Power System Stability Studies ", Paper no. 71CP34-PWR
 IEEE Winter Power Meeting , New York, Jan. 31, 1971.
- 9-Limmer, D.H., "Techniques and Applications of Security Calculations

applied to Dispatching Computers ", PSCC, Rome, 1969.

10-Peterson, N.M., Tinney, W.F., Bree, D.W., "Iterative Linear A.C. Power Flow for Fast Approximate Outage Studies ", paper no. T 72-140-7, IEEE Winter Power Meeting, Feb. 1972, New York.

BIBLIOGRAPHY

Short Courses Notes

- 1-School of Electrical Engineering, Purdue University: "Computation Methods for Power Systems Analysis ", June 16-20,1969.
- 2-Case Western Reserve University ." Real-time Computer Systems for Data Acquisition, Information Processing and Control " Jan. 24-28, 1972.
- 3-Department of Engineering, the University of Wisconsin. "Real-time Monitoring & Control of Power Systems ", June 5-16,1972.
- 4-University of Toronto, Department of Electrical Engineering, "Digital Computers in Power Systems Engineering." May,1968.

Technical Papers

- 5-Chareyre L., "Système de téléinformation pour les dispatchings et les centres de manoeuvre ". Electricité de France, Sao Paulo, 11 Avril,1972
- 6-Brown-Boveri Revue, "Problèmes d'automatisation de reseaux ". Revue no. 7, Juillet 1972, tome 59.
- 7-Schoffen, H.W., Alexander, S.M., Lavander, J.E., "Computer Directed Control and Automatic Data Processing for a Hydro-Electric Generation System". IEEE Trans. on Power Apparatus and Systems Vol. PAS-87, no.1, Jan.1968.
- 8-Dy Iacco, T.E., Wirtz, B.F., Wheeler, D.A., " Automation of the CET system for Security" Paper 71, C26-PWR III A, At 1971 PICA Conference , Boston, Mass., May, 24-26, 1971.