

A REVIEW OF THEORIES OF FATIGUE
FAILURE DUE TO RANDOM LOADING

by

Waheed Ghulam Rabbani

A Major Technical Report

in

The Faculty

of

Engineering

Presented in Partial Fulfilment of the Requirements for
the Degree of Master of Engineering at
Sir George Williams University
Montreal, Canada
March, 1974

- 1 -

ABSTRACT

This report presents a brief review of the more important theories of fatigue failure prediction due to random loading. The method of the statistical description of the random loading process is first shown. The current theories are classified into (a) where the damage is considered to be deterministic (b) where the damage is a random process and (c) where the material property changes are included.

Some applications to practical design problems are shown. A random fatigue testing procedure is outlined. A further review of the latest developments in the Fracture Mechanics Flaw propagation approach to fatigue reliability of randomly excited structures is also discussed.

Some applications to design against random fatigue are indicated.

Recommendations for further experimental work are made.

ACKNOWLEDGEMENTS

Thanks are due to Professor T.S. Sankar for the supervision of this research project and for the useful discussions, guidelines and reference material in the preparation of this report. Special thanks are due to Professor P. Srinivasan, visiting professor at Sir George Williams University, for his help and guidance.

TABLE OF CONTENTS

	page
ABSTRACT	i
ACKNOWLEDGEMENTS	ii
LIST OF FIGURES	v
CHAPTER 1	
Introduction	1
CHAPTER 2	
Description of Random Loading	6
CHAPTER 3	
Review of Damage Theories	13
3.1 Introduction	13
3.2 Deterministic Damage Random Load Theories	13
3.2.1 Limitations	17
3.3 Theories with Damage Parameters as Random Variables	17
3.3.1 Discussion	24
3.4 Theories that Consider Material Property Changes	26
CHAPTER 4	
A Random Load Fatigue Testing Procedure	31
4.1 Introduction	31
4.2 Determination of Service Loading	31
4.3 Random Load Fatigue Testing Machine	33

4.3.1	Loading Sequence and Relays	33
4.4	Testing and Results	34
4.5	Effect of Assumptions and Errors	35
CHAPTER 5		
	Application to Design Problems	41
CHAPTER 6		
	Conclusions and Recommendations	47
REFERENCES		51
APPENDICES		
Appendix A		
	The Fracture Mechanics-Flaw Propagation Approach	56
Appendix B		
	A Brief Review of the Fracture Mechanics Theory	68

LIST OF FIGURES

<u>Fig. No.</u>	<u>Title</u>	<u>Page No.</u>
2.1	Analysis of Periodic Loading	11
2.2	Analysis of Random Loading	12
3.1	Logarithmic Plot of Typical S-N Curve	29
3.2	Stress Strain Hysteresis Loop	30
4.1	Probability Distribution of Loads	37
4.2	Sketch of Fatigue Testing Machine	38
4.3	Schematic of Loading Relays	39
4.4	Typical S-N Diagram	40
5.1	Model for Jet Exhaust Loading on Panel	45
5.2	Model for Random Fatigue Analysis	46
5.3	Results of Analysis	46
A.1	Crack Depth vrs Stress Cycles	67
B.1	Stress Acting on Element of Material Near Crack Tip.	72
B.2	Fatigue Crack Growth Rate Correlation	73

CHAPTER 1

INTRODUCTION

The fatigue design of the industrial machines, where the dynamic loads are usually sinusoidal, is simply to somewhat 'over design' so as to ensure that the maximum possible cyclic stress times a factor of safety is well below the endurance limit of the material. However, with the introduction of lighter and complex structures, notably the aerospace vehicles, dynamic stresses can no longer be kept below the endurance limit. In such instances an estimate of the fatigue life is necessary.

The unfortunate Comet aircraft disasters in 1954 caused grave concern and aroused interest in combating fatigue in aircraft structures. It was recognised that the loads induced on aerospace structures are predominantly random rather than periodic in nature e.g. the loads due to gust, manoeuvre, noise, landing and taxiing. Random loads are described statistically by considering that the loading spectrum consists of a sequence of cycles, the amplitudes of which represent a random selection from a population which have been observed to occur in proportion to their relative frequency of occurrence. The problem of determining the stresses and fatigue life from random loading is now receiving attention. The reliability of the aerospace structure is based on its fatigue life, which puts a great emphasis on the method of fatigue life estimation in random environment.

This report presents a review of some of the more important theories

of cumulative fatigue damage under random loading, which have been proposed recently.

Fatigue failures have been common occurrence ever since metal structures were first designed. Extensive research has been directed towards understanding the phenomenon and preventing such failures. Pioneering investigations were made by Poitelet [1], W.J. Rankine [2] and Wohler [3]. The importance of studying fatigue by experimental methods cannot be over emphasised. Wohler was the first to design special fatigue testing machines. A variety of tests e.g. push-pull, rotating beam etc. at constant stress amplitude have been conducted. The typical Stress vrs Number of cycles (S-N) curves have been constructed. The concept of the material 'endurance limit' discovered from the S-N curves is now well known.

A distinguishing feature of fatigue is the cyclic nature of load or stress application resulting in progressive damage leading to failure. No particular cycle is solely responsible for the total damaging effect but rather a 'cumulative' effect of each cycle.

The most commonly used method to predict the fatigue life was proposed by Miner [4] and earlier by Palmgren [5]. Their rule states that failure will occur when $\sum n_i / N_i = 1$, where n_i is the number of stress cycles required to cause failure at stress S_i . This rule is probably the simplest so far proposed.

In spite of the increasing importance of the problem of prediction of

fatigue life under random loading very little progress has been made. The primary difficulty is the insufficient knowledge of the material behaviour under complicated and fluctuating stress condition. Fatigue tests are mostly conducted under cyclic loading and a vast amount of data has been accumulated. Thus the problem of fatigue life estimate under random loading is reduced to the problem of correlating the material behaviour under random and simple harmonic loading via the statistical theory of random processes.

The cumulative damage hypothesis makes it possible to relate the time to failure for a structure to the stress pattern to which the structure is subjected. If the stress history is described statistically, the analysis will reveal the time to failure as a random variable. Ideally it is the objective to estimate the probability distribution of the time to failure. However, very few methods exist for obtaining this distribution directly. Indirect methods have been proposed whereby the resulting damage is statistically described. Miles [7] derived an expression for the mean damage and Crandall [8] found an expression for the variance of the damage in the Palmgren-Miner hypothesis.

Miners rule fails to predict the life at failure. Many reasons may be cited for this discrepancy. Tests [38-41] have shown that $\sum n_i / N$ varies with the sequence in which loading is applied, the overall mean stress and whether or not negative stresses are included. It has thus become clear that some improvement of the Palmgren-Miner hypothesis is necessary.

A large number of cumulative-fatigue damage theories have been proposed. In some theories the damage parameters are assumed to be deterministic, but the input or stress history is considered to be random. These are minor variations of the Palmgren-Miner hypothesis [7]. In some theories [26-28] the damage parameters are considered to be random variables. The important physical aspect of the change of material properties has also been accounted for in some theories [23, 24, 33-37].

Some investigators [38-41] have devoted their efforts towards correlating experimentally random loading statistics with the fatigue life of a test specimen. Although these results are acceptable for the particular type of loading tested, they are not general enough to be applied to other types of loading.

Some investigators [22] have experimentally proposed modification factors K to be applied to the slope of the S-N curve. These factors seem to vary somewhat from material to material suggesting that some unidentified property of the material should be included in the expression for cumulative-damage.

In this report a random load fatigue testing procedure is also presented. This could be easily set up and used for verifying some of the theories. Some applications to design problems are also shown.

Due to the recent interest in unifying the Fracture Mechanics and Fatigue Damage theory, a brief review is presented (in Appendix A)

of the 'flaw-propagation' approach to fatigue damage. Appendix B contains a brief review of the Fracture Mechanics theory.

CHAPTER 2

Description of the Random Loading

2.1 Introduction

The problem of determining the stresses and fatigue life from random loading is now receiving attention in the design of structures for which reliability is important, and where failure would lead to great loss of human lives and financial investment. Recent advances in probabilistic analysis [9-10] and in the basic physical concepts [11-17] have rendered possible an approximate analysis of some of the more important features of the problem e.g. determination of the mean and variance of the damage.

In performing the analyses it is usually assumed that the dynamic characteristics of the system are deterministic and the excitation is a random process. The objective is to compute the probability law which governs the behaviour of the random response of the system, or the statistical properties describing the response. From an engineering standpoint the objective is to determine the reliability of the structure to withstand random excitations and to predict its service life.

2.2 Comparison Between Deterministic and Random Loading

In order to distinguish fatigue under simple cyclic loading from that due to cumulative-damage caused by random loading, it is first necessary to understand the difference between the two types of loading.

A comparison between deterministic and random loading may be made by considering figs (2.1) & (2.2). The loading record in fig (2.1A) can be characterised as a sum of sinusoids of different frequencies, fig (2.1C). This type of loading can be easily described mathematically as a sum of sine and cosine functions.

The motion shown in fig (2.2A) is more complex. As there is no obvious pattern in the loading record it is usually called a 'random' loading. Fig (2.2B) shows the components of the random signal after being passed through a set of narrow-band filters. The squared filter outputs are divided by the filter bandwidth so that the components are in terms of the loading magnitude squared per cps. The average value of the squared magnitudes per cps or the mean-square-value (σ^2 /cps) is then plotted to form the spectral density curve or power spectrum as shown in fig (2.2C), where only three frequency components are shown whereas the power spectrum could have an infinite range of frequencies.

It is seen that the deterministic loading can be characterised by its amplitude and frequency: On the other hand the random loading is characterised by an average amplitude, the root-mean-square value, and by a decomposition in frequency indicated by the spectral density. Other statistical parameters e.g. auto and cross correlation functions, may be obtained to further describe the random loading.

2.3 Description of the Random Process

Random loading can be described by a family of random variables,

called a random process. The probability distribution functions are used to describe the random process.

A random process is stationary if its probabilistic structure is unchanged upon a shift of the parametric origin. Thus $X(t)$ and $X(t-a)$ are governed by the same probability distribution functions, where $X(t)$ is the random loading amplitude at time t and a is the time shift.

A random process is weakly stationary if its mean values and covariances are unaffected by a translation of the time origin [18].

In ergodic random processes the ensemble average is always equal to the corresponding average obtained from a single realization and taken over the range of parametric values.

Under the supposition of regularity in the loading sequence, many engineering problems can be solved by considering the loading to be one of the above category of random processes. Since the statistical description of these random processes is available, a description of the response of the system under the loading can be obtained.

2.3.1 Weakly Stationary Excitations

A large number of practical (physical) situations exist where an engineering structure is subjected to a random loading which may be assumed to be weakly stationary. A few examples [11-18] of such situations are described below.

Jet Noise, Buffeting

It has been experienced that a major damage to the aircraft panels occurs during takeoff, when the jet engines are operated at maximum power. Strictly the generated acoustic pressure can not be stationary since the engine power must be gradually built up to the maximum level, as the airplane gains speed, and the level gradually reduced to that required for cruising flight. However, during the maximum engine power run, which lasts from one to two minutes, the generated acoustic pressure measured at a given point on the fuselage or wing structure exhibits a weakly stationary pattern. Therefore for the purposes of fatigue damage estimate, it is justifiable to disregard the non-stationary portion of the excitation, which constitutes only a negligible amount of the total damage.

Automobile On a Highway

The highway may be assumed to possess a roughness which imparts a weakly stationary excitation to the automobile. The automobile may have to slow down or speed up temporarily when following or passing another automobile. But, if only a small percentage of time is spent travelling at varying speeds, then it is permissible to neglect the non-stationary portion of the excitation in assessing the fatigue damage of a structural part of the automobile.

Random Pressure Fluctuation, Atmospheric Turbulence, and Gust Loading

Similar assumptions as above, apply for these cases to approximate the excitations as weakly stationary random processes. Especially for these cases considerable flight data have been assembled in power spectra form [44, 45]. In measuring the data the atmosphere was divorced from the aeroplane by properly instrumenting the aircraft and

correcting for the aircraft motion relative to the ground. The statistical characteristics of the gust velocities are provided by the power spectral density functions. These may be used in determining the stress spectra through dynamic analysis.

2.3.2 Non-Stationary Excitations

In many instances, the excitation on a structure is non stationary, but there seem to be relatively few analyses or experimental studies dealing with such problems. These processes consist of a burst of random excitation which has a significant strength for only a short period of time. In such cases the fatigue damage may be small and it is often more reasonable to consider alternative failure mechanisms. It may be assumed [19] that failure occurs when the response exceeds a specified critical amplitude level and to examine the statistics of such an occurrence. The problem of calculating the probability distribution of the maximum displacement of a system which is subjected to non-stationary random loading is more complex than for the stationary case. The information often required in the analysis is the expectation and covariance functions of the excitation process. These must be estimated by averaging over a large number of sample records. This procedure was used [20] in the landing analysis of a B-24D aeroplane. Earthquakes motion analysis [21] has been conducted by considering the non-stationary excitation as a non-stationary 'shot-noise'.

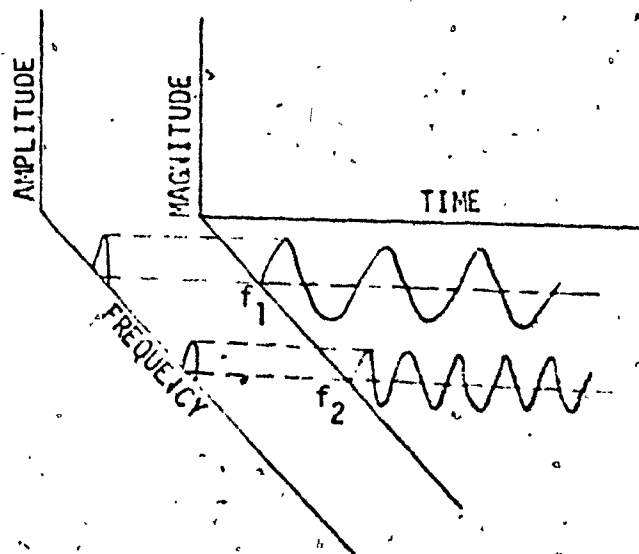
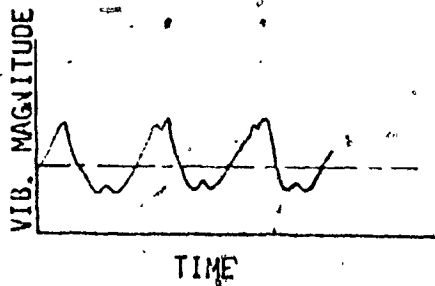

FIG 2.1 ANALYSIS OF PERIODIC LOADING [22]

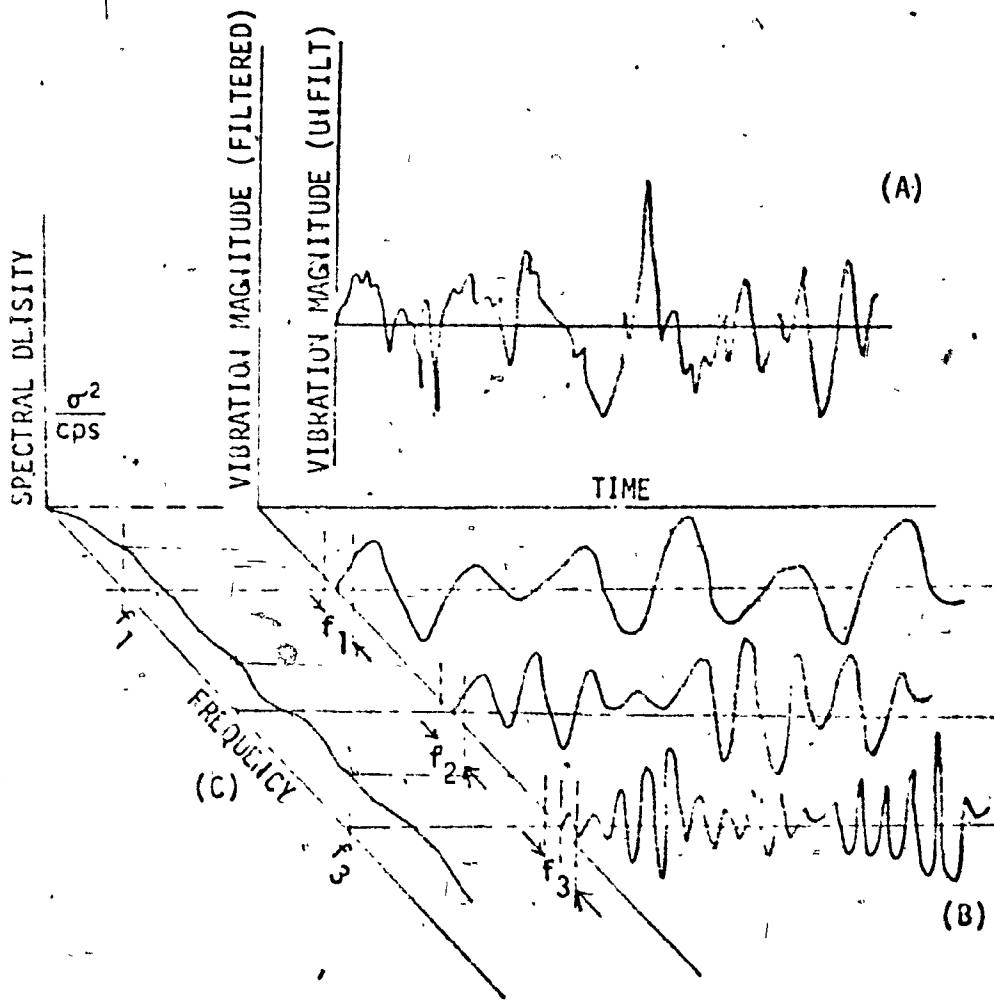

FIG 2.2 ANALYSIS OF RANDOM LOADING [22]

CHAPTER 3

A Review of Theories of Fatigue Damage

3.1 Introduction

Numerous theories have been put forward which account for the fatigue of structures due to random loading. These theories may be classified into:

- 1) Theories in which the damage is assumed to be deterministic and the loading is stationary narrow-band Gaussian [57]. These are merely variations of the Palmgren-Miner Theory.
- 2) Theories in which the damage is considered as a random variable.
- 3) Theories in which the changing material properties during random loading are taken into consideration.

3.2 Theories in which Damage is considered to be Deterministic

The classical Palmgren-Miner hypothesis [4, 5] is based on the following assumptions:

- 1) A simple concept of damage exists. Damage can be expressed in terms of the number of load or stress cycles (n_i) applied divided by the number of cycles (N_i) to produce failure at a given stress level (S_i), i.e. n_i/N_i .
- 2) When the summation of these increments of damage at several stress levels becomes unity, failure occurs.

- 3) The loading cycle is essentially sinusoidal.
- 4) The total amount of work that can be absorbed produces failure. No work hardening occurs.
- 5) The inception of a crack, when observed, is considered to constitute failure.

If W represents the net work absorbed at failure, n_1 the cycles required for failure and w_1 the work done at n_1 cycles

Then:

$$\frac{w_1}{W} = \frac{n_1}{N_1} \tag{3.1}$$

and similarly for w_2, n_2, N_2 etc. and

$$w_1 + w_2 + w_3 + \dots + w_n = W \text{ (at failure)} \tag{3.2}$$

Hence:

$$\frac{w_1}{W} + \frac{w_2}{W} + \frac{w_3}{W} + \dots + \frac{w_n}{W} = 1 \tag{3.3}$$

and substituting values of equation (3.1) into (3.3)

$$\frac{n_1}{N_1} + \frac{n_2}{N_2} + \frac{n_3}{N_3} + \dots + \frac{n_n}{N_n} = 1 \tag{3.4}$$

or:

$$\sum_{i=1}^k \frac{n_i}{N_i} = 1 \tag{3.5}$$

The most frequently used form of Miners rule is in predicting the number of stress or load cycles that can be repeated until failure as:

$$N = \frac{1}{k \sum_{i=1}^k \frac{1}{N_i}} \tag{3.6}$$

The damage is then defined as:

$$D = \sum_{i=1}^k \frac{n_i}{N_i} \quad (3.6a)$$

Miles [7] studied the effect of the fluctuating loads induced by a jet on aircraft structural components. He evaluated the expected or mean value of the damage, by assuming the stress history to be the response of a single degree of freedom system excited by a Gaussian white noise. The S-N diagram of the material, fig (3.1), was expressed mathematically as:

$$n(s) = (s_1 / s)^\alpha \quad (3.7)$$

Where:

s_1 = stress for failure in one complete cycle

s = stress at any cycle

α = slope of the log S - log N curve (fig 3.1)

$n(s)$ = number of complete stress reversals at stress s required to produce a fatigue failure.

Fig (3.1) shows the logarithmic plot of the eqn (3.7). According to Miles although there exists a minimum stress, called the endurance limit, below which fatigue failure never occurs it is reasonable to ignore the existence of the endurance limit. The endurance limit depends on certain beneficial changes in the material produced by alternating stress at a low level. Intermediate excursions to higher stress levels may counteract these changes; moreover it appears only a few materials, notably steel, possess well defined endurance limits.

Substituting eqn (3.7) into eqn (3.6a) the damage D is given by:

$$D = \sum_{i=1}^k n_i (s_i/s)^\alpha \quad (3.8)$$

where $\alpha = 10$ to 25

In calculating the probable fatigue life of a lightly damped structure under random loading, Miles derived an expression for the equivalent stress s_r , which would produce individually the same fatigue damage as the original stress spectrum, due to random loading, as follows.

$$s_r \approx \left(\frac{k \bar{s}^2}{e} \right)^{\frac{1}{\alpha}} \quad (3.9)$$

where:

k = a constant usually between 1 (Miles) and 2 (Shanley [23])

\bar{s}^2 = mean square value of stress.

e = logarithmic exponent.

Miles showed that the determination of the equivalent stress under random loading depends essentially on the root mean square stress produced by the same loading.

Miles approximated his system as a single degree of freedom system and obtained the ratio of the equivalent to static stress as:

$$\frac{s_r}{s_0} = \left[\frac{k \pi \alpha}{4 e \delta} \cdot \frac{\omega_0 f(\omega_0)}{F_0^2} \right] \quad (3.9)$$

where:

δ = damping coefficient.

ω_0 = frequency of oscillation.

$f(\omega_0)$ = power spectral density of the loading.

F_0 = root mean square of the loading.

s_0 = static stress.

Eqn (3.9) is useful in solving a number of problems which may be approximated by a single degree of freedom system. An example is shown in Chapter 5.

3.2.1 Limitations of the Deterministic Damage Theories

Miners rule suffers from the drawback that it uses un-measurable concepts of internal work and damage. Brinbaum and Saunders [24] found that the damage is related to the arrangement of the loading cycles. Since Miners rule does not consider this it may sometimes substantially overestimate the true number of cycles to failure.

The vague concept of damage is in need of reinterpretation in the light of the modern fracture mechanics. Instead of assuming that constant repetition of the same load in each oscillation contributes exactly the same amount of damage, it appears more reasonable to consider that the damage might vary from one oscillation to the other. Hence it should be assumed that the total damage at failure is a random variable which can assume different values for different specimens of the same material. Miners assumption that the damage produced in the j^{th} oscillation is linearly additive to the damage sustained in the $(j-1)^{\text{th}}$ oscillation does not seem justified.

3.3 Theories in which the Damage is Considered as a Random Variable

Crandall, Mark and Khabbaz [8] extended Miles theory by obtaining both the mean and the variance of the damage. Although they did not start by assuming the damage to be a random variable their end result showed the damage as a random variable. They used two methods, one which took into account the randomness in the amplitudes and the periods, and the other neglecting the randomness in the periods.

Crandall considered the total damage D as the sum of incremental damages d accrued during incremental time intervals i.e.

$$D = \sum_{i=0}^{M-1} d_i \quad (3.10)$$

where M is the number of subintervals in total time T .

The mean and variance of D are:

$$E [D] = \sum_{i=0}^{M-1} E [d_i] = M E [d_0] \quad (3.11)$$

where d_0 is damage in any sub-interval.

Since the stress history is assumed stationary, the damage process is also stationary. Hence:

$$\begin{aligned} \text{var} [D] = M \{ E[d_0^2] - (E[d_0])^2 \} + 2 \sum_{l=1}^{M-1} (M-k) \{ E[d_0 d_k] \\ - (E[d_0])^2 \} \end{aligned} \quad (3.12)$$

where $k = j-i$ denotes arbitrary sub-interval difference.

var \Rightarrow variance

In the Palmgren-Miner hypothesis the damage d_i is given as $1/N_i$.

However, Crandall et al consider the damage d_i as the damage per half

cycle namely $d_i = 1/2N_i$. The expression for the expected frequency ω_0 for a Narrow Band Stationary Gaussian process was derived by Rice as:

$$\omega_0^2 = \frac{\int_{-\infty}^{\infty} \omega^2 S(\omega) d\omega}{\int_{-\infty}^{\infty} S(\omega) d\omega} \quad (3.13)$$

where $S(\omega)$ is the spectral density of the process, and ω_0 is the expected frequency.

Using the above relationship Crandall obtained the stress amplitude s as:

$$s = \frac{|\dot{s}|}{\omega_0} \quad (3.14)$$

where s is the slope of the stress amplitude function at the crossing point with the zero axis.

Hence N may be obtained from s through the relationship of the S-N curve, eqn (3.7). Now dividing the total interval $(0, T)$ into small sub-intervals of length Δt , it follows that only for those sub-intervals for which there is an axis crossing will there be damage. Thus Crandall obtained the expected damage for an interval of length Δt to be given by:

$$E[d_0] = \int_{-\infty}^0 \frac{1}{2N} ds \int_0^{-s\Delta t} P(s, \dot{s}) ds + \int_0^{\infty} \frac{1}{2N} ds \int_{-s\Delta t}^0 P(s, \dot{s}) ds \quad (3.15)$$

If $S(t)$ is a Gaussian process, it follows that:

$$P(0, \dot{s}) = \frac{1}{\sqrt{2\pi} \sigma_s^2} e^{-\dot{s}^2 / 2\sigma_s^2} \quad (3.15a)$$

where σ_s^2 is the mean square value of \dot{s}

Substituting eqn (3.13) into the S-N relation yields:

$$\frac{1}{2N} = \frac{1}{2} \left(\frac{|\dot{s}|}{\omega_0 S_1} \right)^\alpha \quad (3.16)$$

Using these results:

$$E [d_o] = \Delta t \cdot \frac{\omega_0}{2\pi} \left(\frac{\sqrt{2c_s}}{s_1} \right)^\alpha \Gamma \left(1 + \frac{\alpha}{2} \right) \quad (3.17)$$

where Γ defines Gamma function.

Substituting eqn (3.16) into (3.11) and letting M become large so that $M\Delta t \approx T$, the mean or expected damage for an interval was obtained as:

$$E [D(T)] = \frac{\omega_0}{2\pi} T \left(\frac{\sqrt{2c_s}}{s_1} \right)^\alpha \cdot \Gamma \left(1 + \frac{\alpha}{2} \right) \quad (3.18)$$

Upon making further assumptions that the exponent is an odd positive integer and letting $t \rightarrow 0$ and $k\Delta t = \tau$, Crandall obtained the variance of the total damage as:

$$\begin{aligned} \text{var} [D(T)] &= \frac{\omega_0 T}{4\pi} \left(\frac{2c_s^2}{s_1^2} \right) \Gamma(1+\alpha) \\ &+ 2 \left(\frac{2c_s^2}{s_1^2} \right)^\alpha \left(\frac{\Gamma(1+\frac{\alpha}{2})}{2\pi} \right)^2 \int_0^T \omega_0 (T-\tau) \\ &\left(\frac{\Lambda^{\alpha+3/2}}{\omega_0^{2\alpha+2} \sigma_s^{2\alpha} \Lambda^{2\alpha+2}} F \left(1 + \frac{\alpha}{2}; 1 + \frac{\alpha}{2}; \frac{1}{2}; \frac{\Lambda^2 2\tau}{\Lambda^2 22} \right) - 1 \right) d\tau. \end{aligned} \quad (3.19)$$

Where the Λ - parameters depend on the autocorrelation of the stress process and are evaluated separately. Eqn (3.17) is identical to Miles result. An example of the application of Crandalls theory is presented in Chapter 5.

Gumbal [27] observes that the number of stress applications required to produce fatigue failure is a random variable. That is, for a collection of apparently identical specimens even under closely controlled experiments the spread in the number of load cycles to produce failure is too great to be attributed to experimental error. It is thus concluded that there is a physical phenomenon being observed. As a result a number of mathematical models have been proposed in order to predict a theoretical distribution function for the number of cycles to failure $N(s)$ at a given stress level s . These models determine the failure distribution:

$$P_s(n) = \text{Prob} (N(s) \leq n) \quad (3.19)$$

or, equivalently, the survival function.

$$L_s(n) = 1 - P_s(n) = \text{Prob} (N(s) > n) \quad (3.20)$$

The models proposed may be summarized as follows. (Murphy [28] Kozin [26])

A. The Log-Normal Distribution

The sequence $D_1(s), \dots, D_n(s)$ is assumed to be a sequence of random variables that represent the amount of damage accumulated at each successive load application at stress level s . The basic assumption is that the damage at the n^{th} load application is related to its predecessor as:

$$D_n(s) - D_{n-1}(s) = \epsilon_n D_{n-1}(s) \quad (3.21)$$

where ϵ_n is the random effect due to the n^{th} load application and (ϵ_i) is a sequence of independent random variables. It follows from eqn (3.21) that

$$D_n(s) = (1 + \epsilon_n) D_{n-1}(s) = (1 + \epsilon_n) \dots (1 + \epsilon_1) D_0 \quad (3.22)$$

It is noted from eqn (3.22) that the logarithm of $D_n(s)$ is the sum of a large number of independent terms containing ϵ_n . If the independent random variables satisfy the central limit theorem, it implies that the $\log D_n(s)$ is approximately normal for n large. Hence, $D_n(s)$ is approximately log-normal when n is large. From further reasoning it also follows that the number of cycles to failure $N(s)$ is log-normal. The probability density and mean values are thus known.

B. Extreme Value Distribution - First Asymptotic Form

The material is assumed to be made up of fibres or very thin rods.

The assumption is made that the damage to this material is equivalent to the snapping of fibres in this bundle. The properties of the fibres are assumed to be independent of one another, and each distinct fibre can withstand a number $N(s)$ of load applications at stress level s applied to the entire bundle. The number $N(s)$ is a random variable distributed according to the distribution $F_s(n)$ i.e.;

$$\text{Prob } \{N(s) \leq n\} = F_s(n) \tag{3.23}$$

Failure is considered to occur when all the fibres have failed.

The probability that the material survives n cycles at stress level s with M fibres in the bundle is given as:

$$1 - [F_s(n)]^M \tag{3.24}$$

The associated density function is:

$$f_s(n) = \frac{d(1 - [F_s(n)]^M)}{dn} = -M[F_s(n)]^{M-1} \frac{dF_s(n)}{dn} \tag{3.25}$$

Eqn (3.25) is merely the probability density for an extreme value distribution of a collection of M independent samples. For $M \rightarrow \infty$ [27] gives the probability distribution and density functions of

$$[F_n(n)]^M.$$

C. Extreme Value Distribution - Weibull Distribution

Murphy [28] describes the physical assumptions leading to the above distribution to be the same as for case (B), extreme value distribution, except that the system fails if any one fibre fails. The probability that none of the fibres has failed in n applications of the load at stress level s is given by:

$$[1 - F_s(n)]^M \tag{3.26}$$

The probability density function for survival is given by:

$$f'_s(n) = -M [1 - F_s(n)]^{M-1} dF_s(n) / dn \tag{3.27}$$

Again as $M \rightarrow \infty$, $1 - [1 - F_s(n)]^M$ approaches the Weibull distribution [31].

According to Kozin the preceding three failure distributions (A), (B) & (C) constitute the most commonly used distributions in the study of failure under random load applications at a given stress level.

Another random fatigue damage model is presented by Parzen [29]. He assumes that the damage $D(s)$ associated with the stress level s is a random variable, and considers that the damage at each successive application is independent of any other application. Furthermore the successive damages at each application are identically distributed. The total damage accumulated after N stress applications is given by the sum

$$D_1(s) + D_2(s) + \dots + D_N(s) \tag{3.28}$$

Parzen assumes that the material specimen can accumulate a total amount of damage D . At stress s the total number of cycles to failure of a specimen of strength D are $N_D(s)$. Thus failure is denoted by the simple first passage situation when total damage exceeds D . Parzen recognizes that his cumulative damage model is a stationary renewal counting process due to Smith [30]. Thus using the basic limit theorems of renewal theory Parzen determined the expected value and the variance of the damage as:

$$E\left\{\frac{D(s)}{D}\right\} = \frac{1}{E\{N_D(s)\}} \quad (3.29)$$

$$\text{var} \frac{D(s)}{D} = \frac{\text{var}\{M_D(s)\}}{[E\{N_D(s)\}]^3} \quad (3.30)$$

where: $\frac{D(s)}{D}$ = the portion of damage on a given cycle.

$$M_D = E\{N_D(s)\}$$

3.3.1 Discussion of the Random Damage Theories

A number of mathematical difficulties exist in the derivation of random damage theories. Some are associated with the definition of the zero axis crossing and the statistical properties of the stress history. Approximations have been used in many instances to simplify the problem. Crandall used the narrow band assumption to obtain an 'average frequency' from which the maximum amplitude was obtained from the slope at the zero axis crossing.

Parzen [31] gave a useful concept of a hazard function, $\mu(x)$. This is the conditional failure density function given as:

$$\mu(x) dx [1-F(x)] = f(x) dx \quad (3.31)$$

where $F(x)$ is the failure distribution, which from further reasoning is given as⁴

$$F(x) = 1 - \exp \left[1 - \int_0^x \mu(x) dx \right] \quad (3.32)$$

Kozin uses the hazard function to study the failure probabilities (A), (B) & (C) presented in section 3.3. Obviously since the fatigue process is defined as a process of progressive damage terminated by actual failure, it follows that the hazard function will be an increasing function of the number of cycles sustained without failure by the material. Such a property is possessed by the extreme value distribution, (B) & (C). However the log-normal distribution possesses a hazard function which has a very slow asymptotic approach to zero after a reasonable sharp rise to a maximum value. Because of this characteristic the log-normal distribution is not generally preferred. Freudenthal [32] prefers the Weibul distribution due to its hazard functions agreement with material behaviour. Also it shows that there will be no failure below a threshold of load level, which is in agreement with practice.

Kozin however does not seem to favour any of the distributions A, B or C. He feels that in many of the arguments presented the physical picture seems secondary to arithmetic simplicity. Kozin prefers Parzens [29] model for cumulative damage, where in order to determine the mean values one must know the statistics of the environment. Such data is available in many cases such as turbulence, gust loads and various vibration load environment encountered from acoustic noise sources etc. Furthermore Parzens approach enables one to obtain the

mean and variance of the damage without first requiring assumptions concerning the nature of the distribution of the number of cycles to failure. However several assumptions have been made in his model one of which is the postulation that the damage distribution for different load levels is identical. This may not be necessarily so.

3.4 Theories in which the Changing Material Properties are Considered

Kozin [26] states that in the formulation of a fatigue damage theory any argument that omits the history of the stress function and neglects the fact that each time a material is cyclically stressed its properties change, (implying a non-stationarity of the fibre strength distribution); the fundamental physical phenomenon of fatigue failure is ignored. This is the case with the 'static' theories presented so far.

Freudenthal and Heller [33] were the first to make an attempt to incorporate the material properties by modifying the Palmgren-Miner rule. According to this rule failure occurs when,

$$\sum_i^n P_i N_i \cdot 1/N_{si} = 1 \tag{3.33}$$

Freudenthal and Heller replace eqn (3.33) by:

$$\sum_i^n P_i N_i \cdot (w_i / N_{si}) = 1 \tag{3.34}$$

where w_i are 'stress interaction' factors that depend upon all other amplitudes and number of cycles present at each amplitude, as well as their order of occurrence. These factors are determined experi-

mentally for a variety of input stress functions. These factors are however not general enough since they cannot be derived analytically.

Gatts [34, 35] attempts to base fatigue failure on the known stress strain relationship accounting for the changing material properties. He uses the concept of strength and the stress strain hysteresis loop, to develop his theory. Gatts considers that the two material strengths, viz the endurance limit and the failure stress should be measures of the damage due to a given stress. Obviously no damage occurs until the stress amplitude exceeds the endurance limit and failure stress. He expresses these postulates mathematically:

$$dS_f(n) / dn = - KD (S(n), S_e(n)) \quad (3.35)$$

where:

n = the number of cycles.

$S(n)$ = the applied stress.

$S_e(n)$ = the endurance limit.

$S_f(n)$ = the failure stress.

K = a const > 0

Also:

$$D(s(n), S_e(n)) = 0 \text{ for } S \leq S_e \quad (3.35a)$$

The boundary conditions for eqn (3.35) are:

when

$$n = 0, \quad S_e = (S_e)_0$$

$$n = N, \quad S_f = S(n)$$

Gatts approach is in fact too general, and a number of other assumptions are required to obtain specific results. The important variable is

the unknown function D . Gatts considers the shaded portion of the straight line stress strain hysteresis loop, Fig 3.2. This gives the irreversible work input into the material and is proportional to $(s - s_e)^2$. Hence eqn (3,35) becomes

$$\frac{ds_f(n)}{dn} = \begin{cases} -k' (s(n) - s_e(n))^2, & s > s_e \\ 0, & s \leq s_e \end{cases} \quad (3.36)$$

Since two more unknown functions s_e , s_f remain to be defined Gatts proposed a doubtful hypothesis, that is that s_e/s_f is a constant. With further assumptions to overcome mathematical difficulties the final result is obtained as:

$$E \{ s_e(n+1) \} = E \{ s_e(n) \} - KE \left\{ \int_{s_e(n)}^A [s - s_e(n)]^2 dP(s) \right\} \quad (3.37)$$

Kozin feels that Gatts attempt to base a cumulative damage theory upon the changing material properties is truly a step in the right direction, however he does not seem to agree with the assumption of constant s_e/s_f .

Henry [36] presented a theory that considers changes in the endurance limit and other material properties as fatigue damage increases.

Valluri [37] proposed a hypothesis of fatigue damage based upon certain features of the dislocation theory combined with elastoplastic analysis of the stress distribution near a crack. These theories and a number presented by others have only minor variations from the original theme. They mostly propose correction factors, to be applied to the Palmgren-Miner cyclic ratios, which are determined experimentally.

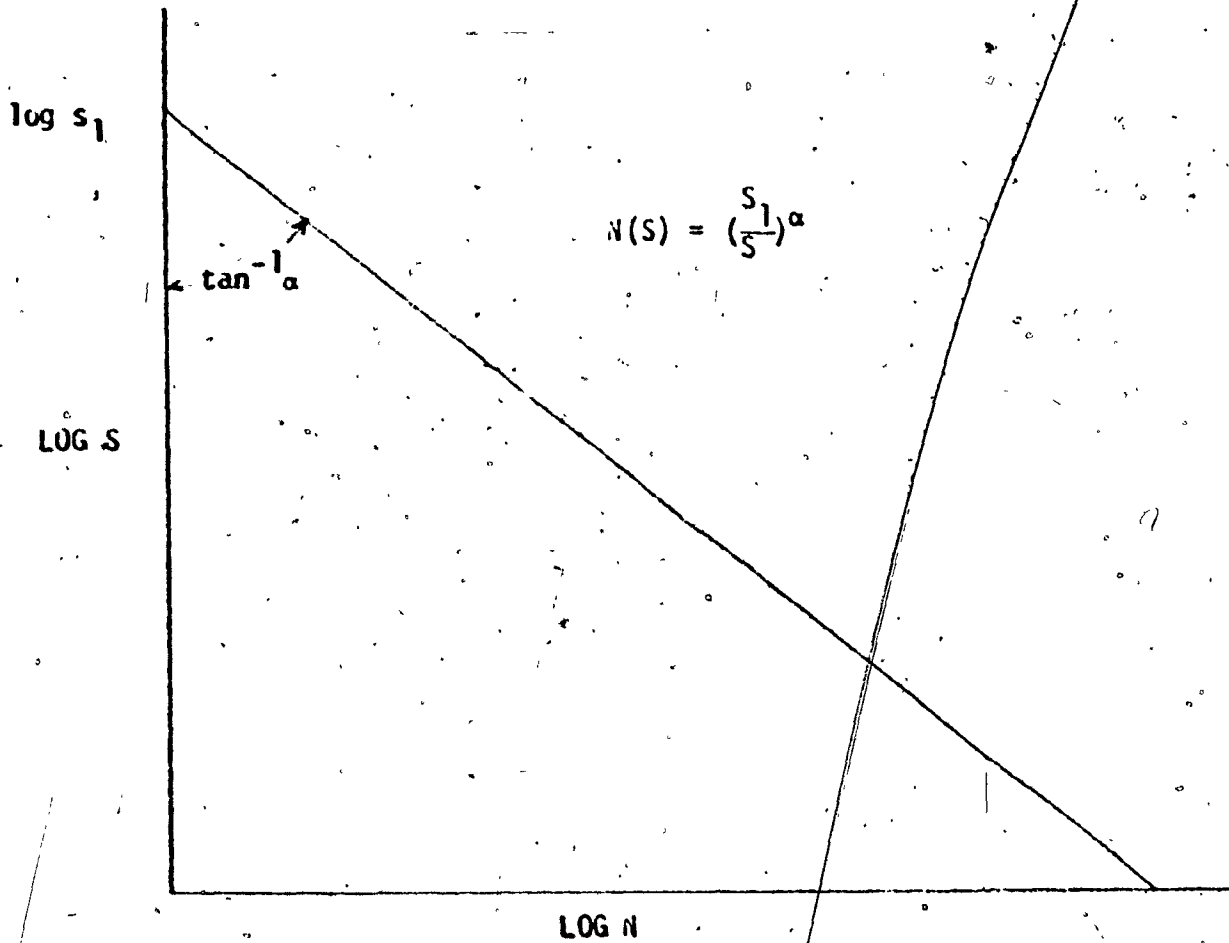

FIG 3.1 LOGARITHMIC PLOT OF TYPICAL S-N CURVE [7]

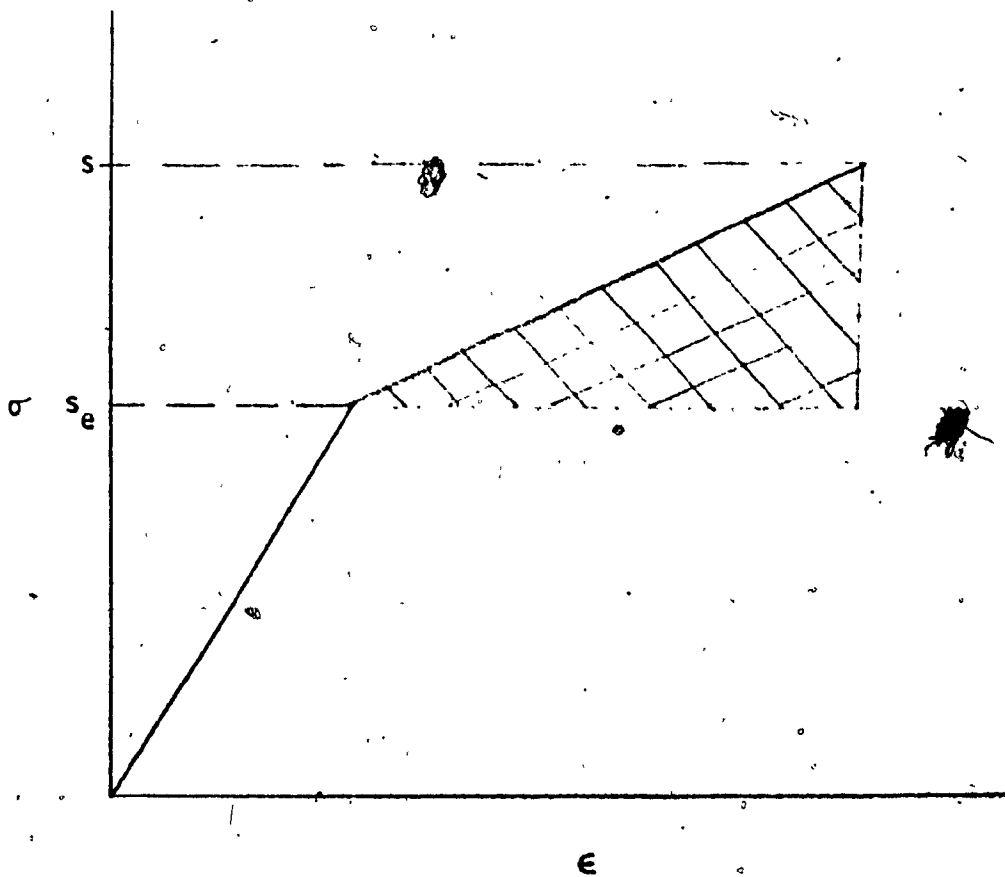

FIG 3.2 STRESS STRAIN HYSTERESIS LOOP [35]

CHAPTER 4

A Random Load Fatigue Testing Procedure

4.1 Introduction

Experimental work plays an important role in the study of fatigue damage. Although there are a number of theories of failure the literature on the testing under random environment is scanty. A random load fatigue testing procedure is presented, which could be used to study the theories of random fatigue damage.

4.2 Determination of the Service Loading

Of the various engineering structures, the aircraft structures have been subjected to systematic observations to determine an estimate of the flight loads and their relative frequency of occurrence [43-46]. An analysis of these data has led to the conclusion that the relative frequency distribution $p(s)$ of flight loads, as a first approximation, can be presented by an exponential distribution:

$$P(s) = c e^{-c(s-s_0)} \quad (4.1)$$

where:

s = load

s_0 = lower limit of the loads.

c = measure of the decrease in the frequency of loads with the increase in their amplitude.

The probability of a load amplitude higher than s is:

$$P(s) = \int_s^{\infty} P(s) ds = \int_s^{\infty} c e^{-c(s-s_0)} ds = e^{-c(s-s_0)} \quad (4.2)$$

The probability of a load amplitude between the limits s_k and s_{k-1} is:

$$P(S_{k-1}, k) = P(S_{k-1}) - P(S_k) = p_k \quad (4.3)$$

Eqn (4.2) shows that if $(s_n - s_0)$ is large, where s_n is the maximum load, the probability $P(s_n)$ becomes extremely small. Since $p(s)$ theoretically extends from s_0 to ∞ , there is no loss of accuracy if the range is limited to s_0 to s_n . If $(s_n - s_0)$ is divided into n equal intervals, the probability of occurrence of load amplitudes within the k^{th} interval is given by, p_k , eqn (4.3). Thus the varying load amplitudes within the interval between s_{k-1} and s_k may be replaced by the mean amplitudes of this interval $s_{k-1, k}$. Hence the continuous distribution function $p(s)$ may be represented approximately by n discrete probabilities of occurrence p_k (the k^{th} probability, eqn 4.3) of the n load amplitudes $s_{k-1, k}$. This process is shown in fig 4.1A and 4.1B.

It is easy to devise a load program which represents the assumed statistical distribution of the flight loads as given by eqn (4.1). If the loads are drawn at random and the sequence recorded, this would represent a random time series of n load amplitudes. A fatigue specimen subjected to a time series of load amplitudes may be assumed to sustain a load program as representative of actual service conditions.

Each population from which the time series is constructed is charac-

terized by the parameters s_0 and c . If the probability of the highest load P_n is specified, the value of c can be easily determined. The value of s_0 would be chosen from experience. In this manner a number, say three, of random time series of load amplitudes may be constructed. These would differ in the specified frequency of occurrence of the most severe load.

4.3 Random Fatigue Testing Machine

A simple fatigue testing machine has been described by Freudenthal [38, 39]. This machine, fig (4.2), imposes a random time series of load amplitudes on a high speed rotating beam fatigue specimen. It operates on the principle of the conventional rotating beam fatigue testing machine with the added feature that the force acting on the rotating cantilever specimen can be arbitrarily varied to conform to a specified load program.

4.3.1 Loading Sequences and Relays

The load sequence is recorded by punching a paper tape of such length that the periodicity of the load sequence can be neglected.

The reading device for the punched tape has been designed for $n = 6$ force levels s_{k-1}, k , according to six lines on the tape along which holes are punched representing the random impulses on any of the six force levels. As the punched holes pass the reading head of the reading device, a system of relays are activated. These are either open

or closed by signals transmitted to them from the tape. The load intensities are controlled by six potentiometers. Thus a sequence of current pulses of variable magnitude are delivered to the moving coil of the loading machine. A schematic of the relays is shown in fig (4.3).

A control circuit for a shock loading machine was developed by Srinivasan and Rau [43]. A similar circuit could be designed for this machine. The reading device thus transmits the loading sequence in the form of current pulses to the fatigue machine. The changes in the current are transformed by the strong electromagnet, in the loading machine, into a sequence of vertical force impulses. Thus the bending moment applied on the specimen follows the force program punched on the tape. The intensity of each of the force pulses from the electromagnet are varied by adjusting the current through the potentiometers. A mechanical counter driven from the main shaft by a worm gear indicates the number of revolutions of the specimen. The traveling speed of the tape and the speed of rotation of the specimen can be adjusted to give a wide range of the number of constant load cycles applied during the passage of one punched hole.

4.4 Random Fatigue Testing and Results

In random fatigue tests the scatter of the test results must be considered to be of primary significance. Hence each test conditions specified by a random time series of loadings, derived from the probability function of load amplitudes, must be repeated frequently

enough to permit a valid statistical interpretation of the results. Freudenthal recommends that at least 25 repetitions of each test condition may be necessary to determine the type of distribution function, extreme value, log-normal etc., which may apply to the test results.

Since a comparison between the results of random fatigue tests and results of the conventional constant amplitude fatigue tests would be of interest, the random tests should be conducted on a material for which the results of constant amplitude tests are available. A typical S-N diagram for such a material would be as shown in fig (4.4). This could be used to select the load distribution s_0 to s_n at say 6 points as shown in fig (4.4). These cover the most significant portion of the S-N diagram.

The test results for each condition should be statistically analysed to give the mean life \bar{n} . The damage hypotheses may be checked by computing the cycle ratios as:

$$\bar{n} = \sum P_k / N_k \quad (4.4)$$

The discrepancy between constant amplitude and random loading testing may be checked by computing the mean stress for each distribution as:

$$\bar{s} = \sum (P_k \cdot S_{k-1, k}) \quad (4.5)$$

The equivalent mean constant stress s_c for each distribution can be determined by reading off from the S-N diagram the stress levels associated with the mean life values \bar{n} .

4.5 Effect of Assumptions and Errors

This random fatigue testing procedure is not limited to the assumption of the exponential distribution of the service loads. The random time series may be derived from any type of specified statistical population. Some load investigations [46] have indicated that a skew distribution function of service loading, with a mode not at but above the lowest load level (extreme value distribution function), provides a closer approximation to certain type of loadings such as gust loads.

Freudenthal states that in his fatigue testing machine, the change of the bending moment due to inaccuracy in the setting and operation of the resistances controlling the current and due to current fluctuations does not exceed $\pm 1\%$. The tolerance of stress, on the fatigue specimen, above its nominal value due to both moment change and slight inaccuracies in the dimensions does not exceed $\pm 1.5\%$. These experimental accuracy claims seem to be improbable. A value of $\pm 5\%$ seems to be more justified. Considering the random nature of the tests this would be difficult to measure.

The complete design and development of this fatigue testing machine and associated hardware is recommended for future research. This equipment should be used to verify the fatigue failure theories under random loading that are being put forward from time to time.

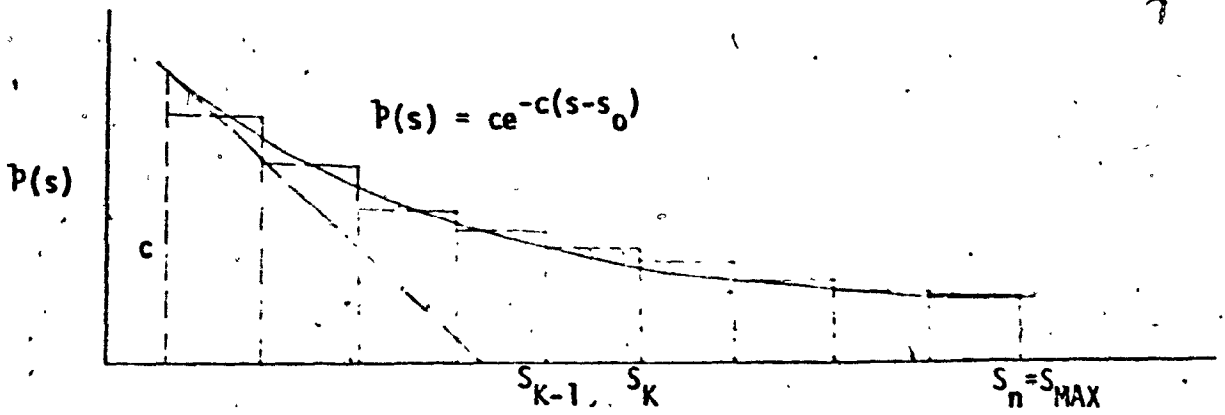

FIG 4.1A

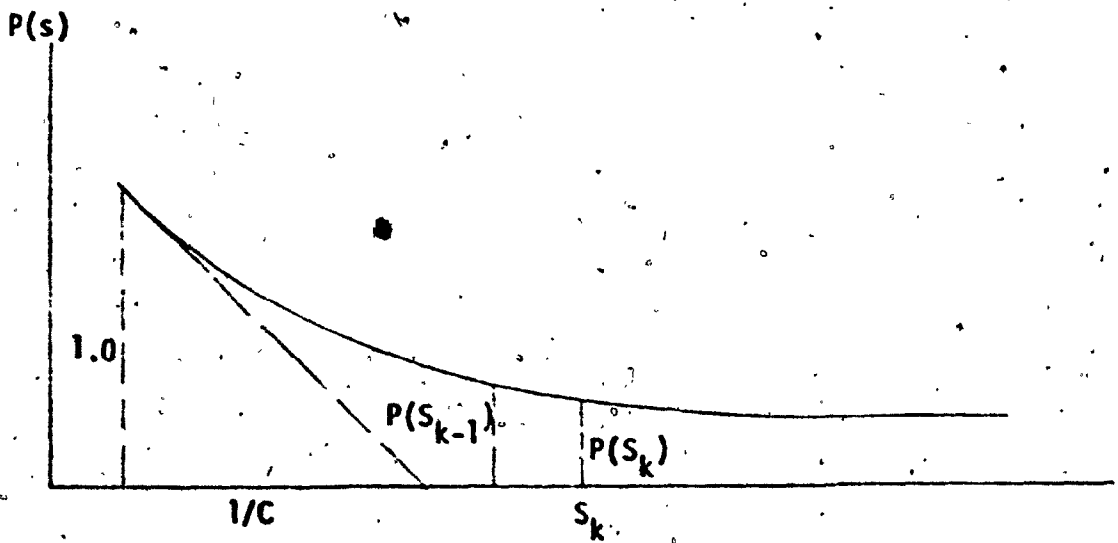
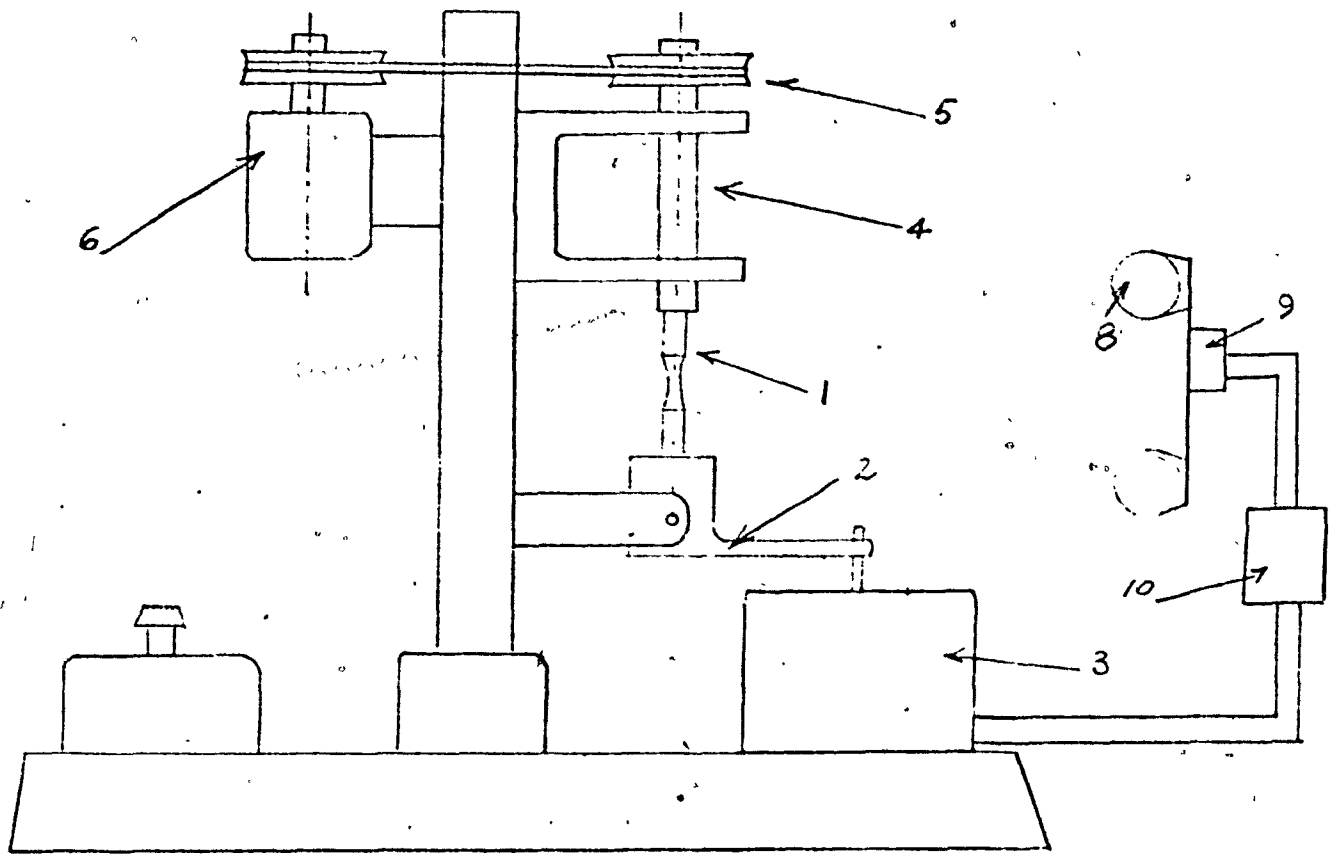

FIG 4.1B PROBABILITY DISTRIBUTION OF LOADS



- | | | |
|---------------------|----------------------|--------------------|
| 1 - SPECIMEN | 5 - PULLEY | 9 - READING DEVICE |
| 2 - LEVER | 6 - MOTOR | 10 - RELAYS |
| 3 - LOADING MACHINE | 7 - SPEED CONTROLLER | |
| 4 - COLLET | 8 - TAPE | |

FIG 4.2 SKETCH OF FATIGUE TESTING MACHINE

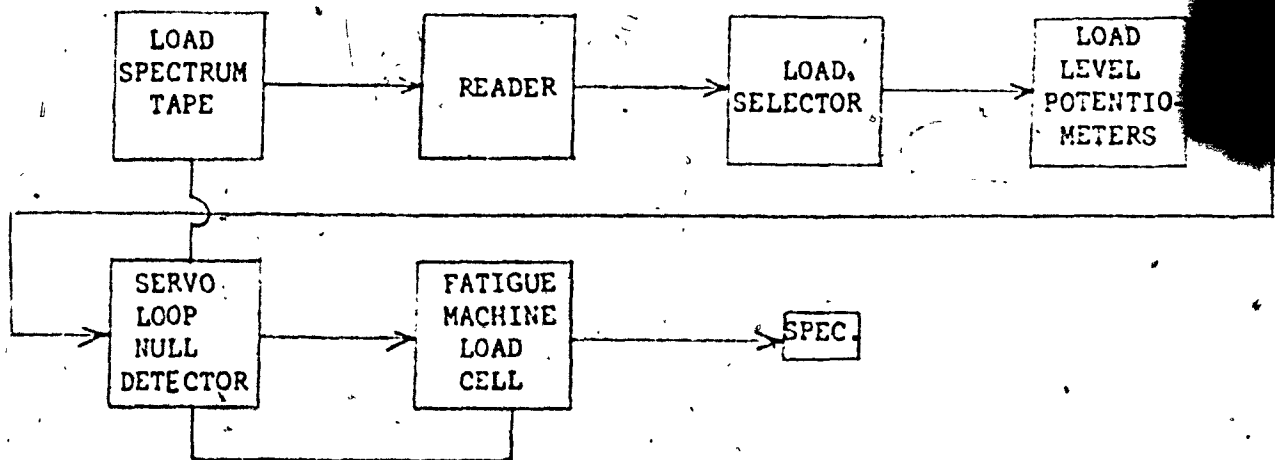

FIG 4.3 SCHEMATIC OF LOADING RELAYS

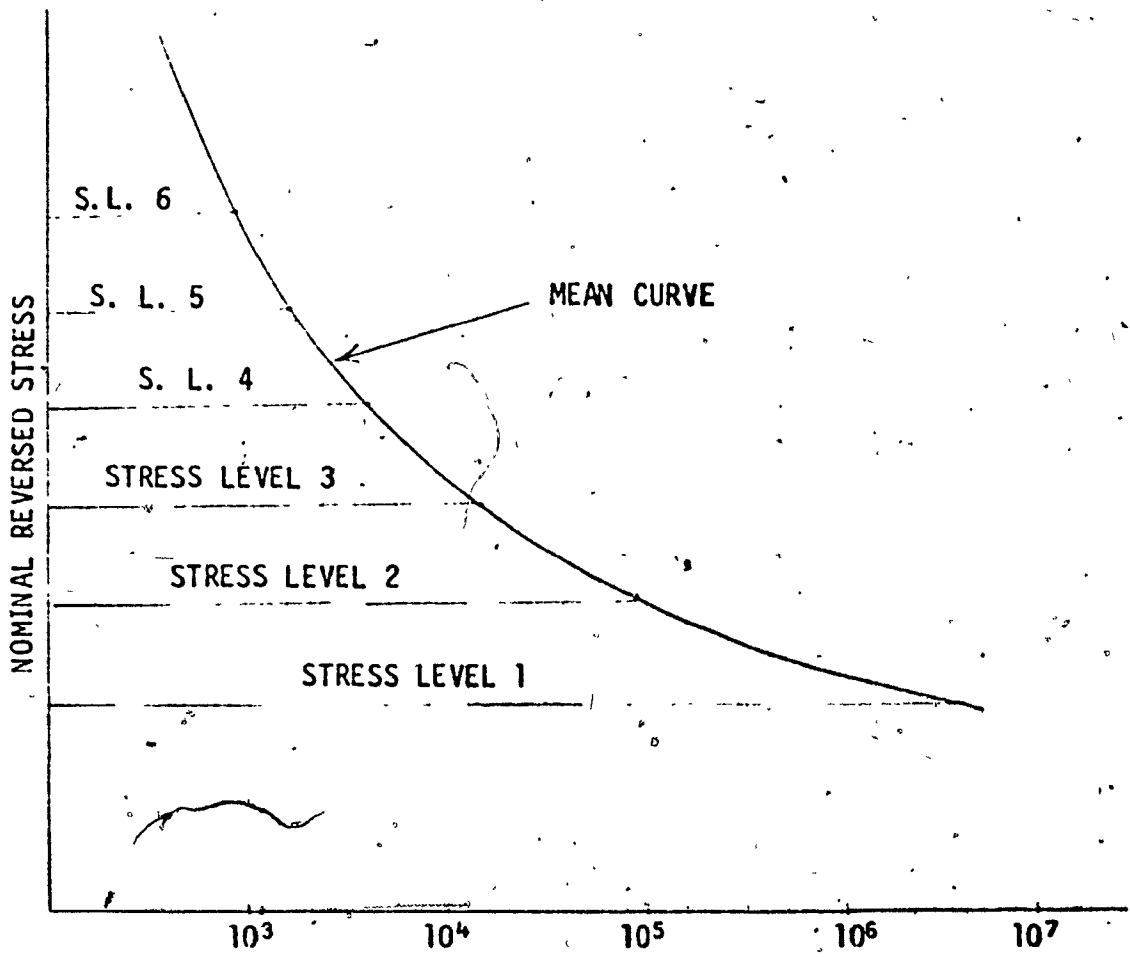

FIG 4.4 TYPICAL S-N DIAGRAM

CHAPTER 5

Applications To Design Problems

Some examples of the applications to structural design of the fatigue damage theories are presented below. Miles [7] and Crandall [8] have considered stationary loading. Robert [19] has presented an application of estimating the fatigue life of structures when subjected to a non-stationary random loading process. Only stationary loadings are discussed here.

Miles appears to have been the first to propose a systematic procedure for determining stresses resulting from random loading and the consequent possibility of fatigue failure. His investigation was prompted by the possibility of an aerospace vehicle panel failure under the fluctuating pressure (i.e. buffeting) of a jet exhaust. Miles model is shown in fig (5.1).

Since measurement of the root mean square stress in the panel may not be practicable, Miles proposes to formulate an approximate similarity expression for the equivalent stress. He uses the results of Lighthills theory [14] of aerodynamic noise generation. The variation of the root mean square pressure is given as:

$$\sqrt{(p - p_0)^2} \sim (U/a_0)^4 (d/x)p_0 \quad (5.1)$$

Where U is the jet velocity, d a characteristic length (e.g. the jet diameter), x is the distance from the source to the panel and a_0 is the sonic velocity in this medium. The static stress s_0 in the thin

panel of thickness h and area A is given by:

$$S_0 \sim \sqrt{(P - P_0)^2} \left(\frac{A}{h^2}\right) \sim \left(\frac{U}{d_0}\right)^4 \left(\frac{d}{x}\right) \left(\frac{A}{h^2}\right) P_0 \quad (5.2)$$

The panel resonant frequency is given by:

$$\omega_0 \sim (h/A) (gE/\rho)^{1/2} \quad (5.3)$$

While the characteristic frequency of the jet may be approximated by:

$$\omega_1 \sim U/d \quad (5.4)$$

whence

$$(\omega_0/\omega_1) \sim (hd/A) (gE/\rho U^2)^{1/2} \quad (5.5)$$

Miles approximates the power spectral density as:

$$f(\omega) = (4F^2/\sqrt{\pi\omega_1}) (\omega/\omega_1)^2 e^{-(\omega/\omega_1)^2} \quad (5.5a)$$

Using the results of his theory Miles, determining the ratio of the equivalent stress s_r with the static stress s_0 , presents the following expression for s_r .

$$\frac{s_r}{P_0} = C_1 \left(\frac{k\alpha}{\delta}\right)^{1/2} \cdot \left(\frac{gE}{\rho a_0}\right)^{1/2} \cdot \left(\frac{d^2}{A^2 h^2 x}\right) \left(\frac{U}{a_0}\right) \times \exp[-C_2 \cdot \left(\frac{gE}{\rho U^2}\right) \left(\frac{hd}{A}\right)^2] \quad (5.6)$$

Having s_r , $N(s_r)$ is calculated using eqn (3.7). The fatigue life is then given by $N(s_r) \cdot T_0$, where T_0 is the period of the mode.

In eqn (5.6) C_1 and C_2 are undetermined positive constants. Miles proposes that C_1 & C_2 may be suitably evaluated to account for the short-comings of his theory. The major drawbacks may be summarized as follows:

1) Approximation of a continuous structure with an infinite set of

- resonant frequencies, by a single degree of freedom model:
- 2) The cumulative damage hypothesis.
 - 3) Omission of the phase effect in determining the loading.
 - 4) Neglect of directional and Reynolds Number effect in the description of the jet noise.

Crandall considers the system shown in fig (5.2 A & B). The vehicle has a stationary random acceleration with uniform spectral density of $0.5 \text{ g}^2/\text{cps}$. The natural frequency of the system is:

$$\omega_n = 465 \text{ rad/sec} \quad (73.9 \text{ cps})$$

The rms stress level of the narrow band stress response in the extreme fibres at the root of the cantilever is:

$$c_s = 2320 / \sqrt{\zeta}$$

where ζ is the damping in the system. Crandall determines the expected value and the standard deviation of the damage as functions of ζ and T . The results are shown in fig (5.3) for four different values of system damping. The expected damages appear as straight lines with unit slopes indicating linear growth with time. The variance in the accumulated damage is suggested by the curves showing $E[D] \pm \sigma_D$.

It may be noted here that the primary effect of the damping is through its action in setting the rms stress level, while a secondary effect is its action in controlling the deviation of the damage through the correlation of the damages of successive cycles.

The Palmgren-Miner criterion for failure is $D = 1$. Fig (5.3) indicates that when the average damage reaches unity there is actually a redistribution of damage across the ensemble of sample histories. Crandall

states that consequently there will be a distribution of time to failure T_F , but this distribution is unknown. However, it is seen that when the stress is of narrow band the variance of the total damage σ_D^2 is small near the time of failure. Therefore it is reasonable to expect that the time duration $T_1 = 1/E [D]$ is close to the expected fatigue life for a narrow band random stress, and it serves as a useful measure in making design decisions.

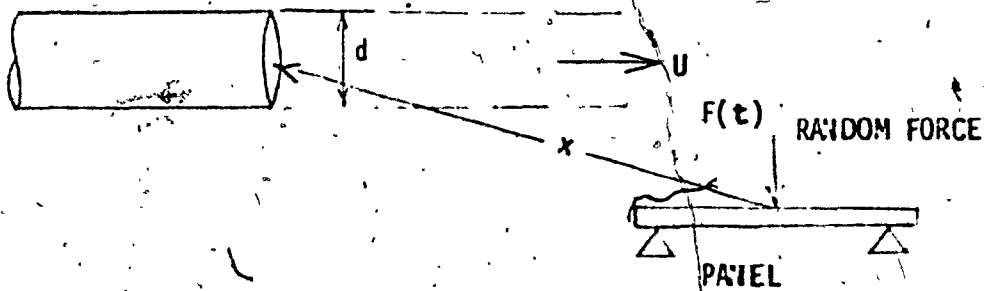

FIG 5.1 MODEL FOR JET EXHAUST LOADING ON PANEL [7]

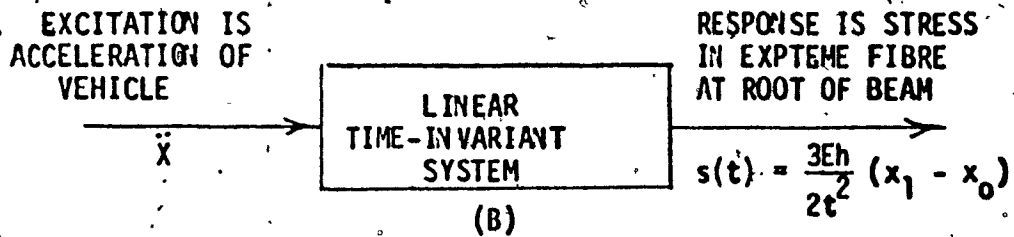
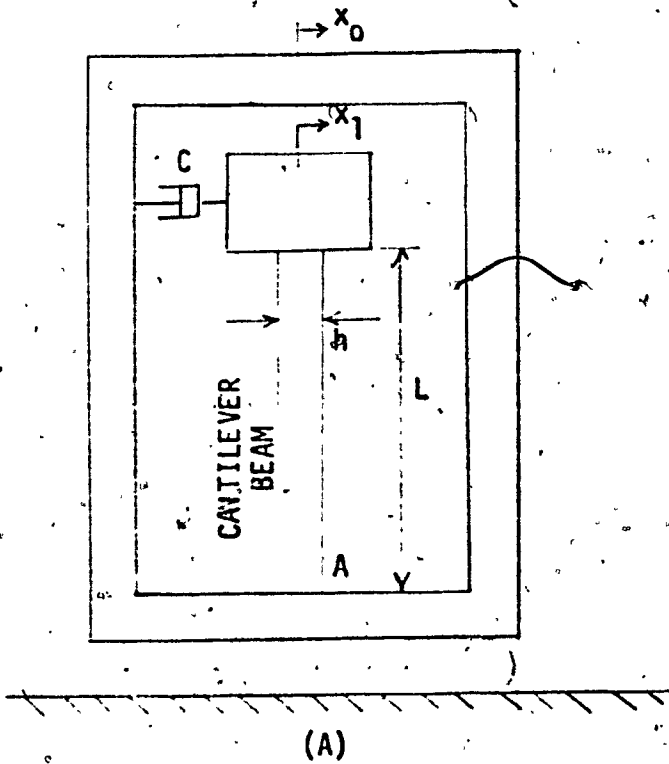

FIG 5.2 (A) and (B) MODEL FOR RANDOM FATIGUE ANALYSIS [8]

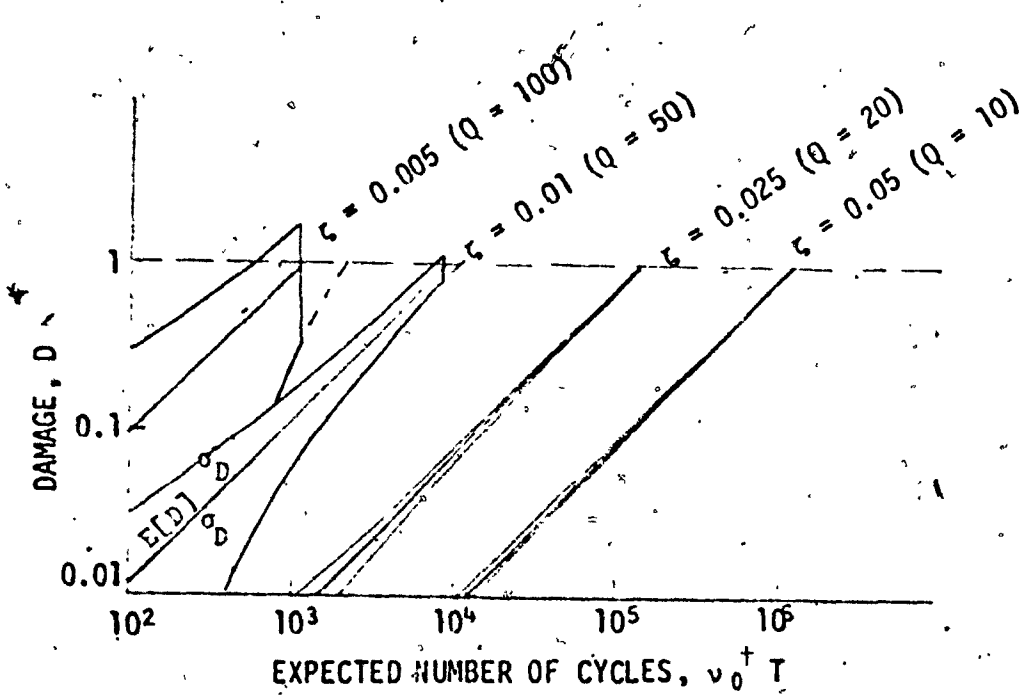

FIG 5.3 PALMGREN-MINER DAMAGE AT ROOT OF CANTILEVER BEAM IN FIG 5.2
DUE TO RANDOM EXCITATION WITH UNIFORM SPECTRAL DENSITY.
THE MEAN DAMAGE EXPECTED IS SHOWN TOGETHER WITH THE PLUS
AND MINUS ONE-SIGMA LIMITS [8]

CHAPTER 6

Conclusions and Recommendations

This review of some of the theories of fatigue damage (and life) prediction, in random load environment, shows a considerable progress in the state of the art. Initially only the Palmgren-Miner theory was available. This theory employs a simple cumulative damage concept. Gradually it was recognised that fatigue damage due to random loading is non-cumulative, since carefully controlled tests failed to confirm the Miners rule. There have been a number of attempts to try to derive analytical models of the fatigue damage process, without the shortcomings of the Palmgren-Miner rule.

The theories of Miles [7] and Crandall [8] are pioneering efforts to establish a method for estimating fatigue damage for use in design. Their method although mathematically tedious is straightforward. All the parameters to be used in the calculations are easily available. Miles theory suffers from the assumption that the damage per cycle is cumulative and the parameters describing the damage are deterministic.

Other workers [27] showed that under carefully controlled experiments, same type of test results repeated over again showed a randomness leading to the conclusion that damage in itself is a random variable. Efforts have been directed towards fitting a known theoretical distribution function [26, 28], normal, extreme value, Weibul etc., for the number of cycles to failure at a given stress level. The failure distribution or the survival function is thus determined.

Some investigations [26] conclude that the change of the material properties of the structure undergoing random cycling (implying non-stationarity of the fibre strength) is a fundamental fatigue phenomenon which must be included in any fatigue damage model. Freudenthal and Heller [33] proposed a modification of the Palmgren-Miner equation for failure prediction, by 'stress interaction' factors which must be determined experimentally. Gatts [34, 35] proposed a theory based on the change in the material endurance limit and the ultimate strength while undergoing random loading. Unfortunately this theory suffers from some un-realistic assumptions.

A number of investigations [38 - 41] have devoted their efforts towards studying the accumulation of fatigue damage under the variable load levels encountered in service. Especially for aircrafts the service loads have been measured [43 + 46] and statistically described by 'load spectra'. These show the relationship between the loads and their relative frequency of occurrence. Fatigue tests on full scale aircrafts have also been conducted [41]. The results of these expensive tests although useful are not general enough for a wide application.

Systematic research is providing ways for rationalizing observed behaviour and for anticipating failure. However so far a reliable procedure for fatigue life prediction is not yet available. Some authors [39] advocate the generation of random load fatigue data in the form of RMS stress vs time (or cycles) to failure curves.

Effects of spectrum shape and width, and other parameters can be indicated for the type of curve as they are developed. This information

would be analogous to what is available for the constant amplitude type of loading. This suggestion seems impractical, since due to the number of variables involved the amount of testing would be enormous.

The use of high strength materials of low fracture toughness has increased the chance of major failures caused by moderate damage or flaws. This has led to an increased interest in Fracture Mechanics [47 - 52] and its combination with fatigue damage theories to predict the reliability of structures under random loading [53]. A minute flaw is assumed to exist in any manufactured part. This flaw then propagates under the applied loading until a critical combination of crack length and applied stress produces failure. Fracture mechanics analysis procedures appear capable of treating only the simple problems of this type, and are not yet adequate for complex structures. However, application of these procedures has developed the 'fail-safe' design philosophy [46]. In this design method a crack is allowed to propagate in a structure until such time as the remainder of the structure retains an acceptable level of airworthiness. Appropriate inspection techniques and schedules are defined to check the crack propagation.

Among the number of available theories for prediction of fatigue lives under random loading only the ones due to Miles and Crandall are easily adaptable to practical problems at the design stage. Other theories require a substantial amount of experimental data, which may not be readily available.

Although there are a number of theories of failure, the literature on the testing under random environment is scanty. The design and development of a suitable random loading fatigue testing machine which can put many of these theories to test is wanting. The equipment design must be simple straight forward yet at the same time sophisticated enough to handle random environment problems. It is recommended that a project should be initiated to design and develop the random load fatigue testing machine somewhat on the lines of the repeat shock loading machine developed by Srinivasan and Rau [43].

REFERENCES

1. Poncelet, "Mechanique Industrielle", pp 317, 1839
2. Rankine W. J., Proc. Inst. of Civil Eng. (London), Vol. 2, pp. 105, 1843
3. Wohler A., Engineering, (London), Vol. 11, 1871
4. Miner M.A., "Cumulative Damage in Fatigue," Jour. App. Mech., Vol. 12, No. 3, Sept. 1945, pp. 159-164
5. Palmgren A., "Die Lebensdauer von Kugellagern", Zeitschrift des Vereines Deutscher Ingenieur, Vol. 68, No. 14, 1924, pp. 339-341
6. Lin Y. K., "Probabilistic Theory of Structural Dynamics", McGraw Hill Book Co., 1967
7. Miles J. W., "On Structural Fatigue Under Random Loading", Jour. Aero. Sci., Vol. 21, 1954, p. 753
8. Crandall S. H., Mark W. D., and Khabbaz G. R., "The Variance in the Palmgren-Miner Damage Due to Random Vibrations", Proc. 4, U. S. National Congress of App. Mech., ASME, Vol. 1, 1962, pp. 119-136
9. Rice S. O., "Mathematical Analysis of Random Noise", Bell Sys. Tech. Jour., Vol 23, 1944, pp. 282-332
10. Lin Y. K., "Random Processes", Applied Mechanics Rev. Vol. 22, No. 9, Sept. 1969
11. Liepmann H. W., "On the Application of the Statistical Concepts to the Buffeting Problem", Jour. Aero. Sci., Vol. 19, No. 12, Dec. 1952, pp. 793-800.
12. Luskin H., and Lapin E., "An Analytical Approach to the Fuel Sloshing and Buffeting Problem of Aircraft", Jour. Aero. Sci. Vol. 19, No. 4, April 1952, pp. 217-228.
13. Lin c. c., "On the Motion of a Pendulum in Turbulent Flow", Quar. App. Math., Vol. 1, 1943, p. 43
14. Lighthill M.J., "On Sound Generated Aerodynamically", Proc. Roy. Soc. London (A), Vol. 211, 1952, pp. 564-587
15. Taylor J., "Measurement of Gust Loads in Aircraft", Jour. Roy. Aero. Soc., Vol. 57, 1953, pp. 78-88

16. Tung C. C.,
Penzien J.,
and Horonjeff R., "The Effect of Runway Unevenness on the Dynamic Response of Supersonic Transports", NASA CR-119, Univ. Cal. Berk., 1964
17. Kirk c.L.,
and Perry P.J., "Analysis of Taxiing Induced Vibrations in Aircraft by the Power Spectral Density Method", Jour. Roy. Aero. Soc., Vol. 75, March 1971, pp. 181-194
18. Sankar T.S., "Random Vibration" Course Lecture Notes, Sir George Williams University.
19. Roberts J.B., "Structural Fatigue under Non Stationary Random Loading", Jour. Mech. Eng. Sci., Vol. 8 No. 4, 1966
20. Fung Y.C., "The Analysis of Random Stresses in Aircraft Structures During Landing as Non Stationary Random Process", Jour. App. Mech., Vol. 22, 1955, pp. 449-457
21. Amin M., "Non Stationary Stochastic Model for Strong Motion Earthquakes", Ph. D. thesis, Univ. Ill., 1966
22. Crandall S.H., Ed. "Random Vibrations", The MIT Press, Cambridge Mass., 1963
23. Shanley F.R., "A theory of Fatigue Based on Unbonding During Reversed Slip" RAND Rep. p-350 Santa Monica, Calif., 1952
24. Brinbaum Z.W.,
and Saunders S.C., "A Probabilistic Interpretation of Miners kule", Symposium on Modern Aspects of Dynamics, Soc. Ind. and Appl. Math., 1967
25. Leybold H.A.,
and Haumann E.C., "A Study of Fatigue Life Under Random Loading", Proc. ASTM, Vol. 63, 1963, p. 717
26. Kozin F., "Statistical Models of Cumulative Damage", NASA Rep. No. 64-17, 1964
27. Gumbel E.J., "Statics of Extremes", Columbia University Press, New York, 1958
28. Murphy R. B., "Reliability", Proc. First Symp. on Engineering Applications of Random Function Theory and Problems, Ed., by Bogdanoff and Kozin F., John Wiley and Sons, N.Y., 1963

29. Parzen E., "On Models for the Probability of Fatigue Failure of a Structure", App. Math. and Stat. Lab., Stanford Univ., Tech. Report No. 45, 1959
30. Smith W.L., "Renewal Theory and its Ramifications", Jour. Roy. Stat. Soc., Vol. 20, No. 2, 1958, p. 243
31. Parzen E., "Stochastic Processes", Holden Day San Francisco, 1962
32. Freudenthal A.M., "Fatigue of Structural Metals Under Random Loading", Symp. on Acous. Fatigue, ASTM Tech. Publ., No. 284, 1960, p.26
33. Freudenthal A.M., and Heller R.A., "On Stress Interaction in Fatigue and a Cumulative Damage Rule", Jour. Aero/Space Sci., Vol. 26, No. 7, July 1959
34. Gatts R.R., "Application of a Cumulative Damage Concept to Fatigue", Jour. Basic Eng., Trans. ASME, Sec. D, Vol. 83, No. 4, Dec. 1961, p. 529
35. Gatts R.R., "Cumulative Fatigue Damage With Random Loading", Jour. Basic Eng., Trans. ASME, Sec. D, Vol. 84, No. 3, Sept. 1962, p. 403
36. Henry D.L., "A Theory of Fatigue Damage Accumulation in Steel", Trans. ASME, Vol. 77, 1955, p. 913
37. Valluri S.R., "A Unified Theory of High Stress Level Fatigue", Aerospace Eng., Oct. 1961
38. Freudenthal A.M., "Random Fatigue Testing", Proc. Am. Soc. Test Mat., Vol. 53, 1953, p. 896
39. Swanson S.R., "Random Load Fatigue Testing - State of the Art Survey", Mat. Res. Stand., Vol. 8, No. 4, April 1968, pp. 10-44
40. Brown G.W., and Ikegami R., "The Fatigue of Aluminum Alloys Subjected to Loading", Exp. Mech., Vol. 10, No. 8, Aug. 1970, pp. 321-327
41. Jacoby G.H., "Comparison of Fatigue Lives under Conventional Program Loading and Digital Random Loading", ASTM STP-462, Jan. 1970
42. Schilve J., "Endurance Under Program-Fatigue Testing", Fullscale Fatigue Testing of Aircraft Structures, Ed. by Plantema F. and Schilve J., Pergamon Press, New York, 1961

43. Srinivasan P.,
and Rau I.S., "Repeated Shock Loading Machine", Engineering,
16 Aug. 1968
44. Lundberg B., "Fatigue Life of Airplane Structures", Jour.
Aero. Sci., Vol. 22, No. 6, June 1955
45. US Dep. Defence "Airplane Strength and Rigidity Requirements",
Spec. MIL-A-8866, 1960, Dept. of Defence,
Washington D.C.
46. US Dep. Defence "Airplane Strength and Rigidity Flight Loads",
Spec. MIL-A-8861, 1960, Dept. of Defence,
Washington D.C.
47. Gassner E.,
and Schutz W., "Fatigue Design Procedures", Pergamon Press,
N.Y., 1969
48. Smith S.H., "Fatigue Crack Growth under Axial Narrow Band
Random Loading", Acoustic Fatigue in Aerospace
Structures, Ed. by Trapp J.W., and Forney P.M.,
Syracuse University Press, 1965
49. Yang J.N.,
and Heer E., "Reliability of Randomly Excited Structures:",
AIAA Journal, Vol. 9, No. 7, July 1971,
pp. 1262-1268
50. Griffith A.A., "The Phenomenon of Rupture and Flow in Solids",
Phil. Trans. Roy. Soc. Lond., Ser. A, Vol. 221,
1920
51. Irwin G.R., "Relation of Stresses Near a Crack to the Crack
Extension Force", IX th Int. Cong. Appl. Mech.,
Univ. Brussels, Vol. 8, 1957
52. Lardner R.W., "Crack Propagation under Random Loading", Jour.
Mech. Phys. Solids, Vol. 14, No. 1, 1966
53. Paris P.,
and Erdogan F., "A Critical Analysis of Crack Propagation Laws",
Jour. Bas. Eng., Vol. 85, 1963, pp. 528-543
54. Yang J.N.,
and Shinozuka M., "On the First Excursion Probability in Station-
ary Narrow Band Random Vibrations", Paper No.
71-APM-19, Applied Mechanics Conference, Univ.
of Penn., June 1971
55. Lyon R.H., "On the Statistics of a Randomly Excited Hard-
Spring Oscillator II", Jour. Acous. Soc. Am.,
Vol. 33, No. 10, 1961, pp. 1395-1403
56. Crandall S.H.,
Chandiramani K.L.,
and Cook R.G., "Some First Passage Problems in Random Vibra-
tions", Jour. Appl. Mech., Vol. 33, No. 3,
Sept. 1966, pp. 532-538

57. Manson S.S.,

"Fatigue: A Complex Subject, Some Simple Approximations"; Exp. Mech., July 1965, pp 193.

APPENDIX A

Flaw Propagation - Fracture Mechanics Approach
to Fatigue Failure Prediction

A.1 Introduction

Since fatigue failures are difficult to anticipate, it is considered that much will be gained by studying the fatigue process itself.

Smith [48] defines the fatigue process as:

- 1) Fatigue crack initiation, where microscopic slip bands develop immediately within the individual grains of the material. These slip bands progress to form minute cracks.
- 2) Major crack propagation.
- 3) Final crack instability.

It has been found, usually in aircraft structures, that fatigue cracks originate at shallow machining marks left on an otherwise generous fillet radius in the corner of an access opening. Since such machining marks can never be completely eliminated despite expensive inspection techniques, it seems difficult to predict a safe life with satisfactory confidence. Faced with this difficulty designers have turned to fracture mechanics to aid in what is commonly referred to as, 'fail-safe' design [47]. The fail-safe design philosophy depends strongly on consideration of residual strength of partially failed structures, and on the rates of crack propagation. These key features of the fatigue process have so far usually been ignored in the conventional fatigue theories. A brief review of some theories of fatigue failure

under random loading which, consider the crack propagation, is presented below. A sketch of the fracture mechanics theory is given in Appendix B.

A.2 Proposed Hypotheses

Shanley [23] was among the first to propose a theoretical explanation of fatigue failure. He assumed that failure is due to growth and propagation of a crack which may be expressed mathematically as:

$$h = Ae^{\beta n} \quad (A.1)$$

where:

 h = crack depth.

A = a constant.

β = a factor depending on the stress amplitude.

n = number of cycles of stress reversals.

The above expression may be related to fatigue life by the following interpretations:

- 1) Let $h = h_0$ the crack depth at which failure occurs.
- 2) Let $n = N$ the number of cycles to failure.
- 3) Let the crack growth parameter be replaced by the following expression.

$$\beta = C \sigma^\alpha \quad (A.2)$$

where:

σ = the nominal stress.

α = the slope of the S-N curve on log log coordinates

C = a constant.

Substituting eqn (A.2) into (A.1)

$$h_0 = A e^{c \sigma^\alpha N} \quad (A.3)$$

Taking the natural logarithm of both sides of eqn (A.3)

$$\sigma^\alpha N = (\log_e h_0 - \log_e A) / C = B \quad (A.4)$$

where B is a constant.

The objective is to find the constant stress amplitude for which failure occurs after $\Sigma \Delta n$. This is similar to the concept of Miles [7].

A hypothetical diagram of crack size versus number of cycles is shown in fig (A.1). For the sake of discussion curves are shown for two stresses σ_1, σ_2 . It is assumed that Δn_1 and Δn_2 are small relative to fatigue life N, and that failure occurs in fatigue as a consequence of stress reversals randomly on σ_1 and σ_2 . The curves of h vrs n may be considered straight lines for short increments of their lengths. Obviously a single crack must have a growth pattern without discontinuities as shown by the curve for σ_r in fig (A.1). Since the rate of crack growth is assumed to be a function of crack depth, the effective rate of growth at any value n will be determined by the weighted averages of the rates for $\sigma_1, \sigma_2 \dots \sigma_n$, at the same crack depth. This may be generalized as follows:

$$\left(\frac{dh}{dn}\right)_r = \frac{\Sigma \Delta n_i \left(\frac{dh}{dn}\right)_i}{\Sigma \Delta n_i} \quad (A.4a)$$

Upon further assumptions and algebra Shanley defines the reduced stress σ_r non-dimensionally with reference to the rms stress $\sqrt{\bar{\sigma}^2}$ of the sequence of varying stress cycles as:

$$\frac{\sigma_r}{\sqrt{\sigma^2}} = \left[\frac{\sum_i \Delta n_i \left(\frac{\sigma_i}{\sqrt{\sigma^2}} \right)^{\lambda \alpha}}{\sum_i \Delta n_i} \right]^{1/\lambda \alpha} \quad (\text{A.5})$$

The parameter λ in the above eqn (A.5) must be evaluated on the basis of experimental data.

Charles Crede [22] extended eqn (A.5) for the case of the narrow band random loading. He obtained the summation of the stress amplitudes in eqn (A.5) by integrating the expression that defines the probability density of the peak values in the narrow band pattern. Upon using the approximation that $\lambda \alpha$ is much larger than unity and the reciprocal $1/\lambda \alpha$ is small, the final result is obtained as:

$$\frac{\sigma_r}{\sqrt{\sigma^2}} = (\sqrt{2\pi}/2)^{1/\lambda \alpha} \sqrt{\frac{\lambda \alpha}{e}} \quad (\text{A.6})$$

Using the concepts of fracture mechanics and the point processes [10], Yang and Heer [49] recently (1971) proposed a theory for the prediction of the reliability of structures under stationary random excitations. Their approach takes into account the interaction of catastrophic failure modes and fatigue failure modes, as well as the statistical variation of the material strength.

Yang and Heer consider the mechanisms of fatigue failure viz (1) flaw initiation (2) flaw propagation and (3) catastrophic failure. The last two mechanisms of the fatigue process are of primary concern in structural design. Yang and Heer state that the flaw initiation stage is the one about which little is known at present and it may be assumed that the material already has flaws that will propagate under repetitive stress applications with sufficient loading. Thus they

define the fatigue failure process as the growth of flaws in a structure until the applied stress at any flawed point exceeds the critical fracture stress associated with the flaw at that critical point and catastrophic failure occurs. They derive a flaw propagation law by considering 'A' to represent the flaw size at the critical point of the structure. From the well known Griffith-Irwin [50, 51] equation:

$$A = Q (K_{IC}/R)^2 \quad (A.7)$$

$$A = Q (K_I/S)^2 \quad (A.8)$$

where:

K_{IC} = the critical stress intensity factor.

R = the critical fracture stress or the resisting stress associated with the flaw size A.

K_I = the stress intensity factor associated with the flaw size A and the applied stress S.

Q = a state parameter.

The flaw propagation law [48-53] takes the form:

$$dA/dn = C K_I^b \quad (A.9)$$

This states that the rate of flaw extension with respect to the number of stress cycles n is proportional to the b^{th} power of the stress intensity factor K_I , where c is a suitable constant. From analyses and measurements of flaw propagations [50-52] the values for b have been found to be between 2 to 4. Substituting eqn (A.9) into (A.7) Yang and Heer obtain:

$$dA/dn = K S^b A^{b/2} \quad (A.10)$$

where $K = C/Q^{b/2}$ is a constant.

Integrating eqn (A.4) successively with respect to each cycle and summing they get:

$$\ln A_n - \ln A_0 = K \sum_{j=1}^n S_j^b \quad (A.11)$$

where S_j is the j^{th} peak of the stress response $S(t)$. The initial resisting stress R_0 and flaw size A_0 are related to the resisting stress R_n and flaw size A_n after n cycles via eqn (A.7) as:

$$R_n = R_0 \exp \left(-\frac{K}{2} \sum_{j=1}^n S_j \right) = R_0 \exp (-Z_n) \quad (A.12)$$

provided the event $\left\{ \bigcap_{j=1}^n (R_{j-1} > S_j) \right\}$ occurs.

In eqn (A.12) R_n is defined as a conditional random variable, upon the condition that the structure has survived n cycles of stress application. It is also seen from eqn (A.12) that R_n after n stress cycles decreases monotonically with respect to the number of stress cycles n .

Since R_0 and S_j ; $j = 1, 2, \dots, n$, are random variables. Yang and Heer consider that the statistical distribution of R_n depends on the statistical distributions of R_0 and the stress peaks S_j ; $j = 1, 2, \dots, n$. Thus the authors argue that the statistical characteristics of the stress peaks instead of the random response process $S(t)$ are of primary interest. The authors then discuss the statistical characteristics of the stress peaks S_j ; $j = 1, 2, \dots, n$, which they derive from the stress response process, $S(t)$, and the extreme point process [6, 54]. The m^{th} local (maximum) peak and the minimum (trough) of $S(t)$ are denoted as S_m and \bar{S}_m . The local maxima form the maximum

point process $\{S_n\}$ and the local minima form the minimum point process $\{\bar{S}_n\}$. The extreme point process $\{\eta(n)\}$ of $S(t)$ is defined as the mixed point process consisting of $\{S_n\}$ and $\{-\bar{S}_n\}$. This being a mixture of two events E_1 and E_2 . Thus, the $2m^{\text{th}}$ and the $(2m+1)^{\text{th}}$ point of $\{\eta(n)\}$ represent respectively S_m and $-\bar{S}_m$ i.e. $\eta(2m+1) = -\bar{S}_m$. This implies that $\eta(n)$ represents peak values if n is even, otherwise it represents the absolute values of the troughs if n is odd. The extreme point process is also stationary.

Yang and Heer consider that the first passage one sided barrier problem of the maximum point process $\{S_n\}$, wherein time is measured in terms of the discrete number of cycles n . Similarly, the first passage two sided barrier problem of $S(t)$, with barriers at $\pm \lambda$ can be approximated by the one sided barrier problem of the extreme point process $\{\eta(n)\}$ with a barrier at λ . In this case, however, time is measured in terms of the number of half cycles [53].

Yang and Heer then proceed to obtain the joint density function $f_{sj, sj+m}(x, y)$ of S_j and S_{j+m} the stress peaks of $S(t)$ a stationary narrow band Gaussian stress response process. They define the distribution function $F_{sn}(X)$ of the maximum point process $\{S_n\}$ as:

$$F_{sn}(x) = 1 - \exp\{-x^2/2\sigma_s^2\} \quad (A.13)$$

in which σ_s is the standard deviation of $S(t)$.

Since $S(t)$ is narrow band the joint density function can be approximated by the function $f_s(x, y; \tau)$ of the envelope function of $S(t)$ spaced at a distance $\tau = mT_0$. The expression for the joint density function of an envelope for symmetric spectra was derived by Rice [9]

as:

$$f_s(x,y;\tau) = \frac{xy}{\sigma_s^4 [1-K_0^2(\tau)]} I_0 \left[\frac{xy K_0(\tau)}{\sigma_s^2 [1-K_0^2(\tau)]} \right] \times \exp \left\{ \frac{-(x^2 + y^2)}{2 \sigma_s^2 [1-K_0^2(\tau)]} \right\} \quad (A.14)$$

Yang and Heer use the above equation (A.14) except that since narrow band structural response spectra are not symmetrical, they consider a suitable substitution in the equation for ω_0 . A single degree of freedom system excited by white noise has three possible solutions for ω_0 viz.

- 1) ω_n = the system natural frequency.
- 2) $\omega_d = \omega_n (1 - \zeta^2)^{\frac{1}{2}}$, the damped natural frequency.
- 3) $\omega_c = \frac{\int_0^{\infty} \omega \phi(\omega) d\omega}{\int_0^{\infty} \phi(\omega) d\omega}$, the centroid frequency.

after a critical evaluation the authors found that a particular choice for ω_0 is not critical for $f_s(x,y; mT_0)$. As a result they choose the natural frequency ω_n for ω_0 .

The structural probability for surviving n stress cycles, called reliability $L(n)$ is given as:

$$L(n) = \prod_{n=0}^{n-1} [1 - h(n)] \quad (A.15)$$

or $L(n) \simeq \exp \left\{ - \sum_{n=0}^{n-1} h(n) \right\} \dots$ for $h(n) \ll 1$

where $h(n)$ is the hazard function, defined in 3.3.1, given by the authors as:

$$h(n) = P [R_n \leq S_{n+1} \mid \bigcap_{j=1}^n (R_{j-1} > S_j)] \quad (A.16)$$

Eqn (A.16) is for $\{S_n\}$. A similar equation can be derived for $\{r_j(n)\}$. The solution of eqn (A.16) is obviously quite troublesome. Yang and Heer present two approximate solutions. One using the Poisson approximation and second the clump size approximation.

In using the Poisson approximation the assumption is made that the statistical distribution of the initial resisting stress R_0 , determined experimentally, is log normally distributed. Further reasoning gives that the random variable R_n is also normally distributed whose mean value μ_n and the variance σ_n^2 are given by

$$\begin{aligned} \mu_n &= \mu_0 + \mu_2 \\ \sigma_n^2 &= \sigma_0^2 + \sigma_2^2 \end{aligned} \quad (A.17)$$

where μ_0 and σ_0^2 are the mean value and the variance of R_0 , and μ_2 and σ_2^2 are the mean value and the variance of Z_n .

The expression for σ_2^2 which Yang and Heer derived was fairly complex and they preferred to use the simplified expression obtained by Crandall, eqn (3.18), when c is small and b is odd.

The basic assumption of the Poisson distribution for $\{S_n\}$ gives that S_{n+1} is independent of S_j ; $j = 1, 2, \dots, n$, and the event $\{R_n < S_{n+1}\}$ is independent of the past event. Yang and Heer give the Poisson

failure rate $h_p(n)$ as follows:

$$h_p(n) = \int_0^{\infty} [x \sigma_n (2\pi)^{\frac{1}{2}}]^{-1} \exp \{- [x^2/2 \sigma_s^2] - [(\ln x - \mu_n)^2 / 2 \sigma_n^2]\} dx \quad (A.18)$$

Yang and Heer use Lyons [55] concept of clumps, that the level crossings of $S(t)$ are not independent but occur in clumps of dependent crossings. The Poisson approximation implied that one clump of peaks above the threshold level consist of only one peak. Hence assuming clumps to occur independently the average failure rate $h(n)$ is obtained using eqn (A.18) as:

$$\bar{h}(n) = \int_0^{\infty} \{ x \sigma_n (2\pi)^{\frac{1}{2}} E[M|x] \}^{-1} \exp \{- [x^2/2 \sigma_s^2] - [(\ln x - \mu_n)^2 / 2 \sigma_n^2]\} dx \quad (A.19)$$

where $E[M|x]$ is the average clump size given that the barrier level is equal to x .

The exact estimation of the average clump size is difficult. Using some numerical simulation results [56], the authors obtain for a single degree of freedom system:

$$E[M|x] = n \exp(-x^2 / 2 \sigma_s^2) \quad (A.20)$$

where:

n = the mean number of cycles to failure.

x = the barrier level.

Thus after determining the average failure rate or the hazard function

from either eqn (A.18) or (A.19) the structural reliability is obtained from eqn (A.15). Yang and Heer conclude from their extensive study that the average failure rate and hence the structural reliability are characterized by the following properties.

- 1) The material properties associated with the flaw propagation.
- 2) The initial strength, or flaw size dispersion.
- 3) The normalized initial barrier level, measure of the central safety factor, relating the applied load characteristics to the structural design.

Yang and Heer also emphasise the following features of their theory.

- 1) Accounting of the interaction of the fatigue failure modes, the catastrophic failure modes, as well as the statistical variation of the material properties.
- 2) The effect of the loading history is considered, which is not accounted for in the classical Palmgren-Miner hypothesis.

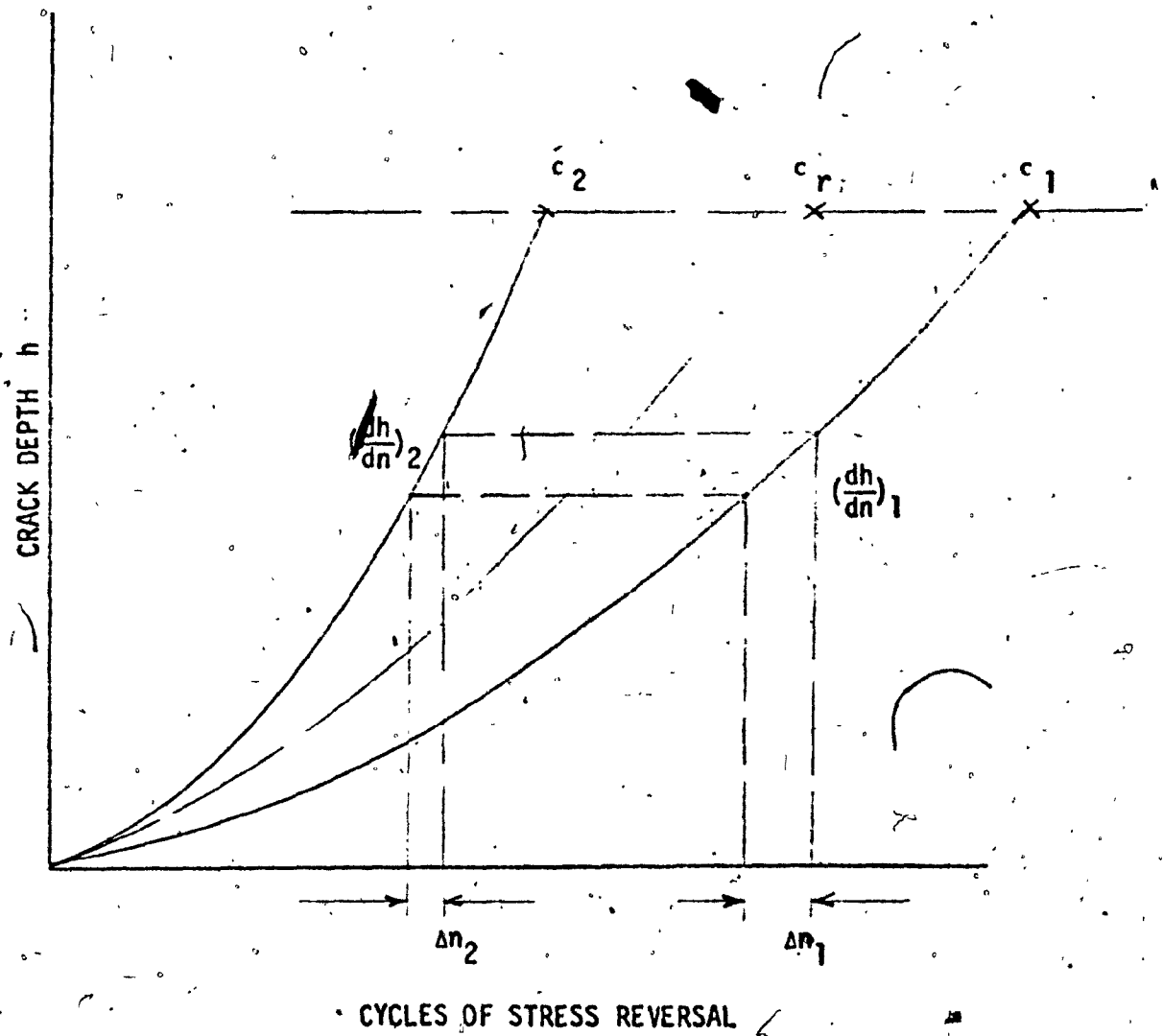

FIG A.1 CRACK DEPTH VRS STRESS CYCLES [23]

APPENDIX B

A Brief Review of the Fracture Mechanics Theory

The mechanics of crack propagation was developed by Griffith and Irwin [50, 51]. Griffiths based his original theory on an energy balance concept. He treated the stability of cracks or imperfections in an ideally brittle solid. Using the theorem of minimum potential energy, Griffith showed that at the onset of rapid fracturing, or crack instability, the strain energy release rate is a minimum and proportional to the surface tension of the material. Griffiths experiments on cracked glass spherical bulbs and circular tubes demonstrated that the strain energy release rate at fracture for the glass specimen configuration was a material constant. In addition, the experiments demonstrated that there was no effect due to the tensile stress applied parallel to the crack.

The brittle fracture characteristics of the ductile materials was described by Irwin as an extension to the Griffiths theory. Griffith did not consider energy dissipation due to the local plastic deformation, which Irwin took into account by including another energy term.

Irwin has shown that the stresses acting on an element of material near a crack tip are given by:

$$\begin{aligned} \sigma_x &= \frac{K}{\sqrt{2r}} \cos \frac{\theta}{2} \left[1 - \sin \frac{\theta}{2} \cdot \sin \frac{3\theta}{2} \right] \\ \sigma_y &= \frac{K}{\sqrt{2r}} \cos \frac{\theta}{2} \left[1 + \sin \frac{\theta}{2} \cdot \sin \frac{3\theta}{2} \right] \\ \tau_{xy} &= \frac{K}{\sqrt{2r}} \sin \frac{\theta}{2} \cdot \cos \frac{\theta}{2} \cdot \cos \frac{3\theta}{2} \end{aligned} \quad (8.1)$$

where the relevant symbols are shown in fig (B.1) and K is an stress intensity factor which is a function of applied stress level and crack length.

In considering only the opening mode of crack extension, the stress intensity factors which describe the fracture mode are the plain strain, K_{IC} , and plain stress, K_C . Other stress intensity factors describing other modes of crack extension have been developed by other authors.

At the onset of rapid fracturing or crack instability, the strain energy release rate, G , is a function of the critical stress intensity factor i.e.

$$G_C = K_C^2 / E \tag{B.2}$$

$$G_{IC} = (1 - \nu^2) \pi K_{IC}^2 / E$$

The material constants G_C , G_{IC} or K_C and K_{IC} are evaluated experimentally by conducting tension tests on cracked specimens.

The crack propagation due to sinusoidal fatigue loading is given by Paris et al [53]. Realising that the stress intensity parameter, K , in eqn (B.1) is a measure of the local intensity of stress at the crack tip, the authors hypothesized that the rate of crack extension, caused by sinusoidal fatigue loading, is governed by the magnitude of the crack tip stress intensities i.e. the range and mean values. Experimental results substantiating their theory have been presented by the investigators. A positive correlation was found, from mater-

ial data plots of stress intensity factor vrs crack growth rate.

Consider fig (B.2a) where the fatigue crack growth behaviour of a material from an initial crack length, $2a_0$, has been determined experimentally for two different stress ranges, σ_1 and σ_2 , and identical ratios of mean stress and stress range, also $\sigma_2 > \sigma_1$. The critical crack lengths and cycles to failure at σ_1 and σ_2 are governed by the critical stress intensity factor of the material. The general functional relationship of the stress intensity factor, K , for cracked specimen configuration is as follows:

$$K = c \cdot F(2a) \quad (B.3)$$

where c is a stress parameter.

Fig (B.2b) shows that in reducing the crack length vrs cycles plot to a stress intensity vrs crack growth rate plot, the data generated at stress levels σ_1 and σ_2 coincide for a given material. This means that for the same K level or local crack tip stress field conditions, the crack growth rates are identical. As the crack stress intensity increases the crack growth rate increases to the point of onset of rapid fracture, which is governed by the critical stress intensity of the material. Test results indicate the validity of the stress intensity factor concept. Within a small amount of scatter, the same crack growth rate occurs at a given stress intensity range level, K_h , and ratio n defined as:

$$n = K_{MEAN} / K_h \quad (B.4)$$

Once the basic sinusoidal stress intensity vrs. crack growth rate behaviour of a structural material is established by simple specimen tests, the behaviour of an assumed initial crack in a complex structure can be predicted by integrating the basic data. That is an S-n curve for the structural life from an initially assumed crack length can be determined, provided an analysis of the stress field remote from the crack tip is established and reduced to the appropriate K factors.

Fatigue crack growth rate under random loading has been studied by Smith [48]. His approach is based on the model proposed by Paris, which describes eqn (B.3) in terms of the stress intensity factor - power spectral density function

K(f) as :

$$K(f) = S(f) \cdot F(2a) \quad (B.5)$$

where S(f) is the stress power spectral density function and 2a the crack length.

Thus a measure of the crack tip stress field fluctuations due to random loading is given by the power spectrum plot of the stress intensity factor. Smith postulates that according to the stress intensity factor concept, it would be expected that the same random loading fatigue crack growth rate will occur in a material, if the mean stress intensity level and stress intensity power spectrum are identical.



FIG B.1 - STRESSES ACTING ON ELEMENT OF MATERIAL
NEAR CRACK TIP

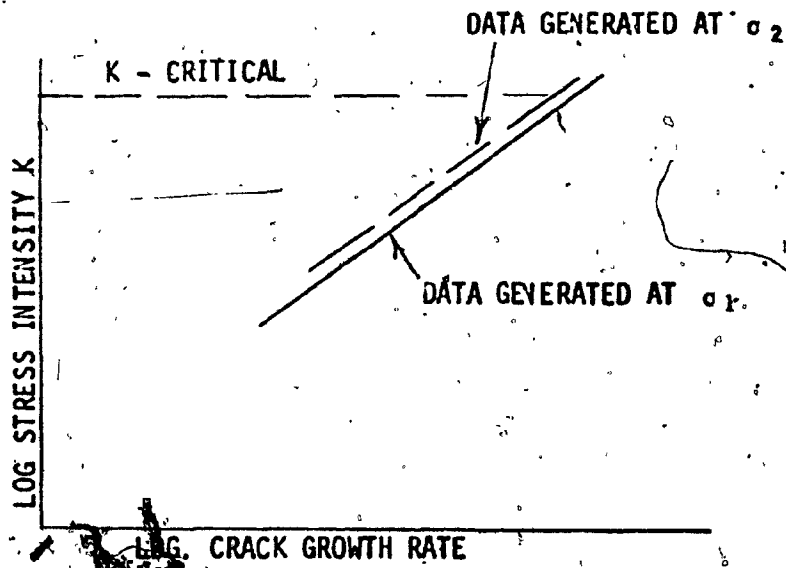
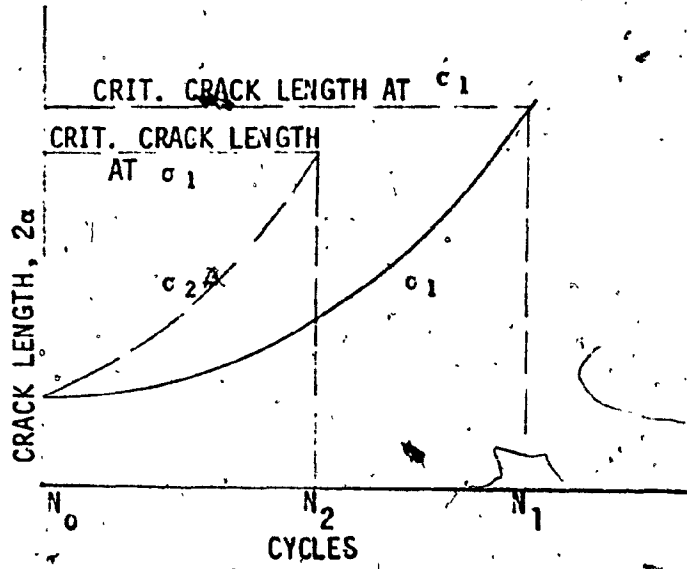

FIG B:2 FATIGUE CRACK GROWTH RATE CORRELATION DATA

END

11 • 02 • 75

FIN