

Performance Evaluation of Signage System in Subway Stations

Qingjie Zeng

A Thesis in

The Department

of

Building, Civil and Environmental Engineering

Presented in Partial Fulfillment of the Requirements

for the Degree of Master of Applied Science (Civil Engineering) at

Concordia University

Montreal, Quebec, Canada

April 2011

© Qingjie Zeng, 2011

CONCORDIA UNIVERSITY
School of Graduate Studies

This is to certify that the thesis prepared

By: Qingjie Zeng

Entitled: Performance Evaluation of Signage System in Subway Stations

and submitted in partial fulfillment of the requirements for the degree of

Master of Applied Science (Civil Engineering)

complies with the regulations of the University and meets the accepted standards with respect to originality and quality.

Signed by the final examining committee:

Michelle Nokken

Chair

Luis Amador

Examiner

Amin Hammad

Examiner

Ciprian Alecsandru

Supervisor

Approved by _____

Chair of Department or Graduate Program Director

Dean of Faculty

Date _____

ABSTRACT

Performance Evaluation of Signage System in Subway Stations

Qingjie Zeng

An information integrated, recognition accessible and format standardized signage system is not only a basic feature of a subway station, but also a factor that contributes to the smooth and well-organized operation of the subway service. To figure out the deficiency and limitation of existing signs in one subway station, and to further recover and improve the signage function, a comprehensive performance assessment of the signage system is necessary and compulsory, if not periodically, as least when major system modifications/enhancements are executed. In this study, a methodology is proposed to evaluate the signage performance from three aspects: information integration, visibility optimization and legibility standardization.

Information integration requires a complete signage system in the station offering demanded and mandatory information to the public. It is examined via a comparison between the existing signs and a standardized signage system, which is defined in three stages: station element and passenger flow identification, signage definition and classification, and signage implementation. Visibility optimization means the signs should be set and installed in a proper way regarding to the color, panel size, lighting, orientation and height, to maximize their ability of drawing and facilitating passenger's attention and recognition. The visibility of one sign is evaluated as one of the three levels: optimized visibility, limited visibility and impaired visibility. Legibility standardization introduces guidelines on format displaying of signs with respect to typeface, color

application and information presentation, to achieve for passenger's easy acceptance and understanding of signage information.

Based on the methodology, an implementation flowchart is developed for generic signage evaluation in one subways station. A case study (Berri-UQAM Metro station) in Montreal city is tested as a step-by-step application of this methodology in a real-world system. The absent signs and signs that need improvement are identified in detail and the evaluation result is summarized, as basis for further ameliorative measures.

ACKNOWLEDGEMENTS

Here I would like to pay my sincere and deepest appreciation to you, who supported, encouraged, instructed, and supervised me on my paper and thesis, on my study and research, and on my whole life.

TABLE OF CONTENTS

LIST OF FIGURES	ix
LIST OF TABLES	xi
CHAPTER 1	1
INTRODUCTION	1
1.1 Background and Problem Statement.....	1
1.2 Objectives	2
1.3 Organization of Thesis.....	3
CHAPTER 2	4
LITERATURE REVIEW	4
CHAPTER 3	10
METHODOLOGY	10
3.1 Information Integration.....	10
3.1.1 Stage 1: Station Element and Passenger Flow Identification	11
3.1.2 Stage 2: Signage Definition and Classification	13
3.1.3 Stage 3: Signage Implementation	19
3.1.4 Comparison between Existing and Standardized Signage System	23
3.2 Visibility Optimization	25
3.3 Legibility Standardization.....	32
3.3.1 Typeface.....	33

3.3.2 Color Application.....	35
3.3.3 Information Presentation.....	38
3.4 Implementation Flow of Signage Evaluation	40
CHAPTER 4	42
CASE STUDY: BERRI-UQAM STATION	42
4.1 Station Investigation and Passenger Flow Identification.....	43
4.2 Signage Classification and Coding.....	46
4.2.1 Guidance Signs Generation.....	47
4.2.2 Normative Signs Generation.....	51
4.2.3 Indication Signs Generation.....	52
4.3 Signage Assigning on Floor Plan.....	54
4.3.1 Guidance Signs Implementation	54
4.3.2 Normative Signs Implementation	59
4.3.3 Indication Signs Implementation	59
4.4 Signage Performance Evaluation.....	62
4.4.1 Signage Checking	62
4.4.2 Signage Evaluation (Grading) Results.....	62
4.4.3 Recommendations Pertaining to Signs Legibility.....	63
CHAPTER 5	68
CONCLUSIONS AND FURTHER WORK	68

5.1 Summary	68
5.2 Concluding Remarks	70
5.3 Further Work	72
REFEFENCES	73
APPENDIX I	77
APPENDIX II	91

LIST OF FIGURES

Figure 3.1 General Passenger Flows between Station Elements	12
Figure 3.2 Utility Zones at Three Levels of Detail.....	14
Figure 3.3 Utility Zones in One Traveling Scope.....	15
Figure 3.4 Examples of Guidance Signs (Montreal Metro ©).....	17
Figure 3.5 Examples of Normative Signs (Montreal Metro ©).....	18
Figure 3.6 Examples of Indication Signs (Montreal Metro ©).....	18
Figure 3.7 Schematic Example of Implementation of Guidance Signs	21
Figure 3.8 Multiple Implementation of Indication Signs.....	23
Figure 3.9 Color Contrast between Signage and Background.....	26
Figure 3.10 Signage Size Affects Visual Sense.....	27
Figure 3.11 Signage Lighting (Montreal Metro ©)	28
Figure 3.12 Orientation of Sign Panel (Montreal Metro ©)	29
Figure 3.13 Required Ratio for Legible Typeface (31)	34
Figure 3.14 Height Ratio between Upper-case and Lower-case Letter (9)	34
Figure 3.15 Minimum Heights of Upper-case Letter at Different Viewing Distances (29)	35
Figure 3.16 Line Spacing (29)	36
Figure 3.17 Comparison between Different Color Contrasts	36
Figure 3.18 Application of Color Coding in Practice (Montreal Metro ©).....	37
Figure 3.19 Hierarchy in Guidance Information Presentation.....	39
Figure 3.20 Standardized Signage Symbols in Beijing Subway (Beijing Subway ©)	40
Figure 3.21 Implementation Flowchart of Signage Evaluation	41

Figure 4.1 Neighborhood Map of Berri-UQAM (Montreal Metro ©)	43
Figure 4.2 Structural Sketch of Berri-UQAM Station	45
Figure 4.3 Floor Plan at Hall Level	46
Figure 4.4 Layout of Recommended Guidance Signs Implementation for Access Scope	56
Figure 4.5 Layout of Recommended Guidance Signs Implementation for Egress Scope	58
Figure 4.6 Example of Floor Plan at Hall Level with Marked Signage Codes	61
Figure 4.7 Existing Guidance Signs Installed on Light-box (Montreal Metro ©).....	64
Figure 4.8 Examples of Bad Hierarchy (Montreal Metro ©)	65
Figure 4.9 Examples of Suggested Signage Layout	66
Figure 4.10 Other Defects on Legibility (Montreal Metro ©).....	67

LIST OF TABLES

Table 3.1 Utility Zones at Microscopic Level in One Station	16
Table 3.2 Relationship between Height and Viewing Distance of Signage (18).....	30
Table 3.3 Hypothetical Cases of Visibility Optimization Evaluation.....	32
Table 4.1 Utility Zone Determination.....	48
Table 4.2 Classification and Coding of Guidance Signs	51
Table 4.3 Classification and Coding of Normative and Indication Signs.....	53
Table 4.4 Implementation of Normative and Indication Signs.....	60

CHAPTER 1

INTRODUCTION

1.1 Background and Problem Statement

The first subway system in the world (Metropolitan Railway) was built in London in the nineteenth century. Ever since, subway systems have been providing fast and efficient service for the travelers and have accounted for a significant percent of all the public transportation services. Over time, the original facilities and subsystems of a subway network experience different degrees of wear and tear, one of which is the signage system in the station.

The subway signage system is a graphics- and characters-based visual information system that transmits demanded and mandatory traveling information to passengers during their subway trip, ensuring a safe and smooth subway operation. However, in some existing subway stations, limited maintenance results in absence and damage of signs at various locations within the subway system, so that demanded information cannot be communicated to the passengers, which may lead to their hesitancy and confusion, especially for the ones who are not familiar with the system (tourists, visitors, occasional users, etc.). On the other hand, the information communicated by the initial signage system may become inconsistent after the construction of line extensions, addition of facilities in station or improvements of neighboring infrastructures (e.g. other transit stations or points of interest). Consequently, travelers cannot fully benefit from an information friendly transit system if original signs are not improved and new signs are not added when necessary. A well-designed and smooth-operated signage system in a

subway station is not only intended for guiding and informing travelers, but it is also necessary for passenger's comfort, providing a user-friendly environment for travelers, and promoting new ridership. Therefore, a systematic examination and assessment of the signage system in existing subway stations is imperative under the current situation (i.e., signage absence and poor-performance) in the cities with large underground transit systems.

1.2 Objectives

The main objective of this study is to design and establish a framework for evaluating the performance of signage systems serving subway stations. The main purpose of performance evaluation is to ensure that all signs provide guidance and command attention to passengers in the most effective way. Mainly, the proposed methodology is focused on identifying and ameliorating the deficiencies of the signage system in terms of *information integration*, *visibility optimization* and *legibility standardization*.

The above-mentioned three aspects of deficiency are considered as the major evaluation principles in the framework for a comprehensive performance evaluation of a signage system. First, it is important that the information disseminated through the signs is integrated and useful to travelers, which means appropriate signs together with demanded information must be presented at each required location. Second, all the serving signs must achieve an optimal visibility to facilitate traveler's observation and identification of these signs, hence their installation and setting should completely consider the spatial relationship with the surrounding architectural elements and environment (e.g. background color, height, lighting etc.). Third, the information content

(graphics and characters) of the signage system have to be consistently standardized in format displaying, regarding the typeface, color, and content layout, for the purpose of legibility and easy understanding. After performance deficiency is identified and evaluated, measures are raised to improve the existing signage system.

The remainder of this study is organized as follows. First, a review of previous related studies is presented. Next, to evaluate a generic subway station a performance evaluation execution flow chart is proposed. One subway station, Berri-UQAM, from the Montreal Metro system is selected as a case study to apply and validate the proposed methodology. Additional work will be discussed to improve this framework in configurable integrity and practical implementation.

1.3 Organization of Thesis

This thesis is organized in five chapters. The first chapter provides a brief introduction and states the objective and scope of this study. Chapter 2 presents a literature review of the previous studies relevant to this research work. Chapter 3 gives a detailed description of the methodology used in this study. Chapter 4 applies this methodology to one real-world case study. Chapter 5 includes the conclusions drawn from this study and discusses potential research extensions.

CHAPTER 2

LITERATURE REVIEW

With the *Isotype* (i.e. a representation of quantitative information via easily interpretable icons in a symbolic manner) created by Otto Neurath (1) as a new kind of artificial language, the signage systems began their information dissemination function as early as 1930s. Nearly fifty years later, Mclendon and Blackistone (2) defined signage as the “graphic communications in the built world”, which is an act of conveying information from one entity (external environment) to another (people) in a visual mode. The authors developed and generalized design guidelines for symbols and symbol-signs. Ever since, a variety of signage and wayfinding systems have been developed and implemented for different types of facilities such as airport concourses, museums, schools, public spaces. Recently, a more detailed signage system design was developed by Uebele (3). The author created a step-by-step guide that can be used as a signage planning tool. This guide promotes design rules regarding fonts, typographical system and color coding. Meanwhile, some signage systems accommodating relevant daily activities in various concourses, including airport, libraries, exhibitions and businesses, were presented as practical application examples by the author.

Several studies investigated the consistency, classification and efficiency of different signage systems. For example, Garvey (4) evaluated the visibility of an alternative signage typeface (Futura) through an experiment demonstrated in the Miami Beach area. In addition to the large-scale guiding signs on urban roads (4), some researchers focused more on application of wayfinding in one area with specific functions:

signs were classified and placed at circulation paths of one region as a complete system (sign programming), providing necessary clues and environmental information that help people orient themselves and intuitively find their way (5). To make a successful wayfinding system, ten qualifications (simple and concise, visible and recognizable, etc.) were raised that allowed viewers to find their destinations easily and quickly (6).

When wayfinding was applied in architecture, the spatial variability or similarity and environmental complexity could contribute to the user's mental reaction, further even provoked fear when they felt lost in a hermetic building (7). In this situation, not only the signs but also the interior spatial configuration and architectural features, which are key factors, could affect wayfinding design for all the designers (8). Human factors under an indoor environment should be roundly considered by the wayfinding designers, and it is also advisable to provide a comprehensive definition of all the user groups of signage system before the design process (9). Therefore, a universal design is an inclusive design process aimed at enabling all kinds of the people to experience the full benefits of the products and environments around us regardless of the ages, sizes or abilities (10). Based on the idea of universal design, the concept of access for everyone, which means accommodating the needs of all people to the maximum extent possible, was created to identify structural features of buildings and sites that need to be analyzed for accessibility (11). In some particular fields, research and work was made with respect to helping the disabilities with mental or physical difficulties: a report (12) proposed by UK government tried to help people with learning difficulties to identify signs and understand signage information and find their way to the destination; Sánchez and Sáenz (13) evaluated the impact of using the software program AudioMetro, a tool that guides visually impaired

people around the metro system in Santiago; Kong (14) analyzed the special needs of disabled people, and presented some corresponding principles of barrier-free design in subway station. In United States, ADA (Americans with Disabilities Act) standards for accessible design (15) were applied to the places of public accommodation and commercial facilities.

In developing the signage system of a transit network it is important to incorporate the needs of all the travelers (i.e. travelers with limited mobility should benefit equally well as regular travelers from the information provided). Consequently, a signage system must satisfy the demands of travelers with special need and also incorporate architectural integration and the art design component (typeface, size, color). It is equally important that the special category of signs related to traveler's safety within the transit system are properly designed and appropriately located. In order for this category of signs to be effective, their design has to conform to standardized regional and international guidelines. Their location and appearance requires seamless integration with the wayfinding system.

Several studies have been conducted in past years which investigated different signage systems and developed signage planning tools. Zhang et al. (16) proposed a method to design and organize guidance signs in transit centers. The authors considered passenger flow as an important element in determining the distribution of signs. Duszek (17) analyzed the passengers' mental process in the project related to the Warsaw subway signage system. The result revealed vital guiding and orientation information required at different locations and approaches based on predominantly considered users' points of view in the procedure.

Chen (18) investigated the subway signage system in Taipei. Based on local surveys the author provided a range of visual communication criteria which were adopted from previous professional studies. Some recommendations were given to improve the graphic and sign design process to ameliorate passenger navigation within the subway station. Apart from visual design which was generally applied in the subway station, aural and tactual design (e.g. sound or smell) was suggested by Dai (19) as an alternative approach as the design sent unique identification of specific stations. As in the consideration of safety design, Xu et al. (20) proposed optimization suggestions for a safety and disaster-prevention signing system, after the authors investigated some subway systems in several countries and made a comparison between them.

Despite the numerous studies done to standardize the signage system, there is still some deficiency regarding to signage evaluation in the current signage research work for subway stations. This deficiency drives researchers to further look into the qualitative and quantitative aspects of an appropriate signage system. Kong et al. (21) used the analytic hierarchy process to determine weighting factors for indices of the signage system. A comprehensive evaluation system was established by the authors to assess the service efficiency of the system based on the fuzzy mathematics theory. To evaluate the spatial arrangement of the guiding signs, Isovist Superposition Analysis (ISA) was used to analyze the effects of the visual field via the isovist superposition of single-line pedestrian and the weight summation of multi-line visual effects (22). After analyzing the functional locations, passenger flows and the requirement of passenger information, an optimal method based on genetic algorithm (GA) was proposed for the selection of

decision making point. In addition a model using fuzzy evaluation was established to assess the layout planning of guiding signs (23).

In terms of the design and planning of signage system, several specific elements such as regulations or basic requirements regarding color (24, 25), typographic (26) and hierarchy (27) should not be ignored when performing a comprehensive evaluation for the purpose of harmony and a friendly environment in the facilities (28).

Two handbooks presenting the signage planning program in London (29) and Beijing (30) are considered as examples, respectively. The London manual represents the culmination of extensive research, design and development, and consists of three parts: (a) basic elements applied in the signs and their layout on panels; (b) specific guidance regarding the ticket hall signing, platform finding and signing, and exit signing (including emergency exits) which are based on a general customer journey; (c) the indispensable assistant elements (safety and supplementary signs), also with construction and installation guidelines for signs. The Beijing subway signage system identifies all signs and markings that are required in the subway system and prescribes appropriate instructions for sign installation. Detailed examples of signage distribution in the station are illustrated as a standard format, based on the service functions of different signs.

Previous studies are more focused on the signage designing and planning, and how to establish a new signage system, while there are few studies done on the signage performance evaluation. Recently, Zeng et al. (32, 33) proposed and tested a new methodology to assess the signage performance. This study investigates particularly the signage system in one subway station (i.e. Berri-UQAM station in Montreal city) in a

comprehensive fashion targeting all aspects of the signage performance. The study presented in this thesis ameliorates this lack of knowledge in signage research work.

CHAPTER 3

METHODOLOGY

This study proposes a comprehensive evaluation of signage system in a subway station from three main aspects: information integration, visibility optimization and legibility standardization. First and at least, as a minimum requirement of signage system, there should be signs available and the provided information should fulfill the information demand from the traveling public. Second, the signs should be set in a proper way to maximize their visibility, facilitating passengers' recognition of signs. Third, a standardized display of signage information would provide a friendly environment and, in a further step, achieving the most efficient signage performance. Each of these three aspects can be seen as one independent part of performance evaluation and can be applied individually. The implementation steps of this methodology are presented in this section.

3.1 Information Integration

A good signage system firstly should be information complete, which means travelers could refer to the communication transferred from the public server as they need and fulfill their basic information demands. To classify the performance of existing signage system in a subway station as good or not good mainly depends on whether the signage information is complete or not. To identify the absence of signs and information, and evaluate the integration of signage system, a comparison has to be performed between the existing signs in one station, contrast to a proposed standardized signage system for the same studied station. This standardized signage system focuses on the

representation of an integrated information system that satisfies general demands from the public (i.e. the more comprehensive the signage is, the more coherence in provided services can be observed). To define this standardized signage system systematically and consistently, three design stages are performed: (1) station element and passenger flow identification; (2) signage definition and classification; (3) signage implementation.

3.1.1 Stage 1: Station Element and Passenger Flow Identification

The structure of one subway station depends on the station type and its surrounding environment (e.g. terminal or transfer station, connecting to other underground interests), so it is indispensable to understand the station structure and identify the station elements. Basically, the station elements include subway entrance/exit, hall, platform and connecting (path, tunnel, stair or elevator) between them.

The *entrance/exit* is identified as a joint part between the interior and exterior of one station. The interior leads to subway service, while the exterior could connect to the street, bus stop or building in the ground-level, or connect to mall or park in the underground city. And the emergency exit distinct from regular exit should not be ignored if possible, since it is a vital structural part of station under special situations. The *hall* could be seen as a mezzanine with ticket barrier between entrance/exit and platform, where the agency provides subway service (information service, custom service and ticket service) and passengers start their subway trip. The *platform* is the location for passengers boarding and alighting. Besides, path, tunnel, stairs and/or elevator provide connection between these elements, indicating physical routes leading the passenger flows. In this step all the identified elements and their connections should be clear and

definite to fully illustrate the station structure (usually a floor plan would be used), and further determine the passenger flows in the station.

In this study, the property of passenger flow in one station is characterized by one of the following three traveling scopes: *access scope*, *egress scope* and *transfer scope*. An access scope is defined for passengers that start from their origin outside of the station until they board on the train. An egress scope is defined for passengers that get off the train until they reach their destinations outside of the station. And, a transfer scope is defined for passengers that transfer from one platform to another within the same station. The passenger flows under different traveling scopes could weave, merge and overlap in one station, i.e., there could be different information demands from scope-differential passenger flows in the same position on the route. Hence, it is important and mandatory to provide the information and set the corresponding signs along the passenger flows on each traveling scope, respectively, ensuring a consistent and systematic design of the signage information system.

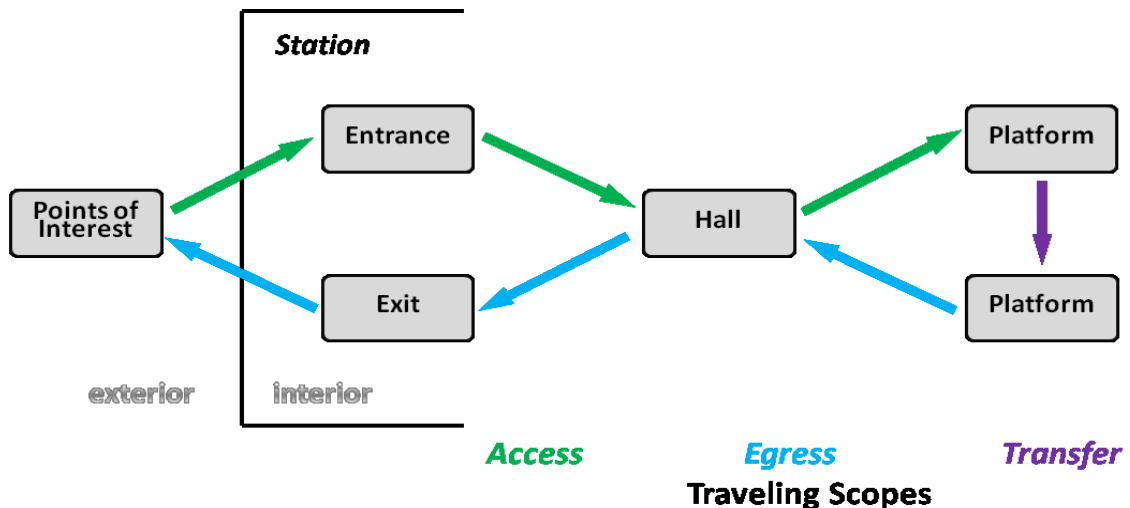

Figure 3.1 General Passenger Flows between Station Elements

In this stage, an explicit blue print of the studied station with specified elements and scope-identified passenger flows is created. It provides an objective environment that the signage information could rely on and consist in, and ensures the following stages are focused on the practical condition of the specific station and operation agency.

3.1.2 Stage 2: Signage Definition and Classification

Signage types could be defined and classified in many ways according to different principles and standards. In this study, for a purpose of generating an information-integrated system in one station, signs are classified into three categories: *Guidance Signs*, *Normative Signs* and *Indication Signs*. This signage classification is based on the information content of signs, with respect to the first aspect of performance evaluation as defined in the framework - a complete information system, satisfying passengers' demands and serving for communication function offered from transportation agency. The remainder of this stage defines each of the three types of signs.

Guidance Signs

This category of signs includes those signs that have the function of wayfinding with a focus on *access*, *egress* and *transfer* scopes. Under these three traveling scopes, it is difficult to provide the guidance information avoiding absence and redundancy, especially in some transfer stations with interlaced passenger flows between multiple entrances/exits and platforms. In this section, a new concept of *utility zone* is created to facilitate the determination and implementation of guidance signs in the station.

A utility zone defines an area with a particular traveling function during a complete trip made by travelers (e.g. boarding area at the platform level). There are two

major features that characterize a utility zone from the signage system perspective: the level of detail and the traveling scope.

The level of detail of a utility zone identifies the magnitude and the nature of traveler flows with respect to the subway station or the transportation facility in general. Consequently, one utility zone can be characterized by one of the three levels of detail: macroscopic, mesoscopic and microscopic, respectively (Figure 3.2). At the macroscopic level, the utility zones are defined in relation to the urban system (e.g. uptown, downtown or CBD), the subway or other transit system in the urban area. At the mesoscopic level, the utility zones are defined in relation to the proximity of individual subway/transit station in the neighborhood (e.g. a specific connecting bus stop, a parking or commercial mall in the underground city). And, at the microscopic level, the utility zones are defined in relation to various points of interest at the station level (ticketing booth, boarding area, etc.).

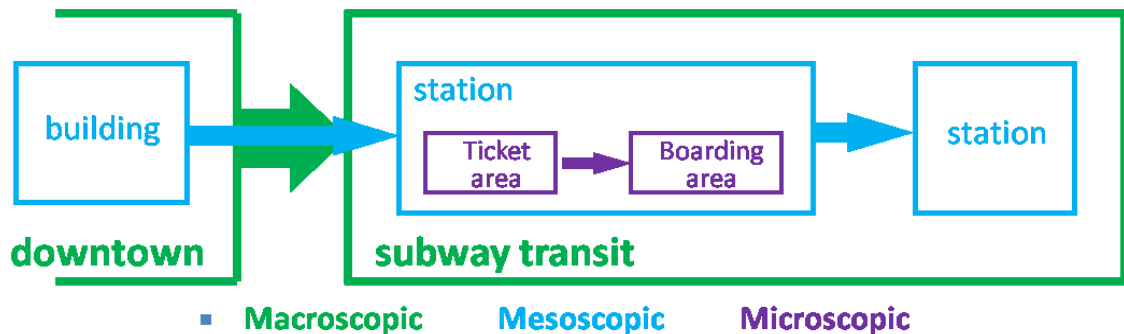

Figure 3.2 Utility Zones at Three Levels of Detail

Two adjacent utility zones sharing the same level of detail are linked by one connector and form a pair of utility zones. A connector represents the access facility (e.g. walking paths, stairs, ramps, trains, escalators) that allows travelers to move from the origin utility zone to the destination utility zone. The destination utility zone in one pair

can also represent the origin utility zone for the adjacent connector. These pairs of utility zone, together with the connectors between them form a unidirectional route during one passenger trip. From the signage system perspective these directional routes are also characterized by the properties (access, egress and transfer traveling scopes) of the carried passenger flows.

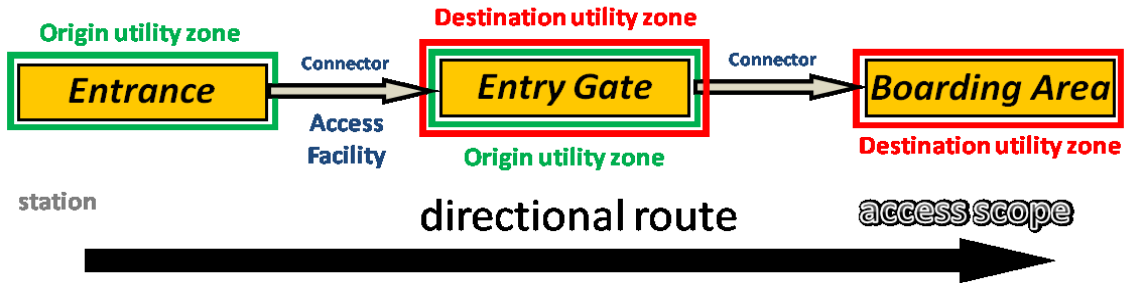

Figure 3.3 Utility Zones in One Traveling Scope

The size of one utility zone and its connector’s feature may vary depending on the level of detail. For example, a train connects two stations, seen as two mesoscopic utility zones. Similarly, an elevator may connect the access area and entry gate, which are examples of microscopic utility zones. In addition, the locations of two utility zones could overlap under different traveling scopes. For example, boarding area (seen as a utility zone for an access scope), and alighting area (seen as a utility zone for an egress scope) are both located on the same platform. Moreover, this definition of utility zone is also applicable for implementation of guidance signs category to other transportation systems (e.g. inter-city railway or civil aviation, where the check-in counters and the waiting halls can be modeled as utility zones). In this framework designed for one subway station, examples of utility zones at microscopic level are shown in Table 3.1.

Table 3.1 Utility Zones at Microscopic Level in One Station

Location	Utility Zone	Travel Scope	Function Description
Entrance/Exit	Access Area	Access	Joint area that gives access to station facilities
	Egress Area	Egress	Joint area that gives access to neighborhood
Hall	Ticketing Area	Access	Area providing ticketing service
	Entry Gate	Access	Area providing access to subway service
	Exit Gate	Egress	Area providing egress from subway service
Platform	Boarding Area	Access	Passenger waiting and boarding
	Alighting Area	Egress	Passenger alighting
	Transfer Area	Transfer	Passenger transferring

As utility zones are determined in the station, guidance signs [G] are divided into three subcategories regarding the wayfinding within each utility zone pair: *Identification Signs* [GI] - signs that identify utility zones; *Direction Signs* [GD] - typically arrow-based signs that display directions toward utility zones; and *Orientation Signs* [GO] - representing the spatial relationship between passengers and the external environment.

The purpose of the identification signs subcategory is solely to identify the physical location of utility zones within the subway spatial reference system. The direction signs subcategory uses arrows to indicate specific directions. It should be displayed continuously along the paths connecting different utility zones, ensuring efficient movement of passengers between utility zones in one zone pair. The orientation signs subcategory illustrates the location of passengers with reference to their surroundings at the same level of detail. The utility zones identified through identification signs should also be represented on the orientation signs. This representation helps passengers in planning the possible routes for their destination

before they refer to the direction signs and start movements. Examples of guidance signs used in practice are illustrated in Figure 3.4.



Figure 3.4 Examples of Guidance Signs (Montreal Metro ©)

Normative Signs

In a subway station the signs that disseminate regulatory information issued by the transportation agency are classified as normative signs [N]. This category of signs is divided into three subcategories: *Operation Information* [NO] - display information with respect to the operating conditions; *Warning Signs* [NW] - advise passengers about potential hazardous conditions; and *Prohibition Signs* [NP] - inform passengers about norms that forbid certain behaviors.

Since normative signs include rules about prohibitive and permissive actions that passengers should observe while taking the subway, these signs could be seen as a potential contract between the subway authority and the passengers, which ensure smooth and safe operation of the system. The types of normative signs could vary depending on the regulations issued by different agencies. Examples of signs from this category are shown in Figure 3.5.

STATION BERRI-UQAM		
	DIMANCHE à VENDREDI	SAMEDI
LIGNE VERTE		
VERS ANGRIGNON		
PREMIER départ	5 h 45	5 h 45
DERNIER départ	0 h 58	1 h 28
VERS HONORÉ-BEAUGRAND		
PREMIER départ	5 h 49	5 h 49
DERNIER départ	0 h 58	1 h 28

a. Operation Information



b. Warning Sign



c. Prohibition Sign

Figure 3.5 Examples of Normative Signs (Montreal Metro ©)

Indication Signs

The third category - indication signs [I], are used to designate and distinguish between various services and facilities within the subway station. Within the indication signs there are two subcategories: *Service Indication* [IS] - to display the services provided in a station; and *Facility Indication* [IF] - to indicate specific facilities in the station.

Indication signs, which are integrated with various physical facilities, show the existence of such facilities. They are indispensable especially when facilities become inconspicuous, either due to positioning behind other objects (e.g. fire extinguisher) or due to parallelism with respect to the passenger movement (e.g. information board). Examples of indication signs used in practice are illustrated in Figure 3.6.



a. Service Indication



b. Facility Indication

Figure 3.6 Examples of Indication Signs (Montreal Metro ©)

Although the above-mentioned subcategories of signs may represent one specific subway system, additional subcategories can be easily incorporated by transportation agencies to evaluate their respective systems. The methodology presented here serves as a basic tool to consistently monitor and evaluate any changes in the existing signage system.

In this stage, all types of signs with demanded and mandatory information are generated and ready for implementation within the subway station. Similarly to the labels, they are going to be marked on the blue print, and this is demonstrated in the next stage.

3.1.3 Stage 3: Signage Implementation

Several generic guidelines regarding the implementation of subway signs are provided in this section. These guidelines are based on individual signage definitions and are independent from the categories they belong to.

Guidance signs are used by passengers to identify the travel routes between utility zone pairs, based on the defined traveling scopes (i.e. access, egress and transfer). For each traveling scope, the implementation of guidance signs is performed by the order of level of detail. That is, first considering the macroscopic level (e.g. between subway system and urban regions or other transit systems), then mesoscopic level (e.g. between station and nearby points of interest), and finally microscopic level, at which most exemplified signs are pertaining to.

Usually the implementation starts with the placement of an orientation sign at the origin zone of the first utility zone pair of one route. This sign could be a map of the station and its surrounding and is necessary to facilitate passengers' awareness about their position in subway station's environment. In addition, by placing such a sign it helps

passengers to plan possible routes through available connectors to the destination utility zone. A poor placement of orientation signs can become a source of congestion for pedestrian flows within the station and reduce the efficiency of passengers' movements through the station. Therefore, the location choice of orientation signs should fully consider the space needed by passengers to stop and study this type of sign, without affecting the regular passenger flow. In addition, in order to account for multiple connections leading to different directions at certain utility zones multiple orientation signs should be set.

After passengers decide about their routes toward the destination utility zone, direction signs distributed along the routes can help them reach their destination. Therefore, direction signs should be presented continuously along the connector from the origin utility zone until the destination utility zone. This helps passengers in determining their location (or confirming their moving direction) thus maximizing the fluidity of passenger movements. In addition, when one origin utility zone is connected to more than one destination utility zones in one traveling scope, direction signs located at the destination utility zones must be extended to the origin utility zone. This optimizes passengers' movements toward their respective destinations.

Another case that should be thoroughly considered for direction signs is when more than one connectors link two utility zones. The placement of direction signs along a route is mandatory at the beginning, the middle and the end of a path, tunnel, stair/escalator, especially for those connectors with long distance, and at the separation and junction points of different routes. This approach keeps reminding passengers' heading direction, and also can avoid the confusion and the hesitation that the passenger

could experience, which generally results in reduced fluidity of moderate and high pedestrian flows.

Identification signs are implemented at the destination utility zone in one zone pair to indicate the destination for passengers. When two or more utility zones with the same traveling function are not spatially adjacent to each other or are not linked by connectors such as tunnels, walkways or stairs/escalators/elevators, more than one identification signs should be used to distinguish between these utility zones. Moreover, identification signs should be set at each position with linked connectors, to clearly identify the destination utility zone for passengers coming from different routes.

This procedure to set guidance signs is repeated until all the signs are implemented to the remaining utility zone pairs. An example of implementation of guidance signs is illustrated in Figure 3.7.

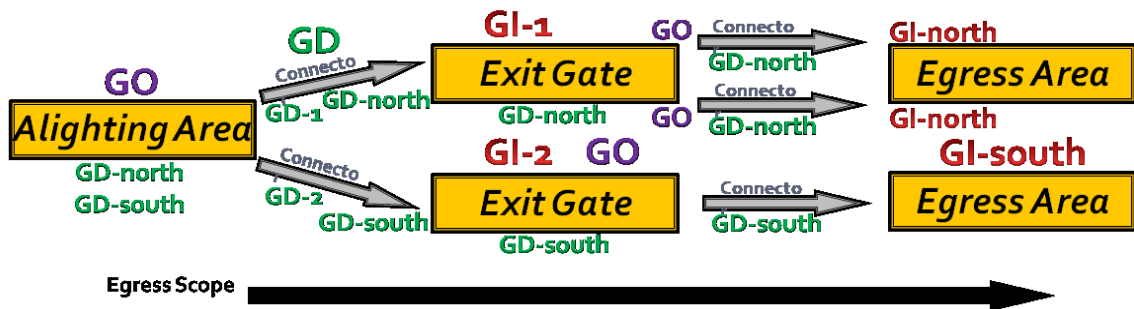

Figure 3.7 Schematic Example of Implementation of Guidance Signs

Normative signs disseminate regulatory information from the transportation authority to passengers at different locations. Therefore, the repetitive display of regulatory information at various positions in the space is important for keeping passengers informed. This type of sign is implemented at station elements that are deemed necessary by the transportation authority (e.g. entrance/exit, hall, platform).

At the entrance area it is expected that signs providing information related to subway operations will be available, such as information about service intervals (first and last arrival time) or ticket fares. This helps passengers to organize their travel plans and to prepare for the subway trip. In addition to the rules applicable to normative signs it is expected that some generic restrictions issued by the subway authority (i.e. smoking prohibition, pets regulation, etc.) should be provided to passengers as they enter the station and at other locations along the passenger's traveling path.

At the hall level (i.e. connecting paths between various utility zones) it is expected that subway operation information is re-presented on information boards, together with orientation signs (e.g. station floor plan). Also, prohibition signs that control for behavioral restrictions are re-displayed as needed (e.g. no roller skating or no skateboard).

At the platform level safety is of utmost importance at all time, especially when passengers are boarding and alighting. Therefore, it is critical to constantly remind passengers about the potential danger of being too close to a platform's edge or to the moving trains. In addition, prohibition signs forbid access past the platform level along the tracks or within special working/maintenance areas should be adequately visible. It is recommended that normative signs be displayed as needed along the connecting routes between utility zones (e.g. "no smoking" signs in path and "mind your hand" sign in the train).

All available services and facilities within the station should be signposted by the indication signs (i.e., this type of sign can be seen as one part of the indicated facilities or services). It is also suggested to corroborate indication signs with orientation signs to

facilitate the passengers' accessibility to existing services or facilities within the subway perimeter (e.g. station floor plan or 3D map). Consequently, it is expected that some subway services or some frequently used facilities will be indicated on the station map (e.g. symbols of customer service and washroom, phone and ATM machine). In addition, when the environment of one location is not readily accessible (e.g. the route to that particular location is long or the visibility of indication signs is impaired due to architectural features), usually more than one signs should be used to guide users to their destinations (Figure 3.8).

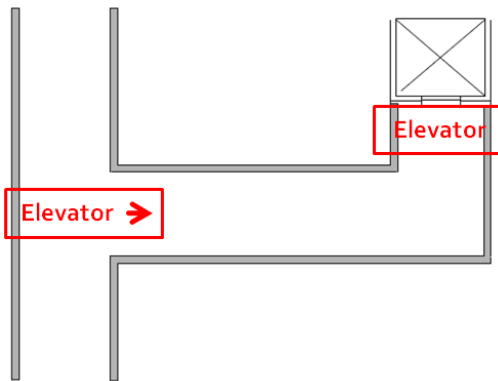

Figure 3.8 Multiple Implementation of Indication Signs

In this stage, signs are implemented within the station systematically. They are considered as the labels that marked to the previously created blue print, ensuring a complete information system without omission and repetition.

3.1.4 Comparison between Existing and Standardized Signage System

As this systematic and standardized signage system is defined founded on the specific conditions of one subway station, a comparison work is made between the existing signs in this station and the standardized signage system, to assess the integration

of signs and demanded information, in other words, examine the deficiency and absence of existing signs and further evaluate the function performance and provide improvement measures.

The comparison is demonstrated in two steps: signage checking and results grading, and regarding to the three categories of signage, respectively. Signage checking is to check the availability of signs as contrast to the defined standardized signage system. Results grading is to grade the deficiency and produce evaluation results of signs with respect to signage types and different locations.

The wayfinding function of guidance signs is realized by the cooperation of a series of signs (orientation signs, direction signs and identification signs), which lead the way in one traveling scope. Hence, for guidance signs, it is not beneficial to check and grade each sign independently. Consequently, checking and grading the guidance signs should be based on the traveling scopes and utility zone pairs in one station. For example, one may organize the checking process between access areas and ticketing area/entry gates in the access scope, and between alighting area and exit gate in the egress scope. This approach is essential to avoid redundancy and repetition, especially in most of the station cases with multiple entrances/exits and platforms.

The integration evaluation of guidance signs for each zone pair can be concluded by one of the assessment results: functional absence, perceptual absence and satisfactory. Functional absence means that there is no guidance sign to refer to, or it is impossible to reach the destination if only rely on the existing signs. This is the most serious condition of signage deficiency and should be primarily considered in signage improvement work. Perceptual absence means that guidance signs are incomplete in

one zone pair, while passenger may still find their way to destination but could with doubt and hesitation. The amelioration on zone pairs with perceptual absence is not mandatory, however it could significantly impact the passenger's readily and friendly traveling activity. Satisfactory means that guidance signs are complete in one zone pair, and passengers should be able to find their way easily and affirmatively. No signage improvement is needed on those zone pairs with satisfactory condition.

For normative and indication signs, the signage checking is based on their possible and necessary presence at different locations (i.e. entrance/exit, hall and platform). It is easy and apparent to illustrate the deficiency of one specific type of sign at one location, further provide suggestions for transit agency's decision on the replenishment of the signs and the amelioration work at one location.

3.2 Visibility Optimization

The passengers receive most of the signage information via visual sense. If one existing sign is unobvious or even invisible to public, the signage information cannot be delivered to the passengers. This is tantamount to the absence of sign and its function. Therefore the signage performance is largely depended on the visibility of signs in practical conditions. Visibility optimization, apart from the information integration of signage system, considers the installation and the setup of available signs in the environment, to achieve passengers' notice and recognition of these signs, ensuring the pass of signage information to the users and realize the signage function.

The principle used to optimize signage visibility is based on the ability of the signs to command attention of the passengers seeking information along the travel pathways (the ability of active presence of one sign). This means that the signs should be

readily accessible to the public via proper design and installation. However, in practice improper settings of one sign could impact its ability to draw passenger's attention and impair its visibility. Basically, the following five major signage attributes are considered to influence signage visibility: color, size, lighting, orientation and height.

The usage of color is a key factor in sign design. Color contrast should be considered between signage content (texts and graphics) and background color of signage panel for information legibility. Also, from the perspective of signage visibility, the dominant color of the sign should stand out from its surrounding environment. Usually the adoption of highlighted color divided from the signage background (e.g. the color of wall or ceiling) is the active measure to draw people's attention and therefore enhance the visibility of signs. Figure 3.9 shows the visual results when different color contrasts are applied. Nevertheless, in some real-world cases one sign could be immersed in the colorful advertisements. This practice should be avoided as much as possible, because the emphasis of signage color is weakened.



a. weak contrast



b. strong contrast

Figure 3.9 Color Contrast between Signage and Background

Normally, it is well accepted that the larger the sign size is, the stronger the visual impact area it could provide at a certain viewing distance. In other words, the visual impact of one certain sign would decrease as the viewing distance increases. Apart from the information volume that one sign contains, it is very important that the design size of the panel itself meets the requirements of basic viewing distance, producing enough visual impact and achieve the active presence. On the other hand, the size of the sign should be large enough to clarify the infrastructure or the area that identified by this sign. For example in Figure 3.10, the sign size should be appropriate to match to the indicated ticket barrier and achieve a balanced visual sense.

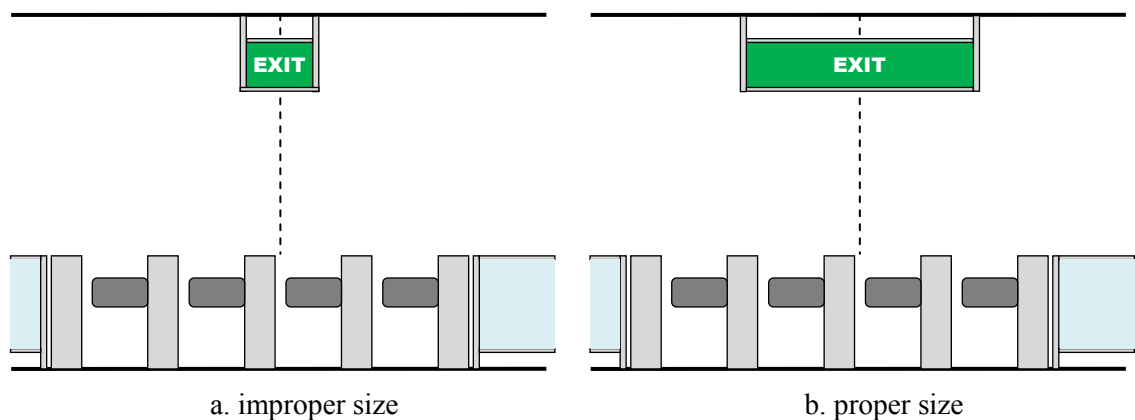

Figure 3.10 Signage Size Affects Visual Sense

Apparently, the ample lighting of the signage is an indispensable element that contributes to the optimization of visibility. Signage lighting generally can be realized via two manners, active lighting by illuminant or passive lighting by reflection. Active lighting is the manner that the sign is lightened by interior light recourse (Figure 3.11a) or the sign is an illuminant itself (e.g. electronic information board). This manner of lighting is mainly used for the emergency signs when the light reflection is not applicable at some special cases (e.g. power failure or fire emergency). Hence all the illuminants

should be under regular operation. Passive lighting is the manner that the sign without any light resource and only can be lightened and seen by light reflection (Figure 3.11b). This manner of lighting usually is adopted on the lighting of the normative and indication signs. So the brightness of the exterior environment is a basic requirement of the signage visibility. In addition the signage surface should be matte to avoid total reflection of lights which could leads to invisible of signage information.



a. active lighting



b. passive lighting

Figure 3.11 Signage Lighting (Montreal Metro ©)

The orientation (facing direction) of one sign should be parallel to the moving direction of passenger flow (i.e. sign panel should be perpendicular to passenger flow), so it follows that the sign panel is completely presented to the passengers with a maximal visual impact area and achieve the optimal visibility. This rule is frequently applied to the guidance signs as this type of signs are serving for the passengers travelling through the station. In addition, when an orientation sign is set at a point serving multiple passenger-flows from different directions, more than one sign panels or a 3D sign should be considered to meet the information demands from all these directions.



a. impaired visibility



b. full visibility

Figure 3.12 Orientation of Sign Panel (Montreal Metro ©)

The height of one sign could be different depending on the particular installing manner in field and the regulations of the subway or transportation authority. For example, in the London underground signs manual, it is regulated that a suspended sign should have a minimal height of 2500 mm and an optimal height of 2700 mm. Similarly, in Beijing subway stations, the recommended height for suspended signs is 2300 mm and 1800 mm for wall-fixed sign. Moreover, the mounting height of one sign should also consider the viewing distance for a universal design. One reference is from the regulations given by the Society for Environmental Graphic Design (SEGD). It considers the relationship between mounting height, viewing distance and character height (Table 3.2 (18)).

Table 3.2 Relationship between Height and Viewing Distance of Signage (18)

Mounting height from floor to character baseline	Viewing distance	Minimum character height
less than 40 in. (1015 mm)	only allowed in elevators	only allowed in elevators
40 in. (1015 mm) to less than or equal to 70 in. (1780 mm)	Less than 72 in. (1830 mm)	0.625 in. (16 mm)
40 in. (1015 mm) to less than or equal to 70 in. (1780 mm)	72 in. (1830 mm) or greater	0.625 in. (16 mm), + 0.125 in. (3.2 mm) per 12 in. (305 mm) of viewing distance above 72 in. (1830 mm)
70 in. (1780 mm) to less than or equal to 10 ft. (3.01 m)	less than 15 ft. (4.57 m)	2 in. (51 mm)
70 in. (1780 mm) to less than or equal to 10 ft. (3.01 m)	15 ft. (4.57 m) and greater	2 in. (51 mm), + 0.125 in. (3.2 mm) per 12 in. (305 mm) of viewing distance above 15 ft. (4.57 m)
greater than 10 ft. (3.01 m)	less than 21 ft. (6.40 m)	3 in. (75 mm)
greater than 10 ft. (3.01 m)	21 ft. (6.40 m) and greater	3 in. (75 mm) , + 0.125 in. (3.2 mm) per 12 in. (305 mm) of viewing distance above 21 ft. (6.40 m)

The performances of these five attributes (color, sign size, lighting, orientation and height) thoroughly affect the accessibility of one sign. The performance failure of any attribute could be the critical factor that impacts the visibility optimization. For example, one indication sign mounted on the wall can hardly be seen along platform if its orientation (i.e. sign's facing direction) is perpendicular to the tracks. Additionally, one direction sign could easily be ignored if its main color blends into the background environment. This type of deficiencies associated with the two types of signs cannot be overcome by good performance of the other attributes. Hence, the attribute mainly responsible for the failure of visibility optimization (e.g. attributes of orientation and

color in the above two cases) is defined as the “critical attribute”, which should be ameliorated primarily during signage improvement measures.

It is prescribed in this study that the performance of one attribute can be graded as “no impact”, “limited impact” or “severe impact” to visibility optimization of the evaluated sign. Therefore for one sign there is one grading result on each attribute performance, and the evaluation result of this sign depends on the performance of the critical attribute.

In practice, only when all the attributes of one sign are graded as “no impact” to visibility optimization, then it is believed that the sign achieves an active presence and the evaluation result is determined as “optimized visibility”. Under this assumption all five attributes are in good performance and none critical attribute is assigned. Consequently, even if only one attribute performance of a given sign is graded as “limited impact” (i.e., the attribute graded as “limited impact” is the critical attribute), still it is considered that the sign has an impaired active presence and the evaluation result is determined as “limited visibility” to public. While if any one attribute performance is graded as “severe affect” or more than one attribute performances are graded as “limited impact” to visibility optimization, we estimate the sign is deficient in active presence and the conclusion is made as “impaired visibility” (Table 3.3). Based on the evaluation results of visibility optimization, the subway or transit authority could improve the signage visibility in a reasonable way (i.e., signs with “impaired visibility” should be treated first).

Table 3.3 Hypothetical Cases of Visibility Optimization Evaluation

Attributes	Sign 1				Sign 2				Sign 3				Sign 4			
	N	L	S	C.A.	N	L	S	C.A.	N	L	S	C.A.	N	L	S	C.A.
Color	×				×				×					×		
Size	×					×		×	×				×			
Lighting	×				×					×		×	×			
Oriention	×				×					×		×			×	×
Height	×				×				×				×			
Evaluation	optimized visibility				limited visibility				impaired visibility				impaired visibility			

Legend: N: No impact L: Limited impact S: Severe impact C.A.: Critical Attribute

3.3 Legibility Standardization

As a basic requirement and necessary principle of visual information design, legibility of signage system is that the signage content (texts or graphics) is displayed in a readable way for passengers' easy understanding. Most of the time passengers are moving during their journey inside one subway station. A good performance of signage legibility prevents passengers' doubt and hesitation when they are reading the signage information, sequentially ensuring a smooth movement of passenger flows without stagnation. This is especially important during peak hours, when ensuring a smooth passenger flow is an important feature for safe subway operation.

In this study the evaluation of legibility performance is demonstrated via the assessment of presentation standardization of information content. In subway station as a public area, the signage system is serving for various groups of people with different backgrounds. The presentation standardization is that the signage information, regarding the font, letter size, color, etc., is displayed in a standard format which fulfills the national or local regulations or criteria, and satisfies the general acquaintance of most passengers. It also could be achieved by the uniform design of signage style for one subway line or

even the whole subway transit system. The uniform signage characters facilitate passenger's familiarity to signage system, help them easily and quickly involved into the new environment. Presentation standardization of information content is a good way to distinguish the transit system from its surrounding interests, or identify one subway line or one specific station via the particular signage representation.

Under different countries with different cultural backgrounds, the formats that are adopted in signage information presentation would be distinct between subway systems. For example the character shape in some Asian countries is always square, differ from the capital and lowercase letters used alternatively in western world; the main color of emergency exit sign is green in Beijing subway system, while in the metro of Montreal, red is chosen as the color acts for the same function. It is incongruous to prescribe one unique format criteria to revise all the subway signage systems. Instead, this study generates some recommended guidelines with respect to typeface, color application and information presentation as general evaluation foundations to support signage legibility standardization.

3.3.1 Typeface

The criteria defined in SEG D's (The Society for Environmental Graphic Design) *the Americans with Disabilities Act: White Paper* (31) states that the required letter body width-to-height ratio is between 0.6 and 1, and the required stroke width-to-height ratio is between 0.1 and 0.2, for the optimized legibility (Figure 3.13).



a. body width-to-height ratio = 0.94 b. stroke width-to-height ratio = 0.14

Figure 3.13 Required Ratio for Legible Typeface (31)

It is recommended the usage of all capital letters should be avoided in the signage text, because usually people are used to the upper- and lower-case words, which are easier to identify. A study by Arthur and Passini (9) suggested that “Good signage letters have an ‘x-height’ to cap-height ratio of at least 3:4”, In other words, when we use upper- and lower-case letters in one word, the height of the lower-case letter (x-height) must be not less than 75% of the upper-case letter (cap-height), as shown in Figure 3.14. The application of this regulation can be seen in the London underground signs manual, which also provides the minimum heights of upper-case letter at different viewing distances (Figure 3.15), and the line spacing based on the height of the lower-case letter (x-height) (Figure 3.16).



Figure 3.14 Height Ratio between Upper-case and Lower-case Letter (9)

Consistent and proper letter spacing is equally important as well since it facilitates passenger’s reading and understanding of the words. Otherwise, especially at a certain distances, narrow letter spacing could affect the correct word identification.

3.3.2 Color Application

Color is a critical element in visual displaying. Color application conducts two aspects of action in signage legibility: color contrast and coding. Color contrast means the sharpness between the text or graphic color and the background color of one sign, differing from the color contrast in signage visibility. Adopting a distinct color contrast facilitates passenger's distinguishing one color from the other, emphasizing the presented information, and further enhancing the legibility.

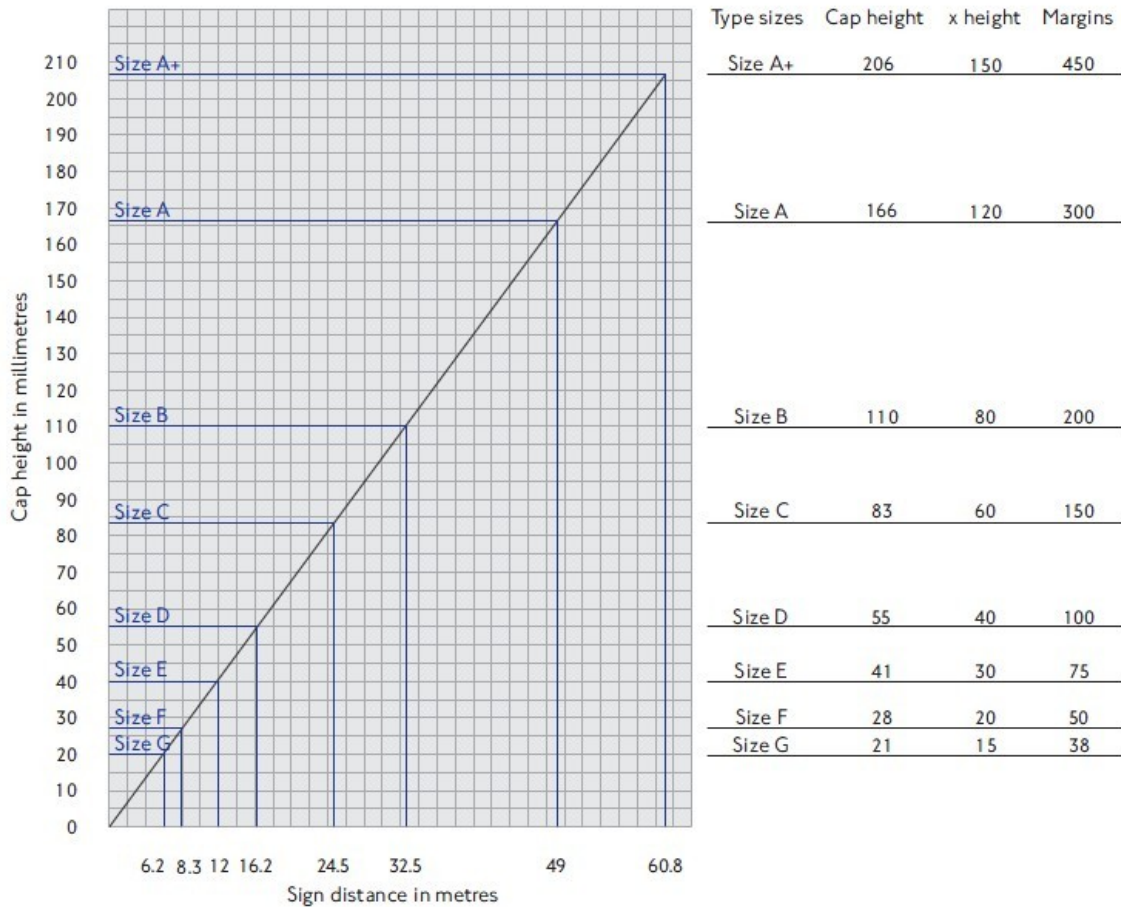

Figure 3.15 Minimum Heights of Upper-case Letter at Different Viewing Distances (29)



Figure 3.16 Line Spacing (29)

It is recommended that the signage content should have a minimum 70% contrast with its background (Figure 3.17 (18)), to achieve for a proper distinction. Meanwhile, the different combinations of two contrasted color could also produce different visual feelings. For example, generally the combination of blue and white makes people feel stable and peaceful; when green is against with white, the first impression gives us is smooth and unobstructed; yellow and black is the highest contrast color combination and is typically used to give critical notification. Nevertheless, sign's main color should be apart from its environmental background, avoiding any possible impaired signage visibility.

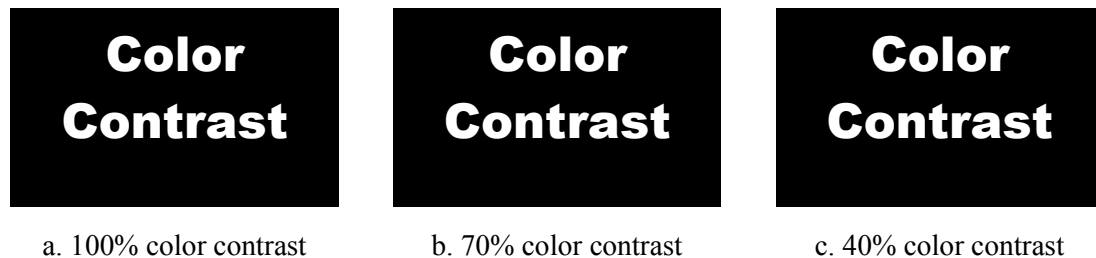

Figure 3.17 Comparison between Different Color Contrasts

Color coding uses one kind of color, to transmit one type of certain information. It is an easy and direct way to transmit information regardless the linguistic and cultural difference. One extensive application of color coding is the color usage in subway line

distinguishing in one subway system. This application presents a uniform color coding on trains, direction signs toward to one subway line, and even the platform decoration. It can help to confirm passenger's location and toward direction only via recognizing color, especially in the transfer subway station with multiple lines coded by different colors. However, the adopted color should be distinct from each other as far as possible, avoiding misleading and confusion of different lines.

Another color coding application is the usage of one kind of color on one particular signage type. Passengers could have different emotional feelings when they see different colors. For instance, the color green and blue make people feel safe and peaceful, while red and yellow color could easily alert people's attention. That explains why in practice red and yellow colors are used to advise for warning and prohibition information, respectively. This manner accelerates passenger's reorganization of signage information at their first sight of the sign.



a. between lines



b. between signage types

Figure 3.18 Application of Color Coding in Practice (Montreal Metro ©)

3.3.3 Information Presentation

A concise, explicit and intelligible information presentation is a vital requirement for signage legibility. Overloaded information on one sign increases the time passenger spends to identify and acknowledge the information needed. Concision requests brief and precise signage information, which could be achieved by exact expressing the words or phrases, and limiting the words number on one line or in one term. Normally the number of words on one line should be less than 5, and acronyms could be considered for long phrases.

When too much information has to be shown on one panel, or the comprehensive presentation of different signs is inevitable at one position, a layered hierarchy ensures the clear and explicit information presentation. Hierarchy of signage content can be realized by adjusting size, using colors, or arranging the content distribution. It usually works well on the identification signs and direction signs, since these signs could contain multiple information units.

For identification signs, if identified utility zones at different detail levels are presented on one panel, the sequence of emphasized utility zones should be from microscopic to macroscopic levels (i.e. the utility zone information at the microscopic level should be firstly emphasized). For example, at one entrance/exit, the egress area name should be presented primarily. Usually larger font size or high-lighted color is used. Then the station name and line name are displayed subordinately (Figure 3.19 a.). For direction signs, it is common to see one panel presented at joint point of passenger flows with multiple directions, and that is sometimes clutter may happen. Two measures to achieve a clear hierarchy here: first, based on people's reading habit (from top to down,

from left to right), the direction information with nearest distance or highest importance should be presented primarily; second, the destination information with different toward directions should be arranged away from each other, usually align left and align right is used on one panel (Figure 3.19 b.). For some cases when identification sign and direction sign are presented at the same time, identification sign owns the higher hierarchy as it fits passenger’s general wayfinding process (Figure 3.19 c.), that is first knowing where they are, then deciding where to go.

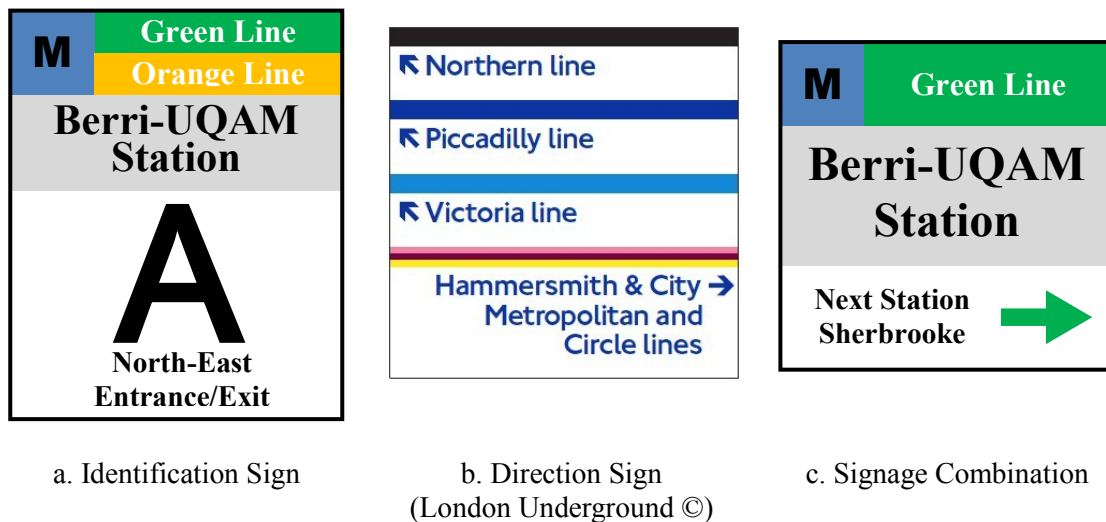

Figure 3.19 Hierarchy in Guidance Information Presentation

In addition, the cooperated usage of symbols or graphics to the text is highly recommended to enhance signage legibility. A well designed symbol has a more direct and clear expression of information than the text does, as the symbol is typically more intelligible to public regardless passengers’ age, education and cultural background. It should be primarily presented (on top or left) to give passenger the first information impression, and followed by the literal explanation as additional assistance for people’s correct understanding. Moreover, the consistent usage of one symbol to deliver the same

information facilitates passenger's familiarity of the signage system. The symbols or graphics used should be part of the national or local standard (Figure 3.20), because randomly created ones may not be accepted by the public and may produce misunderstanding.



Figure 3.20 Standardized Signage Symbols in Beijing Subway (Beijing Subway ©)

Based on these guidelines, some ameliorative suggestions on signage legibility may be proposed to the subway or transit authority as improving measures that should be consulted when upgrading and building a signage system.

3.4 Implementation Flow of Signage Evaluation

This study develops an implementation flowchart for practical application of this methodology (Figure 3.21). For a generic subway station the signage performance evaluation work could be done step-by-step based on this flowchart, and a case study is shown in the next chapter.

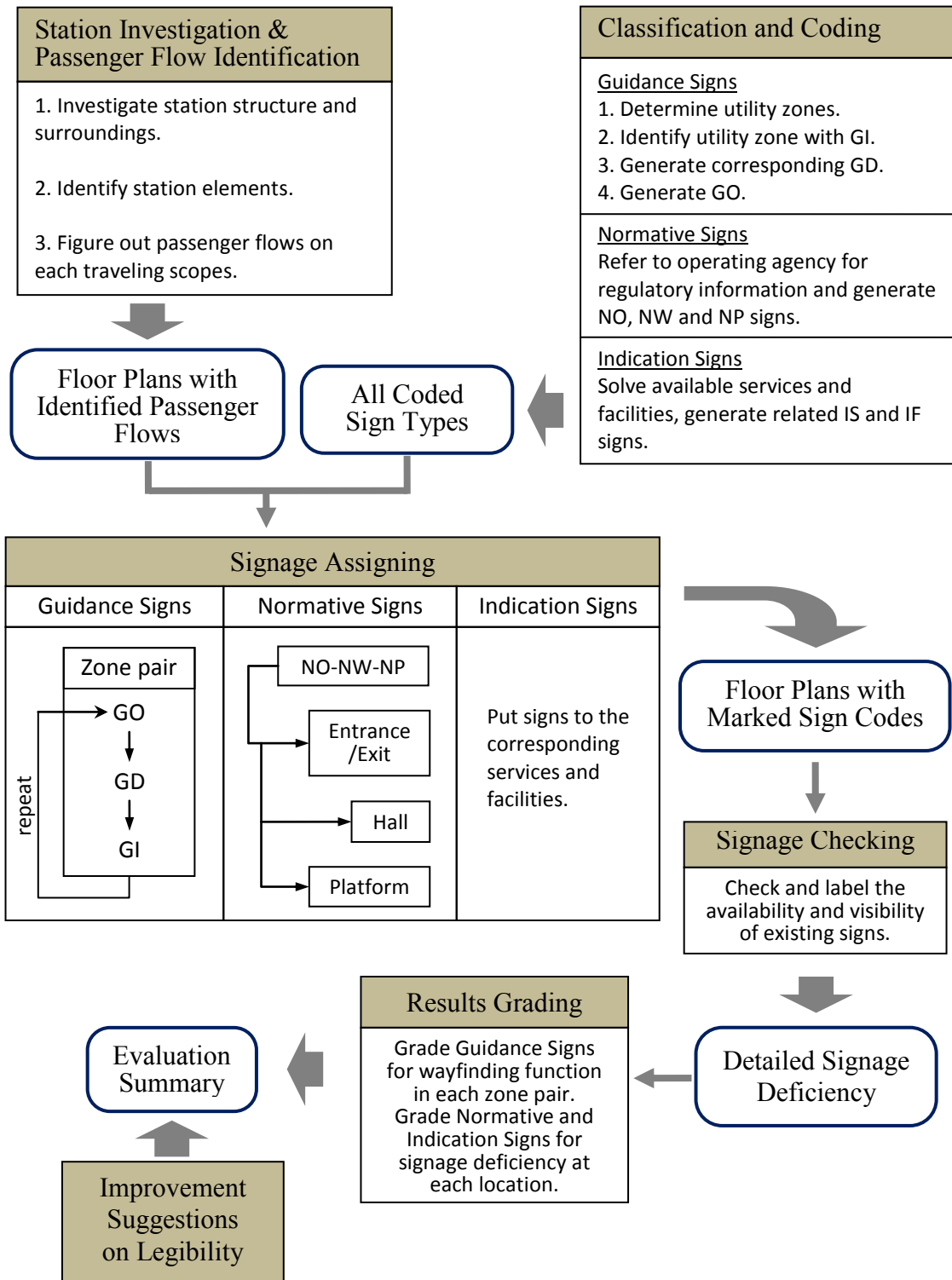

Figure 3.21 Implementation Flowchart of Signage Evaluation

CHAPTER 4

CASE STUDY: BERRI-UQAM STATION

One subway station, Berri-UQAM, of the Montreal Metro system is selected as a case study to apply the methodology described in the previous section. This station, located in the borough of Ville-Marie, is the central station of the system operated by the *Société de Transport de Montréal* (STM). This station connects three lines and is used by nearly 12 million passengers per year (34). It also serves as the main customer service center of STM.

Three lines converge at this station and are color-coded as follows: Green Line runs under Maisonneuve Boulevard, along the northeast-southwest axis; Orange Line runs under Berri Street; and, Yellow Line runs under Saint-Denis Street, the latter two lines are built along an axis perpendicular to the Green Line. There are several major points of interest served by this subway station (e.g. Montreal Central Bus Terminal, Quebec Library, Quebec University at Montreal (UQAM), Place Dupuis Hotel). Also, several STM bus routes serve this area and provide connection for travelers transferring to and from the subway station. In addition, this station features a pedestrian tunnel network that provides direct access from the station to various points of interest within the proximity of the station. Figure 4.1 depicts the layout of the station and its neighborhood.

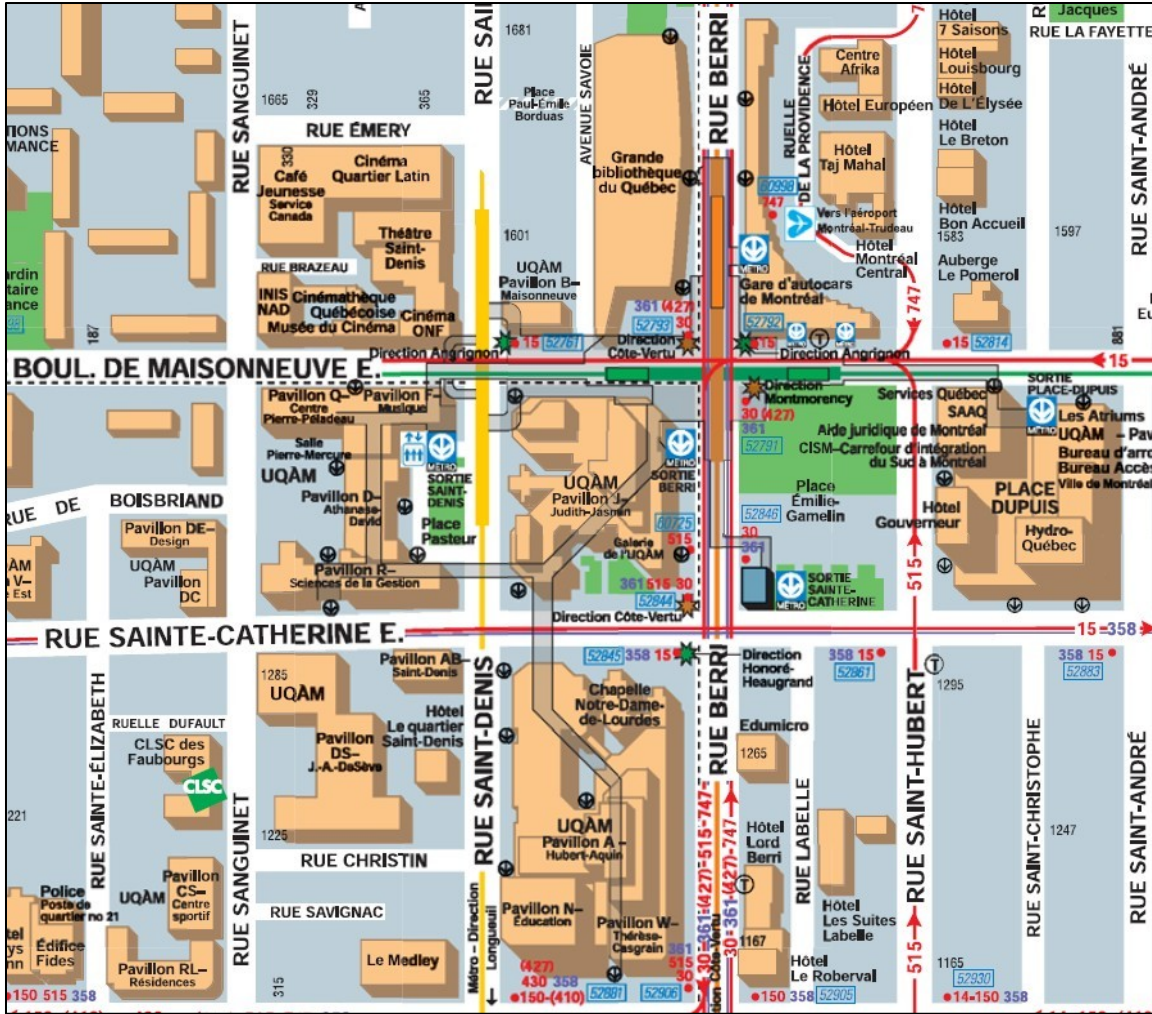

Figure 4.1 Neighborhood Map of Berri-UQAM (Montreal Metro ©)

4.1 Station Investigation and Passenger Flow Identification

The Berri-UQAM station features five levels of access (including the street level) for its travelers (Figure 4.2). At the ground (street) level there are five different entrance/exit doors that give direct access to different streets as follows: Saint-Denis entrance for Saint-Denis Street, Place-Dupuis entrance for Maisonneuve Boulevard, Sainte-Catherine entrance for Sainte-Catherine East Street, Berri entrance and Central-Station entrance for Berri Street. The first underground level contains the central

concourse (hall) where among other facilities the ticketing hall is featured in a rectangular mezzanine with ticketing gates on all four sides. The arms of this mezzanine extend out to all the entrances/exits at ground level, and join the other points of attraction (e.g. the city's main library, the nearby university, hotels) including the underground city (the network of local shops and offices specific to Montreal's lifestyle) as well.

The Orange Line is accessible at the second underground level via stairs and escalators leading from the mezzanine to the train platforms on both sides of this line. The Green Line is accessible at the third underground level, below the Orange Line. The Green Line connects to the Yellow Line which is built in a tunnel at the fourth underground level, a block away along Maisonneuve Boulevard. Travelers can use tunnels, stairs and escalators to reach different levels after they enter the station. The accessibility for persons with limited mobility has been improved with the introduction of an elevator that provides direct access from Saint-Denis entrance to the ticketing hall and to the Orange Line only.

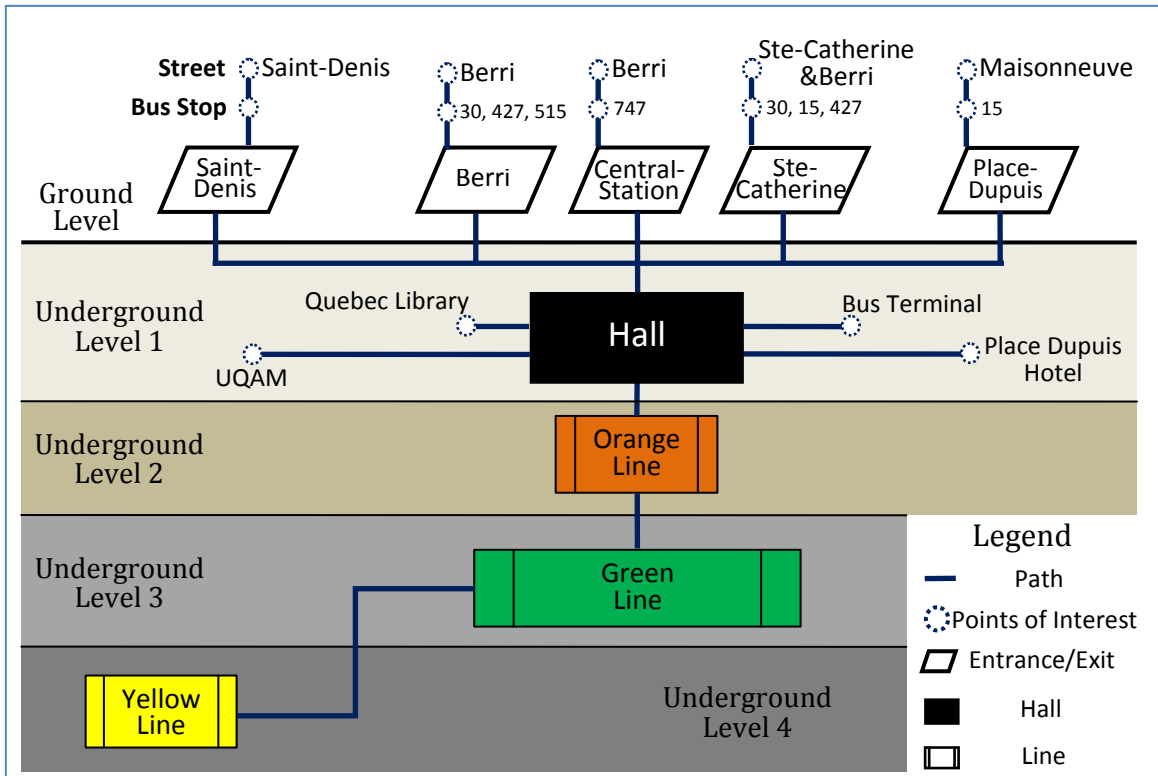

Figure 4.2 Structural Sketch of Berri-UQAM Station

For these floor levels, floor plans are drawn and passenger flows in three traveling scopes (access, egress and transfer) are identified on them. Figure 4.3 shows one example of floor plan with identified passenger flows at hall level (first underground level).

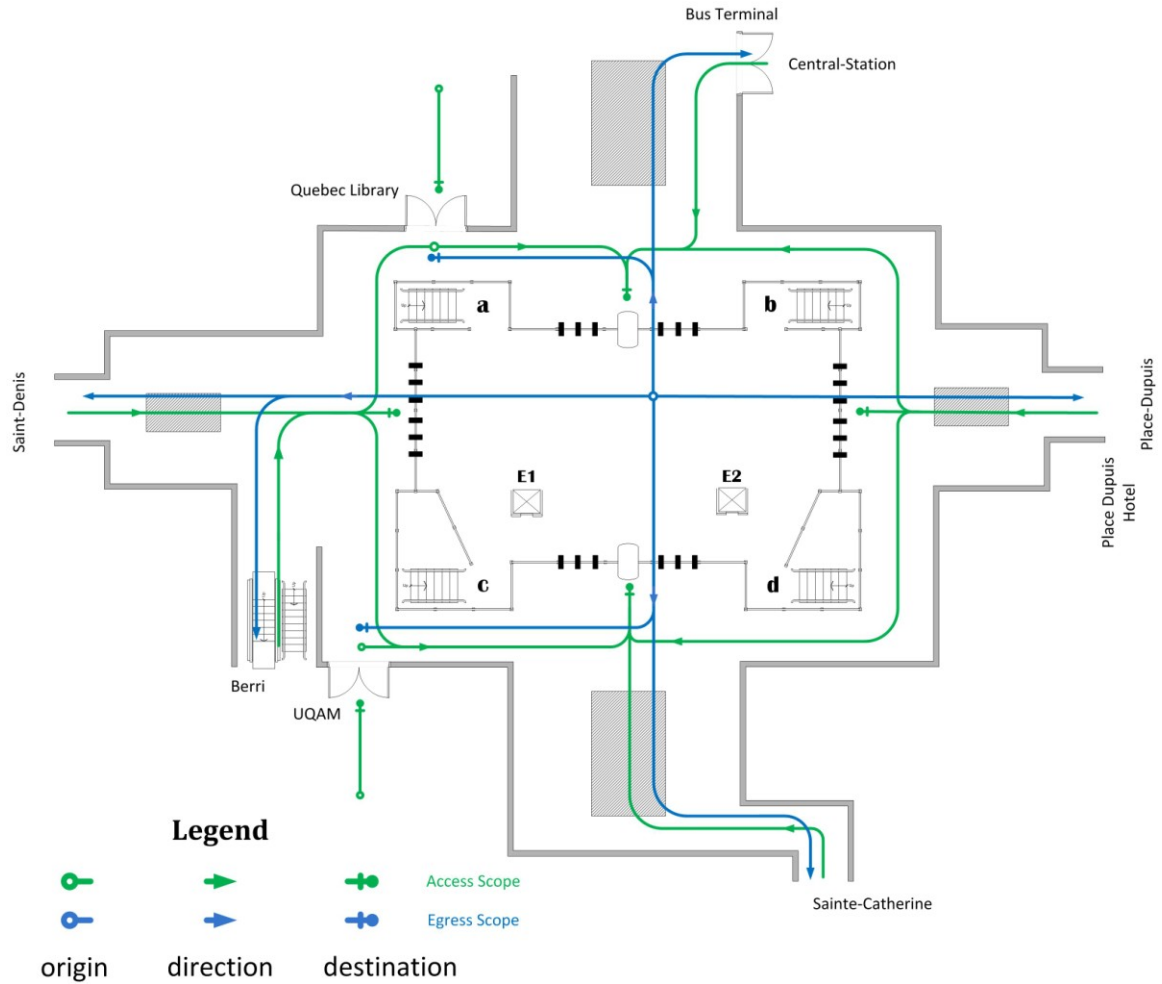

Figure 4.3 Floor Plan at Hall Level

4.2 Signage Classification and Coding

Various types of signs with necessary information are adopted and assigned into different subcategories of guidance signs, normative signs and indication signs in this section. The adoption of signs and their information is according to the actual demand and practical condition of Berri-UQAM station. This process is implemented in each category for a consistent and complete signage system.

4.2.1 Guidance Signs Generation

In order to generate the guidance signs in a subway station the associated utility zones have to be identified. The utility zones of the studied station are identified consistently with the two features specified in the methodology. First, two paired utility zones have to be characterized at the same level of detail. Second, a pair of origin-destination utility zones is characterized by the same traveling scope (i.e. access the subway station, egress from the station or transfer from one line to another). In this study possible utility zones were identified at the Berry-UQAM subway station and they are shown in Table 4.1.

Table 4.1 Utility Zone Determination

Utility Zone				Traveling Scope			Access	Egress	Transfer	Emergency Exit (Egress)				
Level of Detail														
Macroscopic	Urban System	Urban Regions	Mesoscopic	Streets			Points of Interests (origin)	Points of Interests (destination)	n/a	n/a				
				Bus Stops										
				Underground Attractions										
	Subway System	Orange Line		Station	Microscopic	Entrance & Exit	Ground	Saint-Denis	Access Area	Egress Area	n/a	n/a		
								Place-Dupuis						
								Sainte-Catherine						
								Berri						
								Central-Station						
							Underground	Joint Area						
		Hall			Ticket Booth/Machine		Ticketing Area	n/a	Emergency Exit					
					Fare Barrier		Entry Gate	Exit Gate						
		Green Line			Orange Line	Platform	Microscopic	Platform	Orange Line	Montmorency	Boarding Area	Alighting Area	Alighting and Transfer Area	n/a
										Côte-Vertu				
										Angrignon				
					Green Line				Yellow Line	Honoré-Beaugrand				
Longueuil														
Berri-UQAM	n/a*		Alighting Area	Emergency Exit										

*Berri-UQAM is one of the two terminus stations on Yellow Line

The traveling scope is defined by the natural flows of passengers with a specific destination. For example, at the mesoscopic level bus stops, subway stations, or specific building in the proximity of the transit station represent these zones. At the microscopic level, travelers access the system and example of utility zones for this purpose are ticketing area, entry gate, and boarding area. When travelers egress from the transit system, alighting area and exit gate are considered as the corresponding utility zones. In addition, when travelers transfer within the system they also use alighting area and transfer area. The emergency exits are grouped separately into another category of utility zones with exit purpose only activated in special conditions.

Based on the utility zones shown in Table 4.1, guidance signs needed in the station should identify the destination utility zones and provide passengers with guiding (orientation and direction) information, for each type of level of detail and traveling scope.

For identification signs [GI], at the macroscopic level, the *subway symbol* should be available to identify subway service and *line name* sign, identifies different lines in the urban area (access scope). At the mesoscopic level, the *station name* sign should be presented to identify one subway station when passenger access from nearby places (access scope) or when they get off the train from another station (egress or transfer scope), correspondingly the *points of interest* signs are used to identify passengers' destinations of subway trip (egress scope). At the microscopic level, the *ticket service* sign (ticket window or machine) and *entering gate* sign are needed to access to the subway service (access scope), the *platform* sign identifies boarding area with specific train direction of one line (access and transfer scope), and *exit gate* sign and *exit name*

sign ought to identify egress area from subway service and from the station, respectively (egress scope). In addition, particular *emergency exit* signs should be available at the hall level and yellow line to identify the safety exit in emergency situations.

The types of direction signs [GD] correspond to identification signs as they display direction toward utility zones. Therefore, at the macroscopic level there should have *direction to subway* and *direction to line* signs that direct passengers to the subway system (access scope). At the mesoscopic level the *direction to station* signs are necessary to lead passengers to the station and *next station* signs, at the platform level, are guiding direction signs between two stations (access scope). The *direction to points of interest* signs are needed to split passenger flows into different destinations (egress scope). At the microscopic level there should have *direction to ticket service* and *direction to entering gate* signs to guide passengers to ticket purchase and validation to use the subway service (access scope). Also, the *direction to platform* signs, help passenger finding the right train to board (access and transfer scope), and *direction to exit gate* and *direction to exit* signs are needed to lead passengers toward their destinations. The signs that indicate *direction to emergency exit* are needed for a safe evacuation in emergency conditions as well (egress scope).

The orientation signs [GO] serve passengers with three traveling scopes and help them to plan the traveling routes between utility zones. At the macroscopic level, *city map* should be available to help travelers planning their traveling journeys. As at the mesoscopic level the *neighborhood map* is needed for spatial orientation of the travelers with respect to the nearby points of interest, and *subway network/line map* provides information about the subway serviced area (traveler can plan for their subway trip). At

the microscopic level *structural sketch map* of the station or of one building is vital to facilitate passenger's wayfinding in the indoor environment.

All these types of guidance signs are classified in following Table 4.2 and coded for consistent utilization when implementing these signs at various positions on the floor plans within the station.

Table 4.2 Classification and Coding of Guidance Signs

Identification Signs [GI]										
Signs Code	GI-1	GI-2	GI-3	GI-4	GI-5	GI-6	GI-7	GI-8	GI-9	GI-10
Signs Information	Subway Symbol	Line Name	Station Name	Points of Interest	Ticket Service	Entering Gate	Platform	Exit Gate	Exit Name	Emergency Exit
Direction Signs [GD]										
Signs Code	GD-1	GD-2	GD-3	GD-4	GD-5	GD-6	GD-7	GD-8	GD-9	GD-10
Signs Information	Direction to Subway	Direction to Line	Direction to Station/ Next Station	Direction to Points of Interest	Direction to Ticket Service	Direction to Entering Gate	Direction to Platform	Direction to Exit Gate	Direction to Exit	Direction to Emergency Exit
Orientation Signs [GO]										
Signs Code	GO-1		GO-2	GO-4	GO-5					
Signs Information	City Map		Subway Network/ Line Map	Neighborhood Map	Structural Sketch Map					
Level of Detail	Macroscopic		Mesoscopic		Microscopic					
Traveling Scope	Access/ Egress				Access		Access/ Transfer	Egress		

4.2.2 Normative Signs Generation

Different types of normative signs communicate necessary announcements or notices about informative profiles to the passengers. Specific signs inform about the operating conditions, potential hazardous conditions and certain prohibited behaviors in and around the station issued by transportation authority.

In the subcategory of operation information [NO] the following signs should be included to inform operating regulations to passenger. The *operation time* sign, displays

the first and last arrival times for each line, the *fares information* sign, indicates the amount of money passengers have to pay for their subway trip, the *bicycle regulation* sign, informs passengers about bicycle permissive periods (excludes the peak hours). The *next arrival time* displays the estimated arrival time of the next and following trains. The *temporary notification* informs passengers of special management measures in the station (elevator out of order, path block, etc.).

In the subcategory of warning signs [NW], the *danger-high voltage* sign must be available at platforms warning passengers to keep distance to the tracks. The *attention-automatic door* sign should be displayed to remind passengers of automatic door features at specific locations, and *stand clear of the door* sign, which is essential to be displayed on the train door to warn potential hazards when the door is opening and closing.

The type of prohibition signs [NP] in this station ought to mention the prohibited behaviors in the station, such as: *no smoking* sign, to prohibit smoking in the indoor environment, *no entry* sign, to prohibit entering into particular area, *no roller skating* and *no skateboard* signs, to prohibit these activities in a confined area, *no newspaper in the garbage bin* sign, to help recycling. In general, the types of normative signs may vary depend on the prohibited behavior types prescribed by different agencies.

4.2.3 Indication Signs Generation

The available services and facilities at the Berri-UQAM should be denoted by indication signs. Currently, the necessary service indication [IS] signs contain *STM customer service* and *STM security* ones. With respect to the emergency related facilities in the station, the *SOS assistance* indication sign should be available to indicate the emergency phone and fire extinguisher. Other facilities/feature signs are the ones for the

public phone, ticket machine and ATM machine. The *elevator* sign is important to indicate the accessibility facility between hall and orange line level, the grouped guiding and operation information should be denoted by *information board* sign, and the *seats for passenger in need* signs is used to indicate the reserved seats for particular users.

The classification of indication signs depends on the services and facilities that a station obtains. All the signage types and coding of normative and indication signs for Berri-UQAM are illustrated in Table 4.3.

Table 4.3 Classification and Coding of Normative and Indication Signs

Subcategory	Signs Code	Signs Information
Operation Information [NO]	NO-1	Bicycle Regulation
	NO-2	Operation Time
	NO-3	Fares Information
	NO-4	Next Arrival Time
	NO-5	Temporary Notification
Warning Signs [NW]	NW-1	Danger-High Voltage
	NW-2	Attention-Autodoor
	NW-3	Stand Clear of the Door
Prohibition Signs [NP]	NP-1	No Smoking
	NP-2	No Roller Skating
	NP-3	No Skateboard
	NP-4	No Newspaper in Garbage Bin
	NP-5	No Entry
Service Indication [IS]	IS-1	STM Customer Service
	IS-2	STM Security
Facility Indication [IF]	IF-1	SOS Assistance
	IF-2	Public Phone
	IF-3	Ticket Machine
	IF-4	ATM Machine
	IF-5	Information Board
	IF-6	Elevator
	IF-7	Seats for Passenger in Need

4.3 Signage Assigning on Floor Plan

This section presents the ideal implementation of previously adopted types of guidance signs, normative signs and indication signs at Berri-UQAM station. This process is executed on each category of sign under the corresponding guidelines as defined in the methodology. And final floor plans of each station level with assigned signs are generated as a proposed standardized signage system for Berri-UQAM.

4.3.1 Guidance Signs Implementation

Via applying the implementation guidelines as described in the methodology, recommended layouts of guidance signs at the station for access and egress scopes were created. These layouts are depicted in Figure 4.4 and Figure 4.5, respectively, with detailed explanations provided below.

With respect to the access scope a macroscopic zone pair is identified between urban region or other transit system and subway system. Hence, the city map [GO-1] has to be placed in the surrounding origin utility zone (i.e. points of interest) of subway system at ground level (e.g. street or other transit station). Before the *subway symbol* [GI-1] and *line name* [GI-2] are displayed to help travelers identify the subway system and its access area as the destination zone, a set of corresponding direction signs (i.e. *direction to subway* [GD-1], *direction to line* [GD-2]) should be placed between different points of interest and the access areas.

At the mesoscopic level, the first zone pair is between points of interest (street and bus stop at ground level or building and mall at underground level) and the subway station. Therefore *neighborhood map* [GO-4] is placed at points of interest of the station at street or other transit station, while *structural sketch map* [GO-5] of one building is

placed at the underground points of interest. Then it follows the *direction to station* [GD-3] and *station name* [GI-3], which also has to be shown at the access area.

The second zone pair at the mesoscopic level is between this station and another station, so there should be a *subway network/line map* [GO-2] presented to passengers once they enter to the station (access area). And at platform (boarding area) there should be *next station* [GD-3] and *subway network/line map* [GO-2] available to confirm passenger's selected destination (sometimes this type of sign could also be seen in some subway systems in a dynamic electronic format showing the progress of the train through the network).

At microscopic level within the station, two zone pairs are defined between the access area, ticketing area and entry gate, and the boarding area. The *structural sketch map* [GO-5] of the station is displayed in the access area. Next, the signs for *ticket service* [GD-5] and direction to *entering gate* [GD-6] have to be displayed. These signs lead to the ticketing area and entry gate, which are identified by *ticket service* [GI-5] and *entering gate* [GI-6] signs. At the hall level the *structural sketch map* [GO-5] is presented in the origin zone of next zone pair, paired with boarding area as destination zone. Consequently, the *direction to platform* [GD-7] signs need to be placed on all the connectors (walking paths) linking to the five boarding areas (Yellow Line only has one boarding area as the Berri-UQAM station is one end of this line). The boarding areas are identified by separate *platform* [GI-7] signs.

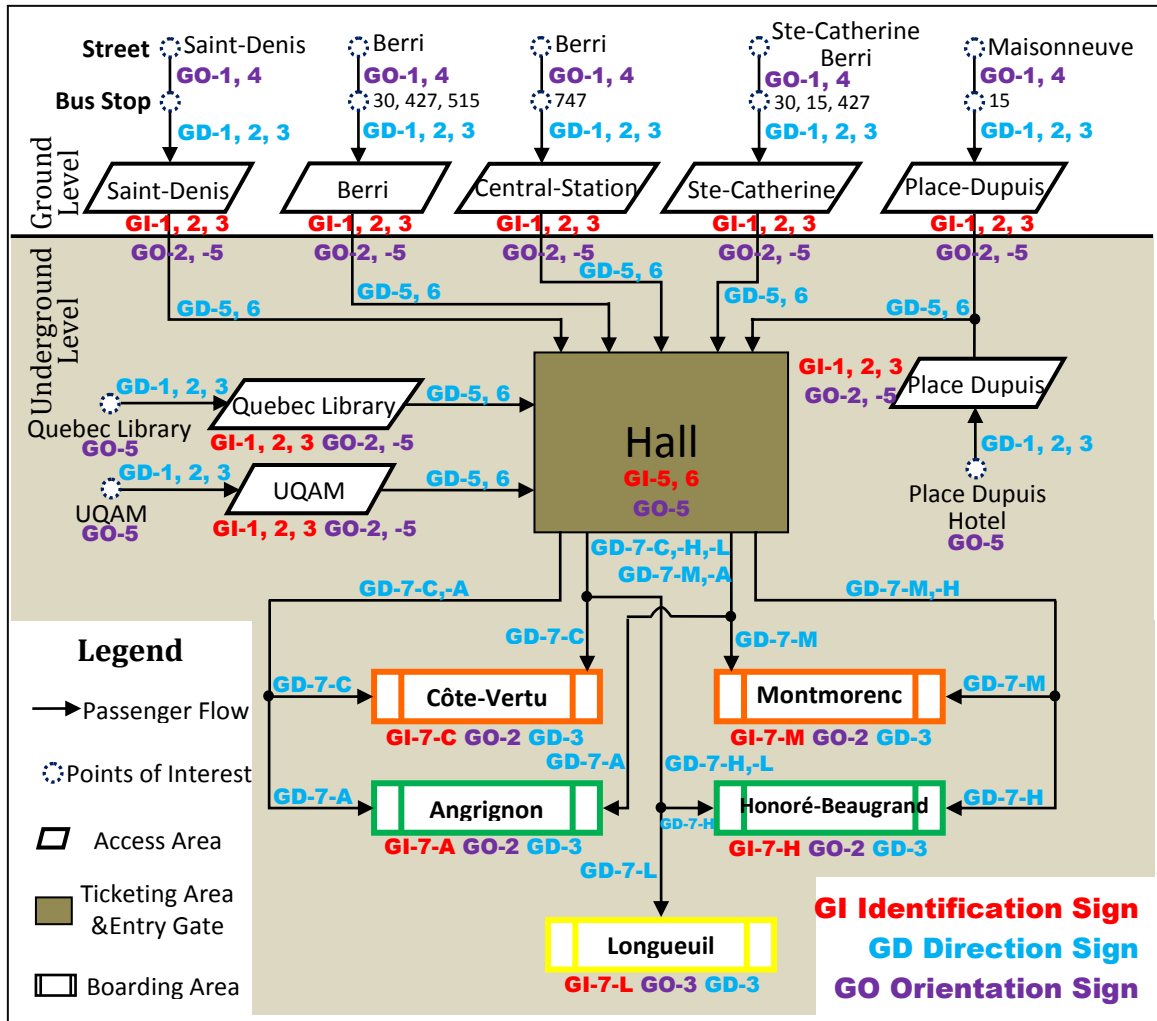

Figure 4.4 Layout of Recommended Guidance Signs Implementation for Access Scope

With respect to the egress scope, at macroscopic level city map [GO-1] is placed at the egress area since it is the origin from subway system to next journey.

At mesoscopic level, first at the platform (alighting area) the *station name* [GI-3] identifies the station (destination utility zone) of the zone pair between two subway stations. While in the zone pair between station and surrounding points of interest, at the surface egress area *neighborhood map* [GO-4] has to be presented for passengers' convenience as they are leaving the station. It is recommended that the *direction to points of interest* [GD-4] sign and the *points of interest* [GI-4] sign should be assigned

until passengers reach their destinations, even though both these kinds of signs presumably will be placed outside the subway authority's jurisdiction. When the egress area is at underground level connecting to one building, these two types of sign would be necessary to lead the way at hall level, followed by a *structural sketch map* [GO-5] sign of the adjacent building.

At microscopic level, the zone pairs are between alighting area, exit gate and the egress area. The *structural sketch map* [GO-5] signs are displayed at the alighting areas, for each platform, followed by the *direction to exit gate* [GD-8] sign from alighting area to the exit gate, which is identified by the sign *exit gate* [GI-8] in the hall. Passengers would be informed through the *neighborhood map* [GO-4] and be able to decide which exit is closest to their destination. Then, passengers plan their exit routes on the *structural sketch map* [GO-5] and they should be able to follow the *direction to exit* [GD-9] signs to reach their destinations.

Each egress area needs to be identified separately by *exit name* [GI-9] since they are not directly connected. Because the zone exit gate is connecting to multiple egress areas, the direction signs at egress areas (e.g. *direction to points of interest* [GD-4]) should also be shown at hall level after passengers exit from the ticket barrier. Moreover, *emergency exit* [GI-10] and *direction to emergency exit* [GD-10] should be visibly displayed for the available emergency exit facilities.

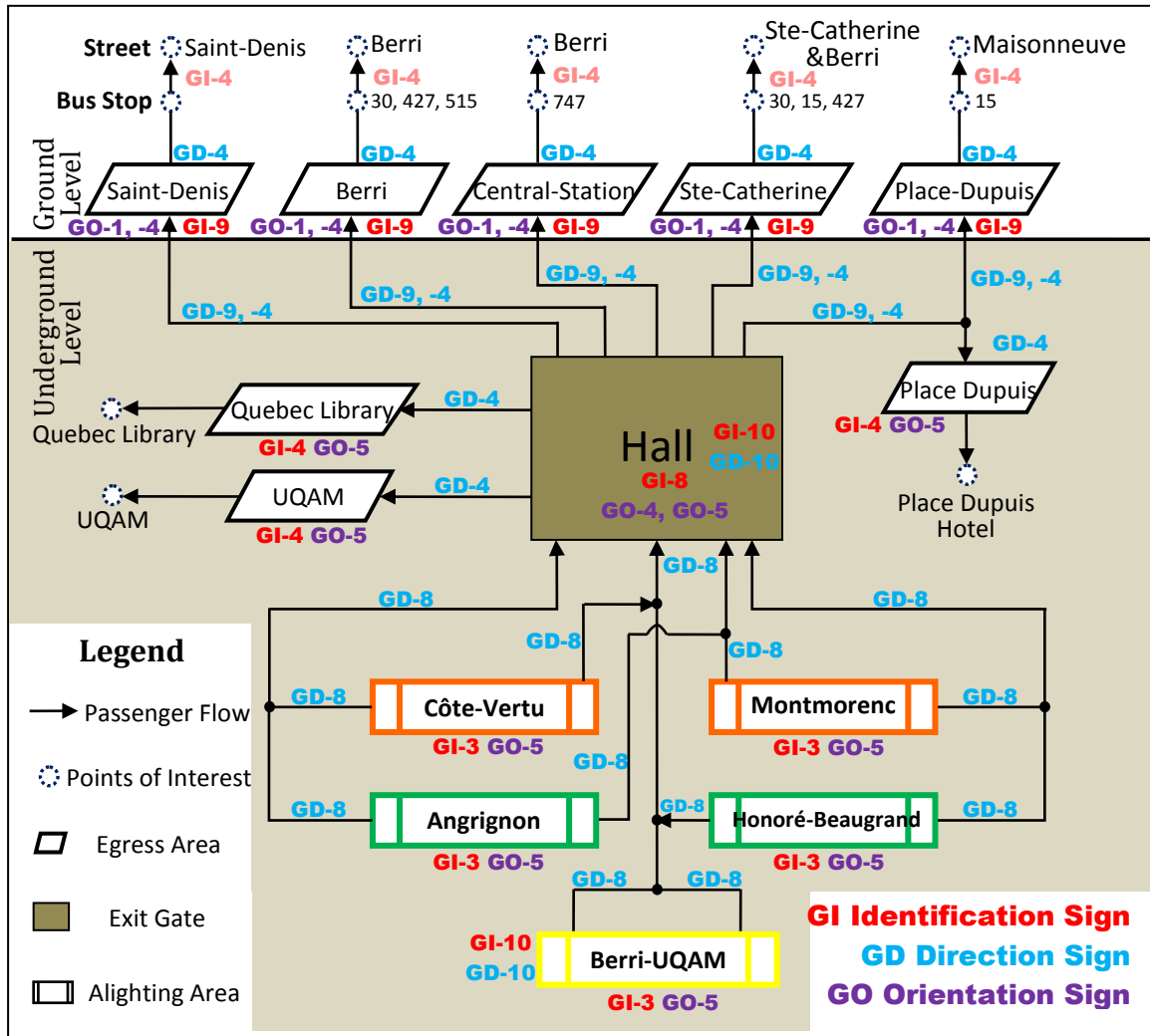

Figure 4.5 Layout of Recommended Guidance Signs Implementation for Egress Scope

Lastly, the same methodology is applied to the transfer scope. At the microscopic level signs of *platform* [GI-7] identify each boarding area in access scope also serve for the transfer scope as an identification sign at destination zone in the zone pair between platforms. *Structural sketch map* [GO-5] is presented in alighting area before they refer to *direction to platform* [GD-7] signs. These signs should be placed continually from one alighting area of one line to the transfer areas of the other lines only served for transfer purpose.

4.3.2 Normative Signs Implementation

According to the structure feature of Berri-UQAM and the required regulatory information issued by STM, normative signs should be displayed at different locations (i.e. entrance/exit, hall, and platform) and along the connecting paths between them.

Currently, at each entrance/exit, there should have *bicycle regulation* [NO-1], *operation time* [NO-2] and *fare information* [NO-3] presenting the subway service information; *attention-autodoor* [NW-2] on the revolving door; and *no smoking* [NP-1], *no roller skating* [NP-2] and *no skateboard* [NP-3] presented immediately after passengers enter the station. Subway service information [NO-1, NO-2 and NO-3] and *no smoking* [NP-1] need to be repeated in the hall. In addition, *no newspaper in garbage bin* [NP-4] should be presented on each garbage bin. On the platform level there should have *next arrival time* [NO-4] shown on several screens, *danger-high voltage* [NW-1] on the tracks and *no entry* [NP-5] on the barriers at the two ends of the platform that give access to the tunnel facilities. *No smoking* [NP-1] is also displayed at the platform level. The sign *stand clear of the door* [NW-3] ought to be shown on the train's doors. In addition, it is recommended that *temporary notification* signs [NO-5] are displayed at various locations when needed.

4.3.3 Indication Signs Implementation

Services and facilities available at different locations should be indicated by their corresponding indication signs. Moreover, some regularly referred services and essential facilities are recommended to be indicated by more than one sign if necessary, or to be presented on the *structural sketch map* [GO-5] for passenger's easy accessing. As a

consequence, the recommended implementation of normative signs and indication signs in Berri-UQAM station is illustrated in the Table 4.4.

Table 4.4 Implementation of Normative and Indication Signs

Subcategory	Signs Code	Signs Information	Location			
			Entrance/Exit	Hall	Platform	Connector
Operation Information	NO-1	Bicycle Regulation	√	√		
	NO-2	Operation Time	√	√		
	NO-3	Fares Information	√	√		
	NO-4	Next Arrival Time			√	
	NO-5	Temporary Notification	√	√	√	√
Warning Signs	NW-1	Danger-High Voltage			√	
	NW-2	Attention-Autodoor	√			
	NW-3	Stand Clear of the Door				√
Prohibition Signs	NP-1	No Smoking	√	√	√	√
	NP-2	No Roller Skating	√	√		
	NP-3	No Skateboard	√	√		
	NP-4	No Newspaper in Garbage Bin	√	√	√	√
	NP-5	No Entry			√	
Service Indication	IS-1	STM Customer Service		√		
	IS-2	STM Security		√		
Facility Indication	IF-1	SOS Assistance		√	√	√
	IF-2	Public Phone	√	√	√	√
	IF-3	Ticket Machine		√		
	IF-4	ATM Machine		√		
	IF-5	Information Board		√		
	IF-6	Elevator	√	√	√	
	IF-7	Seats for Passenger in Need				√

All these signs are assigned to the floor plans at corresponding positions, and one example can be seen in the figure below. The floor plans with marked signage codes are ready to be checked and graded for the evaluation of information integration and visibility optimization.

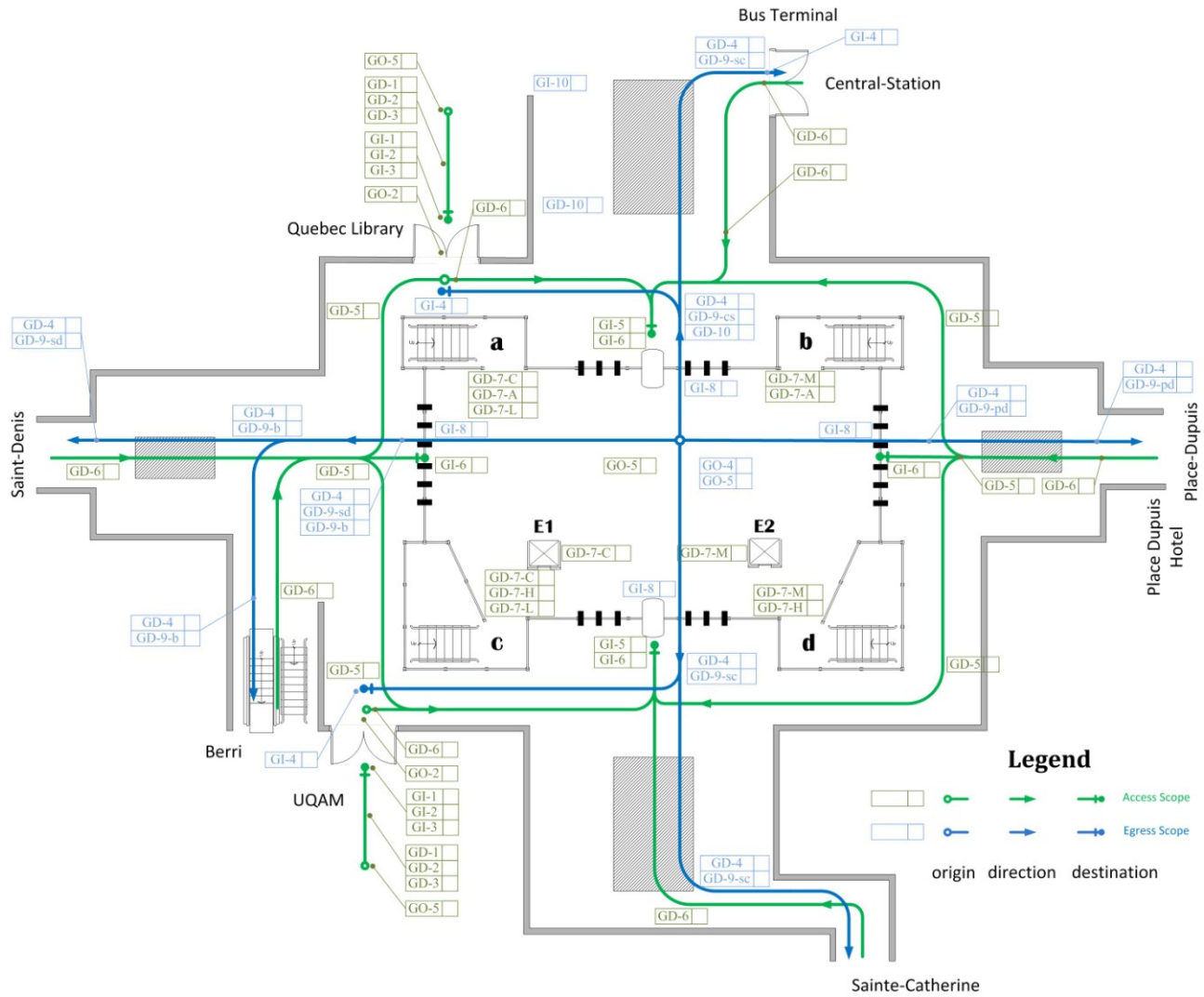

Figure 4.6 Example of Floor Plan at Hall Level with Marked Signage Codes

4.4 Signage Performance Evaluation

The subway signage performance evaluation work in practice should include the signage checking and results grading of the two evaluation aspects - information integration and visibility optimization. Also, it should make recommendations on improving the third performance aspect - legibility standardization.

4.4.1 Signage Checking

At the signage checking step the operator has to go to the station with all the floor plans marked with signage codes (i.e., the proposed standardized system), checking the availability of existing signs contrast to the signs on floor plans, and checking the visibility of those available signs.

The signs with different checking results (optimized visibility, limited visibility, impaired visibility or unavailable) are marked by different symbol next to the corresponding sign codes on the floor plans. Appendices I shows the detailed checking results of Berri-UQAM station.

4.4.2 Signage Evaluation (Grading) Results

The evaluation results are summarized in some forms as illustrated in Appendices II. For normative and indication signs, the signage deficiency (number of absent signs and signs with affected visibility) is presented on each signage type at different locations. Besides, the function performance (wayfinding function) of guidance signs is evaluated in each zone pair (functional, perceptual absence or satisfactory), and affected passenger flows are displayed on floor plans as well.

Transportation authority could determine necessary improvement or enhancement of one type of signs at particular locations, based on the grading forms and detailed floor

plans. Effective and pertinent measures could be adopted to resolve the problem without affecting the regular information service of other types of signs in the station.

4.4.3 Recommendations Pertaining to Signs Legibility

Based on the observation and analysis of some existing signs in Berri-UQAM station, drawbacks are revealed and pertinent recommendations are raised on the legibility of signs. Here are some actual signage conditions in the station.

Most of the guidance signs in station are installed on a size-standardized light-box (Figure 4.7). However, the panel size is always the same regardless the information content on it. As a direct consequence is that some words or symbols may become too small, for example when there is too much content on one panel (Figure 4.7 a). Hence, it is uneasy for the passenger to read the text. In addition, the symbol losses its ability to transmit direct and clear information on passenger's first impression. Another consequence of using this type of panel is that the letter spacing is inconsistent (i.e., more letters there are on one panel, the narrower the spacing is, Figure 4.7 b).

Other observed deficiencies are related to the color contrast. Currently, the adopted text color is white and signage background color is black on some guidance signs. However, if the inside lighting resource breaks down, the signage information is hardly visible due to the black background panel (Figure 4.7 c). To resolve these problems, first the signs should be removed from light-boxes, since standardized light-box directly limits the size of signage panel. Besides, alternative colors and installing manners (wall or pole mounted) might be considered by the operating agency, to establish a separate and independent signage system apart from other existing facilities.



a. Letters too Small



b. Inconsistent Letter Spacing

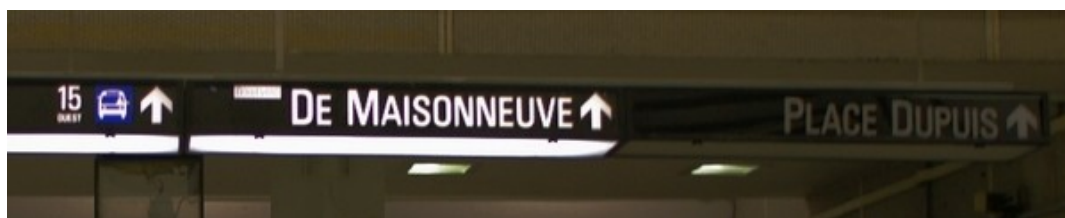

c. Low Reflection of Black Background

Figure 4.7 Existing Guidance Signs Installed on Light-box (Montreal Metro ©)

At some passenger flow diverging points the direction signs leading to different directions lack the appropriate hierarchy. Here are two examples: according to the sign showed in Figure 4.8 a, when passengers read signage information from left to right, they may think that the central station is on the left way, because the phrase “*STATION CENTRALE D’AUTOBUS*” follows the “*GRANDE BIBLIOTHÈQUE*”, which is indicated by a left arrow; in Figure 4.8 b, three destinations are indicated by two arrows, the right one “*TERMINUS D’AUTOBUS*” has no direction arrow. Hence passenger might hesitate that is the bus terminal also on left way, or is it on right way while one right arrow is missing. In these cases direction signs should be separately displayed, and one arrow is enough for multiple destinations with the same heading direction. Figure 4.9 gives suggested signage layout for these two examples.



a.



b.

Figure 4.8 Examples of Bad Hierarchy (Montreal Metro ©)

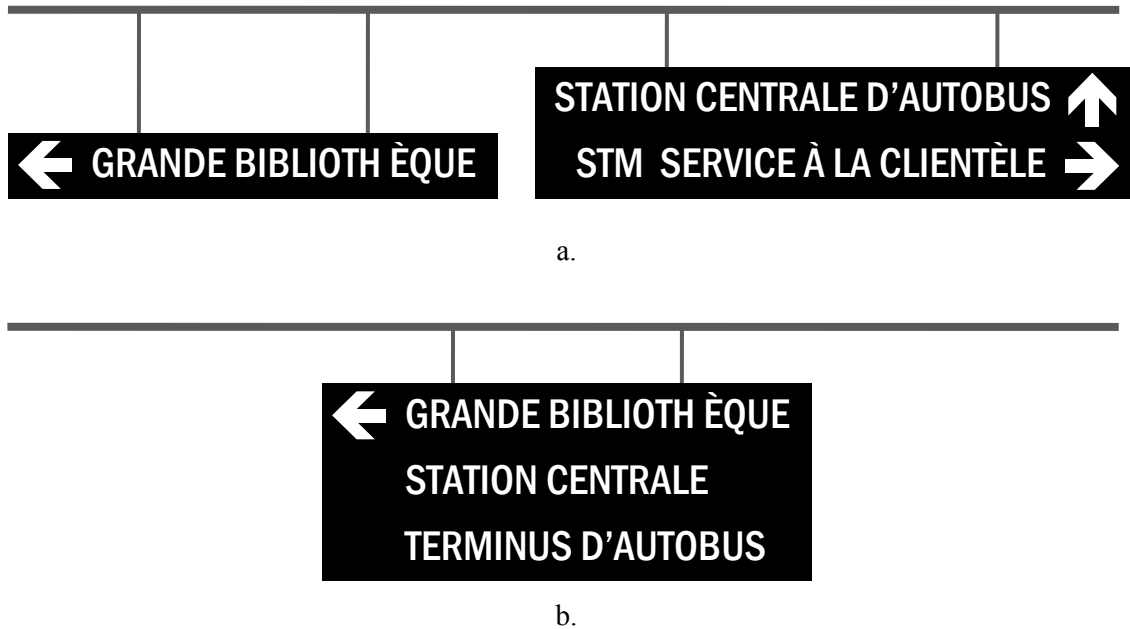

Figure 4.9 Examples of Suggested Signage Layout

Some other defects are illustrated in Figure 4.10. For example, all capital letters are widely used in the signage text, even on the orientation signs (Figure 4.10 a), which should be avoided. Also, there are two types of No Smoking sign presented at orange line (Figure 4.10 b). The old ones should be replaced by the new ones from the national or local standard. Additionally, at the platform level advertising panels weigh more than the signs indicating the station name (Figure 4.10 c). In this case, the problem could be corrected by at least separating the two types of panel or by highlighting the station name using one unique color, to be used consistently in the station, and which should not appear in the ads as far as possible.



a. All Capital Letters in Text



b. Inconsistent Signage Types



c. Cluttered Advertising

Figure 4.10 Other Defects on Legibility (Montreal Metro ©)

CHAPTER 5

CONCLUSIONS AND FURTHER WORK

5.1 Summary

In this day and age, subway system is increasingly important in large urban areas for people's daily traveling. The signage system within one subway station, as a requisite information facility provided for passenger's journey, plays a key role in the subway smooth operation. This study establishes a framework to comprehensively evaluate the signage performance, reveal signage deficiency and provide a basis for further improvement measures. The performance evaluation work of a signage system is carried on from three aspects: information integration, visibility optimization and legibility standardization.

The first aspect, information integration, intends to examine the absence of signs at various locations, ensuring the information transmitted from signage system is complete, which is also an elementary requirement of signage system. To achieve this goal, a comparison work is performed between the existing signs in station, and a proposed standardized signage system, which is defined in three stages. In the first stage station elements and passenger flows are identified within the station. Stage two sorts and defines all the signs into three signage categories (guidance signs, normative signs and indication signs) and their subcategories. Additionally, a new concept of utility zone served for classification and definition of guidance signs is introduced in this stage. This concept is also applied in the implementation of guidelines signs in stage three, signage

implementation, in which stage guidelines are raised for a systematic signage implementation of the three signage categories.

The purpose of second evaluation aspect, visibility optimization, is to ensure that all the available signs are set and installed in a proper way to maximize visibility. Signs' invisibility or inaccessibility represents major cause of the signage function absence. Five signage attributes, color, panel size, lighting, orientation and height, are chosen as the evaluation factors to assess the ability of the signs to command attention of the passenger. Moreover, critical attribute is defined to character the attribute that predominantly trigger the negative result of visibility evaluation. This visibility evaluation of one sign can be estimated as optimized visibility, limited visibility or impaired visibility, according to the performances associated with the five signage attributes.

Last but not least, passengers ought to read and understand signage content easily and correctly. This defines the principle of legibility standardization. Some guidelines regarding signage typeface, color application and information presentation are provided as generic basis for recommendations on legibility.

In practical application, an implementation flowchart covering the above three evaluation aspects is developed for operation agency to execute the signage performance evaluation work. In this study, the largest subway station from Montreal's subway system, Berri-UQAM, is selected as a case study to demonstrate the applicability of the proposed methodology. The evaluation results are presented via the format of some designed evaluation forms. These forms focus on facilitating the improvement of one

type of sign at one particular location, based on the station floor plans with detailed signage deficiency.

It can be summarized from the evaluation results that for information integration the major issue is the absence of direction signs at various locations. For instance, there is no direction signs available (GD-1, GD-2 and GD-3) leading the way toward Berri-UQAM station. Also at hall level, the station is deficient in terms of direction signs GD-5, GD-6 and GD-9, in both access and egress scopes. Besides, orientation signs (GO-5) should be displayed at each platform levels, and corresponding indication signs should be designed and added to signage system for denoting the information board, ticket machine and etc.

The deficiency of signage visibility is mainly related to the lighting problems, either the breakdown of lighting resource (light-box) or insufficient lighting environment (e.g. at platforms). In addition, warning signs (NW-1) placed on tracks loss the function since their color is merged into the background; and the panel size of IF-1 and IF-2 sign is not big enough for the signs to be seen along the platform.

Regarding the signage legibility, color coding is well-applied in this station, but a separate and independent signage setting and installation approach might be considered to resolve the issues in terms of inconsistent typefaces and cluttered information presentation.

5.2 Concluding Remarks

This study identifies three aspects - integration (i.e., availability), visibility and legibility - of the signage system as step-by-step principles to comprehensively evaluate the signage performance in one subway station. The performance evaluation is

demonstrated progressively and separately on these three signage aspects. On one hand, only when the basic requirement of signage availability is fulfilled, then the visibility evaluation is significant for those available signs, and lastly the legibility evaluation ensures the most efficient performance of the visible signs. On the other hand, the evaluation failure of any aspect (information unavailable, inaccessible or unreadable) could affect signage function of information communication and further produce inconvenience for the passengers. Therefore, these three aspects can be considered as generic performance indexes for signage system evaluation, not only in subway station, but also can be served for any signage system in real-world.

The evaluation of information integration is performed based on the standardized signage system of one station. The three-stage definition methodology for this standardized signage system, clearly gives the answers to the design and planning of signage system, regarding to where (to set signs), what (signs to be set) and how (to set signs). Especially the new created concept of utility zone facilitates the definition and implementation of guidance signs, which are essential in signage composition and used most by the passengers. The entire definition process of standardized signage system shows systematism and integrality in signage design and planning research, and could be referred or used potentially in wider application of relevant studies.

Besides the concept of utility zone, another innovation of this study apart from previous signage evaluation research is that the proposed methodology can be readily implemented by the subway agencies. The evaluation approach is easy to understand and no specialized professional knowledge is required for the operators. The generated station floor plans with detailed signage deficiency and the summarized evaluation forms

can assist decision making authorities during signage improvement project. This study states fairly that practicability is always the primary consideration when theory is applied into real-world operations of subway stations.

5.3 Further Work

The original intention of this study is an attempt to consummate the methodology used in one case study of signage evaluation at Berri-UQAM station, and further establish an evaluation system for assessing signage performance that could be applied to a generic subway station in practice. Currently in this thesis the performance evaluation is demonstrated from three aspects. For each evaluation aspect affirmatively there could have further research work advanced in another step to optimize the existing evaluation framework.

For example, the proposed three-stage methodology to define a standardized signage system for one subway station, and the concept of utility zone, could also be applied into other types of transit stations or terminals (railway station or airport terminal). Also, in the evaluation of visibility optimization, the study only identifies the signs with affected visibility. However, related references or criteria are needed to clarify practical improvement measures on their poor-performed attributes. Moreover, it is unavoidable that subjective estimation could exist in the process of visibility checking, in terms of determining attribute performances. Usually a comprehensive consideration based on multiple checking results from more than one operator could ameliorate the potentially biased personal opinions.

REFEFENCES

1. Neurath, O., *International Picture Language: the First Rules of Isotype*. K. Paul, Trench, Trubner & co., ltd., London, 1936.
2. McLendon, C. B. and Blackistone, M., *Signage: Graphic Communications in the Built World*. McGraw-Hill, New York, 1982.
3. Uebele, A., *Signage Systems & Information Graphics: a professional sourcebook*. Thames & Hudson, London, 2007.
4. Garvey, P. M., Urban Wayfinding Signs: Evaluating Exceptions to FHWA's Standard Alphabets. In *Transportation Research Record: Journal of the Transportation Research Board*, No. 2030, Transportation Research Board of the National Academies, Washington, D.C., 2007, pp. 10–14.
5. Gibson, D., *The Wayfinding Handbook: Information Design for Public Places*. Princeton Architectural Press, New York, 2009.
6. Lascano, R., What Makes A Good Wayfinding System? *Arrows & Icons Magazine*, issue No. 003, 2009. <http://www.arrowsandicons.com/articles/what-makes-a-good-wayfinding-system/>. Accessed Jun. 7, 2010.
7. Passini, R., *Wayfinding in Architecture*. Van Nostrand Reinhold, New York, 1992.
8. Salmi, P., Wayfinding Design: Hidden Barriers to Universal Access. *Implications*, Vol. 05, Issue 08, 2007. http://www.informedesign.umn.edu/_news/aug_v05r-p.pdf. Accessed Jun. 16, 2010.
9. Arthur, P. and Passini, R., *Wayfinding: People, Signs, and Architecture*. McGraw-Hill, New York, 1992.
10. Levine, D. R., *Universal Design New York*. IDeA Publications, New York, 2001.

11. Osterberg, A. E. and Kain, D. J., *Access for Everyone: A Guide to the Accessibility of Buildings and Sites with References to ADAAG*. Iowa State University Facilities Planning & Management and Department of Architecture, College of Design, Ames, 2005.
12. Mencap's Accessibility Unit. *Report for Signage and Wayfinding for People with Learning Difficulties*. Product Code 06 BD 040030, Department for Communities and Local Government, London, 2006.
13. Sánchez, J. and Sáenz, M., Metro Navigation for the Blind. *Computers & Education*, 1-12, 2010.
14. Kong, J., Research of the Barrier-free Design on Interior Space Environment of Subway Station. *Interior Design*, Vol. 3, 2009, pp. 18-22.
15. *ADA Standards for Accessible Design*. 28 CFR Part 36, U.S. Department of Justice, 1994. <http://www.ada.gov/adastd94.pdf>. Accessed Jun. 4, 2010.
16. Zhang Y., Chen X. and Jiang J., Wayfinding-Oriented Design for Passenger Guidance Signs in Large-Scale Transit Center in China. In *Transportation Research Record: Journal of the Transportation Research Board*, No. 10-0173, Transportation Research Board of the National Academies, Washington, D.C., 2010, pp.
17. Duszek, R., The Warsaw Subway Signage System. *Information Design Journal*, 12:3, 2004, pp. 181-186.
18. Chen, Y. H. S., Wayfinding Recommendations for the Navigation of Taipei's Subway System through Improved Graphic Design and Sign Design. MS thesis. Iowa State University, 2006.

19. Dai, L., Nine Assistant Guiding Methods in Subway Design – A Research of Shanghai Subway Users. *Lecture Notes in Computer Science*, Vol. 5612, 2009, pp. 125-132.
20. Xu, X., Song, B., Li, C. and Hu, X., Study on the Safety and Disaster-Prevention Signing System of the Subway Based on Site Investigation at Home and Abroad. In *International Conference on Management and Service Science, MASS 2009*, No. 5302606, Sep., 2009.
21. Kong, J., Shu, Y., Ma, S. and Wu, M., Comprehensive Evaluation Research on Efficacy of Service Sign System of Subway Station. *Journal of Tongji University (Natural Science)*, Vol. 8, 2007, pp. 1064-1068.
22. Chen, Z., Chen, X. and Xiong, W., Evaluation of Guiding Sign Design Based on Isovist Superposition Analysis. *Urban Mass Transit*, Vol. 4, 2009, pp. 19-24.
23. Cao, D., Research of Sign-oriented Set Project and Evaluation of Passenger in Large-scale Integrated Transport Station. MS thesis. Beijing Jiaotong University, 2008.
24. Eiseman, L., *Color: Messages and Meanings: a Pantone Color Resource*. North Light Books, 2006.
25. Calori, C., *Signage and Wayfinding Design: A Complete Guide to Creating Environmental Graphic Design Systems*. John Wiley & Sons, New Jersey, 2007.
26. Carter, R., Day, B. and Meggs, P. B., *Typographic Design: Form and Communication*. John Wiley & Sons, New Jersey, 2006.
27. Apelt, R., Crawford, J. and Hogan, D., *Wayfinding Design Guidelines*. *Construction Innovation, Brisbane, 2007*.

28. Zhang, Y., Discussion on Direction Sign Design in Harmony with Environment. *Packaging Engineering*, Vol. 3, 2009, pp 201-203.
29. *London Underground Signs Manual, Issue 4*. Transport for London, Oct. 2002.
30. *Beijing Railway Technical Standard for Public Signs and Markings (Interim)*. Beijing Transport Commission, Dec. 2006.
31. *The Americans with Disabilities Act: White Paper*. SEGD, April 1993.
32. Q. Zeng, A. Alecsandru, T. K. C. Huang, B. Rouhieh, and A. R. Khan, Performance Evaluation of Subway Signage, Part I: Methodology. *Transportation Research Board 90th Annual Meeting*, Washington, D.C., 2011, Paper #11-0588.
33. Q. Zeng, A. Alecsandru, T. K. C. Huang, B. Rouhieh, and A. R. Khan, Performance Evaluation of Subway Signage, Part II: A Case Study. *Transportation Research Board 90th Annual Meeting*, Washington, D.C., 2011, Paper #11-0584.
34. Berri-UQAM (Montreal Metro). Wikipedia. [http://en.wikipedia.org/wiki/Berri-UQAM_\(Montreal_Metro\)](http://en.wikipedia.org/wiki/Berri-UQAM_(Montreal_Metro)). Accessed Jun. 9, 2010.

APPENDIX I

Legend

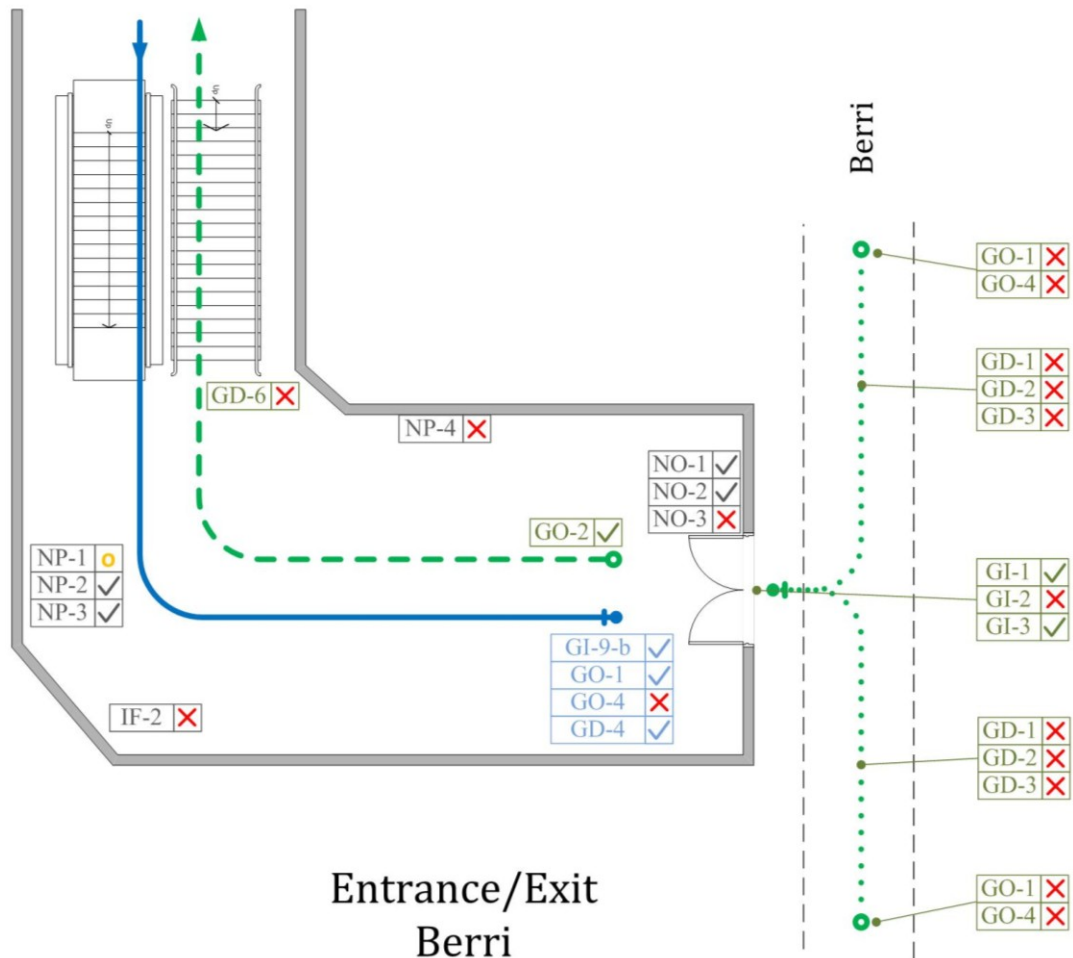
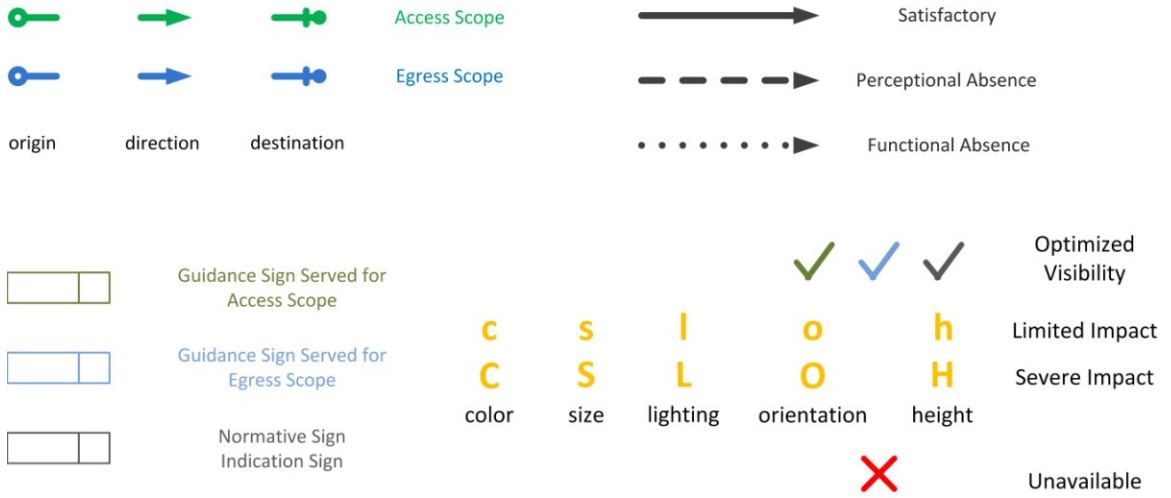

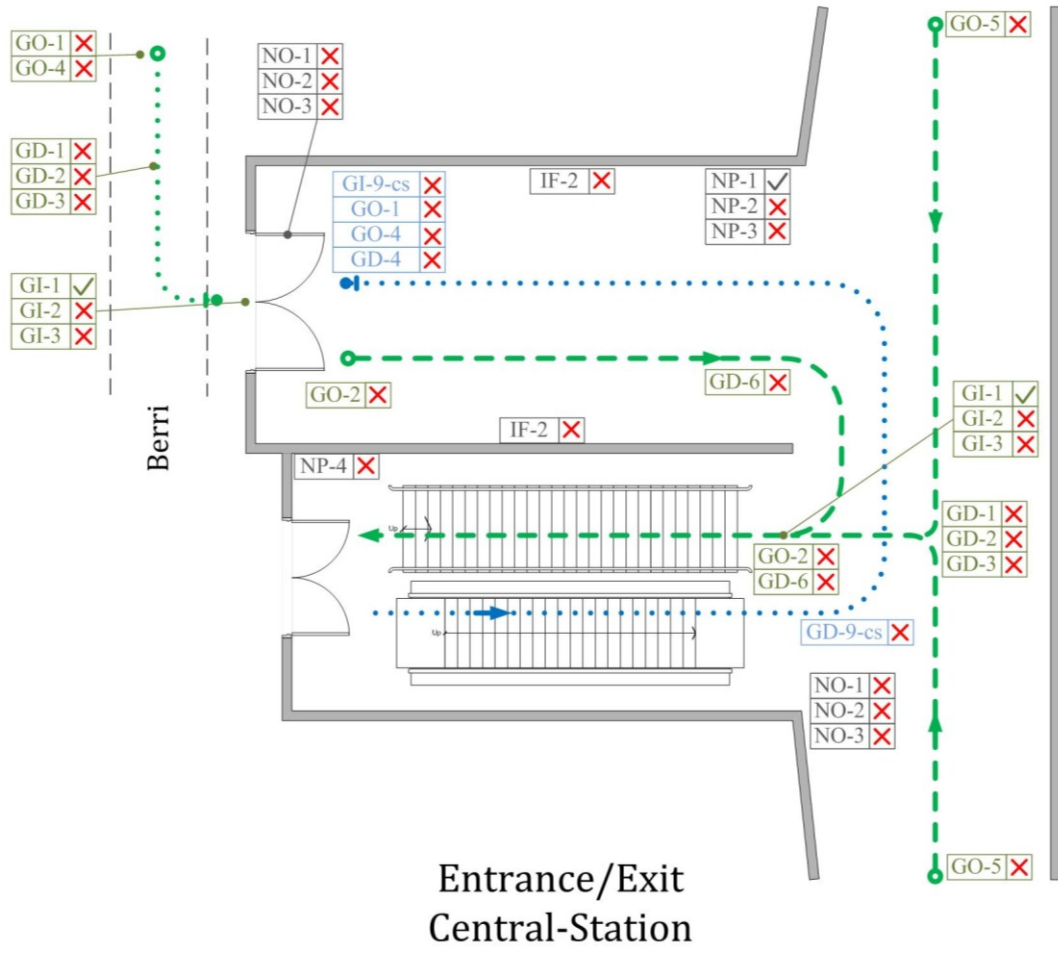

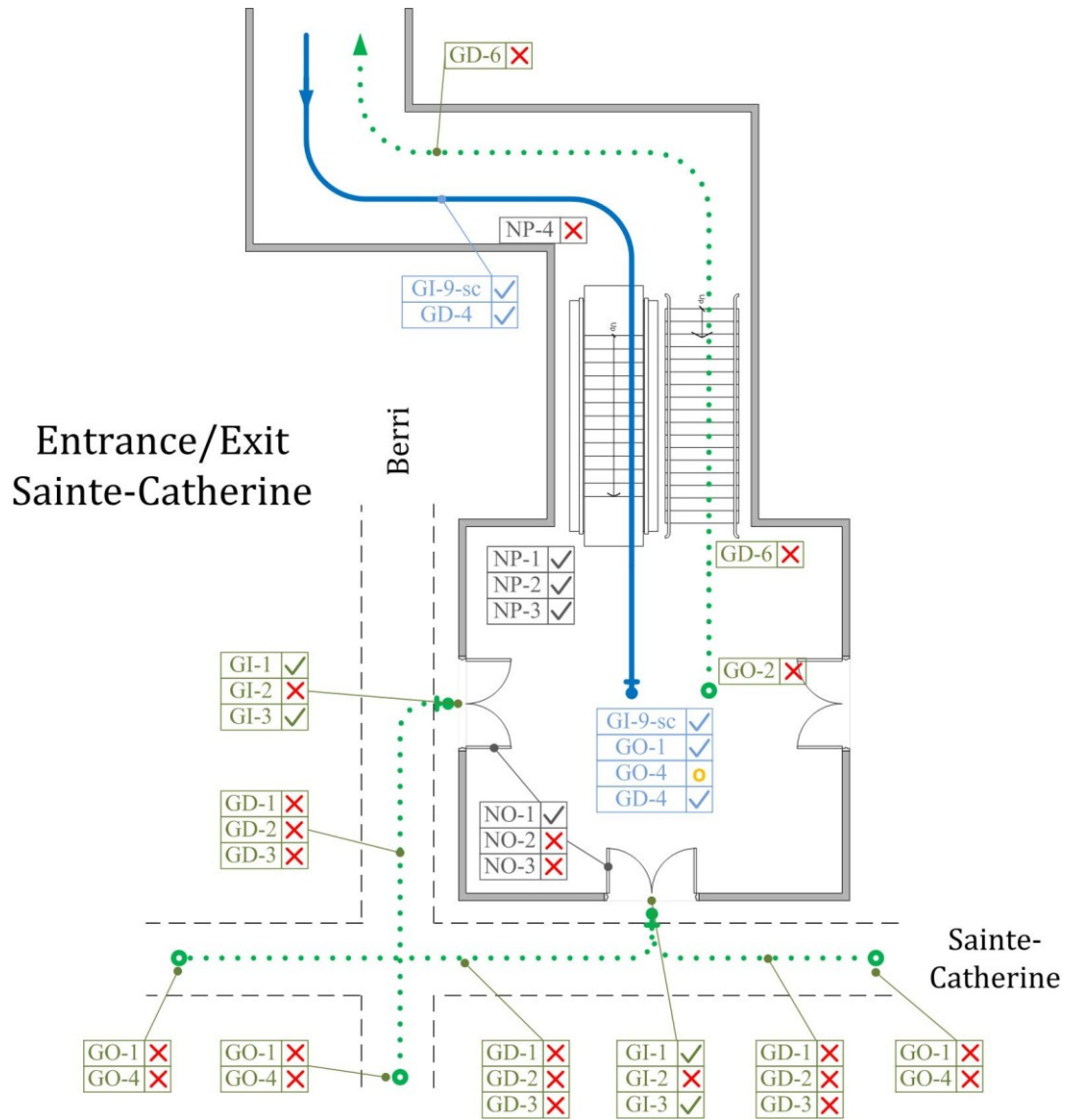

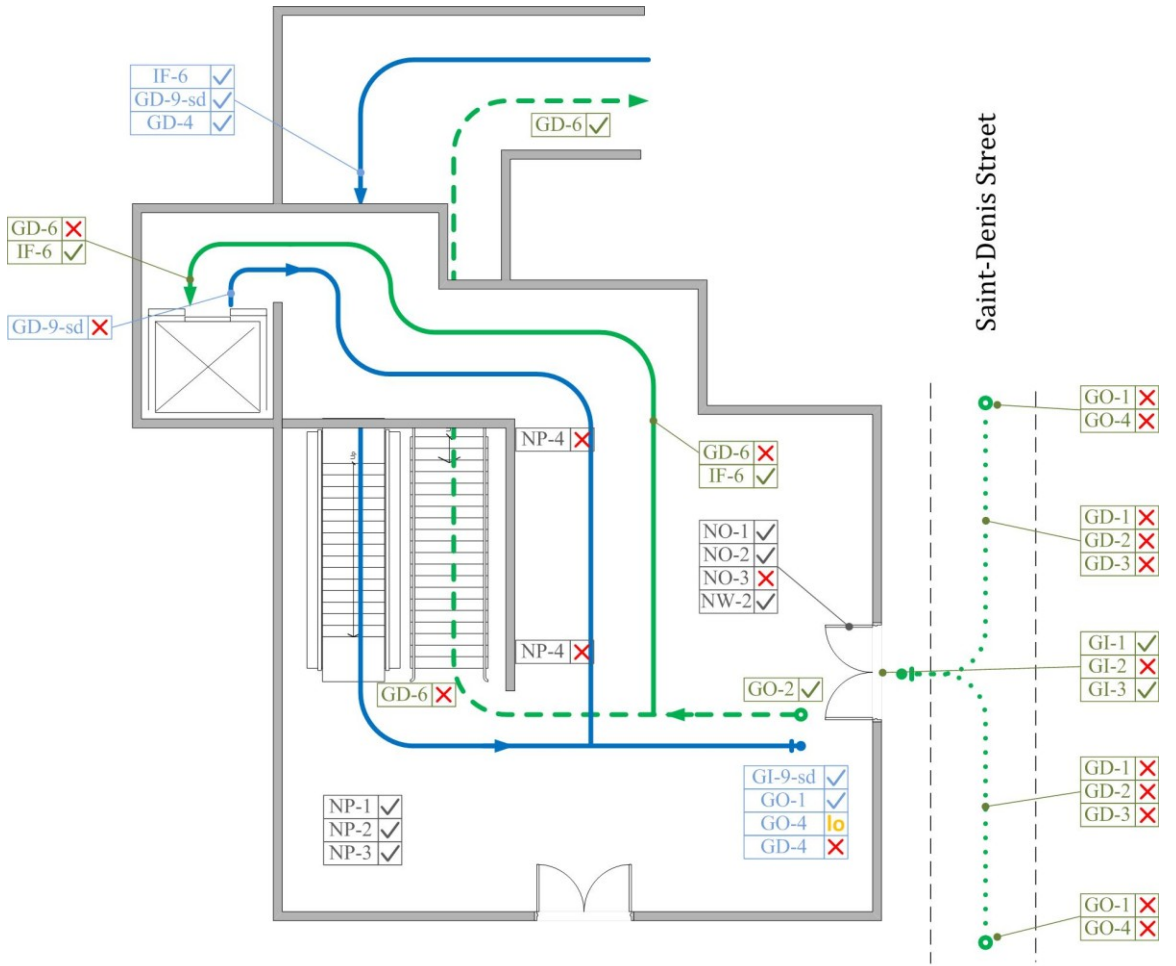

Entrance/Exit
Saint-Denis

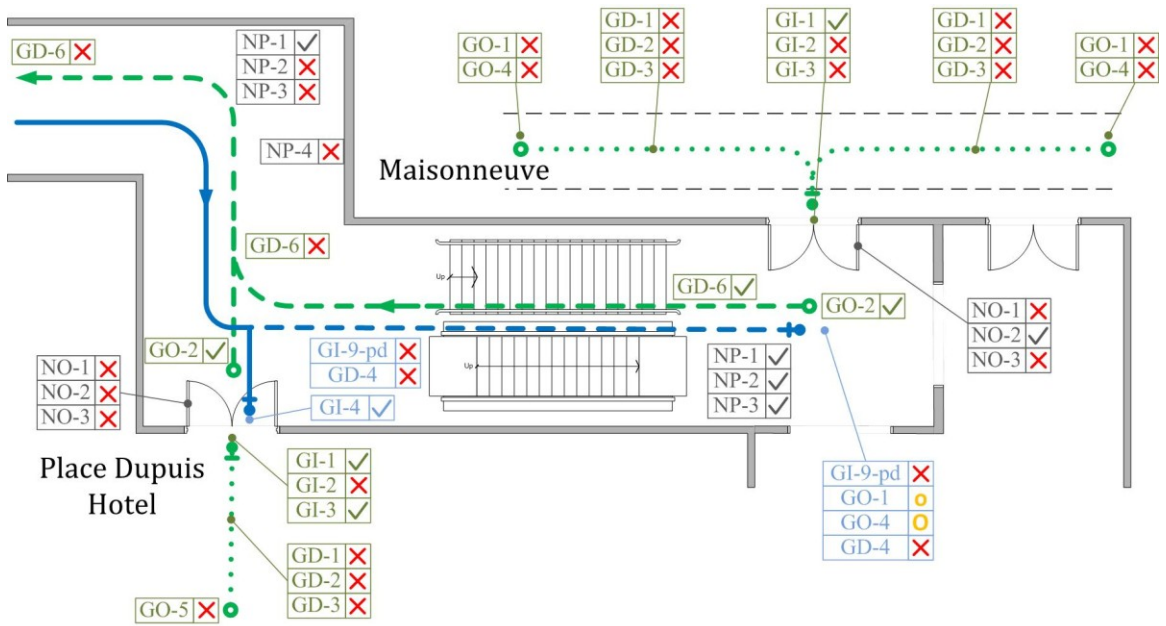

Entrance/Exit
Place-Dupuis

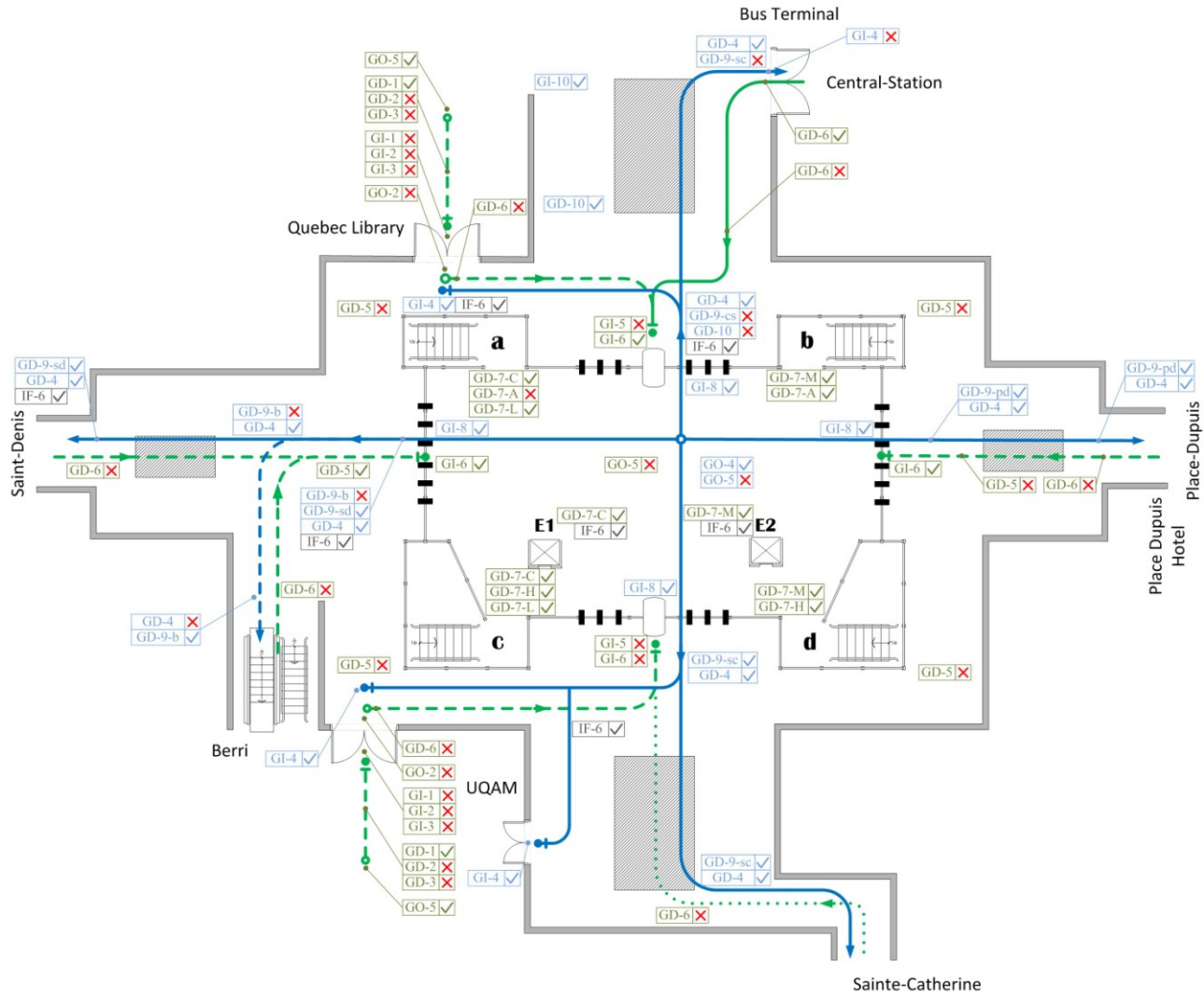

Hall

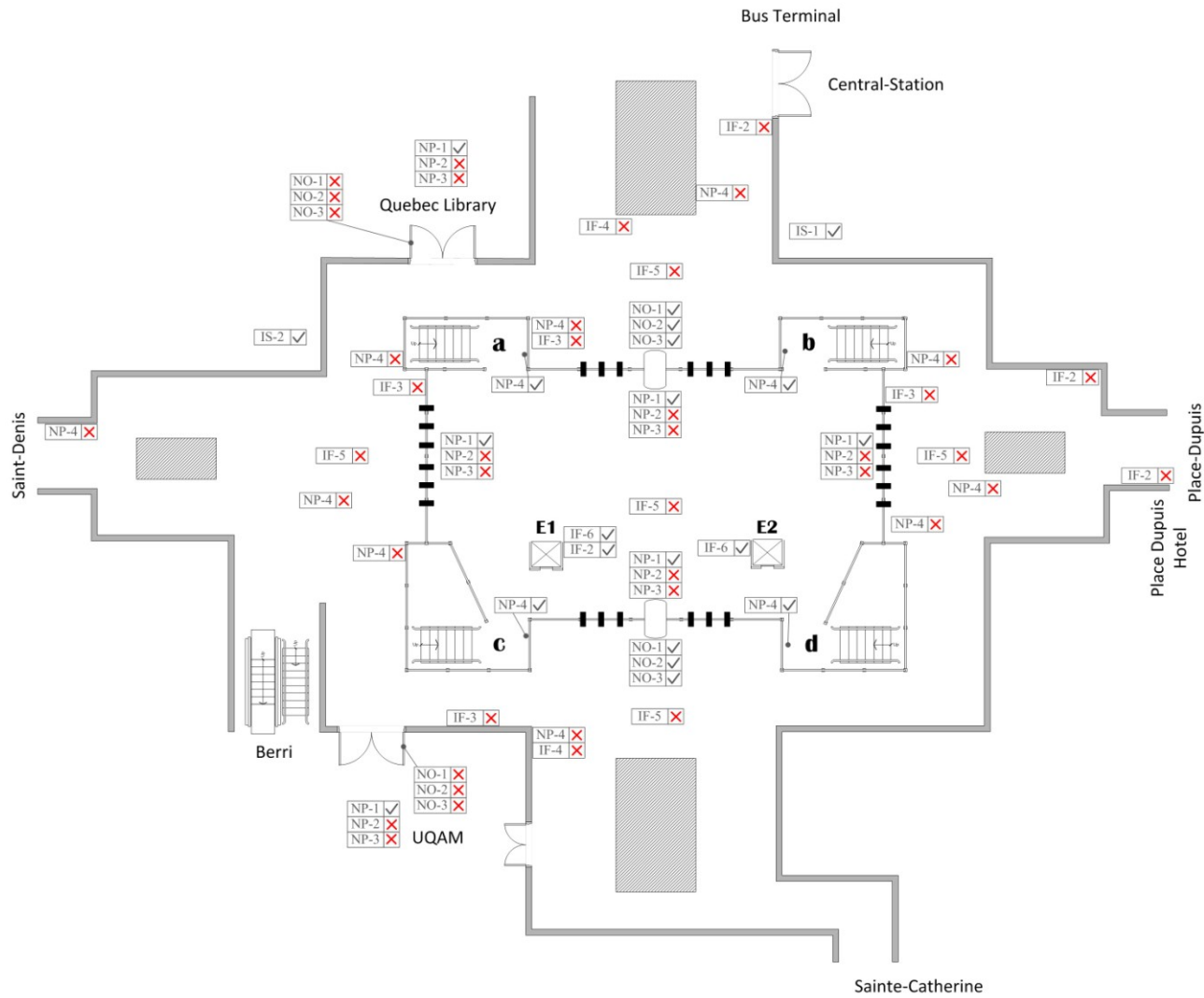

Hall

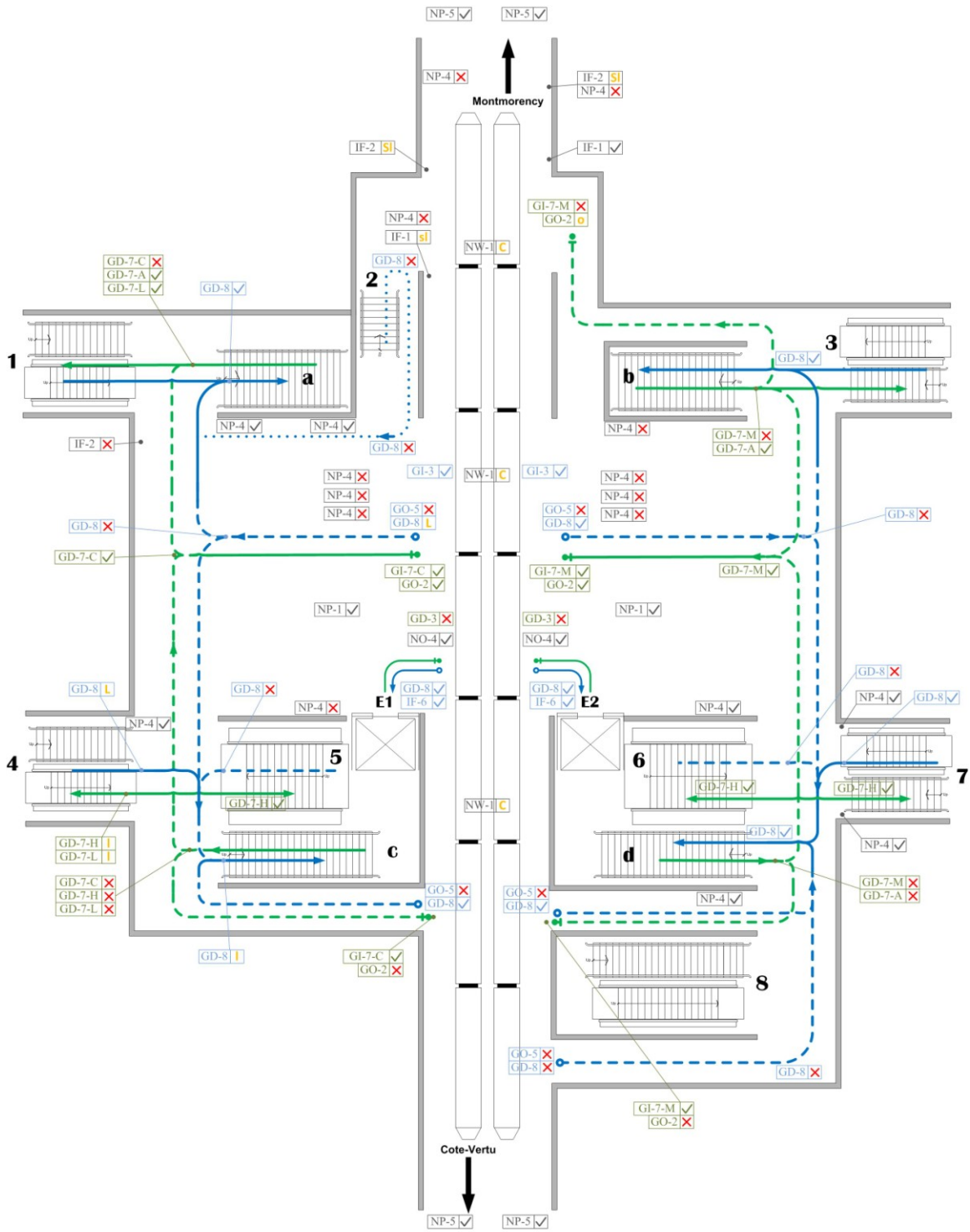

Orange Line

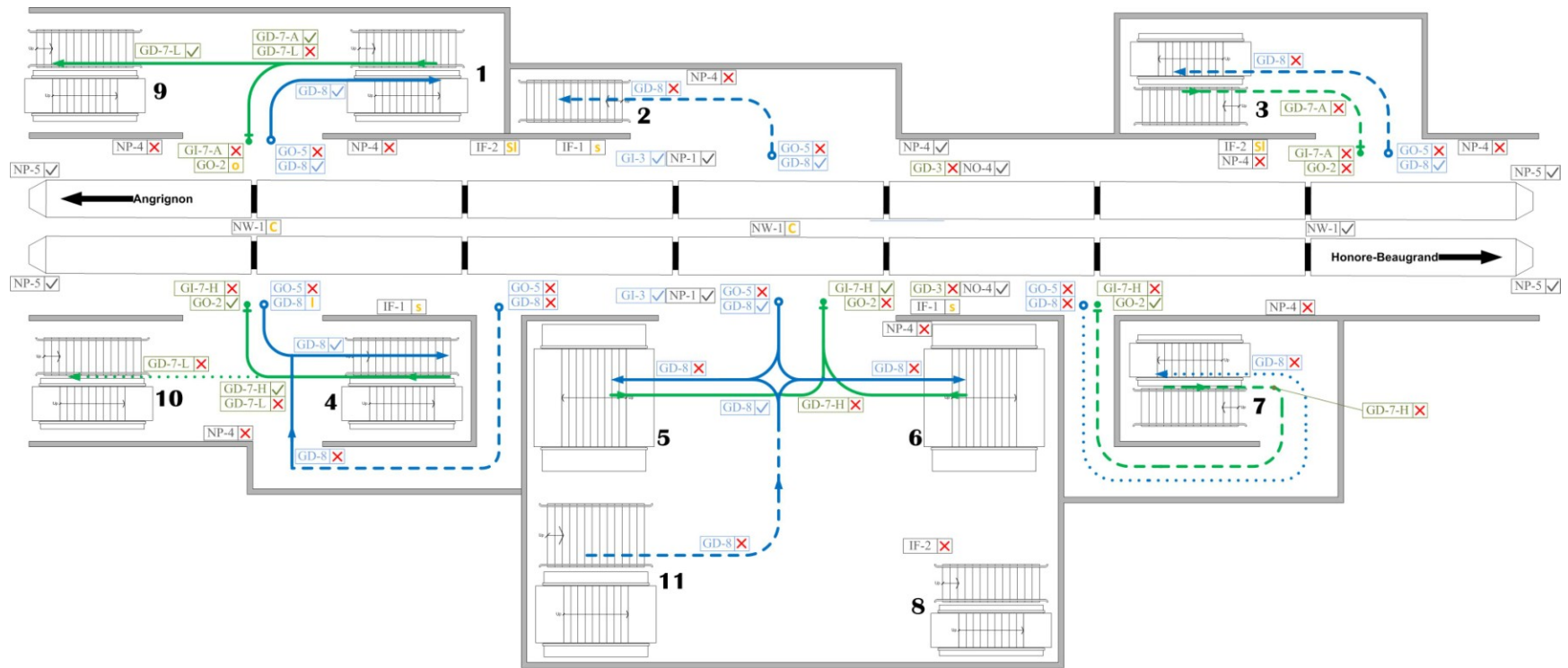

Green Line

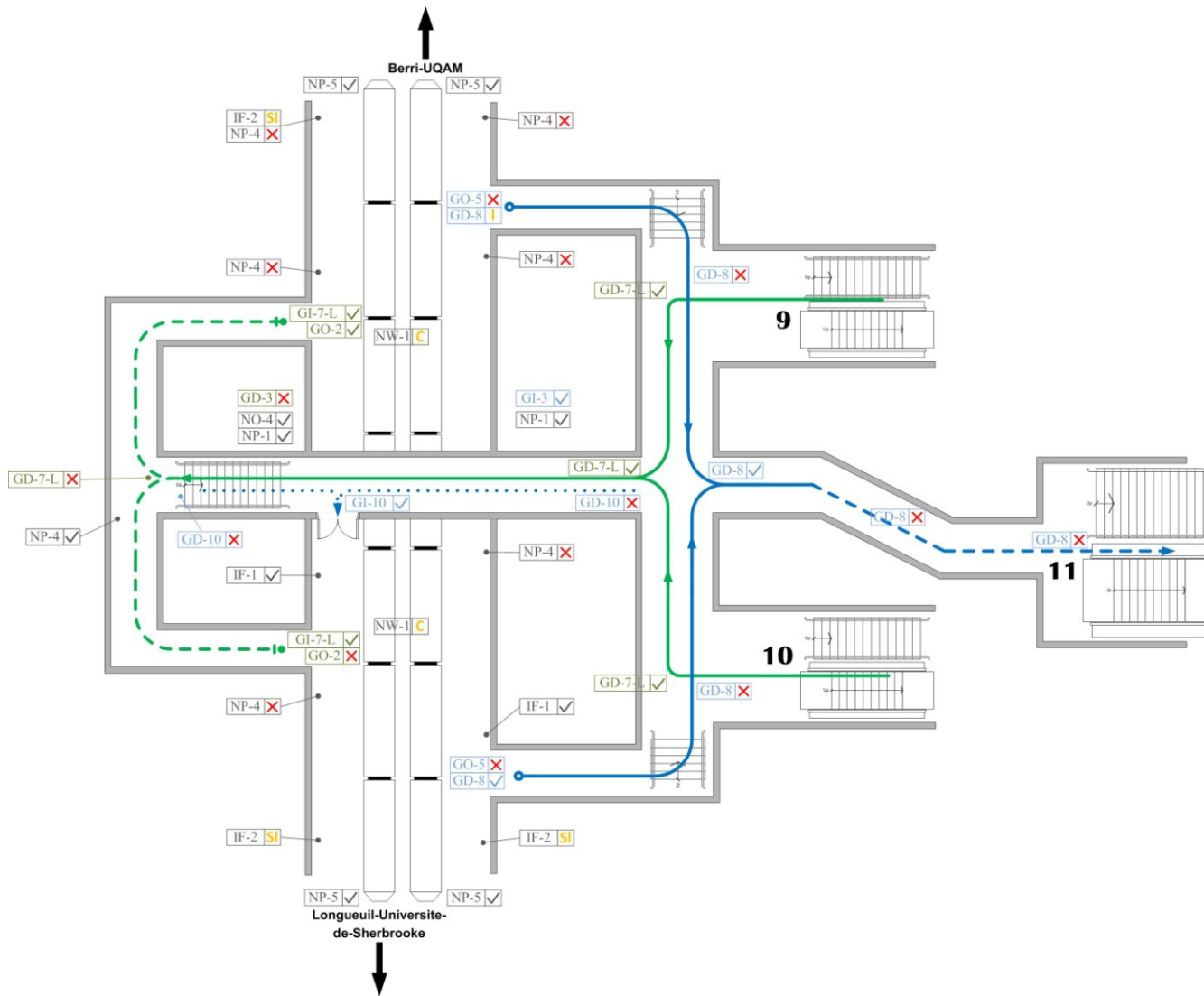

Yellow Line

Legend

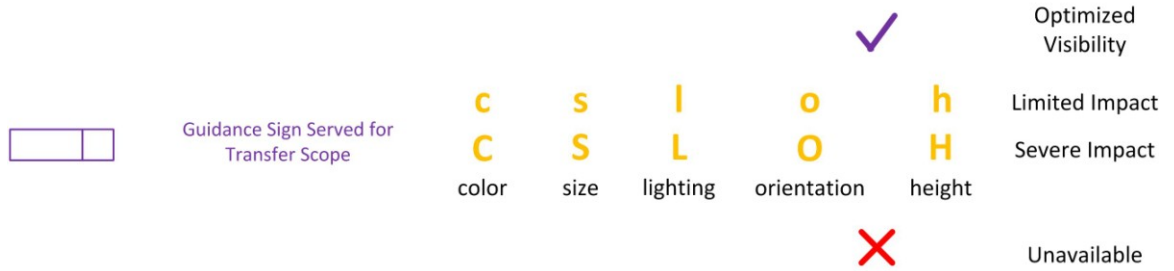

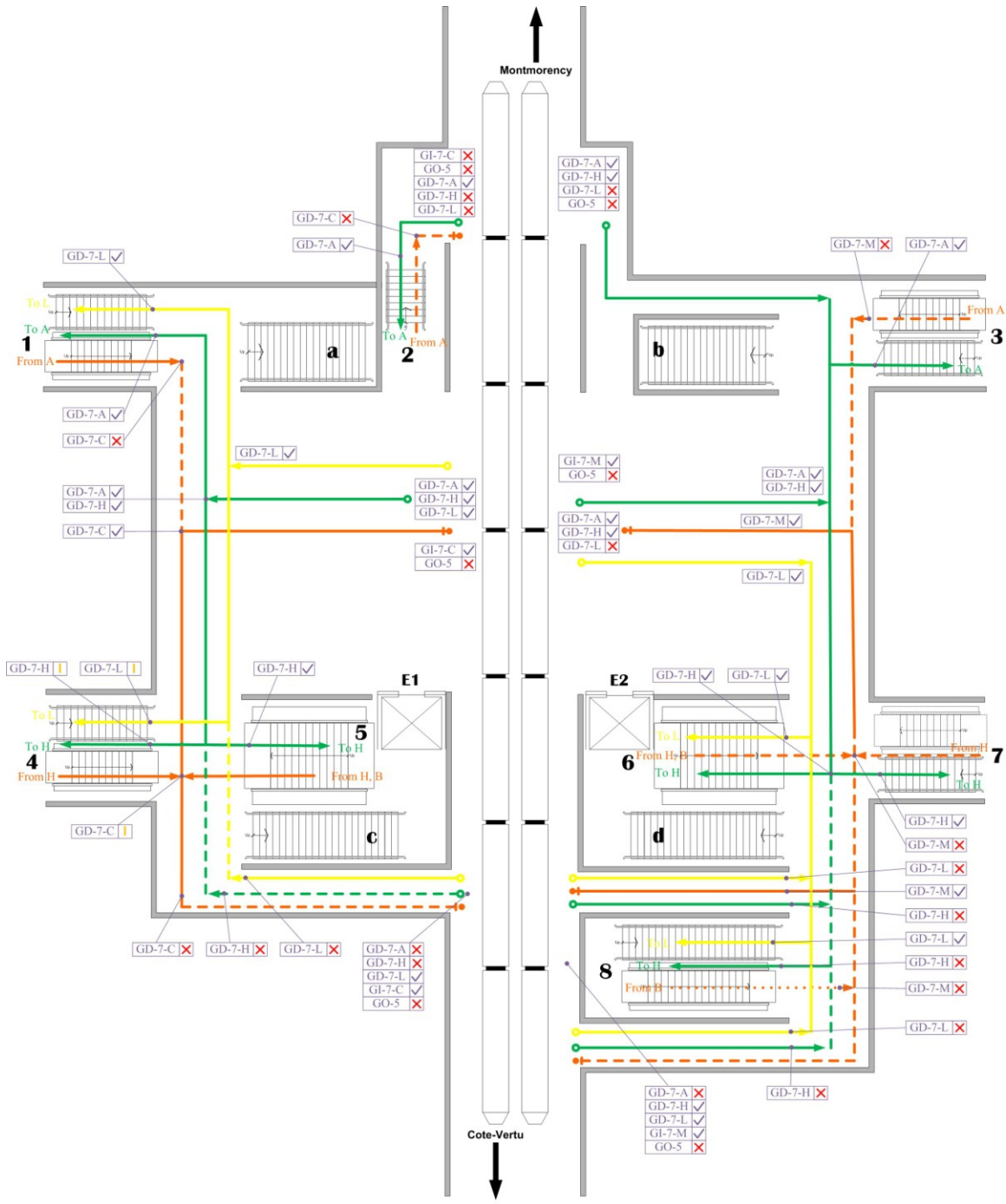

**Orange Line
(Transfer Scope)**

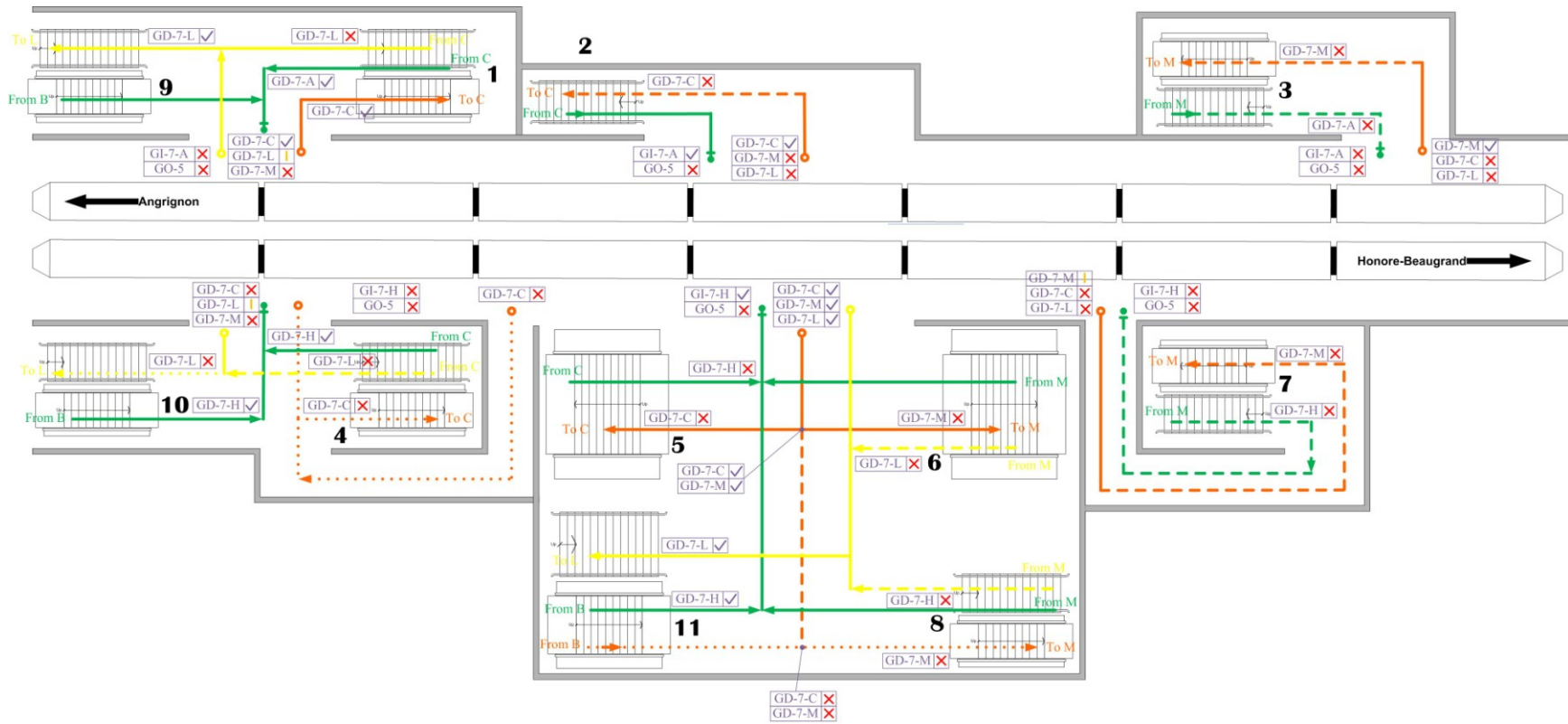

**Green Line
(Transfer Scope)**

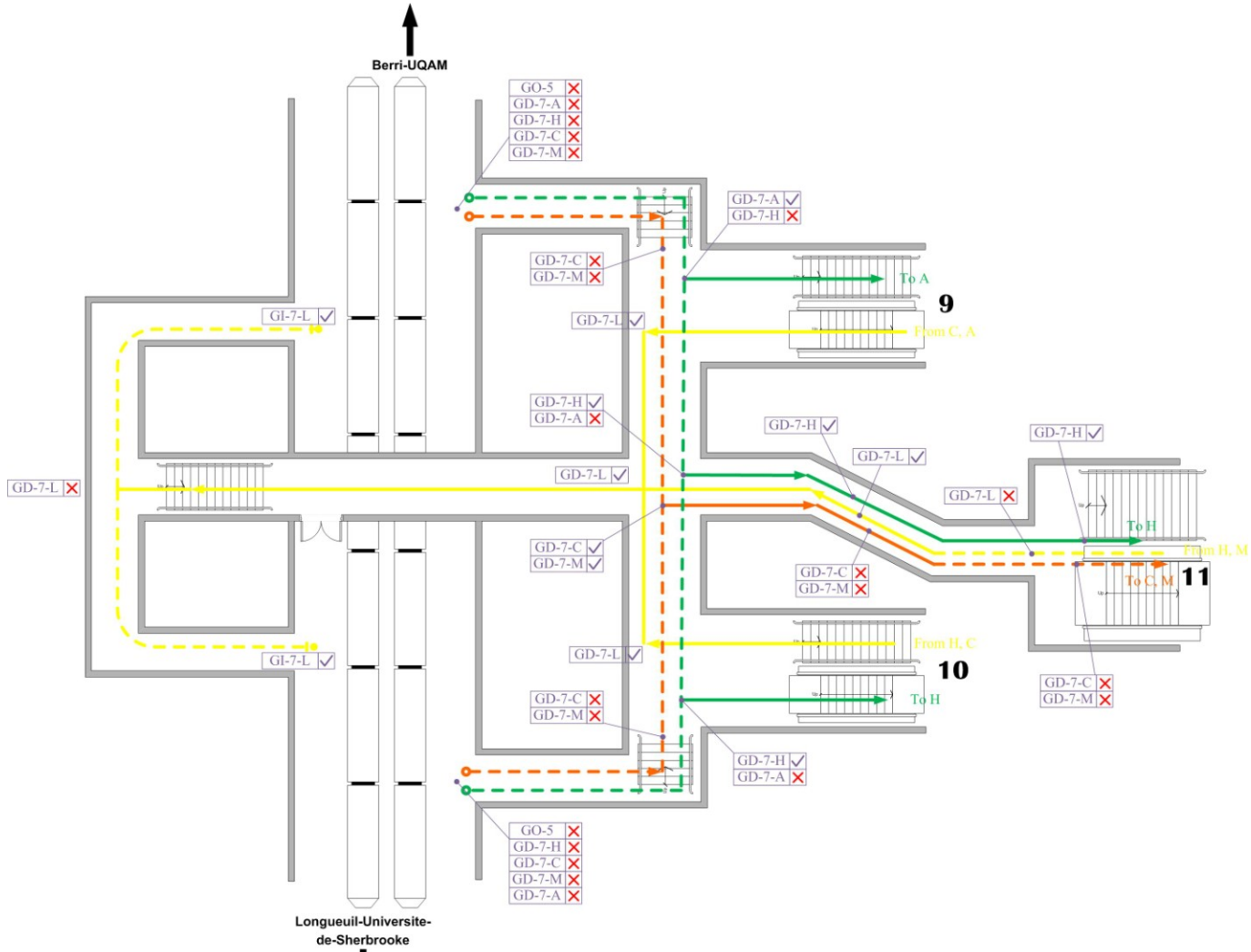

**Yellow Line
(Transfer Scope)**

APPENDIX II

Guidance Signs Evaluation

Project: Station Name:

Points of Interest		Evaluation	Station											
			Entrance/Exit	Evaluation		Hall	Evaluation		Platform	Montmorency	Côte-Vertu	Honoré-Beaugrand	Angrignon	Longueuil
		Access		Access	Egress		Access	Egress						
Street	Maisonneuve	F	Place-Dupuis	P	S	Ticket Service & Entry/Exit Gate	P	P	Montmorency	-	-	S	S	S
	Sainte-Catherine Berri	F	Sainte-Catherine	F	S		P	P	Côte-Vertu	-	-	S	S	P
	Saint-Denis	F	Siant-Denis	P	S		S	P	Honoré-Beaugrand	P	P	-	-	P
	Berri	F	Central-Station	P	F		P	P	Angrignon	P	P	-	-	S
		F	Berri	P	P		S	-	Longueuil	-	-	-	-	-
Underground Attractions	Place Dupuis Hotel	F	Joint Area (Access/Egress)	P	S	-	P	Berri-UQAM	P	P	S	S	-	
	UQAM	P		P	S									
	Quebec Libriry	P		P	S									
	Bus Terminal	P		S	S									
Remarks		1. Signage types of GD-1, GD-2 and GD-3 are not available at street level; 2. Signage types of GD-3 and GO-5 are not available at platform level; 3. Signage number of GD-10 is not enough at neither hall nor yellow line; 4. Passenger's current position should be indicated on orientation signs (GO-4, GO-5).												

Legend: S: Satisfactory P: Perceptual Absence F: Functional Absence -: not applicable

Evaluation Date:

Prepared By:

Inventory of Normative and Indication Signs

Project: Station Name:

Signs at Entrance/Exit

Subcategory	Sign Information	Entrance/Exit									Total Number	Remarks
		Ground					Underground					
		Berri	Central-Station	Ste-Catherine	St-Denis	Place-Dupuis	Bus Terminal	PlaceDupuis Hotel	Quebec Library	UQAM		
Operation Information [NO]	NO-1 Bicycle Regulation	√	1	√	√	1	1	1	1	1	6	No available normative signs at underground entrance/exits. Sign NO-3 is seriously absent.
	NO-2 Operation Time	√	1	1	√	√	1	1	1	1	6	
	NO-3 Fares Information	1	1	2	1	1	1	1	1	1	10	
Warning Signs [NW]	NW-3 Attention Autodoor	-	-	-	√	-	-	-	-	-	-	
Prohibition Signs [NP]	NP-1 No Smoking	1	√	√	√	√	1	√	1	1	4	NP-1, 2, 3 sign should be presented to passenger once they enter into the station zone.
	NP-2 No Roller Skating	√	1	√	√	√	1	1	1	1	5	
	NP-3 No Skateboard	√	1	√	√	√	1	1	1	1	5	
	NP-4 No Newspaper in Garbage Bin	1	-	1	2	1	1	-	-	-	6	
Facility Indication [IF]	IF-2 Public Phone	1	2	-	-	-	-	-	-	-	3	
	IF-8 Elevator	-	-	-	√	-	-	-	-	-	-	

Legend: √: Good Condition 1: Number of Absent Signs and Signs with Affected Visibility -: not applicable

Evaluation Date:

Prepared By:

Inventory of Normative and Indication Signs

Project: Station Name:

Signs at Platforms

Subcategory	Sign Information	Platform						Total Number	Remarks
		M	C	H	A	L	B		
Operation Information [NO]	NO-4 Next Arrival Time	√	√	√	√	√	-	-	
Warning Signs [NW]	NW-1 Danger-High Voltage	3	3	2	2	2	-	12	NW-1 is too blur to be seen.
Prohibition Signs [NP]	NP-1 No Smoking	√	√	√	√	√	√	-	
	NP-4 No Newspaper in Garbage Bin	5	6	3	5	3	3	25	
	NP-5 No Entry	√	√	√	√	√	√	-	
Facility Indication [IF]	IF-1 SOS Assistance	√	1	2	1	√	√	4	
	IF-2 Public Phone	1	2	1	2	2	1	9	IF-2 can hardly be seen along platform.
	IF-6 Elevator	√	√	-	-	-	-	-	

Legend: M: Montmorency C: Côte-Vertu H: Honoré-Beaugrand A: Angrignon L: Longueuil B: Berri-UQAM
 √: Good Condition 1: Number of Absent Signs and Signs with Affected Visibility -: not applicable

Evaluation Date:

Prepared By:

Inventory of Normative and Indication Signs

Project: Station Name:

Signs at Hall Level

Subcategory	Sign Information	Hall	Remarks
Operation Information [NO]	NO-1 Bicycle Regulation	✓	
	NO-2 Operation Time	✓	
	NO-3 Fares Information	✓	
Prohibition Signs [NP]	NP-1 No Smoking	✓	NP-1,2,3 should assemble together as a signage combination.
	NP-2 No Roller Skating	4	
	NP-3 No Skateboard	4	
	NP-4 No Newspaper in Garbage Bin	10	
Service Indication [IS]	IS-1 STM Customer Service	✓	
	IS-2 STM Security	✓	
Facility Indication [IF]	IF-1 SOS Assistance	✓	Information board should be indicated by the sign IF-5 for visibility. IF-2 is too small.
	IF-2 Public Phone	3	
	IF-3 Ticket Machine	4	
	IF-4 ATM Machine	2	
	IF-5 Information Board	5	
	IF-6 Elevator	✓	

Legend:

✓: Good Condition 1: Number of Absent Signs and Signs with Affected Visibility -: not applicable

Evaluation Date:

Prepared By: