

INFORMATION TO USERS

This manuscript has been reproduced from the microfilm master. UMI films the text directly from the original or copy submitted. Thus, some thesis and dissertation copies are in typewriter face, while others may be from any type of computer printer.

The quality of this reproduction is dependent upon the quality of the copy submitted. Broken or indistinct print, colored or poor quality illustrations and photographs, print bleedthrough, substandard margins, and improper alignment can adversely affect reproduction.

In the unlikely event that the author did not send UMI a complete manuscript and there are missing pages, these will be noted. Also, if unauthorized copyright material had to be removed, a note will indicate the deletion.

Oversize materials (e.g., maps, drawings, charts) are reproduced by sectioning the original, beginning at the upper left-hand corner and continuing from left to right in equal sections with small overlaps.

ProQuest Information and Learning
300 North Zeeb Road, Ann Arbor, MI 48106-1346 USA
800-521-0600

UMI[®]

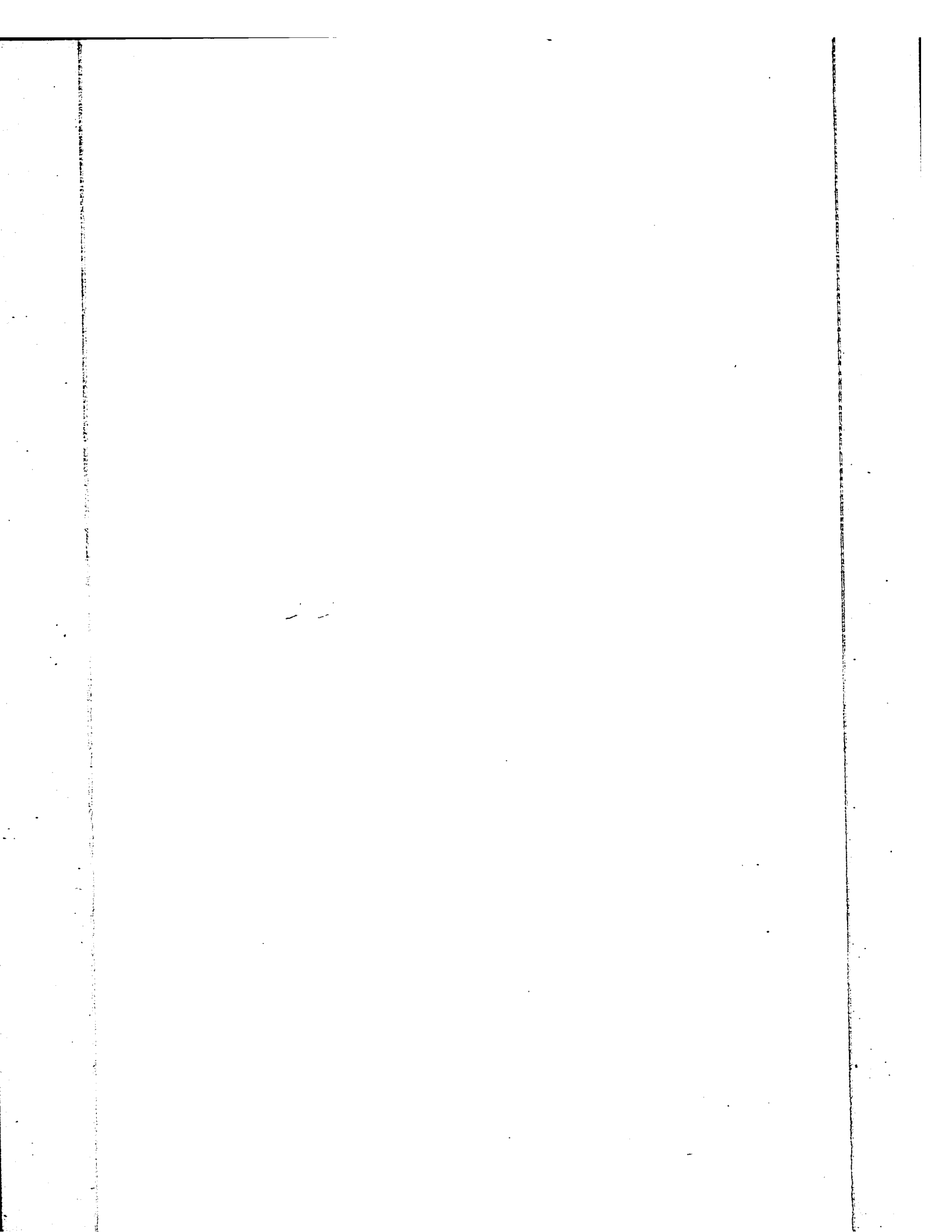

NOTE TO USERS

This reproduction is the best copy available.

UMI[®]

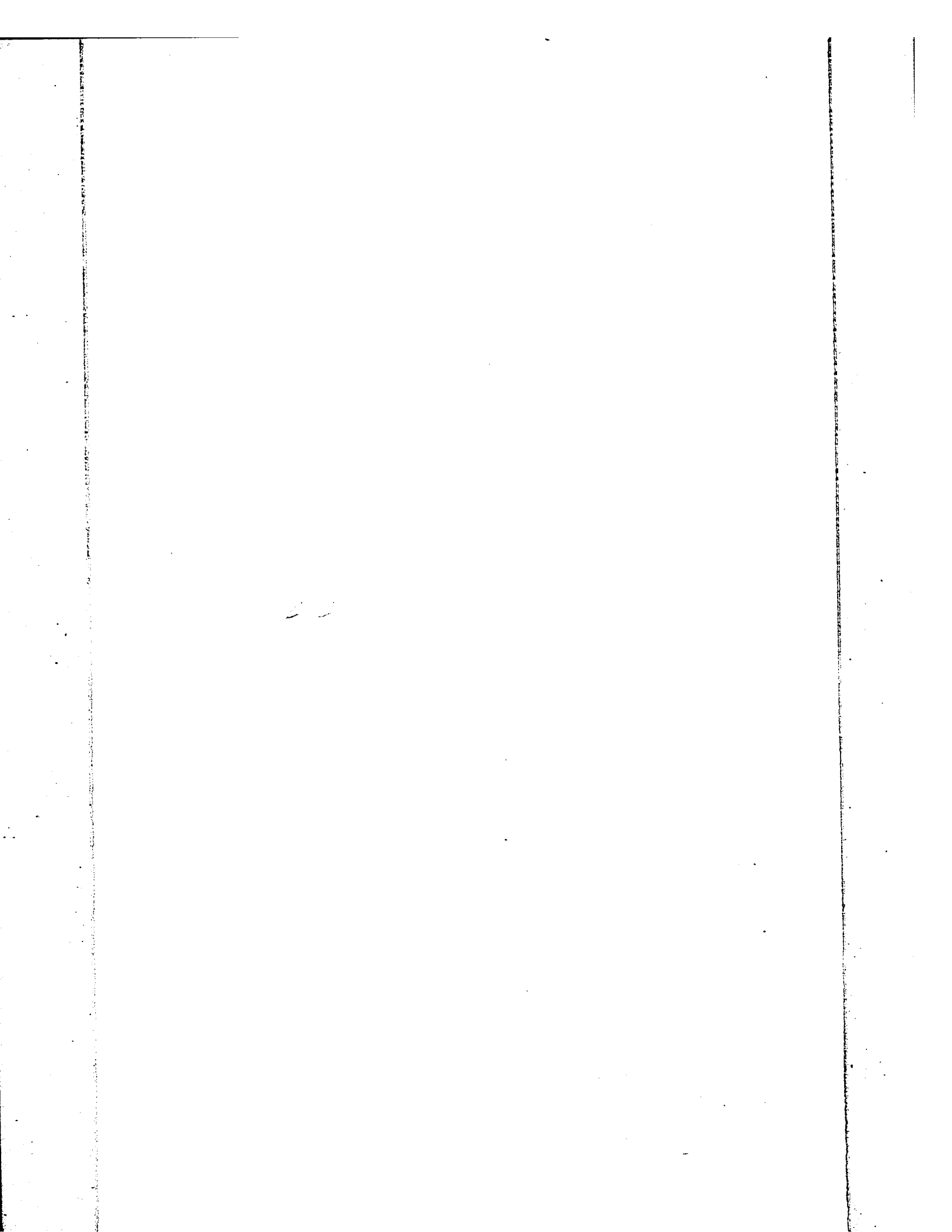

Admission Control and Congestion Control in ATM/CDMA Network

QingZhong Jiao

A Thesis

in

The Department

of

Electrical and Computer Engineering

Presented in Partial Fulfillment of the Requirements

for the Degree of Master of Applied Science at

Concordia University

Montréal, Québec, Canada

March 1995

© QingZhong Jiao, 1995



National Library
of Canada

Bibliothèque nationale
du Canada

Acquisitions and
Bibliographic Services

Acquisitions et
services bibliographiques

395 Wellington Street
Ottawa ON K1A 0N4
Canada

395, rue Wellington
Ottawa ON K1A 0N4
Canada

Your file *Votre référence*

Our file *Notre référence*

The author has granted a non-exclusive licence allowing the National Library of Canada to reproduce, loan, distribute or sell copies of this thesis in microform, paper or electronic formats.

L'auteur a accordé une licence non exclusive permettant à la Bibliothèque nationale du Canada de reproduire, prêter, distribuer ou vendre des copies de cette thèse sous la forme de microfiche/film, de reproduction sur papier ou sur format électronique.

The author retains ownership of the copyright in this thesis. Neither the thesis nor substantial extracts from it may be printed or otherwise reproduced without the author's permission.

L'auteur conserve la propriété du droit d'auteur qui protège cette thèse. Ni la thèse ni des extraits substantiels de celle-ci ne doivent être imprimés ou autrement reproduits sans son autorisation.

In compliance with the Canadian Privacy Act some supporting forms may have been removed from this dissertation.

Conformément à la loi canadienne sur la protection de la vie privée, quelques formulaires secondaires ont été enlevés de ce manuscrit.

While these forms may be included in the document page count, their removal does not represent any loss of content from the dissertation.

Bien que ces formulaires aient inclus dans la pagination, il n'y aura aucun contenu manquant.

MQ-90887

Canada

ABSTRACT

Admission Control and Congestion Control in ATM/CDMA Network

QingZhong Jiao

For CDMA to be a variable multiaccess approach to integrate multimediuim services over a wide range of constant and variable bit rate server, it is important to come out with suitable admission and congestion control techniques. This is because in CDMA systems the user's transmission overlap and large bit error probabilities would result that users violate their average bit rate agreements with satellite. Our work try to minimize the number of ATM/CDMA call overlap by proper traffic shaping function.

In this work, we show by computer simulation ways of alleviating congestion in ATM/CDMA broadband integrated satellite systems. A hybrid CDMA/TDMA/ATM approach is taken where a mixture of user classes namely video, voice, file and interactive data share a TDMA frame compared of four subframes where an ATM/CDMA technique is used by users of each class to access the time slots within their subframe. An M-array orthogonal sequence CDMA modulation is adopted and multipath fading satellite environment is assumed. Users are assumed to have the ATM/CDMA/TDMA interface and to commemorate their signals directly to the satellite in a hubless fashion.

Traffic shaping is something that happens in the customer premise equipment. If the Policing function is the policeman, and the charging function is the judge, then the traffic shaping function is the lawyer. The traffic shaping function uses information about the policing and charging functions in order to change the traffic characteristics of the customer's stream to get the lowest charge or the smallest cell-loss, etc. In this work, we simulated the policing function and traffic shaping function which the leaky bucket scheme is investigated.

ACKNOWLEDGEMENTS

The author wishes to express his deep gratitude to his supervisor, Dr. A.K.Elhakeem for his invaluable assistance, guidance and inspiration throughout the span of this research and for his advise during the preparation of the thesis.

This work was supported by SPARC and CRD which is gratefully acnowledged, especially the help of Dr. Le Ngoc.

Contents

1	Introduction to CDMA	8
1.1	Multiple Access Communication Protocols	9
1.2	Performance Evaluation and Classification	10
1.3	Code Division Multiple Access	13
1.3.1	The Basic Principles of CDMA	14
1.3.2	CDMA system design issue	16
1.3.3	The Applications of CDMA	17
1.3.4	CDMA satellite systems	19
1.3.5	Cellular CDMA	21
2	Introduction to ATM	29
2.1	Asynchronous Transfer Mode (ATM)	30
2.2	Standardization of ATM	32
2.2.1	ATM cell	32
2.2.2	ATM Network Layer Structure	35
2.3	ATM transmission Structure	36
2.3.1	ATDM	38
2.3.2	SONET	39
2.4	Congestion Control in ATM Networks	42

2.4.1	Objectives of ATM Congestion Control	43
2.4.2	Congestion Control Schemes for ATM network	44
3	Call Acceptance and Traffic Policing in ATM/CDMA	52
3.1	The Characteristics of Combined ATM and CDMA	53
3.1.1	ATM characteristics	54
3.1.2	CDMA characteristics	55
3.2	The Hybrid CDMA/ATM System Description	56
3.3	Simulation of Admission Rule and Cell Policing	57
3.3.1	The VBR-CDMA System	57
3.3.2	Modulation Aspects of the simulations	61
3.3.3	ATM/CDMA Call Admission and Traffic Policing	64
3.3.4	Simulation Results	77
4	Traffic Shaping in Hybrid ATM/CDMA/TDMA system	94
4.1	Introduction	95
4.2	System Description	96
4.2.1	Channel Model	101
4.2.2	Traffic Model	105
4.3	Congestion Control Schemes LB/VLB	109
4.4	Description of The Simulation	111
4.4.1	The CDMA/TDMA System parameters	112
4.4.2	The Traffic Source Parameters	116
4.4.3	The Congestion Control Parameters	118
4.4.4	The flow Control Parameters	122
4.5	Simulation Flow Charts	125
4.6	Simulation Results	133

5	The Conclusions	152
5.1	The Goal of The Thesis	152
5.2	The Beneficiaries of CDMA	153
5.3	CDMA with ATM	155
5.4	Traffic Policing	156
5.5	Traffic Shaping	157
5.6	Further Work	158

List of Figures

1.1	the classification of MAC	13
1.2	a model of CDMA system	14
1.3	illustration of different multiple access system	22
2.1	STM and ATM multiplexing	31
2.2	ATM cell structure	33
2.3	BISDN ATM protocol mode	35
2.4	a conceptual structure of the BISDN	37
2.5	the ATDM concept	38
2.6	the ATDM structure	39
2.7	STS-1 frame structure	39
2.8	the concepts of section, line and path	40
2.9	STS-N frame structure	41
2.10	ATM within SONET	42
2.11	a queueing model for a leaky bucket method	48
3.1	the system architecture	56
3.2	Direct sequence system with binary phase modulation	58
3.3	Transmission Diagram without policing	59
3.4	Transmission Diagram with cell policing	60

3.5	The state diagram of call acceptance	71
3.6	The flow chart of call admission control	72
3.7	Cell generation process of a bursty source	73
3.8	cell policing state diagram	76
3.9	the flow chart of the cell poling at the user premisses	76
3.10	The probability of call blocking vs ρ	79
3.11	The total throughput vs. ρ	80
3.12	Bit error probability vs. ρ	81
3.13	the congestion in CDMA system	82
3.14	the probability of congestion duration at $\rho = 0.2$ no policing	83
3.15	the probability of congestion duration at $\rho = 0.5$ no policing	84
3.16	the probability of congestion duration at $\rho = 0.8$ no policing	85
3.17	the probability of congestion duration at $\rho = 0.2$ with policing	86
3.18	the probability of congestion duration at $\rho = 0.5$ with policing	87
3.19	the probability of congestion duration at $\rho = 0.8$ with policing	88
3.20	the total throughput vs. ρ	89
3.21	the probability of discarding vs. ρ	90
3.22	the bit error probability vs. ρ	91
4.1	A DSSS-CDMA transmitter system with M -orthogonal codes	99
4.2	A RAKE receiver.	100
4.3	a mobile satellite system configuration	101
4.4	distribution of scatters in mobile radio environment	102
4.5	The block diagram of the channel model.	103
4.6	the error probability vs number of users	104
4.7	Three levels of ATM traffic	106
4.8	The two state VBR sources Model	107

4.9	the block diagram of leaky bucket	109
4.10	the block diagram of virtual leaky bucket	110
4.11	the leaky bucket as a filter	111
4.12	the simulation model of the CDMA/TDMA networks	112
4.13	the hybrid CDMA/TDMA frame structure	114
4.14	the window structure of the simulations	119
4.15	the buffer's update mechanism	121
4.16	the flow control n ATM/CDMA system	123
4.17	the flow control mechanism	124
4.18	the main flow chart of the simulation	125
4.19	the flow chart of system services	126
4.20	the window reset and the congestion detection mechanism	127
4.21	the cell policing mechanism for LB	128
4.22	the cell policing for VLB	129
4.23	the burst checking mechanism	130
4.24	the TDMA superframe assignments	131
4.25	the CDMA service channel	132
4.26	the video user's delay	133
4.27	the voice user's delay	134
4.28	the file user's delay	135
4.29	the data stream user's delay	136
4.30	the video user's discard	137
4.31	the voice user's discard	138
4.32	the file user's discard	139
4.33	the data stream user's discard	140
4.34	the data stream user's discard	141
4.35	the video user's successful sending probability	142

4.36 the voice user's successful sending probability	143
4.37 the file user's successful sending probability	144
4.38 the data stream user's successful sending probability	145
4.39 the system bandwidth efficiency compared LB/VLB	146
4.40 the system bandwidth efficiency compared two cases	147
4.41 the video users' system delay compared 3 cases	148

Chapter 1

Introduction to CDMA

Spread spectrum communication systems have the characteristic attributes that the required transmission bandwidth is greater than the baseband message signal bandwidth and that the transmission bandwidth is determined by a spreading signal that is independent of the message. Furthermore, the receiver recovers the message by using a replica of the spreading signal. Spread spectrum systems as just defined do not include some familiar communication techniques such as wideband FM and PCM that occupy a relatively large transmission bandwidth, since the transmission bandwidth is a function of the message signal for these systems.

Direct Sequence Code Division Multiple Access networks have gained momentum recently[1] due to such characteristics as multipath fading resistance, some inherent security, low power cost per station, inherent voice silence utilization, automatic cellular frequency reuse[2], etc. CDMA networks are potential candidates for indoor communications, personal and consumer communications[2], factory automation, cellular communications, satellite communications, cordless LAN, etc.

1.1 Multiple Access Communication Protocols

A multiple access communication protocol is a set of rules to control access to a shared communication channel capacity among the various contending users. Access protocols use different multiple access media. Examples of such multiple access media are satellite, radio networks and optical fiber wires used in local area networks or in metropolitan area networks.

In relation to OSI model (open system interconnection), the data link layer of the network is divided into the MAC (medium access control) lower layer and LLC (logical link control) upper layer. Here we discuss some of the protocol standards regarding the MAC sublayer and LLC sublayer.

It is important to distinguish between multiplexing and multiple access, both refer to sharing of a communication resource, however, there is a difference. With multiplexing, the system controller has instantaneous knowledge of all user's requirements or plans for sharing the communication resources. there is no overhead needed to organize the resource allocation, and it is typically implemented at a local site. With multiple accessing, the system controller usually involves the remote accessing of a resource, and there may be a finite amount of time required for the controller to become aware of each user's resource requirements.

Most of the access protocols take advantage of the fact that all these multiple access media are broadcast channels. A broadcast channel is a communication channel in which a signal generated by one transmitter can be received by many receivers. Each multiple access medium has different characteristics which may influence the design of the multiple access protocol.

In packet radio, the radio frequency spectrum is a scarce commodity, and hence the

multiple access protocols must be devised to allow the dynamic allocation of the spectrum to a large population of bursty mobile users.

In satellite communication, satellite channels are characterized by a long propagation delay. This delay is long compared to the transmission time of a packet, thus affect the design of a satellite multiple access protocol.

LAN and MAN are characterized by a large and often variable number of devices requiring interconnection. Thus we face the situation in which a high bandwidth channel with short propagation delay is to be shared by independent users.

1.2 Performance Evaluation and Classification

Multiple access protocols are evaluated according to various criteria. The performance parameters are:

- Average Throughput

High bandwidth utilization is a major objective of a access schemes.

Average throughput provides a measure for the percentage of capacity used in accessing the channel.

Average throughput is defined as the ratio of the number of packets that are successfully transmitted in a very long interval to the maximum number of packets that could have been transmitted with continuous transmission on the channel.

- Average Packet Delay

Average Packet Delay is defined as the time that takes for a packet to access the channel.

The delay is the time from the instant that a packet arrives at a source to the instant that it is successfully received. Thus, the average packet delay is the ratio of the total delay of the packets in a very long interval to the number of packets in the interval.

- Stability

Although for some multiple access schemes, their delay and throughput properties might be satisfactory in the short term, they are quite poor when observed over a long interval of time, then these schemes are unstable. some form of control must be applied to these schemes to achieve stability.

- miscellaneous factors

Multiple access schemes may include other features. Of particular concern in some situations is the ability for an access protocol to simultaneously support traffic of different types, different priorities, with variable message lengths, and different delay constraints.

Multiple access schemes may be classified according to the bandwidth allocation scheme, which may be static or dynamic. Also, the bandwidth allocation scheme may be implemented using a centralized controller or in a distributed manner. In general, multiple access schemes can be classified into the following five main categories,

- Fixed Assignment

Fixed assignment protocols partition the channel into subchannels in the time, frequency or code domain. These subchannels are assigned to the users in a fixed manner independently of their traffic statistics. that is, each station has exclusive ownership of its subchannel whether or not it is actively generating traffic.

- Random Assignment

Random access protocols are characterized by the lack of strict ordering of the stations contending for access to the channel. In a random access scheme, a station is free to broadcast its messages at a time determined locally without any coordination with the other stations. That is, each station transmits packet bursts at random. Systems, in which multiple stations share a common channel in a manner that can lead to conflicts, are widely known as contention schemes.

- Demand Assignment with Distributed Control

The basic idea in Distributed algorithms is the need to exchange control information among the users, either explicitly or implicitly. With this information, all users then independently execute the same algorithm resulting in some coordination in their actions. Distributed demand assignment schemes have two main advantages of reliability and performance. Reliability in distributed control is higher than centralized control, since the system operation is not dependent on a central scheduler. Performance, in terms of delay and channel utilization, is better than centralized schemes.

- Demand Assignment with centralized control

In Demand Assignment Access protocols, stations are required to provide explicit or implicit information regarding their needs for communication bandwidth. In centralized demand assignment schemes, a central unit allocates the requested bandwidth.

Unlike fixed assignment schemes, demand assignment schemes minimize wasted channel bandwidth by avoiding assignment of the channel to idle stations. Also unlike random assignment schemes, demand assignment schemes eliminate channel bandwidth wasted by collision.

Demand assignment schemes perform well for applications that require predictable channel access time and bounded packet delay. However, the overhead in some of these schemes may be large, which leads to inefficiency.

- Hybrid Modes

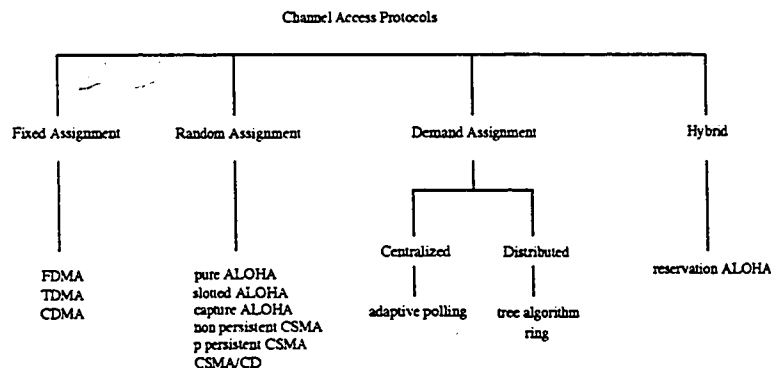

Figure 1.1: the classification of MAC

1.3 Code Division Multiple Access

A long held attraction of spread spectrum communications has been, and continues to be, the possibility of frequency reuse using Code Division Multiple Access (CDMA) systems. Furthermore, there are other applications where CDMA may prove a feasible alternative to traditional multiple-access schemes such as TDMA and FDMA. We introduce the concept of CDMA here and then point out some of its advantage and disadvantages.

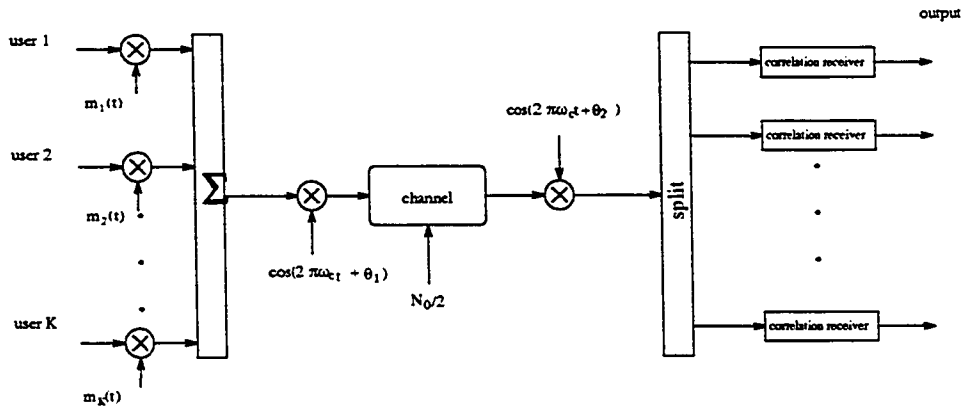

Figure 1.2: a model of CDMA system

1.3.1 The Basic Principles of CDMA

The key idea in a CDMA system is that each user is assigned a distinct PN sequence, so that even when K users transmit in the same frequency band simultaneously, the data from a particular user can be extracted with low bit error probability by correlating the received signal with the particular user's PN sequence. A typical CDMA system block diagram is shown in Fig.1.1.

Consider CDMA networks of binary direct sequence systems. The transmitted signal due to K users in the frequency band W is,

$$s(t) = \sum_{i=1}^K \sqrt{p_i} q_i(t) m_i(t) \cos(\omega_0 t + \theta_i) \quad (1.1)$$

where,

- p_i is the power of transmitted signal at carrier frequency f_0
- q_i is the spreading waveform
- m_i is the data modulation
- ω_0 is the same for all systems in a CDMA network

- θ_i is a random phase

The random phase θ_i is assumed statistically independent of all θ_j , $j \neq i$. The signal at the receiver front end is thus,

$$r(t) = s(t) + n(t) \quad (1.2)$$

where, $n(t)$ is the thermal noise.

If we assume that the received signal power from each user is the same, so the bit error probability for the i th user is,

$$P_{e,i} = \frac{1}{2} - \operatorname{erf} \left[\frac{2E_s}{N_0 + (K-1)P_s/2W} \right] \quad (1.3)$$

if we neglect thermal noise, N_0 , this simplifies to,

$$P_{e,i} = \frac{1}{2} - \operatorname{erf} \left[\frac{2E_s}{(K-1)P_s/2W} \right] \quad (1.4)$$

or in term of processing gain,

$$P_{e,i} = \frac{1}{2} - \operatorname{erf} \left[\frac{4 \cdot \text{PG}}{K-1} \right] \quad (1.5)$$

Eq.1.5 shows that the bit error probability decreases with increasing processing gain, and from Eq.1.5 we can evaluate the number of users which the system can support. We have to note that it was assumed that all users have the same received power level and that the PN sequences are mutually orthogonal. Of course, the problem of finding good PN sequences is a long-standing one, and mutual orthogonality is not easy to achieve in practice. For ground based systems such as cellular mobile radio or satellite systems, the received power levels from different users are often unequal since some users are closer to the receiver than others.

The problem of unequal received power levels for different users is called the *Near-far* problem. One system modification that compensates for unequal received power levels is to transmit a pilot signal so that the user can determine the path loss and hence the required transmitted power level. This technique is used in a mobile satellite application.

1.3.2 CDMA system design issue

There is an interesting contrast between CDMA systems and FDMA or TDMA systems. In FDMA or TDMA, the number of users is constrained by the number of slots available in frequency or time, respectively. Once these slots are full, additional users can be accommodated only by a system redesign. For CDMA, however, the number of users is constrained by performance. New users can always be added, but the performance for all users will degrade according to Eq.1.5.

A CDMA system can be hybrid of FDMA and CDMA techniques where the total system bandwidth is divided into a set of wideband channels, each of which contains a large number of CDMA signals. Hybrids of TDMA and CDMA are also a possible, where the time axis is divided into a set of time slots, each time slot contains a large number of CDMA signals.

The CDMA digital cellular waveform design uses a PN spread spectrum carrier. The chip rate of the PN sequence is chosen so that the resulting bandwidth is about one-tenth of the total bandwidth allocated to one cellular service carrier.

PN binary codes are used to distinguish signals received at a mobile station from different base stations. All CDMA signals in the system share a quadrature pair of PN codes. Signals from different cells are distinguished by time offsets from the basic code.

This relies on the property of PN codes that the autocorrelation, when averaged over a few bit times, averages to zero for all time offsets greater than a single code chip time.

An important aspect of the forward link waveform design is the use of the pilot signal that is transmitted by each cell-site and is used as a coherent carrier reference for demodulation by all mobile receivers.

The CDMA frequency reuse efficiency is determined by the processing gain. Since the total capacity becomes quite large, the statistics of the number of the users is important. The net interference to any given signal is the average of all users' received power times the number of users. As long as the ratio of received signal power to the average noise power density is greater than a threshold value, then the channel will provide an acceptable signal quality.

1.3.3 The Applications of CDMA

CDMA is a modulation and multiple access scheme based on spread spectrum communications techniques, a well established technology that has been applied only recently to digital cellular radio communications and advanced wireless technologies such as personal communications network (PCN). It solves the near-term capacity concerns of major markets and answers the industry's long-term need for a next generation technology for truly portable communications in the most economic and efficient manner providing for a graceful evolution into the future generations of wireless technologies.

Although first terrestrial application of the CDMA is for the development of the next generation digital cellular system, it is important to realize that the CDMA technology being developed, and the chip-set " engines" could be cost effectively used in many other important applications. the major wireless personal communications applications are,

- CDMA for private microcellular systems
- public cordless systems
- wireless local area networks
- wireless PABX

Two most widely used CDMA techniques are,

- Direct Sequence CDMA
 - Synchronized DS-CDMA
 - Nonsynchronized DS-CDMA
 - Orthogonal DS-CDMA
 - Nonorthogonal DS-CDMA
- Frequency Hopped CDMA

The application of CDMA is usually not attractive from a capacity viewpoint alone. One or more of the following desirable objectives can be accomplished with CDMA,

- reduce the spectral density
- provide protection against jamming
- provide message privacy
- combat multipath in mobile communication system
- conduct precise range measurements

There are of course, a number of disadvantages associated with CDMA, the two most obvious of which are the problem of “ self-jamming ” and the related problem of the “ near-far ” effect. The “ self-jamming ” arises from the fact that in an asynchronous CDMA

networks. The spreading sequences of the different users are not orthogonal, and hence in the despreading of a given user's test statistic arise from the transmissions of the other users in the network. This is as distinct from either TDMA or FDMA, wherein for reasonable time or frequency guardbands, respectively, orthogonality of the received signals can be preserved.

Given that such orthogonality cannot be preserved in CDMA, the obvious point of interest is to determine how much degradation in system performance results. From a quantitative point of view, there are many analyses and bounding techniques available to answer this question.

Qualitatively, we can easily see two major areas of concern for the specific application of digital cellular radio. The first is the propagation law, because these channels typically have multiple reflections associated with them, the net propagation law is not that which would be observed over a free space channel. Measurements have indicated that the received power falls off roughly as the inverse of the distance between the transmitter and the receiver raised to a power that is somewhere between two and four, and because of the potentially large number of users causing the multiple access interference, there can be a noticeable difference in performance depending on which power law is used for performance computations.

1.3.4 CDMA satellite systems

In CDMA satellite systems, uplink stations are identified by uniquely separable address codes embedded within the carrier waveform. Each uplink station uses the entire satellite bandwidth and transmits through the satellite whenever desired, with all active stations superimposing their waveforms on the downlink. Thus no frequency or time separation is

required. Carrier separation is achieved at an earth station by identifying the carrier with the proper address. These addresses are usually in the form of periodic binary sequences from DS system or from FH system. Address identification is accomplished by carrier correlation operations. CDMA carrier crosstalk occurs only in the inability to correlate out the undesired addresses while properly synchronizing to the correct address for decoding. CDMA carriers have the use of the entire satellite bandwidth for their total activity period, and CDMA has the advantage that no controlled uplink transmission time is required, and no uniformity over station bit rates is imposed. However, system performance depends quite heavily on the ability to recognize addresses, which often becomes difficult if the number of stations in the system is large.

Digital addresses are obtained from code generators that produce periodic sequences of binary symbols. A stations address generator continually cycles through its address sequence, which is superimposed on the carrier along with the data. If the address is modulated directly on the carrier, the system is referred to direct sequence CDMA (DS-CDMA). If the digital address is used to continually change the frequency of the carrier, the system is referred to as frequency hopped CDMA (FH-CDMA). Superimposing addresses on modulated uplink carriers generally produces a large carrier bandwidth than that which will be generated by the modulation alone. This spreading of the carrier spectrum has caused CDMA system to be referred to also as spread spectrum multiple access (SSMA) system.

To analyze the performance of CDMA with a hard limiting satellite repeater, the time synchronization between transmitter and receiver is assumed. The maximum number of identical users K in a band W which can be supported by the satellite downlink is given by [],

$$K = \frac{\pi/4}{R_c(E_b/N_0)} \cdot \frac{P_r}{N_r + N_j} \quad (1.6)$$

$$N_j = \frac{P_r}{W} \cdot \left(\frac{K-1}{K}\right) \simeq \frac{P_r}{W} \quad (1.7)$$

where,

- P_r is the total satellite power arriving at the receiver
- R_c is the chip rate assumed to be the same for all transmitters
- N_r is the noise density at the receiver
- N_j is the equivalent noise density generated by the $K - 1$ users to which the given receiver is not tuned

The factor $\pi/4$ accounts for the intermodulation loss in a hard limiter for a signal in Gaussian noise. If the bandwidth is large enough for N_r to dominate N_j such that $(P_r/N_r W) \ll 1$, we are in the “power limited” region. In this situation the maximum number of users is the same as in an orthogonal system operating at the same E_b/N_0 . Conversely, for W is small, such that $(P_r/N_r W) > 1$, we are in the “bandwidth limited” region. The multiple access noise density N_j dominates and CDMA is rather inefficient.

1.3.5 Cellular CDMA

The CDMA scheme was developed mainly to increase capacity. The development of digital cellular systems for increasing capacity came just as the analog cellular system faced a capacity limitation in 1987. In digital systems there are three basic multiple access schemes: FDMA, TDMA and CDMA. In theory, it does not matter whether the spectrum is divided into frequencies, time slots or codes. The capacity provided from these three multiple access

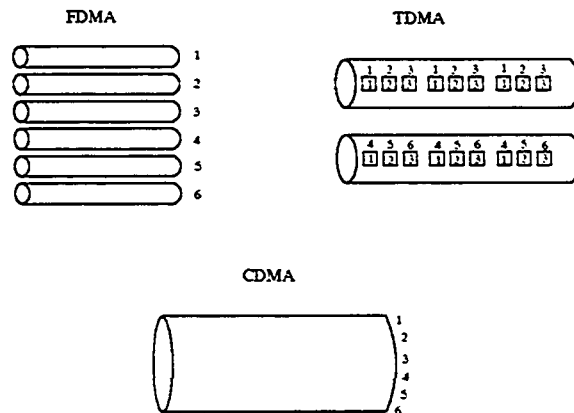

Figure 1.3: illustration of different multiple access system

schemes is the same. However, in the cellular system we might find that one is better suited in certain communication media than another. In the North American cellular system, in particular, no additional spectrum is allocated for digital cellular, so the analog and digital systems coexist in the spectrum. The problem of transition from analog to digital is another consideration. Although the CDMA has been used in satellite communications, the same system can not be directly applied to the mobile cellular system. The characteristics of CDMA are suitable for the mobile radio environment.

In a CDMA system the propagation of a wideband carrier signal is used, whereas the propagation of narrowband carrier signal is a conventional means of communication.

Multiple access scheme are used to provide resources for establishing calls. FDMA, TDMA and CDMA can all be applied in the cellular systems. The illustration of the differences among three multiple access schemes are shown in Fig.1.2. Assume that a set of six channels is assigned to a cell.

In FDMA six frequency channels serve six calls. In TDMA the channel bandwidth is three times wider than that of FDMA channel bandwidth. Thus two TDMA channel bandwidths equal six FDMA channel bandwidths, with each TDMA channel providing three time slots. The total six time slots serves six calls. In CDMA one big channel has a

bandwidth equal to six FDMA channels. The CDMA radio channel can provide six code sequences and serve six calls. Also, CDMA can squeeze additional code sequences into the same radio channel, but the FDMA and TDMA cannot. Adding more code sequences of course degrades the voice quality.

Cellular CDMA is uniquely designed to work in cellular systems. the primary purpose of using this CDMA is for high capacity. In cellular CDMA there are two CIRF values. One CIRF is called adjacent CIRF. it means that the same radio channel can be reused in all neighboring cells. The other CIRF is called self CIRF. It means that different code sequences use the same radio channel to carry different traffic channels. With the smallest value of CIRF, the CDMA system is the most efficient frequency reuse system we can find.

There are many advantage to using CDMA in the cellular system.

- Voice activity cycles

CDMA can take the natural shape of human conversation. The human voice activity cycle is 35%. The rest of the time we are either listening or pausing. In CDMA all the users are sharing one radio channel. When users assigned to the channel are not talking, all others on the channel benefit with less interface in a single CDMA radio channel. This, the voice activity cycle reduces mutual interface by 65% tripling the true channel capacity. CDMA is the only technology that takes advantage of this phenomenon.

- No equalizer needed

When the transmission rate is much higher than 10 kbps in both FDMA and TDMA, an equalizer is needed to reduce the intersymbol interference caused by time delay spread. However, in CDMA only a correlator is needed

at the receiver end to recover the desired signal from despreding the SS signal. The correlator is simpler to install than the equalizer.

- One radio per site

Only one radio is needed at each site or at each sector. It saves equipment space and is easy to install.

- No hard hand off

Since every cell uses the same CDMA radio, the only difference is in the code sequences. There is no hand-off from one frequency to another while it moves from cell to cell. However a code sequence will be changed from one cell to another cell. This is called soft hand-off.

- No guard time in CDMA

Guard time is required in TDMA between time slots. Guard time does occupy the time periods of certain bits. The waste bits could be used to improve quality performance in CDMA. In CDMA Guard time does not exist.

- Sectorization for capacity

In FDMA and TDMA each cell is divided into sectors in order to reduce interference. As a result the trunking efficiency of dividing channels in each sector decreases. In CDMA sectorization is used to increase capacity in a way that introduces three radios in three sectors and therefore obtains three times the capacity as compared with the theoretical one radio in a cell.

- Less fading

Less fading is observed in the wideband signal while it propagates in a mobile radio environment. It is more advantageous to use a wideband signal in urban areas than in suburban areas[10]

- No frequency management or assignment needed.

In FDMA and TDMA the frequency management is always a critical task. Since there is only one common radio channel in CDMA, no frequency management is needed. Also, to reduce real time interference, a dynamic frequency assignment has to be implemented in TDMA and FDMA. This calls for a linear broadband power amplifier which is hard to develop. CDMA does not need a dynamic frequency assignment.

- soft capacity

In CDMA all the traffic channels share one CDMA radio channel. We can add an additional user so that the voice quality is just slightly degraded as compared to that of the normal 40-channel cell.

- Coexistence

Both analog and CDMA systems can operate in two different spectra. CDMA only needs 10% of bandwidth to general 200% of capacity, so there is no interference between the two systems.

- For microcell and in-building systems.

CDMA is a natural waveform suitable for microcell and in-building because it is acceptable to noise and interference.

This summary of CDMA highlights the potential of increasing capacity in future cellular communications. Two papers[8][9] analyzed CDMA in depth.

Bibliography

- [1] IEEE Workshop on Spread Spectrum Potential Commercial Applications, Montobello, Quebec, Canada, May 1991.
- [2] N.Nakagawa and T.Hasegawa, " Spread Spectrum for Consumer Communication Applications of Spread Spectrum Communications in Japan" IEICE Trans., vol.E74, no.5, May 1991
- [3] R.L.Pickholtz, D.L.Schilling and L.B.Milstein, "Theory of spread spectrum communications - A tutorial" IEEE Trans. Commun., vol. COM-30, May 1982
- [4] M.L.Dukic, Z.D.Stojanovic and I.S.Stojanovic, " Performance of Direct Sequence Spread Spectrum Receiver Using Decision Feedback and Transversal Filters For Combating Interference" IEEE J.Select. Areas Comm. SAC-8 Jun 1990
- [5] A.K.Elhakeem, M.A.Rahman, P.B.Balasubramanian and T.L.Ngoc, "Modified SUGAR/DS - A new CDMA scheme" IEEE J.Select. Areas Comm. vol SAC-10 May 1992
- [6] A.K.Elhakeem, R.D.Girolamo, B.B.Ilyess and M.Talla, " Delay and Throughput Characteristics of TH, CDMA, TDMA and Hybrid Networks for

Multipath Faded data Transmission Channels" IEEE J.Select. Areas Comm.
vol.12 may 1994

- [7] K.G.Johannsen "CDMA Versus FDMA Channel capacity in Mobile satellite Communication" IEEE Trans. Vehicular tech. vol.39 February 1990
- [8] K.S.Gilhousen, I.M.Jacobs, R.Padovani, A.J.Viterbi, L.A.Weaverand C.E.Wheatley, " On the Capacity of a Cellular CDMA System" IEEE Trans. Veh. Tech.:vol.40 May 1991
- [9] R.L.Pickholtz, L.B.Milstein and D.L.Schilling, " Spread Spectrum for mobile Communications" IEEE Trans. Veh. Tech. vol40 May 1991
- [10] W.C.Y.Lee, " Overview of Cellular CDMA" IEEE Trans. on Vehicular Technology, vol.40, May 1991

Chapter 2

Introduction to ATM

The BISDN's fundamental objective is to achieve complete integration of services ranging from low bit rate bursty signals up to broadband continuous real time signals, including voiceband services such as telemetry, data terminal, telephone, facsimile, and broadband services such as video signal transmission. Consequently, an efficient technique for dealing with such a diverse set of services in a generalized manner was desired, and ATM is the technique that was proposed as the solution.

BISDN is also required to meet diverse service and performance requirements of multimedia traffic. Real time voice, for example, requires rapid transfer through a network, but the loss of small amounts of voice information is tolerable. In many data applications, real time delivery is not of primary importance, but high throughput and strict error control are required.

In the background surrounding the emergence of the BISDN concept, there is an increasing demand for various types of broadband services, including video services. In order to accommodate all such broadband signals, the capability to integrate interactive services such as video telephone with distributive services like CATV is needed, as well

as the capability to provide both the circuit mode services and packet mode services in a generalized manner. In addition, a technique that enables the joint accommodation of signals over a wide range of frequencies is also required, the various signals can be,

- low rate telemetry signals – a few bits per seconds
- midrange voice speed signals – tens of kilobits per seconds
- high rate video signals – hundreds of megabits per seconds

A possible solution for meeting this requirements is the scheme in which various service signals are first made to have a common external shape and then are piled up one by one and multiplexed together. Here, the ATM cell is the standardized external form, and the method for multiplexing a collection of ATM cells is ATDM. The communication mode based on ATM cells and the ATDM is the **Asynchronous Transfer Mode**.

2.1 Asynchronous Transfer Mode (ATM)

The ATM communication technique can be said to be a transfer mode that integrated the existing circuit mode digital transfer method with the packet mode transfer method. The synchronous transfer mode (STM) is a circuit switching based technique. STM was initially considered an appropriated transfer mode for BISDN because of its compatibility with existing systems. In STM, bandwidth is organized in a periodic frame, which consists of time slots. A framing slot indicates the start of each frame, and each slot in an STM frame is assigned to a particular call, and the call is identified by the position of the slot. In STM, slots are assigned based on the peak transfer rate of the call, thus, the required service quality can be guaranteed even at the peak load. STM is suitable for fixed rate service. STM can not support traffic efficiently, because, in STM, bandwidth is wasted

during the period in which information is transported below peak rate. Fig.2.1 illustrates the differences between STM and ATM.

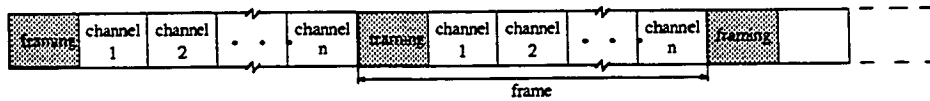

(a) STM multiplexing

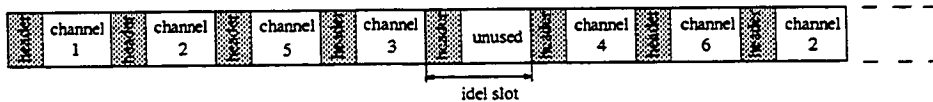

(b) ATM multiplexing

Figure 2.1: STM and ATM multiplexing

ATM has a close connection with the packet mode transfer method in that it uses ATM cells as its basic means of transport, but there is a difference in that the packet mode was created for variable rate, non real time data signals, whereas ATM can manage real time fixed rate signals as well. Also, the packet mode is generally used for LANs, whereas ATM can be used for a vast public network and is hence accompanied by various problems inherent in any large network, such routing, access and flow control, switching and transmission. on the other hand, the fundamental difference between ATM and the STM is that whereas the STM functions by allocating a separate service channel and transferring through it information signals in a continuous bit stream, ATM operates by segmenting the information signal so as to fit onto the ATM cell, then transferring it through a virtual channel. Thus, the accompanying ATM procedures such as connection setup, data processing, transmission and switching raise various new problems.

ATM is the communication technique conceived as a way of materializing the BISDN and is a packet-mode transport technique with a peculiar form that employs ATDM. In

a BISDN, information is transferred through a continuous flow of packets of fixed size called *ATM cells*. Consequently, service information is first curtailed to a fixed size, then mapped into the ATM cells, and subsequently goes through the ATDM procedure with other ATM cells, thus forming the BISDN's internal transmission signal. ATDM is a type of statistical multiplexing technique that time division multiplexes ATM cells from several different channels arriving in a mutually asynchronous manner.

ATM is a connection oriented method of communication that establishes virtual channel for the transfer of ATM cells. Thus, the use of ATM allows highly flexible network access and variable assignment of bandwidth. Also, since ATM is defined independently of the particular transport means of the physical layer, information transfer can be accomplished through diverse types of physical media and transport networks.

2.2 Standardization of ATM

In the CCITT Recommendation I.121, a guideline for future BISDN standardization, ATM has been accepted as the final transfer mode for BISDN. According to this recommendation, information flow in ATM is organized into fixed size cells, each consisting of a header and an information field. Fixed size cells are chosen over variable size units because, based on the state of the existing experimental fast packet switching technology, it is believed that fixed size cells can be switched more efficiently. These cells are transmitted over a virtual circuit are identified by the header.

2.2.1 ATM cell

The size of an ATM cell should be small in order to reduce the degrading effect of the packetization delay at the source. For instance, considerable delay could be introduced

during creation of a voice cell if the size of a cell is large. T1S1, a body commissioned by the American National Standards Institute (ANSI) to develop ISDN standards for North America, had proposed an ATM cell consisting of a 5 octet header and a 64 octet information field, while the ETSI, a regional organization that coordinates telecommunications policies in Europe, had proposed an ATM cell consisting of a 4 octet header and a 32 octet information field. The CCITT header formats which will be used at user network interface (UNI) and network node interface (NNI) are shown in Fig.2.2.

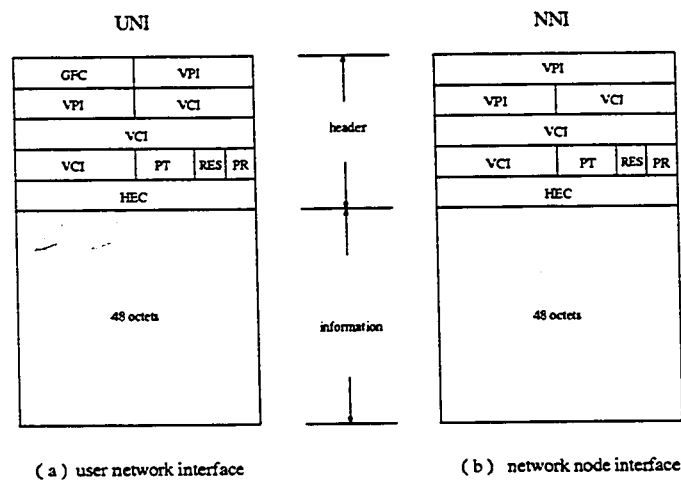

Figure 2.2: ATM cell structure

The cell header consists of,

- **GFC**

Generic Flow Control is a 4 bit field defined at the UNI to assist the user in controlling their traffic flow according to a certain quality of service. There is no GFC in NNI.

- **VCI**

Virtual Channel Identifier is a 16 bit field at the UNI and NNI. VCI identifies a particular end-to-end switched connection and deals with the switching functions of cells belonging to a certain logical connection. The value of the VCI may change as the cell traverses the network.

- **VPI**

Virtual Path Identifier is a 8 bit field defined at UNI and 12 bit at NNI. VPI consists of a bundle of virtual channels which are transported on the same physical media. It deals with the cross connection functions of the cells.

- **PT**

Payload Type is a 2 bit field at UNI and NNI. PT is used to distinguish the network information from the user information.

- **RES**

a 1 bit reserved field which is used as the payload type identifier.

- **PR**

a 1 bit priority field which is used to indicate the loss priority by the end point and to indicate selective cell discarding in network switches. if $PR = 0$, the cell has normal priority for traffic congestion control. If $PR = 1$, the cell has lower priority which may be subject to discard depending on the network traffic conditions.

- **HEC**

Header Error Control is a 8 bit field used for error detection and correction capabilities on the cell header. the polynomial used to generate the header

error check value is $X^8 + X^2 + X + 1$. The transmitter calculates the HEC value for the first four octets of the cell header and inserts the results into the HEC field.

2.2.2 ATM Network Layer Structure

Some agreement of layered architectures for ATM networks has been made in the CCITT study group XVIII meeting held in June 1989. Fig.2.3 shows a BISDN ATM protocol model. In this figure, the protocol hierarchy consists of the physical layer, the ATM layer, the adaptation layer and higher service layer. Note that functional layering in the BISDN protocol model does not follow the OSI model.[10]

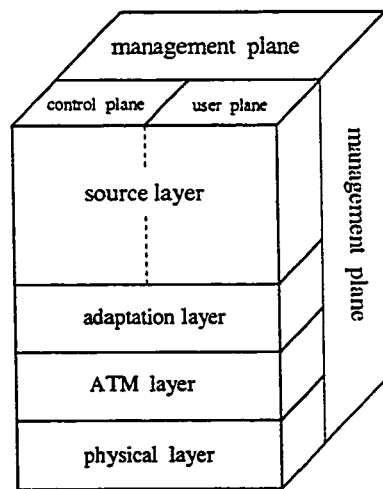

Figure 2.3: BISDN ATM protocol mode

The physical layer allows either the use of the SONET format or the ATDM format at the user network interface. This layer is responsible for the proper bit transmission and performs functions such as to insert the cell flow into a transmission frame.

The ATM layer contains all the details of the ATM technique, and it is common to all services. This layer is physical medium independent, and thus it is independent of the underlying physical layer. The data unit of this layer is an ATM cell, and the ATM layer performs the cell header functions. ATM layer also performs cell based multiplexing and cell delineation. The information field of an ATM cell is passed transparently through the ATM layer, and no processing, including error control, is performed on the information field at the ATM layer.

ATM is a connection oriented technique. The ATM uses two connection concepts, the virtual channel and the virtual path. A virtual channel provides a logical connection between end users. A virtual path defines a collection of virtual circuits traversing the same path in the network. The concept of virtual path provides the tool to implement an efficient and flexible traffic control functions at network level. Virtual paths define the cross-connection concerned with switching and connection establishment functions.

The adaptation layer and the source layers of the ATM protocol are service dependent, this means the adaptation layer supports information transfer protocols which are not based on ATM, adaptation layer represents the link between many BISDN services and ATM. The adaptation layer provides the source layers with the necessary functions which are not provided by ATM layer, such as preserving timing, data frame boundaries and source clock.

2.3 ATM transmission Structure

The BISDN is based on transmission speeds and capacities at the 155 Mbps, 622 Mbps, and 2.4 Gbps levels. The associated standards include CCITT *G* Series Recommendations for SDH, SONET standards of the T1 Committee, and the CCITT *I* Series Recommendations, which support the concept of ATM based BISDN. Here, SDH is a novel system whose goal is

integrated accommodation of the existing PDH (Plesiochronous Digital Hierarchy), while ATM is an attempt to accommodate packet mode transmission inside existing circuit mode communication networks. Consequently, the BISDN can be said to be a highly innovative communication network in many respects compared to existing communication networks.

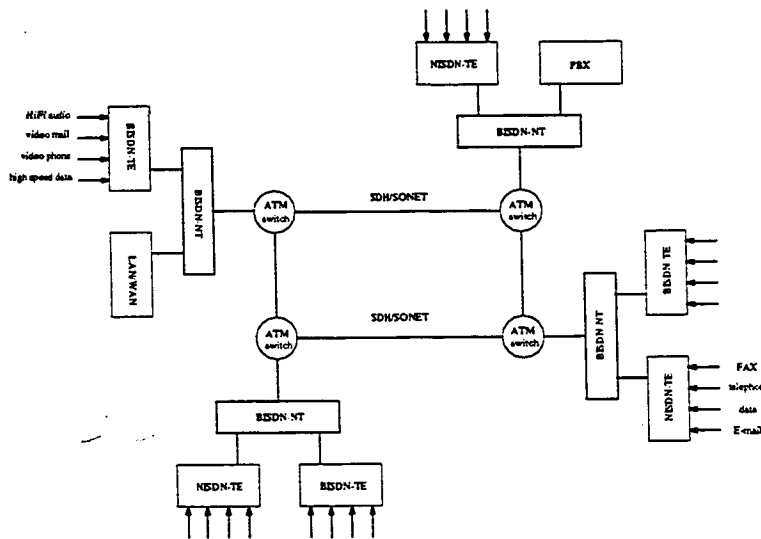

Figure 2.4: a conceptual structure of the BISDN

Fig.2.4 shows the conceptual composition of the BISDN. It can be observed that SDH/SONET is used as transmission and ATM is used as switching modes. And that BISDN NT (Network Terminal) are used for broad band access. It can also be inferred from Fig.2.4 that, in BISDN, existing NISDN services and various new broadband services are accommodated collectively and that PBX (Private Branch Exchange) and LAN/WAN can be interconnected.

T1S1 and ETSI disagrees on the transmission structure under laying the ATM layer. T1S1 favors the SONET approach, and ETSI favors the ATDM approach. In the ATDM approach, no frame structure is imposed on UNI, and all of its physical bandwidth is organized as ATM cells. In the SONET approach, ATM cells are carried within the

payload of another framework, such as SONET frame, the payload is an area used to carry the service or signal being transported.

CCITT will standardize two physical interfaces to BISDN. One based on SONET and the other based on a variation of ATDM [8]. The UNI interface rate for both of these is set at 155.52 Mbits/s [8].

2.3.1 ATDM

ATDM is a type of multiplexing technique that stores each of the incoming low speed signals inside a buffer, then retrieves and inserts the stored signals one by one into a multiplexing slot according to a priority scheduling principle. The simplest example of the priority scheduling principle would be **first-in first-out, FIFO**. Fig.2.5 shows the ATDM concept.

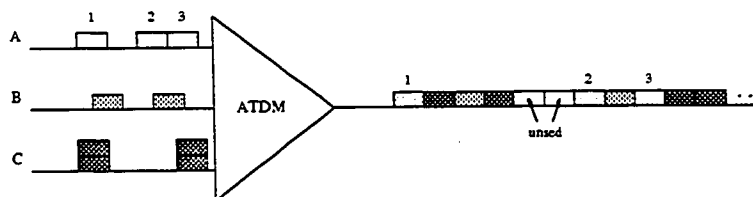

Figure 2.5: the ATDM concept

In the ATM communication systems, the input signals are ATM cells. The low speed input signals do not occupy locations inside the ATDM signal in a well regulated manner. ATDM is a frameless interface carrying no synchronous channel [5], Fig.2.6 shows the ATDM structure. ATDM consists of cells only, the synchronization is maintained by filling empty cells with a special synchronization pattern. The advantage of using ATDM as a transmission structure underlying the ATM layer is the simplified interface which results when both transmission and transfer mode functions are based on a common structure.

ETSI favors this approach. The ATD approach, combined with efficient variable bit rate coding methods and network flow control techniques, can deliver the service without circuit switching.

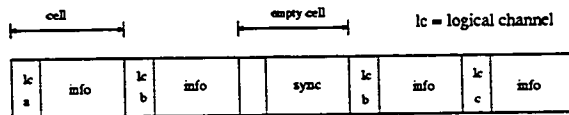

Figure 2.6: the ATDM structure

2.3.2 SONET

Synchronous Optical Network originally proposed by Bell Communications Research, it is a standard optical interface. In SONET, there is a basic building block called the synchronous transport signal level 1 frame (STS-1). The STS-1 frame has a bit rate of 51.84 Mbits/s and repeats every 125μ seconds. A $125\mu sec$ frame period supports digital voice signal transport since each byte can represent a 64 kbits/s DS0 channel. The STS-1 frame structure is illustrated in Fig.2.7, it consists of 9 row an 90 columns, and it is transmitted row by row, and from left to right.

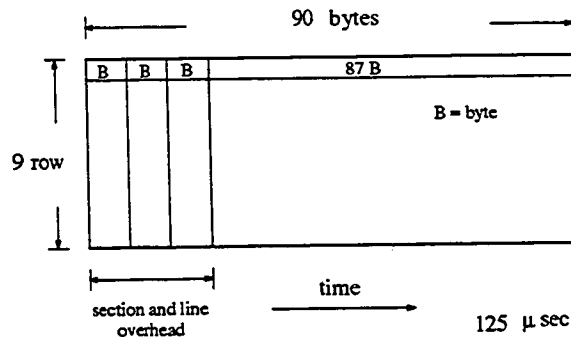

Figure 2.7: STS-1 frame structure

The STS-1 frame is divided into two areas known as the transport overhead and the synchronous payload envelope (SPE). The transport overhead is used to carry overhead information and the SPE is used to carry the SONET payload. In the SPE, there is one column of path overhead. A path corresponds to a logical connection between source and destination. The SONET SPE can be used to carry either ATM based or STM based payloads.

The transport overhead carries information necessary for secure transmission of the SPE. The overhead bits is used for connections at the section level and the line level. The Fig.2.8 shows the concept of section and line. The section overhead is processed at each regenerator. The line overhead is passed transparently through regenerators and is processed by light wave terminating equipment.

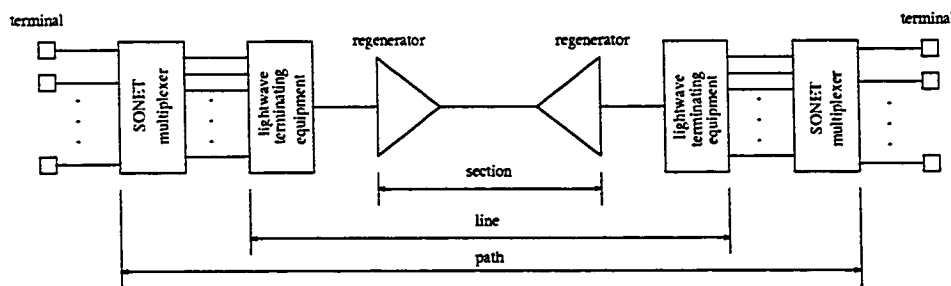

Figure 2.8: the concepts of section, line and path

Higher rate SONET signals are obtained by synchronously byte multiplexing N STS-1 frames, called STS- N frame, Fig.2.9 shows the STS- N frame structure. It consists of 9 rows and $N \times 90$ columns, and there are $N \times 1$ columns of path overhead. The transport overhead consists of $N \times 3$ columns. The aggregated bit rate of an STS- N signal is exactly N times the basic rate of 51.84 Mbits/s. Currently, the only values of N allowed are 1, 3, 9, 12, 18, 24, 36 and 48. The optical signal of STS- N is called $OC - N$, Optical Carrier Level N . The $OC-N$ will have a line rate exactly same as the STS- N .

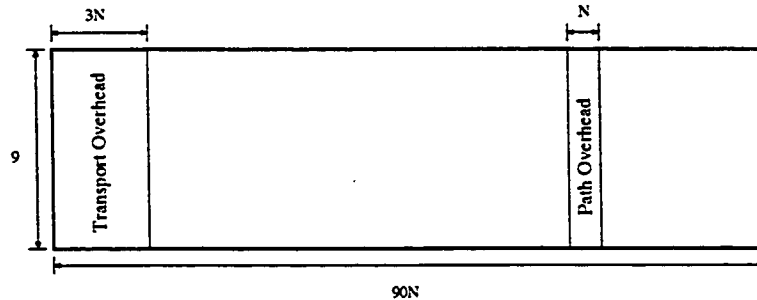

Figure 2.9: STS-N frame structure

ATM within SONET

The SONET frame structure helps maintain synchronization of transmitted data stream. If it is used to transmit ATM data, successive ATM cells are placed in the data portion of SONET frames in the manner indicated in Fig.2.10. In the figure, it is assumed that the UNI of the ATM cell is SONET based and uses the STS-3c format with a gross bit rate of 155.52 Mbits/s. It is proposed that the SONET STS-3c frame is usually used in BISDN [4].

SONET overhead is not embedded within the cell structure, and the SONET payload carries ATM cells multiplexed using ATM techniques. T1S1 favors SONET over ATDM because of the following reasons[9],

1. SONET makes the transition from the existing networks to ATM networks easier than ATDM
2. Some specific connection can be circuit switched using a SONET channel.
3. Using SONET synchronous multiplexing capabilities, several ATM streams can be combined to build interfaces with higher bit rates than those supported by ATM layer.

Because SONET requires more circuit switching, it can support some classes of traffic that may be more suitable for circuit switching such as broadcast television.

Another possible disadvantage of using SONET is that existing equipment may not be SONET compatible.

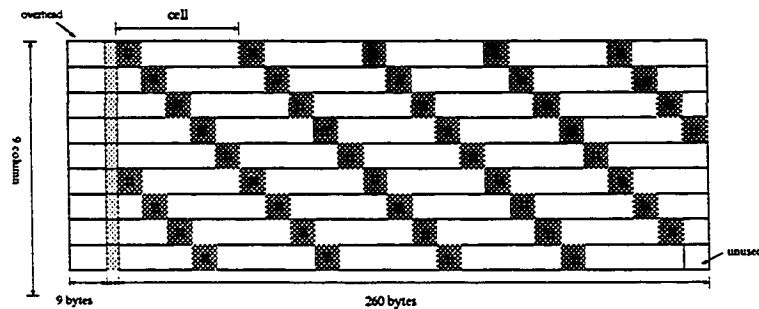

Figure 2.10: ATM within SONET

2.4 Congestion Control in ATM Networks

In an ATM network, most traffic sources are bursty. A bursty source may generate cells at a near peak rate for very short period of time and immediately afterwards it may become inactive and do not generate cells. Such a bursty traffic source will not require continuous allocation of bandwidth at its peak rate. Since an ATM network supports a large number of such bursty traffic sources, statistical multiplexing can be used to gain bandwidth efficiency, allowing more traffic sources to share the bandwidth. However, if a large number of traffic sources become active simultaneously, several network congestion can result. Congestion control is necessary to control the probability of congestion occurrence and possibly to minimize the impact of congestion on the end users.

Congestion control in an ATM network is a challenge because of the effects of high speed channels significantly limit the congestion control schemes applicable. Thus some of

the congestion control schemes developed for existing networks may no longer be applicable in such a high speed network. New congestion control schemes for ATM networks are needed and have been proposed.

2.4.1 Objectives of ATM Congestion Control

Performance requirements during the information transfer phase of a VC can range from stringent cell delay variation for delay sensitive isochronous services to stringent cell loss probabilities for loss sensitive services. In managing the wide range of traffic types and performance requirements, the key challenge is the equitable and efficient allocation of network resources such that the admission of new VC does not adversely affect the performance of other VCs sharing those network resources.

Therefore, congestion control schemes are required to ensure that sufficient bandwidth and satisfactory performance are provided to all accepted VCs at the same time remaining operationally simple, easy to implement and robust to evolving ATM traffic characteristics.

Proposed CCITT recommendation I.311 indicates the following four objectives for ATM layer congestion control.

- ATM layer congestion controls should not rely on ATM adaptation layer or higher layer protocols.
- ATM layer congestion controls should be optimal considering the tradeoff between system complexity and network efficiency
- ATM layer congestion controls should support a set of ATM layer QOS classes sufficient for all foreseeable BISDN services
- ATM layer congestion controls should attempt to maintain the VC's QOS even under congestion conditions.

2.4.2 Congestion Control Schemes for ATM network

The congestion control schemes has been classified into two categories,

- **preventive control**

take actions to prevent congestion from occurring

- **reactive control**

take actions to recover from congestion once it occurs

Most ATM network congestion control approaches fall in class of preventive control. Reactive control does not perform well in ATM networks, because reactive control instructs the source node to shuttle their traffic flow by giving feedback to them, in high speed networks, the feedback may be too late to react effectively.

Preventive controls try to prevent the ATM network from reaching an unacceptable level of congestion. The most common and effective approach is control traffic flow at the access node of the networks. This approach is especially effective in ATM NETWORKS because of its connection oriented transport. With connection oriented transport, a decision to admit new traffic can be made based on the knowledge of the state of the route which the traffic would follow.

Preventive control for ATM can be performed in two ways,

- Admission Control
- Bandwidth Enforcement

Admission control determines whether to accept or reject a new connection at the time of call setup. This decision is based on traffic characteristics of the new connection and the current network load. The bandwidth enforcement monitors individual connections to ensure that the actual traffic flow conforms with that reported at call establishment.

Admission Control

The admission control provides the main method of controlling the traffic performance of the network. When a request for a new connection is received, the network examines its service requirements, traffic characteristics and the current load, and then makes the decision to either accept or deny the connection request. It is obvious that a conservative admission policy allows relatively low loading on the network elements and will minimize the probability of cell level congestion. However, this kind of approach would result in higher level of connection blocking relative to a more aggressive connection admission policy. This provides the ability to trade off blocking probability against probability of congestion. To implement an effective admission control policy, the following issues have to be addressed.

1. what traffic parameters are required to accurately predict network performance?

When a new connection is requested, the network need to know the traffic characteristics of the new connection in order to accurately predict its ability to maintain a certain performance level. A set of traffic descriptors given from a user to a network should include sufficient parameters so that the network can accurately determine the user's traffic characteristics, the set of traffic descriptors should include the fewest possible parameters. The peak rate, the average bit rate and a measure of burstness are the most commonly used parameters for traffic descriptors.

2. what criteria should the network use to decide whether or not to admit a new connection ?

The cell transmission delays and the cell loss probabilities are the most commonly used decision criteria in admission control. There are two basic approaches to apply transmission delays and the cell loss probabilities in admission control, one is the long term time averaged value, the other is the instantaneous cell loss probability.

Using a long term time averaged value may not be sufficient in an ATM network because the ATM network traffic can change rapidly and dynamically, this forcing the network to move from one degree of congestion to another. When the network traffic is highly bursty and changes dynamically, temporal network congestion can occur, and it is possible that a large number of cells are lost during congestion periods, even when the long term time averaged value of loss rate is kept small. Therefore, some decision criteria which take the temporal behavior of the network into account may be needed.

An instantaneous cell loss probability is proposed and used as a decision criterion to consider the temporal behavior of a network [11]. An instantaneous cell loss probability is a time dependent cell loss probability, not the value averaged over a long period of time. A new connection is accepted by the network only when the instantaneous cell loss rate is kept below a threshold value at each switching node for longer than a predetermined percentage of time.

3. how does network performance depend on various traffic parameters?

The traffic parameters have the effects of statistical multiplexing of bursty sources in ATM networks. some common observations are,

- As the average burst length increases, the performance degrades.
- As the peak rate of each source is increased, the cell loss probability increases.
- As the number of sources multiplexed increases, the cell loss probability decreases.
- When high bite rate sources are multiplexed, the fluctuation in the cell loss is larger than when low bit rate sources are multiplexed.
- As the offered load decreases, the cell loss probability decreases.

Policing Mechanism

Since users may deliberately exceed the traffic volume declared at the call setup and overload the network, thus admission control alone is not sufficient.

After a connection is accepted, traffic flow of the connection must be monitored to ensure that the actual traffic flow confirm with that specified at call establishment. For this purpose, the cell policing is implemented at the ATM level of the network. Once a violation is detected, the traffic flow is enforced by discarding or buffering the violating cells.

The policing function must be available for every connection during the entire active phase and must operate in real time. These requirements imply that the policing mechanism used be fast, simple and cost effective to implement in hardware. Ideally, the policing mechanism should be transparent for connections that respect the traffic contract and take no policing actions on their cells. On the other hand, it should act on all cells violating the contract to limit the behavior of the source in the intended way. From these requirements, an ideal limit curve for the policing function can be derived. In addition to these requirements, the dynamic reaction time of the mechanism to parameters must be short to avoid flooding of the relatively small buffers in the network. To meet these somewhat conflicting requirements, several policing mechanism have been proposed,

- Leaky Bucket mechanism
- Jumping Window Mechanism
- Triggered Jumping Window Mechanism
- Moving Window Mechanism

The leaky bucket mechanism is one of the typical bandwidth enforcement mechanisms used for ATM networks. This method can enforce the average bandwidth and the burst

factor of a traffic source.

The leaky bucket mechanism consists of a counter which is incremented by 1 each time a cell is generated by the source and decremented in fixed intervals as long as the counter value is positive. If the momentary cell arrival rate exceeds the decreamentted rate, the counter value starts to increase. It is assumed that the source has exceeded the admissible parameter range if the counter reaches a predefined limit, and suitable actions are taken on all subsequently generated cells until the counter has fallen below its limit again.

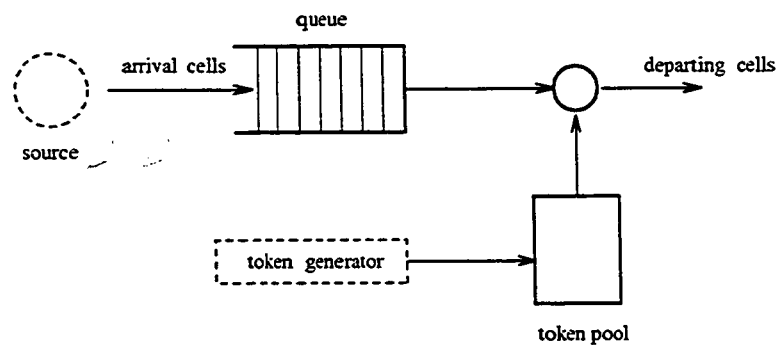

Figure 2.11: a queueing model for a leaky bucket method

The Jumping Window Mechanism limits the maximum number of cells accepted from a source within a fixed window to a maximum number N . The new window start immediately at the end of the preceding window and the associated counter is restarted again with an initial value of zero. Therefore, the window during which a specific cell is influencing the counter value varies from zero to the window width. The implementation complexity of this mechanism is comparable to the complexity of the Leaky Bucket mechanism. Counters are needed to measure the interval T and to count the number of arrivals, and variables are needed for the counter limit and the window width T .

In Jumping Window mechanism, the time window is not synchronized with source activity. To avoid the ambiguity problems arising from that fact, the Triggered Jumping Window mechanism has been proposed, where the time windows are not consecutive but are triggered by the first arriving cell. The implementation complexity for this mechanism is comparable to the complexity of the Jumping Window Mechanism.

The Moving Window Mechanism is similar to the Jumping Window mechanism, the maximum number of cell arrivals within a given interval T is limited by this mechanism. The difference is that each cell is remembered for exactly one window width. That is, the arrival time of each cell is stored and a counter is incremented by one for each interval.

Bibliography

- [1] J.P.Vorstermans and A.P.D.Vleeschouwer, "Layered ATM Systems and Architectural Concepts for Subscriber' Premises Networks", IEEE J.Select Areas Comm.vol.6, no.9, Dec. 1988
- [2] H.Ohnishi, T.Okada and K.Noguchi, "Flow Control Schemes and Delay tradeoff in ATM Networks", IEEE J.Select Areas Comm.vol.6, no.9, Dec. 1988
- [3] G.M.Woodruff and R.Kositpaiboon, "Multimedia traffic management principles for Guaranteed ATM Network performance", IEEE J.Select Areas Comm. vol.8, no.3 Apr. 1990
- [4] A.Hac and H.B.Mutlu, "Synchronous Optical Network and Broadband ISDN protocols", Computer, vol.22, no.11, pp.26-34, Nov. 1989
- [5] M.Wernik, O.AboulMagd and H.Gilbert, "Traffic management for B-ISDN Services" IEEE J.Network, Sept. 1992
- [6] N.Yamamaka, Y.Sato and K.Sato, "Performance Limitation of Leaky Bucket Algorithm for usage parameter control and bandwidth allocation methods" IEICE Trans. COMM. vol.E75-B, no.2, Feb. 1992

- [7] K.Sohraby, M.Sidi, " On the performance of Bursty and Modulated source subject to leaky bucket rate based access control schemes", IEEE Trans. Comm. vol.42, no.2/3/4, Feb/Mar./Apr. 1994
- [8] CCITT Study Group XVIII, " WP XVIII/8 – Report of meeting ", Temporary Document no.16, Geneva, Switzerland, June 1989
- [9] S.E.Minzer, " Broadband ISDN and Asynchronous Transfer Mode " IEEE Comm. Mag. vol.27 Sept. 1989
- [10] CCITT Study Group XVIII. Draft Recommendation, May 1990
- [11] T.Kamitake and T.Suda, " Evaluation of an admission control scheme for an ATM network considering fluctuations in cell loss rate " IEEE GLOBECOM '89, pp.49.4.1-49.4.7

Chapter 3

Call Acceptance and Traffic Policing in ATM/CDMA

CDMA and ATM have characteristics which separately and in combination can offer significant advantages in the cellular mobile radio and cordless office environments, especially when a wide range of service rates must be carried. Both allow a given transmission link to support a number of simultaneous virtual connections which can be used on demand and this can simplify routing and reduce overheads. With certain CDMA handoff techniques, the statistical multiplexing properties of ATM enable the most efficient use of the access network. In addition, mobile digital radio techniques, including CDMA, use burst mode transmission resulting in packetization delays. The process of filling ATM cells with speech also involves a packetization delay and the harmonization of mobile radio, and ATM standards result in systems, where the overall delay is less than the sum of the individual delays of the two packetization processes.

3.1 The Characteristics of Combined ATM and CDMA

Combined ATM and CDMA can offer certain advantages. The essential characteristics of the two techniques are outlined. CDMA allows many users to share the same radio frequency spectrum simultaneously through the use of spread spectrum. Each individual connection across the radio interface can be distinguished by the CDMA code allocated to that connection. Since there is a relatively large number of codes, they can be allocated to new connections as they are set up or when a mobile affiliates to a new base station. User data can then be transmitted over the air interface without the need for additional channel assignment. The CDMA code represents a virtual connection over the air interface.

Statistical multiplexing of user traffic occurs on the air interface itself as user data is generated and sent at essentially random times. When the system capacity is exceeded, the interference between users increases above a threshold resulting in excessive error rates. In a power controlled system, this can lead to instability, so traffic must be carefully managed.

For the most efficient use of the radio environment, a mobile must communicate through the base station which requires it to use the least transmission power. Any departure from this rule will reduce the capacity of the system.

ATM subdivides data for transmission into small fixed size packets called ATM cells. Unlike traditional transmission systems where network bandwidth is assigned even though a user has no data to send, ATM only uses network capacity when there is data to be transmitted. Traffic from different users is statistically multiplexed onto common high speed transmission systems. As the total traffic approaches the bandwidth of the transmission system, queues build up leading to delay. When buffers start overflowing, ATM cells are discarded and data is lost.

3.1.1 ATM characteristics

In general, a terminal will require a number of simultaneous connections, for example, a voice terminal will have signaling and speech connections and a multimedia terminal may have video and data connections as well. However, the number of simultaneous connections per mobile will be limited. Thus, although ATM connections could be identified by transmitting the ATM address, the overhead can be reduced by providing translation at the mobile and in the network between an air interface connection identity and the ATM address. Connection identity information can be removed altogether if each connection is carried on a separate CDMA code. An alternative would be to use one CDMA code per mobile, leading to all connections to a particular mobile being treated identically over the air interface.

Given that there are sufficient CDMA codes and the increase in complexity due to additional codes is marginal, one code per connection has been used in the system concept.

In addition to the ATM address, other ATM cell header fields can be removed over the air interface. the GFC field is only significant at the UNI where it is used to control access from a number of terminals. The header Error Control field is redundant, since the error detection and correction provided by digital radio system are generally more powerful. The HEC is also used for ATM cell delineation, which can be provided here by radio system framing. The payload Type (PT) and cell Loss Priority (CLP) fields will still have to be carried as they have network wide significance, but the payload overhead due to ATM is still reduced. At the receiving side of thee interfaces, the original ATM cell less GFC can be reconstructed and a default value inserted in the GFC field before a new HEC is calculated.

3.1.2 CDMA characteristics

CDMA systems operate best if every mobile communicates through its optimum base station. Thus, a mobile may be affiliated to a number of base stations and communicate via one or more depending upon the instantaneous radio conditions and the handoff regime imposed by the system.

A mobile may communicate through one of a number of base stations on a frame by frame basis. There will be no overall increases in traffic on the uplink, but the route taken by any one frame is indeterminate. Statistical multiplexing of the uplink information from a number of mobiles onto the access network link allows this characteristic to be exploited. ATM transmission is a good way of achieving this.

Unlike the present analog system and other digital systems, which divide the available spectrum into narrow channels and assign one or more conversations to each channel, CDMA is a wideband spread spectrum technology that "spreads" multiple conversations across a wide segment of the cellular broadcast spectrum.

Each telephone or data call is assigned a unique code that permits it to be distinguished from the multitude of calls simultaneously transmitted over the same broadcast spectrum. As long as the receiving device (in this case, the other phone) has the right code, it can pick its conversation out from all the others.

3.2 The Hybrid CDMA/ATM System Description

A variety of user terminals is foreseen, ranging from service specific to standard fixed network Narrowband Integrated Services Digital Networks (N-ISDN) and broadband terminals interfacing via special radio terminals. Fig.3.1 shows the system architecture. N-ISDN traffic is assumed to be transported in ATM cells. Terminals gain access using CDMA via the common air interface to base stations which are connected over a broadband access network to an internetwork (or a gateway).

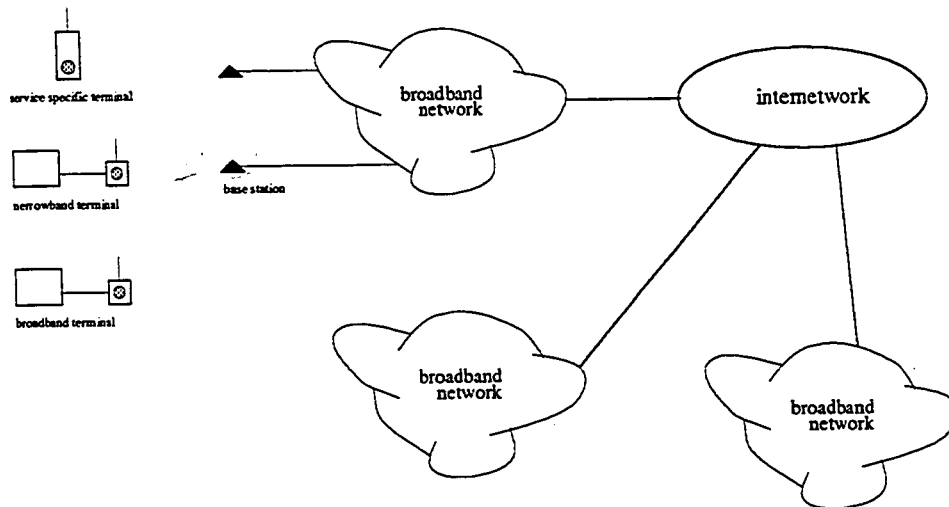

Figure 3.1: the system architecture

3.3 Simulation of Admission Rule and Cell Policing

In this work, we use a direct sequence/phase shift keying system (DS/PSK) as in recent trials[2], but we put emphasis on the call acceptance and congestion control aspects for a mixture of voice and data services. These issues have been explored in depth for terrestrial wideband networks, in particular those using the asynchronous transfer mode of operation (ATM) [5],[6],[7],[8] and we plan to use simplified versions of such call admission and cell policing techniques.

The third issue discussed here is the accommodation of VBR services in CDMA networks. Recent TIA standards[2] maintain that lower rate services are obtained by eliminating some cells generated by the user at the peak bit rate in his transmission to the base station (BS) or satellite. For transmissions from BS to the user, bits generated at peak rate are replicated at lower power to yield an average lower bit service. In this work we use a cell discard technique similar to TIA [2],[7],[8] for congestion control of VBR services. However, in our work and for one hop (e.g. from user to BS) networks, congestion control should be implemented at the user premises, i.e. before it develops at the radio channel where we care most about number of overlapping user cells. This number determines the probability of bit error, packet error (cell loss), total network throughput and call blocking which we evaluate under different traffic parameters and we investigate a variety of simple rules for combined (admission control/ congestion control) strategies.

3.3.1 The VBR-CDMA System

In a CDMA system, each user of a mixture of voice and data services (U_v voice users and U_d data users), employs a pseudorandom code of same chip rate ($\frac{1}{T_c}$) to spread his signal. The peak data rate of all users is assumed to be ($\frac{1}{T_b}$), and the ratio ($\frac{T_b}{T_c}$) is called

the spread spectrum processing gain (PG). Both data and voice users are assumed to be bursty with the burstiness ratio $\beta_{v,i}, \beta_{d,i}$ for the i -th voice and data user equal to the peak to average rate, i.e.

$$\beta_{v,i} = \frac{R^p}{R_{v,i}} \quad (3.1)$$

and

$$\beta_{d,i} = \frac{R^p}{R_{d,i}} \quad (3.2)$$

Stream (continuous) data users can be represented by a value $\beta_{v,i} = \beta_{d,i} = 1$, and in this work we assume the existence of 4 different average rates (1200, 2400, 4800, 9600 bps) corresponding to i values of (3, 2, 1, 0), with peak rate equal to 9600 bps.

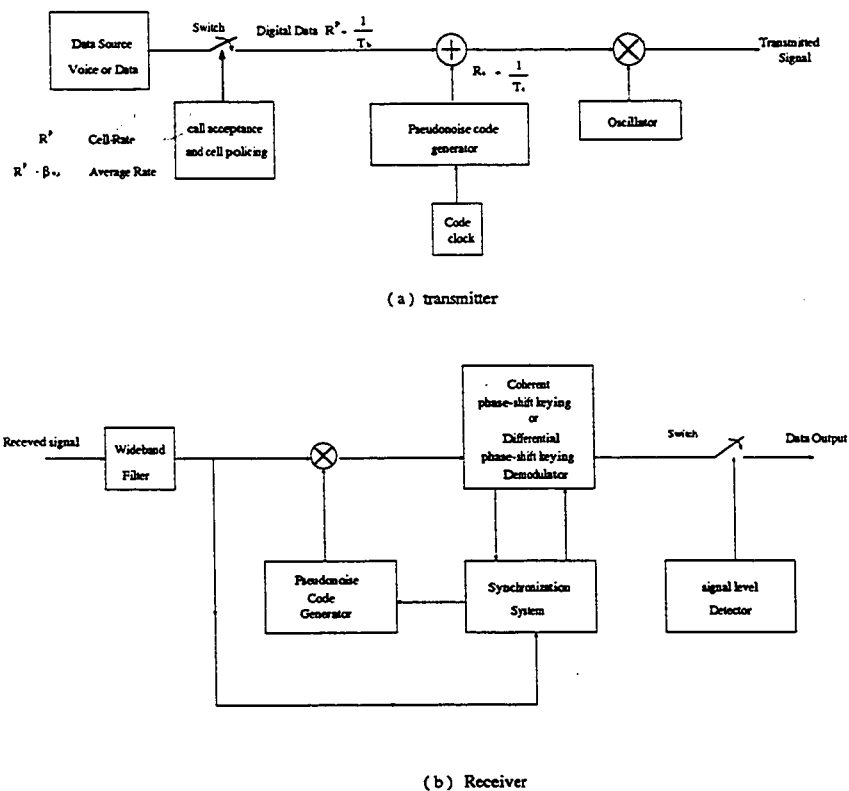
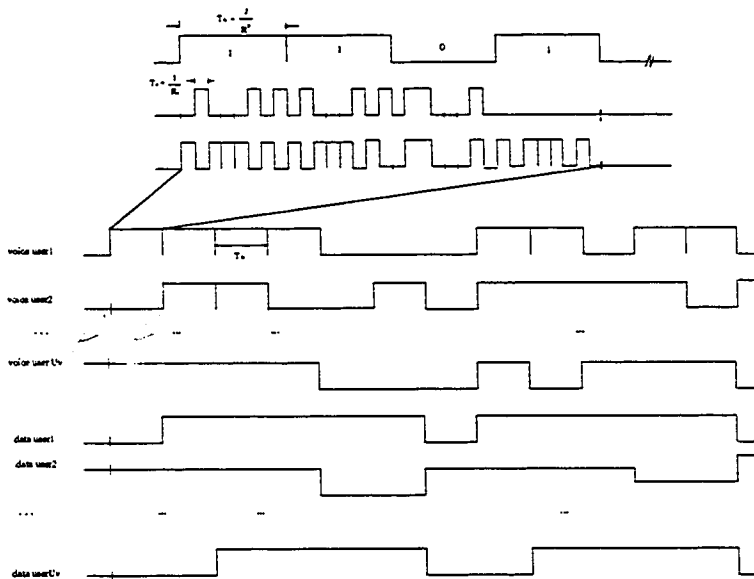

Figure 3.2: Direct sequence system with binary phase modulation

Fig.3.2 shows the transmitter and the receiver of a typical user. Data and spreading

code signals are modulo 2 added (to provide spreading) and the output signal modulates the carrier. The call admission and policing block controls the switch that feeds the information data bits to the modulation process. This switch is open whenever the user is completely idle or is in silence mode (for voice users), or whenever the average data rate agreed upon between the user and base station (BS) is violated (according to cell policing).



W = Measurement Window Length

Minimum power packet transmission during silent period not shown

Figure 3.3: Transmission Diagram without policing

During the user talk spurt and whenever the average user rate is within the agreed upon limit, data bits are dumped at full peak rate ($R^p = 9600bps$ in this work) Fig.3.3. This approach is similar to the one adopted recently by the standardization committees [2] and applies to the reverse link (from mobile user to BS). However, in the standard, during user silence periods packets with low power are transmitted to keep the user and the

station in synchronism. In our work, this later mode is not considered. On the other hand, in the forward link (from BS to mobile user), the standard maintains that the channel card at the BS assigned to a certain user will transmit lower data rate frames by repeating bits and transmitting them at lower gain levels. The switch in Fig.3.2a (corresponding to our system) does not exist in the VBR mode of the TIA standard[2] where transmission takes place continually, but at a reduced power level.

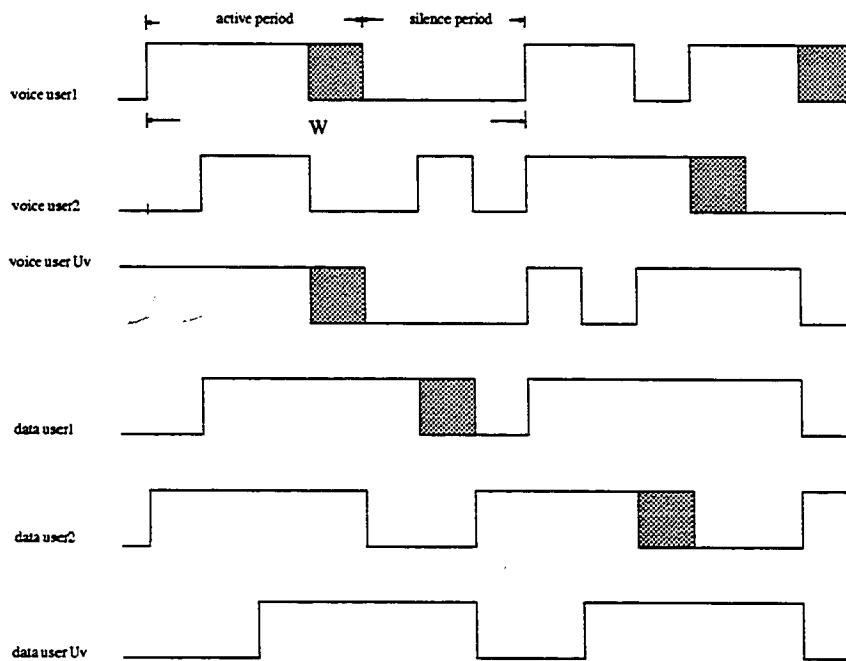

W= Measurement Window Size
Hatching represents cells eliminated due to violation of average bit rate agreement between user and station.

Figure 3.4: Transmission Diagram with cell policing

In the forward direction from BS or satellite to user, the transmitter must signal the destination that a certain specific packet is at a certain VBR. In this work, however, we investigate only the reverse link VBR scheme.

At the receiver Fig.3.2b, the received signal is despread, then data bits are detected. Accurate code and carrier synchronization is assumed. Forward error decoding could also be used, but is not shown in Fig.3.2. The results of this work only cover the synchronous unfaded reception case where data bits are aligned with chip edges and all users' signals are chip synchronous.

The receiver also measures the output bits energies to identify the silence gap in the received bit stream. To help keep the received code synchronization, the standard [2] states that the transmitter relays dummy data with low power during its idle periods. In this work, conditions of modulation, coding, fading, synchronization and idle period detection were assumed perfect (the interested reader may consult [3] for more on those spread spectrum modulation details.), and during the simulation, most of the attention was given to the effect of packet (-cell) errors on the call admission and packet truncation (congestion elimination) rules.

3.3.2 Modulation Aspects of the simulations

For convenience and completion purposes we introduce here the summary of the modulation-demodulation details of the multiaccess direct sequence phase shift keying signaling scheme (see, for example [3],[4]). The received signal at one of the voice or data users is given by,

$$r(t) = \sum_{i=1}^{U_v+U_d} \sqrt{2P_i} C_i(t + \tau_i) d_i(t + \tau_i) \cos(\omega_c(t + \tau_i) + \Theta_i) \quad (3.3)$$

where

$P_i = i^{th}$	user power
$d_i(t)$	information data bit of duration T_b
C_i	code chip signal generated by the user code of duration T_c
$PG = T_b/T_c$	processing gain of user signal
ω_c	carrier frequency
τ_i	random delay of user signal i
Θ_i	carrier phase of i^{th} signal
U_v and U_d	the active numbers of the voice/data users
$S_i(t)$	is an on-off signal that controls the cell elimination process, see Fig.3.4

At the receiver, this $S_i(t)$ is mixed with the local code signal and carrier (to yield $x(t)$ below), after which integration and dumping within the PSK demodulator Fig.3.4 yields the information data bits of a typical user (j th).

$$x_j(t) = \int_0^{T_b} \sum_{i=1}^{U_v+U_d} \sqrt{2P_i} C_j(t) C_i(t + \tau_i) d_i(t + \tau_i) \cos(\omega_c(t + \tau_i) + \Theta_i) \cos(\omega_c t + \Theta_j) dt \quad (3.4)$$

The received and local code signals are usually synchronized, such that,

$$\tau_i = \begin{cases} 0 & \text{if } i = j \\ f(0, T_b) & \text{if } i \neq j \end{cases} \text{ where,}$$

$f(0, T_b)$ is the uniform distribution function

Similarly,

$$\Theta_i = \begin{cases} \Theta_j & \text{if } i = j \\ f(0, 2\pi) & \text{if } i \neq j \end{cases} \text{ where,}$$

$f(0, 2\pi)$ is the uniform distribution function

The standard simplified analysis[3] that we employ our simulations, since congestion and flow control modulations are our objectives. assumes no FEC encoding, no fading, no multipath, perfect code, perfect bit and carrier synchronization. Moreover, the sum of all multiuser interferences is assumed to be modeled by an equivalent Additive White Gaussian Noise (AWGN) in which case the probability of bit demodulation error is given by [3],

$$P_b = \frac{1}{2} \text{erfc}(\sqrt{\text{SNR}}) \quad (3.5)$$

where,

$$\text{SNR} = \frac{1}{\frac{N_0}{2E_s} + \frac{U_v + U_d}{3 \cdot PG}} \quad (3.6)$$

It is also assumed that the signal detection level box in Fig.3.2b is operating under ideal conditions such that the receiver does not consider erroneous results of data bits detected during the user idle periods.

If the number of bits per data cell is L, the cell loss probability is given by,

$$P_L = 1 - (1 - P_b)^L \quad (3.7)$$

and the network throughput,

$$S_T = (1 - P_L) \cdot \rho \quad (3.8)$$

where ρ is the total normalized traffic utilization of all voice and data users.

3.3.3 ATM/CDMA Call Admission and Traffic Policing

For CDMA to be a variable multiaccess approach to integrate multimediuim services over a wide range of constant and variable bit rate server, it is important to come out with suitable admission and congestion control techniques. This is because in CDMA systems user's transmission overlap and large bit error probabilities would result its users violate their average bit rate agreements with satellite. Our work try to minimize the number of ATM/CDMA call overlap by proper admission control and congestion control techniques.

ATM cells are fixed size packets of 53 bytes each. Since calls are multiplexed on a cell level. ATM does not have rigid channel structures. New services can be readily adapted and old services dropped since bandwidth is allocated on demand. What favors ATM is the expected bursty nature of calls. Bursty calls generate traffic at high rates for short periods of time and traffic at much lower rates at other times. In ATM, bursty calls are statistically multiplexed. Each call is assigned some bandwidth that is lower than its peak bit rate.

This work's target is the call level and the ATM level. At the call level, new connection's call must be admitted to the network in a manner that protects the network performance of all existing connections, and the new connections must be withheld from portions of the network in a congested or nearly congested state. At the ATM level, cells must be ordered for processing by ATM concentrators and ATM switches, action must be taken to prevent an excessive cell flow on any given connection (cell policing herein), and in some cases it is appropriate to provide functions that help portions of the network recover from excessive cell flows.

At the call level, the most important congestion-related parameter is the **Call Blocking Probability**. At the ATM level, the most important congestion-related parameter is the **Lost Cell Ratio** or **Probability of cell loss**.

The traffic generated by a single user for a single service can be considered as either CBR (Constant Bit Rate) or VBR (Variable Bit Rate), in this work, four levels of VBR services in each of the data and voice categories were assumed.

1. CALL ADMISSION CONTROL

The purpose of admission control is to establish fair blocking probability and to ensure that the resources available to each admitted connection are sufficient to meet performance objectives for lost cell ratio.

Admission control is based on allocation of resources. When a new call arrives at an ATM network, the call is admitted as long as the network can support the expected traffic. Since ATM is packet-switched, the network does not explicitly reserve any bandwidth for calls. Instead, expected traffic is used as an indicator of the bandwidth required to support the new call to determine if the network can adequately support more calls. The following analysis shows that CDMA is an efficient method for this purpose.

In our simulations, quality i user's cells are generated according to binomially distributed variates with probability $\rho_{v,i}$ and $\rho_{d,i}$ for voice and data user populations respectively, i.e. the total probability of generating X_i, Y_i (voice, data) users in each priority level is given by,

$$P(\bar{X}, \bar{Y}) = \prod_{i=1}^4 \binom{U_{v,i}}{X_i} \rho_{v,i}^{X_i} (1 - \rho_{v,i})^{U_{v,i} - X_i} \binom{U_{d,i}}{Y_i} \rho_{d,i}^{Y_i} (1 - \rho_{d,i})^{U_{d,i} - Y_i} \quad (3.9)$$

where,

$U_{v,i}$ and $U_{d,i}$ are the total numbers of voice and data user having quality (i).

The total generation probability above of all voice and data users are obtained by multiplication of the four multinomial coefficients as in Eq.3.9 corresponding to the four ($i = 0, 1, 2, 3$) possible burstiness ratio. We notice that,

$$U_d \leq (X_1 + X_2 + X_3 + X_4)$$

where, U_d is the total number of accepted outstanding data calls. This is because of possible call blocking.

Similarly,

$$U_v \leq (Y_1 + Y_2 + Y_3 + Y_4)$$

as will follow shortly.

The base section receives the connection requests of data and voice users, via the signaling channel (inband or outband) and processes them (accept or reject) based on the call acceptance rule that will follow shortly. The number of accepted voice and data calls outstanding on the channel at any time is U_v, U_d respectively. In this work, we assume that a certain P_b (and hence P_b) criteria is to be satisfied, for example, a $P_b = 10^{-3}$ is found to be acceptable for most voice applications.

Based on a preset average bit criteria $P_b = 10^{-3}$ (for both voice and data), Eq.3.6 gives the allowable average load limit, the maximum number of users (voice and data) allowed at any time, i.e.

$$Z_L \cong 3 \cdot PG \cdot \left(\frac{1}{SNR} - \frac{N_0}{2E_s} \right) \quad (3.10)$$

where SNR value results from Eq.3.6 when inserting a value of $P_b = 10^{-3}$ at the L.H.S. of Eq.3.6.

Table 3-1. A Typical Instance of a Reservation Table
for CDMA Networks Supporting VBR Services.

call	type	average bit rate	burstiness ratio β_i
1	voice	4800	2
2	data	9600	1
3	data	1200	8
4	data	2400	4
5	voice	9600	1
6	voice	2400	4
7	voice	4800	2
...
C			

The call acceptance criteria for an arriving call now follows,

$$\begin{cases} \text{call accepted} & \text{if } (Z_{old} + 1) \leq Z_L \\ \text{call blocked} & \text{if } (Z_{old} + 1) > Z_L \end{cases} \quad (3.11)$$

where Z_{old} is the total number of current accepted voice and data calls.

$$Z_{old} = \sum_{j=1}^C h_j \quad (3.12)$$

and C is number of current active accepted calls.

Eq.3.11 assumes that all calls, voice and data, have the same peak and average rates which is not the necessarily case. For a multitude of voice/data classes we define a burstiness ratio β_i as,

$$\beta_i = \frac{\text{the average bit rate of the best quality class}}{\text{the average bit rate of the new call}} \quad (3.13)$$

In this work we have four class call qualities, which is class 0, class 1, class 2 and class 3, and $i = 0, 1, 2, 3$ denotes these four classes. From Tab.3.1 we can find that,

$$\beta_i = 2^i \quad (3.14)$$

Tab.3.1 shows a typical instance of the call reservation table. In the table, the fifth call is a voice user with burstiness ratio $\beta = 1$, this is a multiplexed voice user, a group voice users bindded with a multiplexor makes no silent period.

In multimediuim services, Z_{old} is not the total number of current accepted calls, and it becomes the total number of equivalent load consisting of lowest quality calls, which is,

$$Z_{old} = \sum_{j=1}^C \frac{2^3}{\beta_j} \quad (3.15)$$

therefore, the admission rule becomes,

$$\begin{cases} \text{call accepted} & \text{if } (Z_{old} + (2^3/\beta_i)) \leq Z_L \\ \text{call blocked} & \text{if } (Z_{old} + (2^3/\beta_i)) > Z_L \end{cases} \quad (3.16)$$

Since the case of using Eq.3.16 as a call admission rule implies that all voice and data call classes are all effectively replaced with an equivalent load consisting of lowest quality users, Eq.3.10 should use with an effective PG as following,

$$PG = \frac{T_b}{T_c} \cdot \beta_3 \quad (3.17)$$

For example, if the total available bandwidth is approximately equal to the chip rate,
i.e.

$$\frac{1}{T_c} \cong 1.229 \text{ MHz}$$

also the peak rate,

$$R_p = \frac{1}{T_b} = 9600 \text{ bps}$$

we then obtain,

$$PG \cong 1024 \quad (3.18)$$

Since thermal noise is negligible compared to the user interference in CDMA systems,
we assume a criteria of the CDMA service channel as,

$$P_b = 10^{-3}$$

$$\frac{2E_s}{N_0} = 100$$

substituting Eq.3.18 into Eq.3.10, we then have,

$$Z_L \cong 670 \text{ calls} \quad (3.19)$$

To check the application of the call admission rule of Eq.3.16, we assume that the voice load consists of 20, 20, 40, 10 users of qualities (priorities) 0, 1, 2, 3 respectively. Moreover, we assume that the data load is similar constituted. The effective lowest quality load replacing all the above (i.e. the number of outstanding calls) becomes,

$$Z_{old} = 2 \cdot (20 \cdot (2^3) + 20 \cdot (2^2) + 40 \cdot (2^1) + 10 \cdot (2^0)) = 660$$

the difference,

$$Z_L - Z_{old} = 670 - 660 = 10$$

for example, $i = 2$, class 2 user, from Eq.3.16 and $Z_L - Z_{old}$ we find that only 5 calls could be accepted. Further arriving calls are blocked.

While the call acceptance policy is based on average loads, the user instantaneous data rate varies (see Fig.3.3, Fig.3.4). This statement justifies the use of cell policing at the user ATM interface such that all user calls violating the average bit rate based on which the call was admitted are discarded and not transmitted to the base station or satellite.

In the Real Time Call Acceptance, an adjust parameter ξ has to be introduced,

$$\begin{cases} \text{call accepted} & \text{if } (Z_{old} + \xi \cdot (2^3/\beta_{i(j)})) \leq Z_L \\ \text{call blocked} & \text{if } (Z_{old} + \xi \cdot (2^3/\beta_{i(j)})) > Z_L \end{cases}$$

The introduction of the factor $\xi > 1$ exaggerates the average traffic, and it yields a higher call blocking probability. By adjusting the parameter ξ , we can operate the following cell policing function at an optimum area. Since the call acceptance policy is based on average loads, we need cell policing function to protect the network in the case which too many users operate at their peak rate simultaneously. By adjusting the parameter ξ .

we can change the traffic load that will be handled by cell policing function, and let the cell policing function work at an optimum area. We can see this in the simulation results.

Fig.3.5 shows the state diagram of the admission procedure employing the above rules. The probability of new call arrival is followed Poison distribution. When a new call coming, the call acceptance function checks the network stats and make decision to reject or accept this call according above rules. If the new call is accepted, the connection will be set up and data will be transmitted through the network until the connection released. If the new call is rejected, it will react follow Poison distribution.

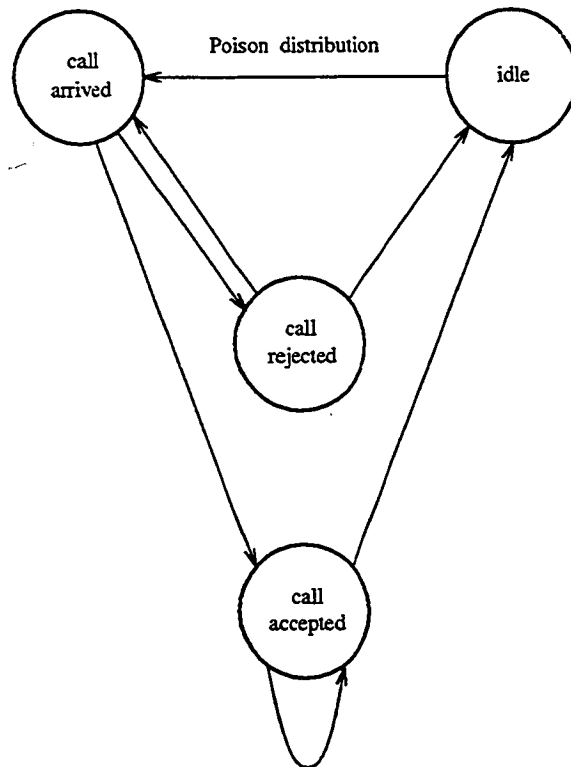

Figure 3.5: The state diagram of call acceptance

Fig.3.6 shows the flow chart of the complete admission procedure.

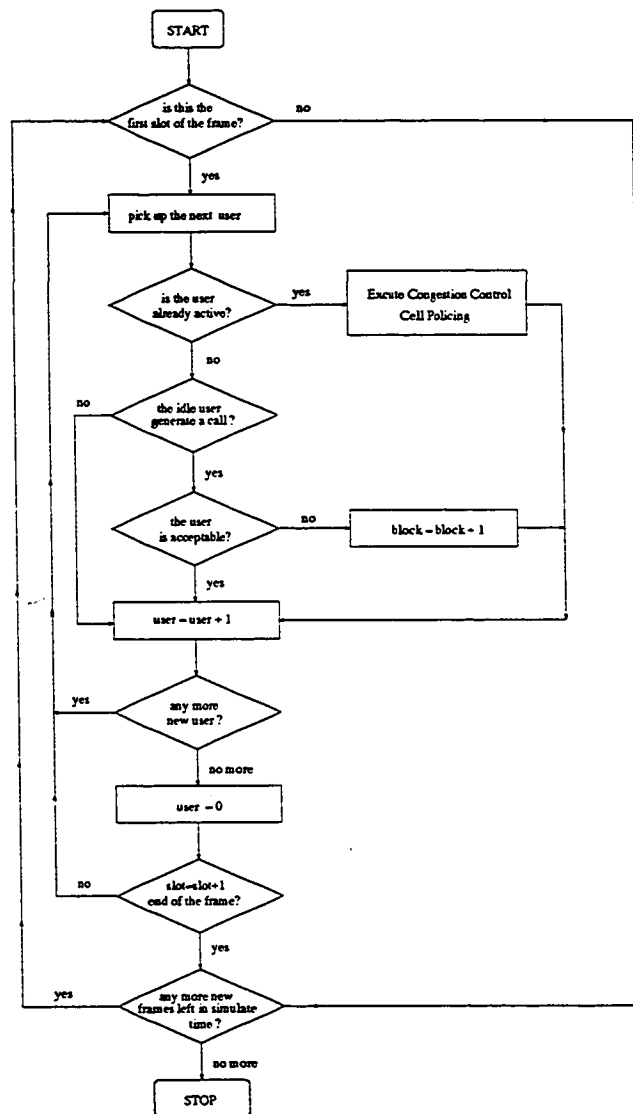

Figure 3.6: The flow chart of call admission control

2. CELL POLICING

The purpose of cell policing is to monitor a connection's resource usage for compliance with appropriate limits and to act on violations of those limits. In general, cell policing should be performed at the ATM level for each virtual circuit and for any traffic type. In this work, a virtual circuit is an ATM connection.

A simple periodic window technique is suggested for a user policing of his transmissions. Before introducing this technique, we first look at the call generation process of a bursty source (voice or data). A general n -state Markovian representation of an ATM source has been suggested[12] which could be used to approximate a wide range of traffic flow. Then $n = 2$ case is directed in Fig.3.7. The arrival process of new voice calls can be characterized by a Poisson process, and the distribution of the user's call durations can be characterized by exponential distribution. Within a call, talk spurts and silent periods alternate. During talk spurts, voice cells are generated periodically. During the silent period, no cell are generated.

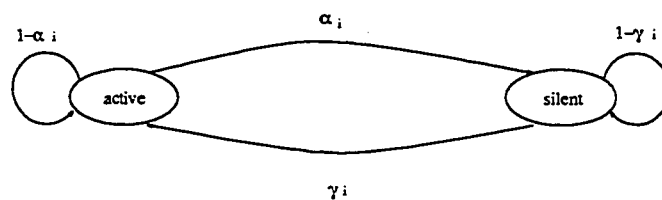

Figure 3.7: Cell generation process of a bursty source

Once the call is generated and accepted according to Eq.3.20, the user generates a cell with probability $(1 - \alpha_i)$ and does not generate with probability α_i during the cell time, when it is in the active state. In the silent state, the user turns to active state with probability γ_i , and stays in the silent state with probability $(1 - \gamma_i)$.

Assume $P_{A,i}$ and $P_{B,i}$ is the rate of entry the state A and state B,

$$\alpha_i \cdot P_{A,i} = \gamma_i \cdot P_{B,i} \quad (3.20)$$

now from

$$P_{A,i} + P_{B,i} = 1$$

we get,

$$P_{A,i} = \frac{\gamma_i}{\alpha_i + \gamma_i} \quad (3.21)$$

$$P_{B,i} = \frac{\alpha_i}{\alpha_i + \gamma_i} = 1 - P_{A,i} \quad (3.22)$$

The talk spurt $T_{A,i}$, and silence period $T_{B,i}$ are assumed geometrically distributed with parameters α_i and β_i , then,

$$T_{A,i} = C_s \cdot \sum_{k=1}^W (k-1) \cdot (1 - \alpha_i)^{k-1} \cdot \alpha_i \cong \frac{C_s}{\alpha_i} \quad (3.23)$$

$$T_{B,i} = C_s \cdot \sum_{k=1}^W (k-1) \cdot (1 - \gamma_i)^{k-1} \cdot \gamma_i \cong \frac{C_s}{\gamma_i} \quad (3.24)$$

where C_s is the cell size, and W is the congestion control window size in unit of cell. If L is the number of bits per data cell, then:

$$C_s = L \cdot T_b = \frac{L}{R_p} = T_p \quad (3.25)$$

In this work, the user monitors his own cell generation process over a window of W cells (see Fig.3.3, Fig.3.4) to make sure that his active and silence periods $T_{A,i}$, $T_{B,i}$ respectively are within the limits implied by his quality, i.e.

$$T_{A,i} = \frac{C_s \cdot W}{2^i} \quad (3.26)$$

$$T_{B,i} = (W - \frac{W}{2^i}) \cdot C_s \quad (3.27)$$

substituting Eq.3.25 into Eq.3.23 and Eq.3.24 enables one to find values of α_i , γ_i at a certain quality i ,

$$\alpha_i = \frac{2^i}{W} = \frac{\beta_i}{W} \quad (3.28)$$

$$\gamma_i = \frac{1}{(1 - \frac{1}{2^i}) \cdot W} = \frac{1}{(1 - \frac{1}{\beta_i}) \cdot W} \quad (3.29)$$

$$i = 1, 2, 3$$

Both voice and data sources could be bursty or stream and Eq.3.28 give α_i , β_i at a certain source quality i . For stream users,

$$i = 0 \quad \alpha_i = 1 \quad \gamma_i = 0$$

Due to the random generation nature of the bursty source in Fig.3.7, the actual talk burst length $\hat{T}_{A,i}$ may exceed its designated average value $T_{A,i}$, that is, when user cell policing (a measure of congestion control as in [7], [8]) comes into action, the cell discard is now controlled by the following equation,

during a certain window W , discard excess cells, if

$$\hat{T}_{A,i} > T_{A,i}$$

Fig.3.8 shows the state diagram of the cell policing function. We assume all the source are ON/OFF source. The standing calls in the network generate active burst followed the

interrupt Poison process. When an active burst generated, the ON/OFF source generates a cell according to binomially distribution. When a new cell is generated, cell policing function will check if the cell is a violating cell. Policing function will discard the violating cell, and the discarded cell will be ask resend.

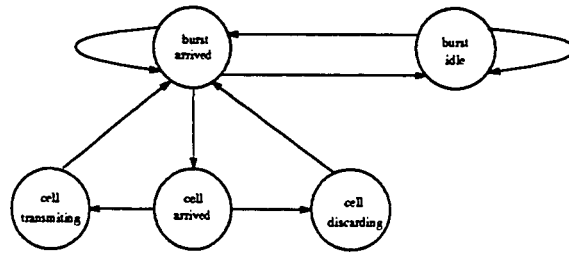

Figure 3.8: cell policing state diagram

Fig.3.9 shows the flow chart of cell policing function.

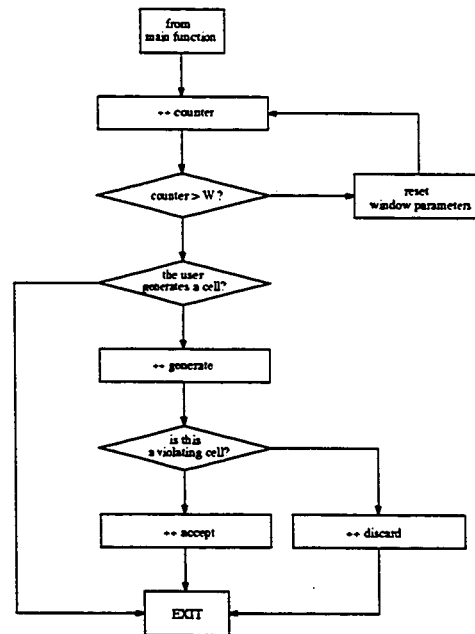

Figure 3.9: the flow chart of the cell poling at the user premisses

3.3.4 Simulation Results

In this work, we ran a simulation routine of a baseband CDMA/ATM network under different scenarios (different burstiness ratio, different P_b criteria) and for the four cases above of admission control and cell policing control. Carrier and code synchronization were assumed perfect, the chip synchronous case was simulated with no FEC or fading present. (to simplify the simulations)

In this simulation, we assume 3000 users in the network, and we assume only one call per user during the simulation time, the details is shown in Tab.3.2.

Table 3.2. The user's information

Q_i	number of users	traffic quantity	total traffic in the simulation time
8	200	1600	
4	400	1600	
2	800	1600	
1	1600	1600	$\rho_T = 6400$

Since we had only one call per user during the simulation time, we have,

$$Z_L \cdot \frac{N_{slot}}{C_{limit}} \geq \rho_T \quad (3.30)$$

where,

N_{slot} is the simulation time in unit of slot

C_{limit} is the call duration in unit of slot

we assume,

$$\begin{aligned} C_{limit} &= 4 \cdot W \cdot Q_i \\ N_{slot} &= N_f \cdot W \end{aligned} \quad (3.31)$$

where, N_f is the number of frames. then we get,

$$N_f \geq \frac{6400}{Z_L} \cdot 4 \cdot Q_i \quad (3.32)$$

From $P_b \leq 10^{-3}$, we found $Z_L \leq 670$. Now, we assume $Z_L = 400$, and then,

$$N_f \geq 64 \cdot Q_i \quad (3.33)$$

Eq.3.34 shows that, to find a reasonable simulation result, the simulation time has to be more than 512 frames. In our work, the simulation time is 1024 frames.

Since ATM cells are fixed size packet of 53 bytes each, we find the number of bits per data cell,

$$L = 53 \times 8 = 424 \text{ bits}$$

so that, the simulation parameters are obtained as following,

$$W = 64 \text{ slots}$$

$$L = 424 \text{ bits}$$

$$C_{limit} = 256 \cdot Q_i \text{ slots}$$

$$Z_L = 400 \text{ calls}$$

$$N_{slot} = 65536 \text{ slots}$$

$$N_{user} = 3000 \text{ users}$$

Users requesting a connection at a certain quality i is admitted or blocked according to the admission rule Eq.3.16, Eq.3.20, Fig.3.6 and Tab.3.1. Blocked calls are cleared, counted and averaged over all time and all users to give the average blocking probability. Users that have been admitted generate bursts according to the geometric distribution Eq.3.23, Eq.3.24 with α_i , γ_i obtained from Eq.3.28 and Eq.3.29. The discard variables for active users (see Fig.3.9) are averaged over all users during the simulation time to yield the cell discard probability.

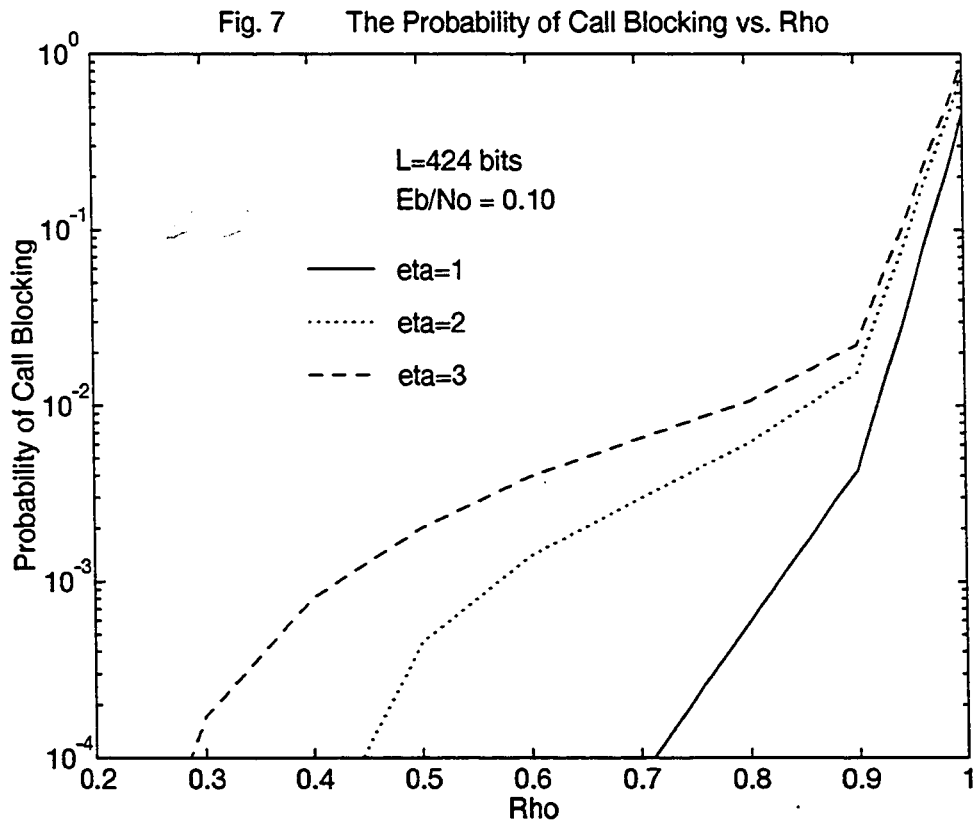

Figure 3.10: The probability of call blocking vs ρ

Fig.3.10 to Fig.3.22 show some of the simulation results obtained. These show that the ξ in Eq.3.18 is very important for admission control and congestion control. The error

probability in the channel, the blocking probability in the networks and the cell discard probability in the networks all depend on the ξ in Eq.3.20. there is an optimum value of ξ , this ξ could give us the best admission control and congestion control.

Fig.3.10 shows that increasing ξ of Eq.3.20 leads to a higher blocking probability, e.g. this rises from 10^{-4} to 10^{-2} at $\rho = 0.7$ when ξ does from 1 to 3.

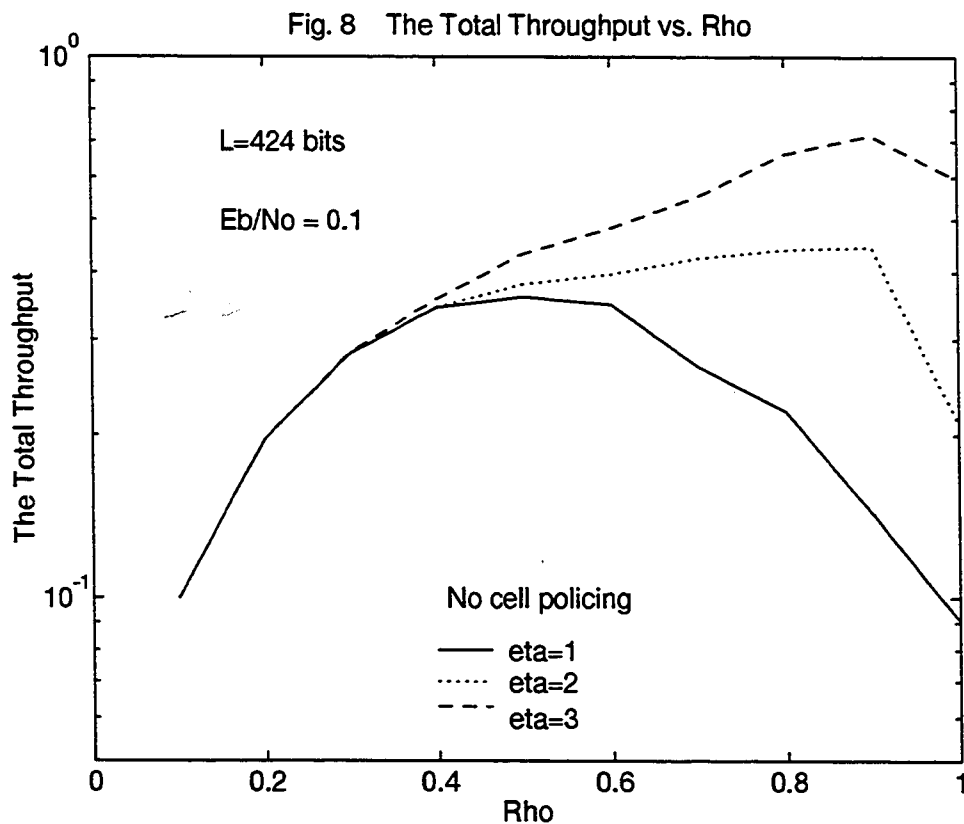

Figure 3.11: The total throughput vs. ρ

However, the same increase in ξ leads also to increasing the network throughput as in Fig.3.11. The conclusion we draw at this point is that we can admit more calls (less

blocking probability), but with a reduced network throughput (as expressed by the correct cell success probability on the channel).

from Fig.3.12 we can see that as ξ increases, the bit error probability decreases. This means we have to follow the limit implied by the error probability in the channel to decrease the blocking probability in the network.

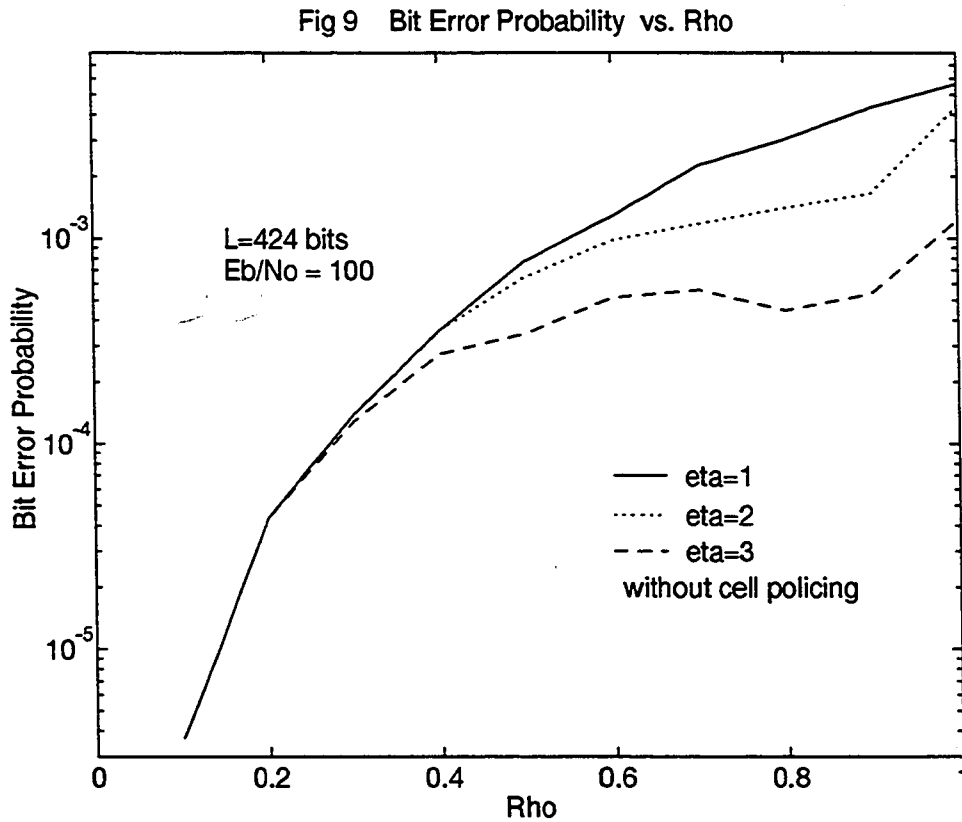

Figure 3.12: Bit error probability vs. ρ

These results show that there is an optimum value of ξ , with this ξ we could find the fair blocking probability to ensure that the resources available to each admitted user are sufficient. In this simulation, $\xi = 2$ come to be a good choice.

However, from Fig.3.10 and Fig.3.11, the better system throughput is at the cost of higher blocking probability, and even we chose $\xi = 2$, when $\rho > 0.9$ the throughput is not good. This implies that we need additional mechanism to prove the system throughput after the user's call setup.

The Congestion In The CDMA System

There is a threshold of number of users which the CDMA service channel can serve. If there are too many users in the CDMA service channel simultaneously, the successful sending probability will be too low and make the receivers can not extract data from the PN sequence successfully. The unsuccessful cells will be asked to resend and make the traffic more heavy, finally, will make the network deadlock. Our cell policing mechanism is to keep the CDMA service channel working in optimum by discarding violating cells, which is shown in Fig.3.13.

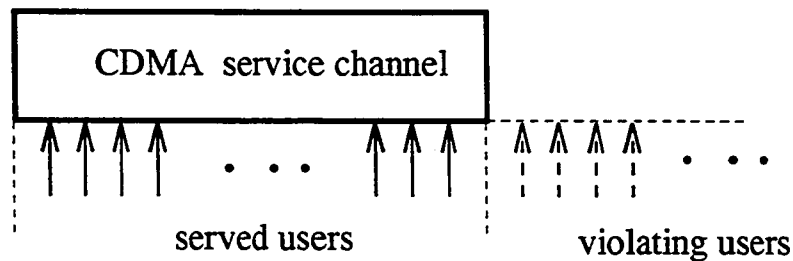

Figure 3.13: the congestion in CDMA system

If the number of users in the CDMA service channel is more than the threshold, we say there is the congestion in the network. In this work, we define the congestion duration as that the number of time slots which the congestion ever lasting. In other words, the congestion duration shows how long the congestion is in the network, and the probability of congestion duration shows how frequent this kind of congestion exists in the network.

Fig.3.14, Fig.3.15 and Fig.3.16 show that the probability of congestion duration increases as the traffic increases. This is the further proof that we need the cell policing mechanism after the connection established.

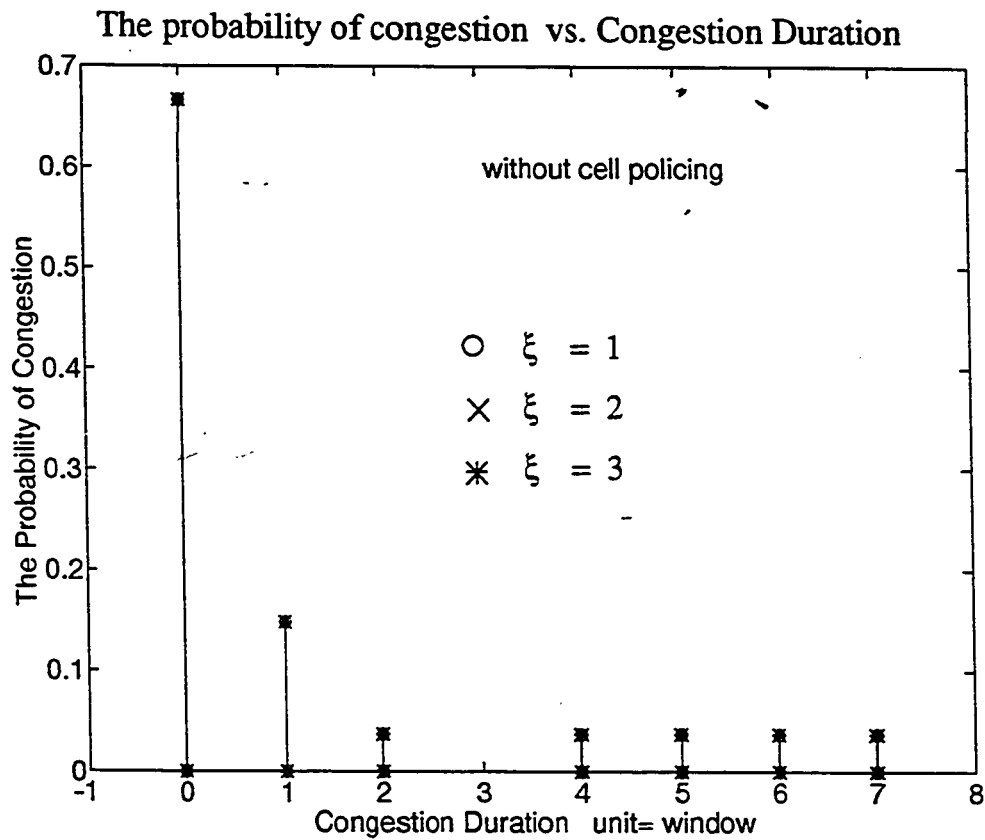

Figure 3.14: the probability of congestion duration at $\rho = 0.2$ no policing

Fig.3.14 shows the probability of congestion duration at low traffic (the traffic intensity $\rho = 0.2$) and without cell policing mechanism. It shows that the probability of no congestion equal to seventy percent, and the probability of the short congestion (which the congestion duration is less than one simulation window) is about twenty percent. The longest congestion duration is seven simulation windows, and thus, there is no dead lock

threaten. The long congestion duration (which the duration is more than one simulation window) exists at the probability of which is less than eight percent.

The probability of congestion vs. Congestion Duration

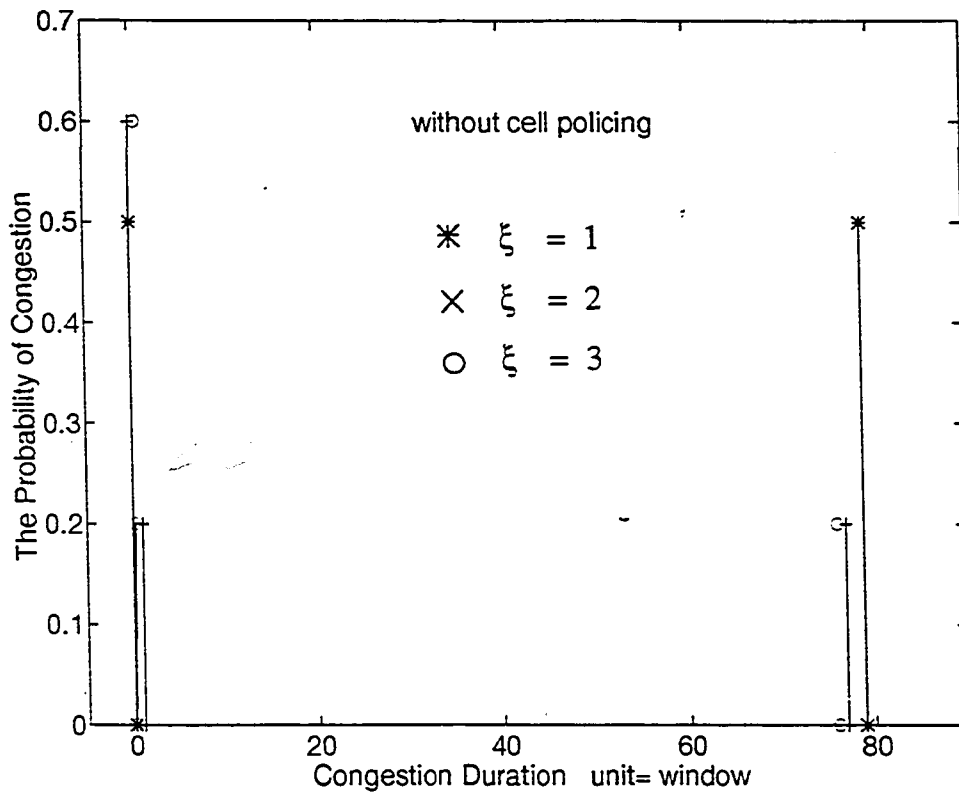

Figure 3.15: the probability of congestion duration at $\rho = 0.5$ no policing

Fig.3.15 shows the probability of congestion duration at the traffic intensity $\rho = 0.5$ without cell policing mechanism. The probability of no congestion goes down to sixty percent and there is almost no more short congestion. The longest congestion duration becomes eighty simulation windows, this means the dead lock threaten is shown up. The dead lock probability is more than fifty percent when the admission parameter $\xi = 1$, and the The dead lock probability is about twenty percent when $\xi > 1$.

When $\rho = 0.8$, Fig.3.16 shows that no congestion exists at the probability of fifty

percent and the longest congestion duration is eighty windows long, this implies that a dead lock will be shown, and the dead lock exists also at the probability of fifty percent during the simulation time. The user's call at this stage is most like connecting to a "swamp" network, all the standing calls in the network can survive by the probability of only fifty percent. This implies that we need congestion control following the calls admission.

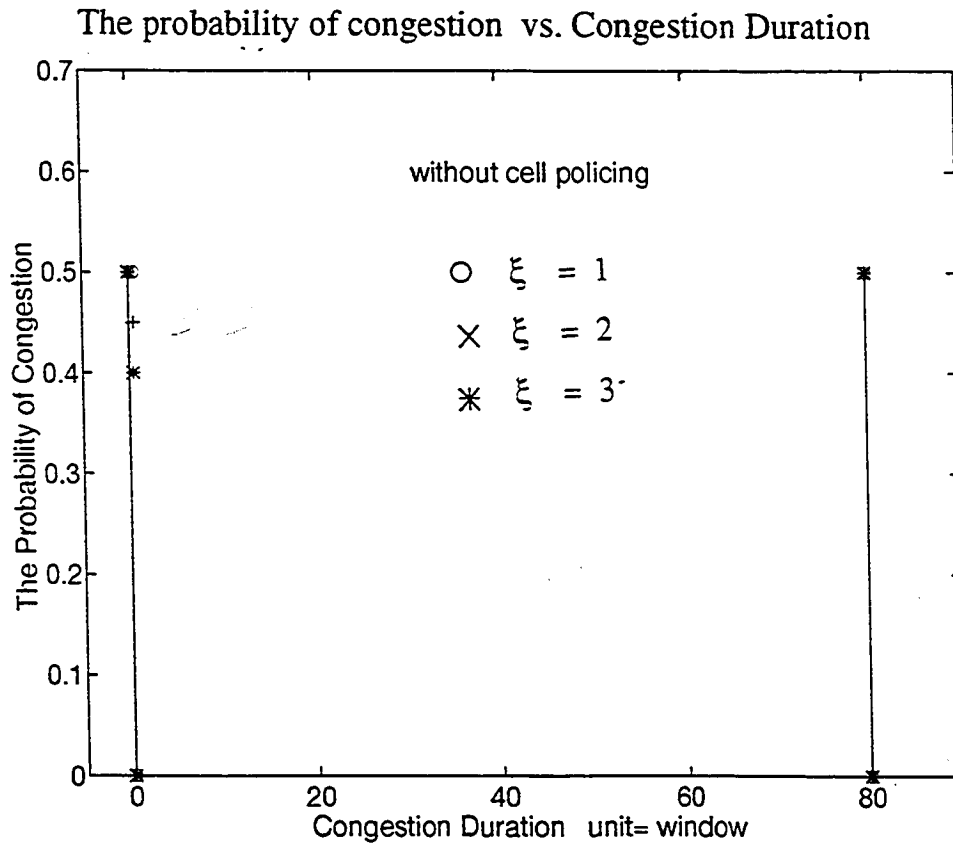

Figure 3.16: the probability of congestion duration at $\rho = 0.8$ no policing

Fig.3.17, Fig.3.18 and Fig.3.19 show that the cell policing is efficient compared to Fig.3.14, Fig.3.15 and Fig.3.16 which shows the case of no policing. Under the cell policing mechanism, the probability of congestion duration of the system is very low, there is almost

no congestion even at the very high traffic ($\rho = 0.8$). And there is no dead lock threaten at all (if the congestion duration is more than two third of the whole simulation time, we say it is the dead lock congestion).

The probability of congestion vs. Congestion Duration

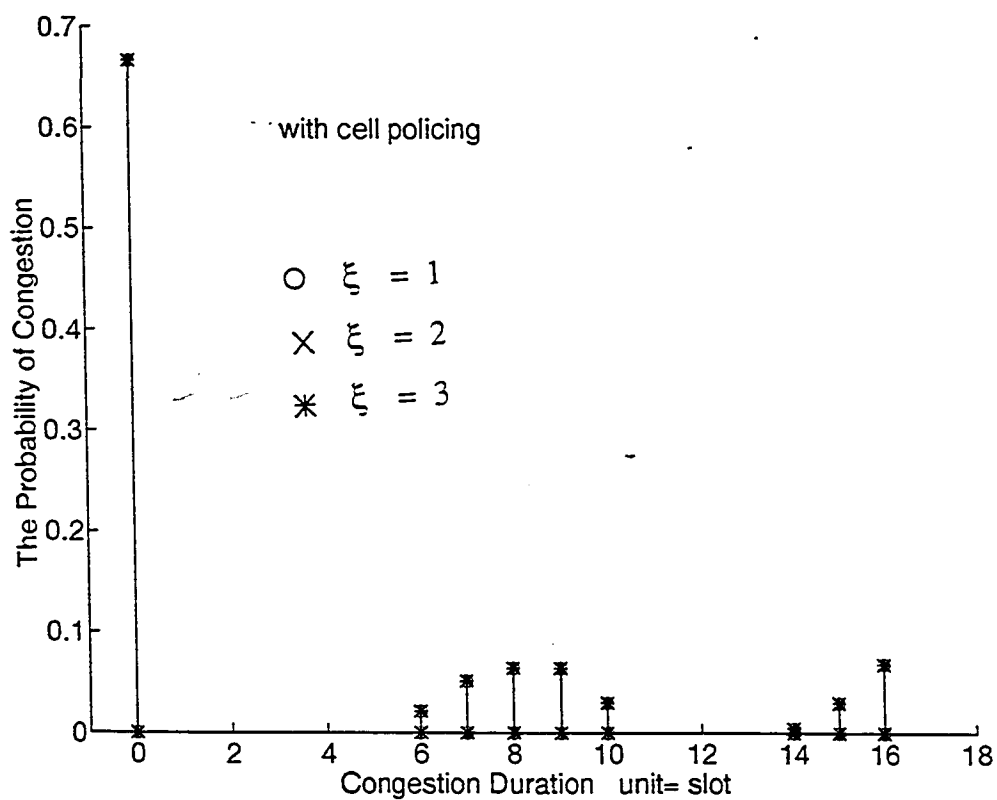

Figure 3.17: the probability of congestion duration at $\rho = 0.2$ with policing

Fig.3.17 shows the probability of congestion duration at the traffic intensity $\rho = 0.2$ with cell policing mechanism. The no congestion probability is almost seventy percent and the longest congest duration is only quarter of the simulation window (we defined the short congestion is which congestion duration is less than one simulation window). These very short congestions exist only at the probability of which is less than ten percent, compared

in Fig.3.14. the one window long congestion exists at probability of which is near twenty percent, and the longest congestion duration is seven windows. This shows the cell policing mechanism is very efficient.

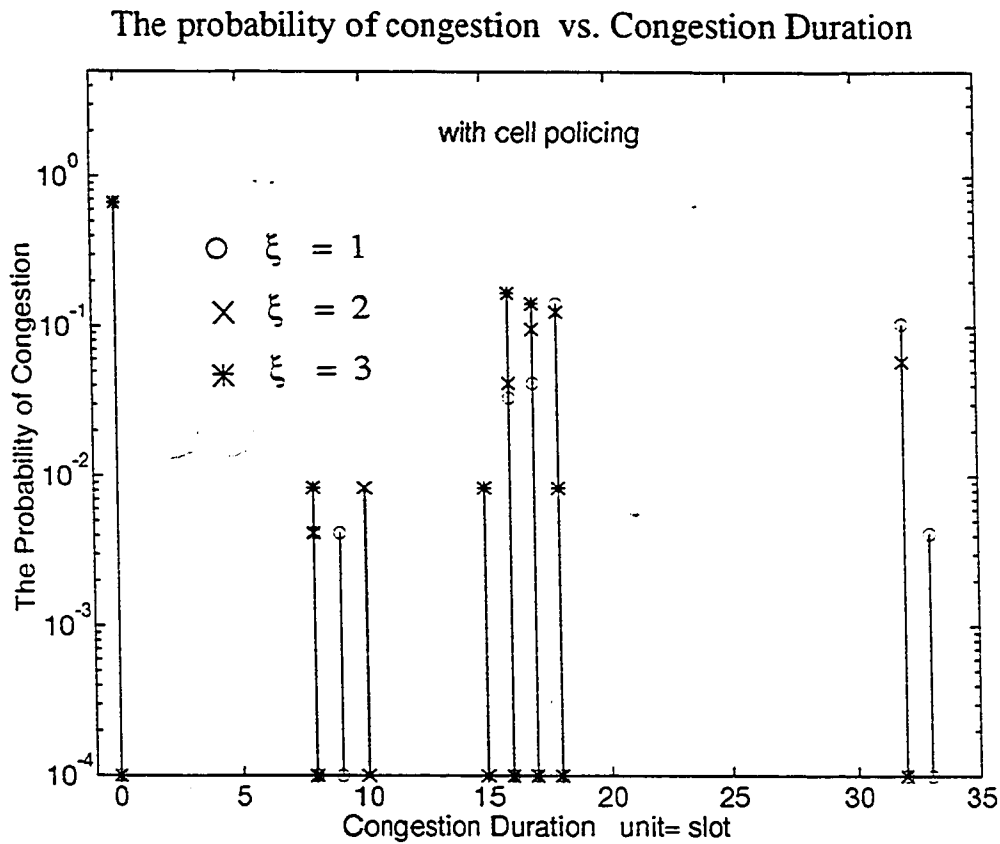

Figure 3.18: the probability of congestion duration at $\rho = 0.5$ with policing

Fig.3.18 shows the same function as shown in Fig.3.17. but at the traffic intensity $\rho = 0.5$. The probability of congestion duration increase clearly compared with Fig.3.17. However, they stay under twenty percent, and the longest congestion duration is less than half of the simulation window, in other words, they are very short congestion and rarely shown. And there is no dead lock threaten at all.

The admission control parameter $\xi = 1$ means that the admission control minimized the call blocking and $\xi = 3$ means that admission control maximizes the call blocking. In Fig.3.18, it also shows that the user's call which has the lowest call blocking probability has the longest congestion duration.

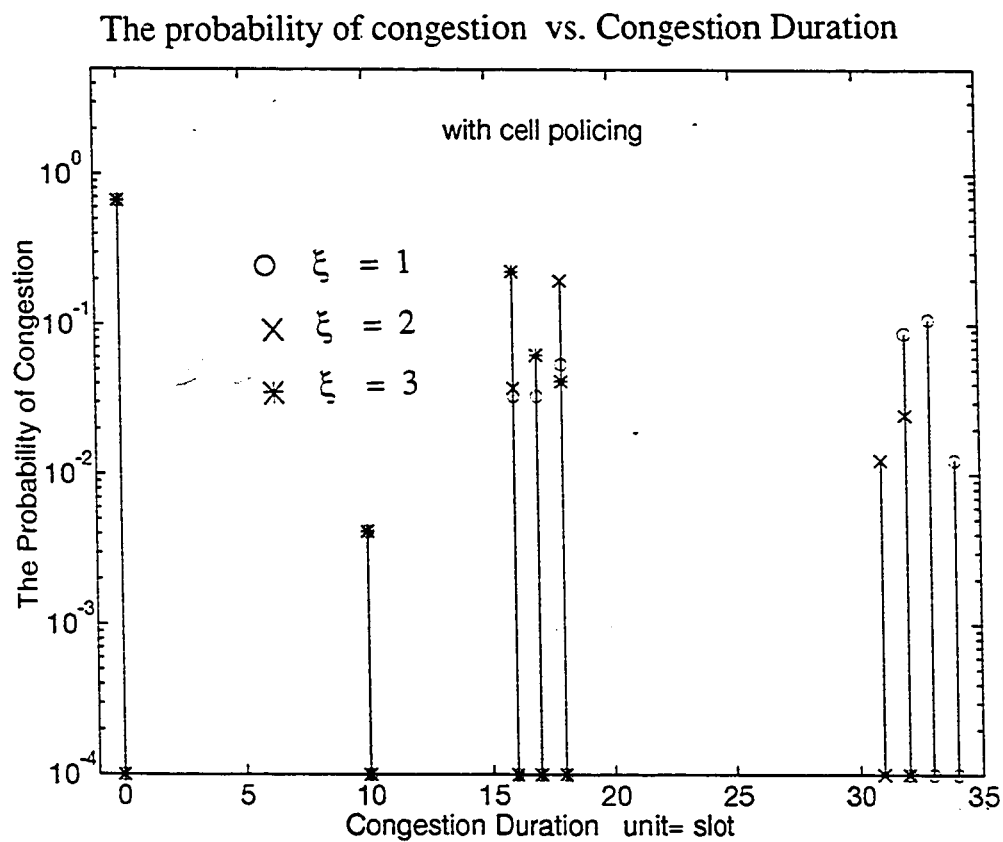

Figure 3.19: the probability of congestion duration at $\rho = 0.8$ with policing

Fig.3.19 shows the same function at the traffic intensity $\rho = 0.8$. The probability of congestion duration increases much more than at lower traffic (compared with Fig.3.17 and Fig.3.18). about thirty percent, however, it is still clear that the longest congestion duration is less than half simulation window. That is, under the congestion control, at

the high traffic the very short congestions appear more frequently than at lower traffic, and there are only the very short congestions under the congestion control mechanisms. These very short congestions do not affect the networks very much, this implies that the congestion control is efficient and necessary.

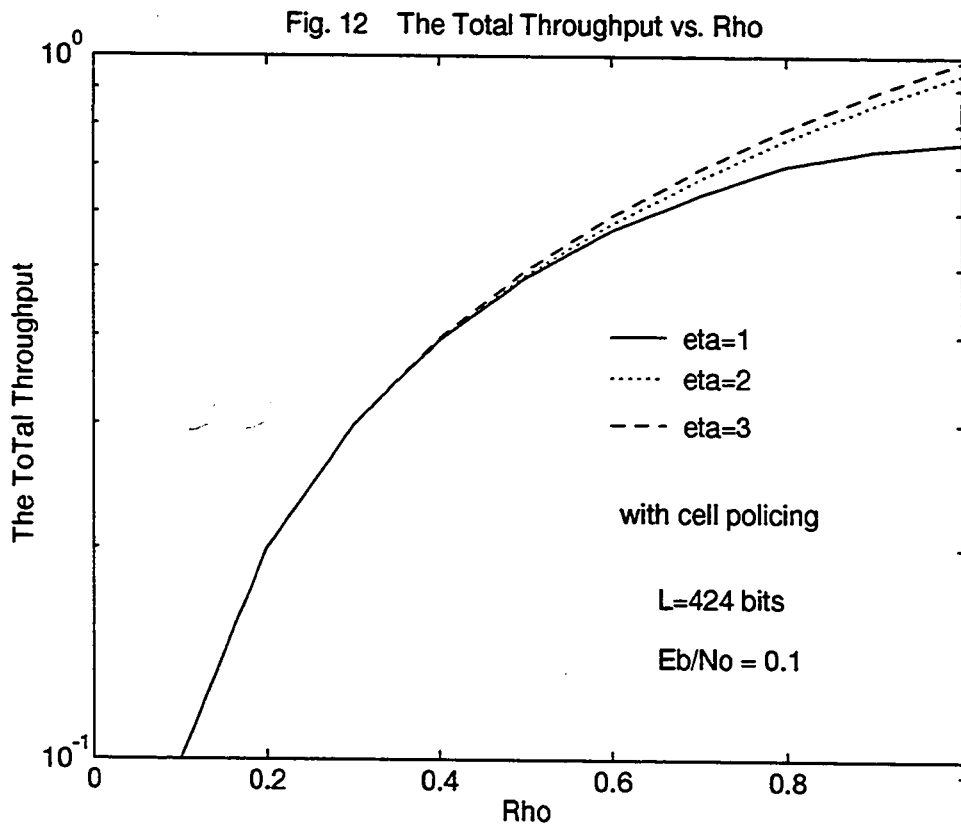

Figure 3.20: the total throughput vs. ρ

Fig.3.20 shows the total system throughput as a function of traffic intensity ρ under congestion control mechanism. It is clear that at the lower traffic values area, the total throughput values obtained are not depended on the admission parameter ξ . This allow us to get the maximum system throughput with the minimum blocking probability. After $\xi > 0.5$, it shows that higher call blocking could get higher system throughput, and

the system throughput is in direct proportion to the traffic intensity ρ , compared with Fig.3.11, we can see that the congestion control mechanism works well.

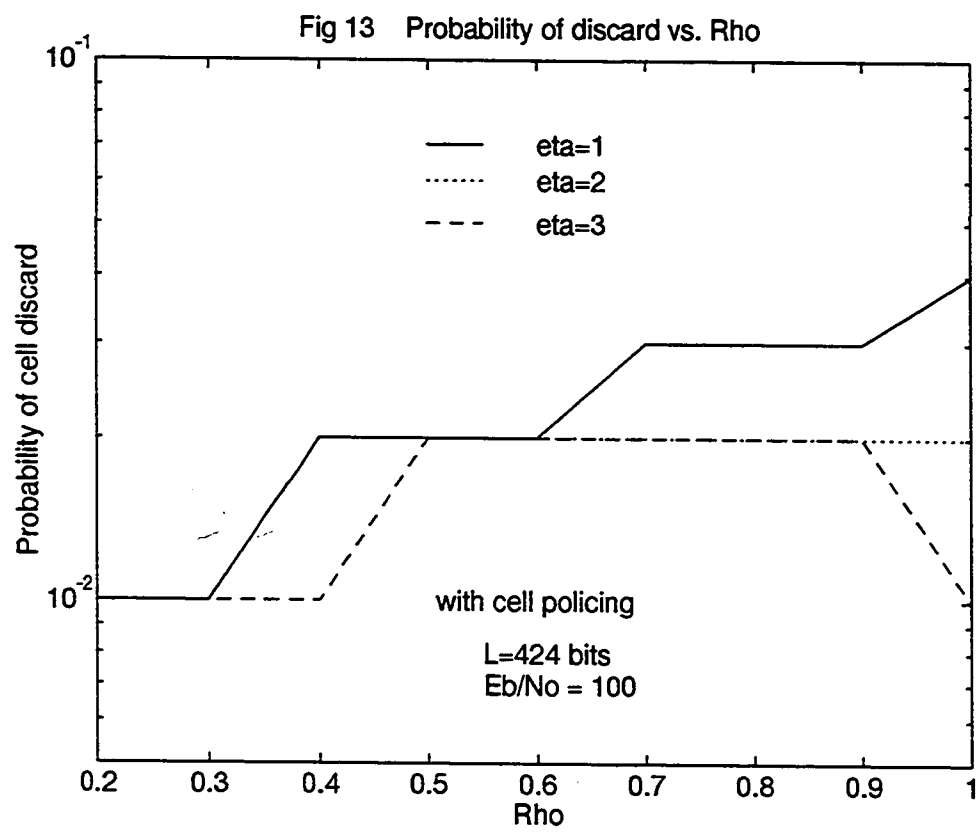

Figure 3.21: the probability of discarding vs. ρ

However, as in Fig.3.21 shows that the lower the blocking probability, the higher the probability of cell loss (due to discard by the policing function). This means that we encounter minimum blocking probability at the cost of higher cell loss probability. That is, if we allow more user admission($\xi = 1$), we should be able to tolerate more cell losses in congestion control. It is necessary to choose an optimum situation.

Fig.3.22 shows that the lower the blocking probability, the higher the bit error probability in the channel. After $\rho > 0.6$, from Fig.3.22, we find that the ξ affects the bit error probability in the channel much more than before. This implies that to keep a good condition in the channel, we have to choose a suitable blocking probability.

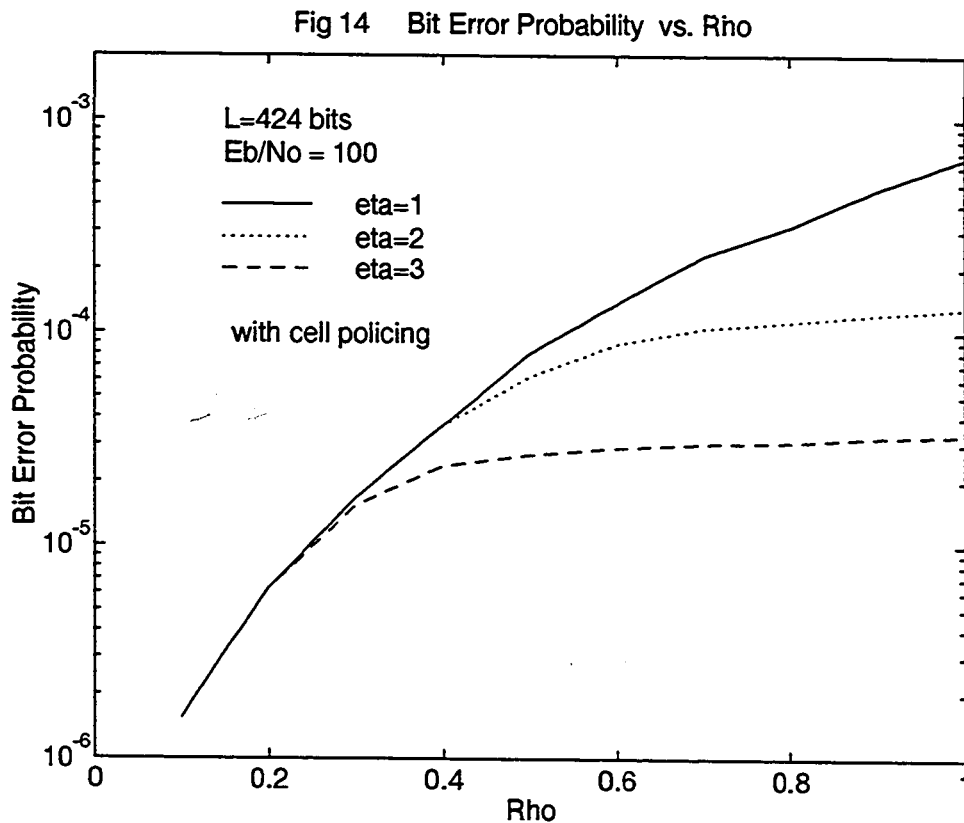

Figure 3.22: the bit error probability vs. ρ

In general, admission control and congestion control are two necessary and separate parts of the network traffic control. However, in this work, they were conveniently coupled to reach a compromise, we need to adjust ξ to get a fair blocking probability, and we could adjust only one parameter ξ to meet the optimum traffic control. This shows that CDMA is an efficient way for ATM oriented network traffic control.

Bibliography

- [1] A.K.Elhakeem, D.L.Schilling, W.P.Baier and M.Nakagawa editors " Code Division Multiple Access Networks " IEEE Journal of Selected Areas in Comm., May and June issues, 1994.
- [2] TIA, " An Overview of the Application of Code Division Multiple Access to Digital Cellular Systems and Personal Cellular Networks " TIA.TR45.5, Subcommittee, Report, March, 1992
- [3] D.A.Torieri, " Principles of Secure Communications Systems " 2nd Edition, Artech House, 1992
- [4] E.Geraniotis, M.B.Pursley, " Error Probability for Direct Sequence Spread Spectrum Multiple Access Communications - Part II. Approximations ", IEEE Trans. on Com. Vol. COM-30, No. 5, May 1982
- [5] J.J.Bae, and T.Suda, " Survey of traffic Control Schemes and Protocols in ATM Networks " IEEE Proceedings, Vol.79, No.2, Feb. 1991. pp. 170-189
- [6] A.K.Elhakeem, H.Mouftah, Jayant Maghee, Lian Yee, " Analysis of New Quality Admission/Congestion Policy for an ATM based ISDN ", IEICE Trans. An. Comm., Japan, Nde75-B, No.3, Npareh 1992, pp.193-206

- [7] I.W.Habib and T.W.Saadawi, " Controlling Flow and Avoiding Congestion in Broadband Networks " IEEE Comm. Magazine, Special Issue, Vol.29, No.10, Oct. 1991, pp.46-53
- [8] B. Dasbi and V.Sabsena, " Resource Management and Congestion Control " IEEE Comm. Magazine, Vol.4, No.3, May 1990, pp.8-35
- [9] C.Anthony Cooper, Kun I.Park "Toward a Broadband Congestion Control Strategy " IEEE Network Magazine, May 1990
- [10] Duke Hong, Tatsuya Suda, " Congestion Control and Prevention in ATM Networks " IEEE Network Magazine, July 1991
- [11] W.B.Yang and E.Geraniotis, " Admission Policies for integrated voice and data traffic in CDMA packet radio networks", IEEE J.Select Areas Comm., vol.12, no.4 May 1994
- [12] V.Ramaswami and G.Latouche, " Modeling packet arrivals from asynchronous input lines ", 12th Int. Teletraffic Congr., Toronto, Italy, June 1988 pp4.1A.5.1-4.1A.5.7

Chapter 4

Traffic Shaping in Hybrid ATM/CDMA/TDMA system

For CDMA to be a variable multiaccess approach to integrate multimedia services over a wide range of constant and variable bit rate services, it is important to come out with suitable admission and congestion control techniques. This is because in CDMA systems user's transmission overlap and large bit error probabilities would result that users violate their average bit rate agreements with satellite. Our work try to minimize the number of ATM/CDMA call overlap by proper admission control and congestion control techniques.

By our hybrid ATM/CDMA/TDMA system, many bit rates are accommodated by the division of time frame into four subframes, one for each service, and allow VBR users of each service to access only the subframe on overlap bases. However, in TDMA system the same work results a large number of slots per frame, a more complexed slot assignment schemes and more on board satellite processing. Unlike TDMA system, in CDMA system, we do not have slot assignment, the TDMA wasted slots will be minimized in CDMA system during speech idle time. Management of four subframes is much easier than management of

hundreds of TDMA slots. In CDMA system, the on board processing is simply to estimate the error probability and to set the congestion indicator.

4.1 Introduction

The modern workplace requires data communications between a variety of data processing equipment. Such interconnections are achieved through local area networks. To provide portability to the terminals and to avoid installation and relocations costs, a wireless LAN is a possible solution. One such wireless LAN is based on direct sequence spread spectrum techniques.

Direct Sequence Code Division Multiple Access (DS/CDMA) networks [1][2] have gained momentum recently due to such characteristics as multipath fading resistance, some inherent security, low power cost per station, inherent voice silence utilization, automatic cellular frequency reuse, etc.

On the performance evaluation side, the literature is rich with signal to noise ratio comparisons between CDMA and non CDMA networks. On the data transmission side, some CDMA queuing models have been analyzed [3], either without evaluating the exact bit or cell error probability in the various fading environments, or these probabilities were evaluated without attention to the networking aspects such as traffic characterization, buffering, etc.

In this work, we simulate a hybrid ATM/TDMA/CDMA satellite network for video, voice and data users' transmission over three kind of multipath fading channel. In the simulations, we introduce congestion control using leaky bucket and virtual leaky bucket schemes. To compare the leaky bucket and the virtual leaky bucket schemes, we calculate

the system delay, the cell discarding probability and the networks congestion probabilities. We also evaluate the bandwidth efficiency. To improve the bandwidth efficiency, we introduce the flow control scheme.

To avoid overloading the time slots of each subframe by many overlapped transmission (allowable by CDMA concept), traffic is measured at the satellite and congestion indicators are relayed by the satellite in its down link transmissions. Different ground users — these tones in congestion with modified — of the virtual leaky bucket congestion control schemes.

In the following, we show the cost efficiencies of the — modulation, access and congestion control schemes.

4.2 System Description

Direct sequence spread spectrum (DSSS) with its inherent resistance to multipath is a promising technique for wireless communication networks. To allow multiple users within a limited bandwidth, code division multiple access (CDMA) is needed.

To start with we briefly outline the satellite DS modulation concepts used in this work. The bandwidth efficiency (or the bandwidth utilization) in fading multipath channels is very important for the DSSS communications. Coding and diversity combining can improve the bandwidth efficiency of DSSS communications. Another method for improving the bandwidth efficiency is the use of $M - array$ signaling.

The bandwidth efficiency η can be defined as [1]

$$\eta = \frac{KR_b}{W} \quad (4.1)$$

where R_b is the user peak bit rate, W is the bandwidth of the channel, K is the number of users.

For M -array orthogonal signaling, if the CDMA code length is N , then,

$$\eta = \frac{K \log_2 M}{N} \quad (4.2)$$

In our simulation, we adopt a direct sequence spread spectrum CDMA communication system which assigns a set of M -orthogonal sequences to each user as in [6]. This system is similar to the classical DSSS-CDMA model. However, in the classical DSSS-CDMA model, K users share a channel by phase modulating their transmissions with signature sequence. These users make no attempt at time synchronization and they all transmit at the same frequency. The users use a pair of antipodal sequences and transmit 1 bit per sequence. In our system, we simulated the K users transmit $\log_2 M$ bits of information per sequence. This is different than the classical DSSS-CDMA model. This system provides spread spectrum capability and trades increased bandwidth efficiency for increased signal complexity. This system is particularly well suited for radio systems using the lower end of the frequency spectrum and the medium frequency band. At these frequencies, bandwidth is scarce, but increased processing time is available and so complicated signal designs may be considered.

the k^{th} user is assigned the complex code set, $V^{(k)}$, where,

$$V^{(k)} = (V_1^{(k)}, V_2^{(k)}, \dots, V_M^{(k)}) \quad (4.3)$$

and,

$$V_{\mu}^{(k)} = (V_{\mu,0}^{(k)}, V_{\mu,1}^{(k)}, \dots, V_{\mu,N-1}^{(k)}) \quad (4.4)$$

where N is the length of one M -orthogonal sequence.

$$V_{\mu,n}^{(k)} = \exp(j\theta_{\mu,n}^{(k)}) \quad (4.5)$$

$V_{\mu,n}^{(k)}$ is a complex r^{th} root of unity. This means each signature sequence is r -valued and an r -phase modulation is used. There is no specific relationship between r and M , for the low band, r can be as large as 32, for the satellite band r could be 2 or 4. The use of r -phase modulation produces no average performance improvement over biphasic modulation when a linear receiver is used. However, interfering biphasic signals interact in non linearities to produce "dead zone" or "capture effects" [14], where r -phase signals exhibit such effects to a much smaller degree.

If M -array equally likely data symbols are transmitted at a rate of one every T seconds, the signal transmitted by the k th user in order to send the μ th symbol during the the time interval $[0, T)$ is,

$$S(V_{\mu}^{(k)}, t) = \text{Re} \left[\sqrt{2P_s} \sum_{n=0}^{N-1} [V_{\mu,n}^{(k)}]^* \Gamma(t - nT_c) \exp(j\omega_c t + \theta_k) \right] \quad (4.6)$$

where,

- P_s is the average signal power.
- $T_c = \frac{T}{N}$ is the chip duration.
- $\Gamma(t)$ is the chip waveform.
- θ_k is the carrier phase.
- $\omega_c = \frac{2n\pi}{T_c}$ is the carrier frequency common to all users.

The chip waveform satisfies $\Gamma(t) = 0$ for $t < 0$ and for $t > T_c$. Beyond these constraints, $\Gamma(t)$ may be selected to give the best possible combinations of multiple access capability and spectrum shaping. Typically, $\Gamma(t)$ is a rectangle, half sine or raised

cosine with duration T_c . However, it may have duration less than T_c if duty cycles less than unity are desired. In any event, the chip waveform is normalized.

Fig.4.1 shows the transmitter block diagram of the DS/CDMA system with M -orthogonal coding. Each user picks one codeword out of M possible orthogonal codes depending on his data symbol (consists of $\log_2 M$ information bits). If the number of users is less than M , the probability of these 2 users overlap in same code is very small. (even when the data symbol are the same) However, if the number of users is more than M , the identity of data symbols plays a major rule which reflects itself in the bit error evaluation. Since the users can use same code word if they have the same symbol.

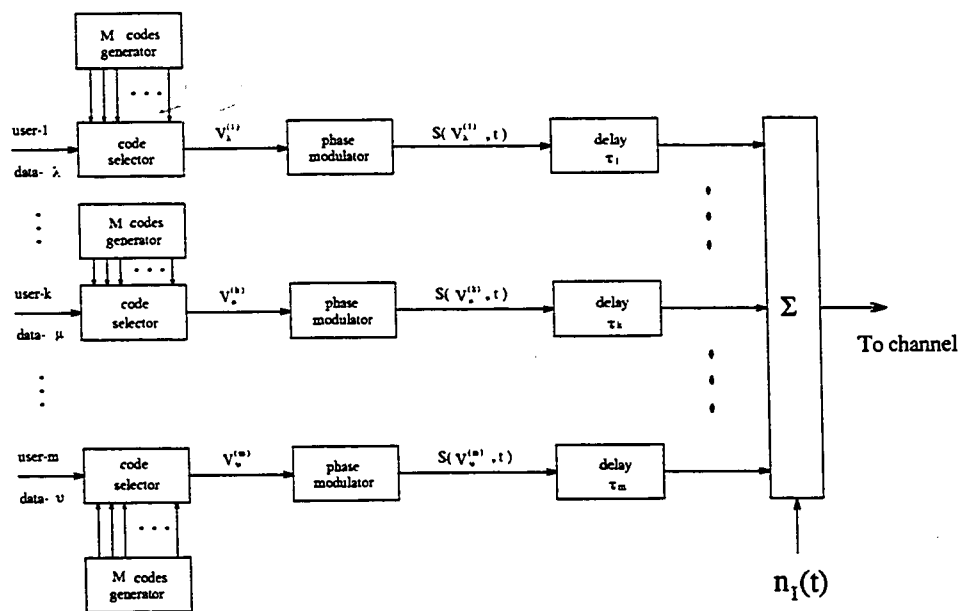

Figure 4.1: A DSSS-CDMA transmitter system with M -orthogonal codes

From Fig.4.1, the signal from the k th user suffers a delay of τ_k . The input to the receiver is thus the sum of the various delayed signals of various overlapped users transmission together with the atmospheric and thermal noise process $n_I(t)$.

The number of subscribers is typically much larger than the number of orthogonal codes. Similar to the standard TIA and QUALCOMM approach, the few existing orthogonal codes are assigned to users on demand once the call is accepted by the satellite. However, each user's code are shared by all users in the cell. Now selective identification is guaranteed by the longer user code, and the minimum level of cross user interference is also guaranteed by use of the short orthogonal codes, i.e. finally we can say that the number of orthogonal codes sets the calling on the number of active codes at any time. On the other hand, the number of subscribers is handled by only the longer user code.

To combat the multipath distortion and achieve better performance, diversity combining is needed. A matched filter receiver structure takes the advantage of the implicit diversity of the receiver signal.

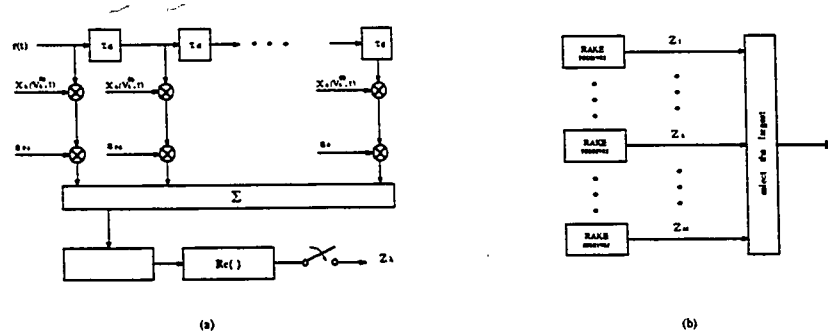

Figure 4.2: A RAKE receiver.

The optimum receiver for wideband fading multipath signals is the RAKE matched filter [4]. This receiver takes advantage of the implicit diversity of the multipaths in the received signal. In our simulation, we use the coherent RAKE matched filter with maximal ratio combining structure as shown in Fig.4.2. Fig.4.2(a) shows a RAKE receiver with maximal ration combining for the k^{th} user and the λ^{th} symbol. Fig.4.2(b) is the receiver block diagram of the DSSS-CDMA with M -orthogonal code system.

4.2.1 Channel Model

The mobile satellite communication system under discussion operates at Ku -band for transmission between satellite and gateway stations, and at L -band between the satellite and the mobile user, where a 6MHz to 9MHz band has been made available[15].

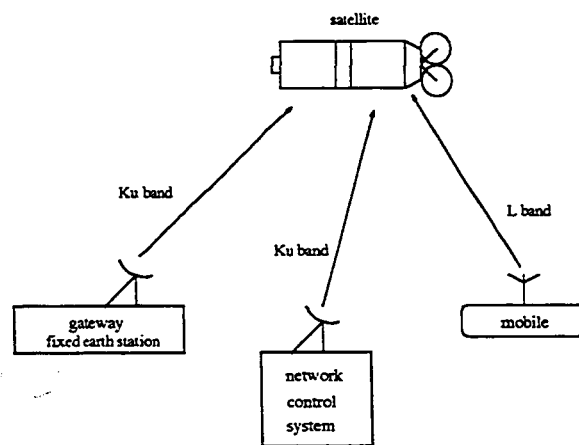

Figure 4.3: a mobile satellite system configuration

Because of low antenna height on mobile units, the human-made structures surrounding antennas cause multipath fading in the receiver signals. This is called *Rayleigh Fading* as shown in Fig.4.4. The multipath fading creates the burst error in digital transmission.

The wideband signal propagation can be described in terms of path loss and the signal fading. The characteristics of wideband signal fading are different from narrowband signal fading characteristics. The wideband signal fading is not as severe as the narrowband signal fading. The wideband signal has less fading because its reception takes advantage of the natural frequency diversity over the wideband signal.

There is nothing changed in our orthogonal coding modulation technique or our congestion control technique based on cell discarding, that forbids the application to narrowband or broadband satellite channels. Since our technique above are general in natural,

however, we have used the probability of bit error results of paper[13] which deals with selective multipath fading mobile channels, the treatment of bit errors in this work is general and straight forwardly extended to the broadband selective fading channel cases. Since the paper[13] gives values P_b results for a variable number of pathes and order of diversity, for the channels with "shadow wink", one needs to change analysis in the paper[13] lightly. Also, for flat fading cases, the same paper[13] contains corresponding bit error result which can be used.

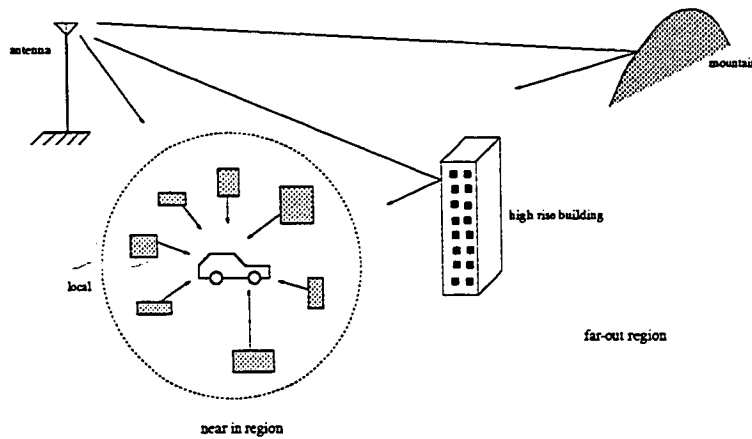

Figure 4.4: distribution of scatters in mobile radio environment

Moreover, the exact fading mode for the wideband Ku satellite channel is not fully formatted yet. In the near future, we plan to extant our results to this case. Basicly, The bit error analysis of our CDMA orthogonal system has to be evaluated by analysis or simulations, this will be followed by repeated simulations for our new congestion control and admission rules. This late items are the main concern of research. There is nothing in our new congestion control and admission rules that forbid the applications to the wideband satellite channel, our emphases is basically on those networking aspherics.

CDMA is more insensitive to fading than FDMA as long as reflected signals are delayed relative to the direct signal path by more than a chip period. Because of the

natural fading protection and the superior FEC potential, CDMA starts out with a much lower bit error-to-noise density ratio (E_b/N_o) requirement than FDMA.

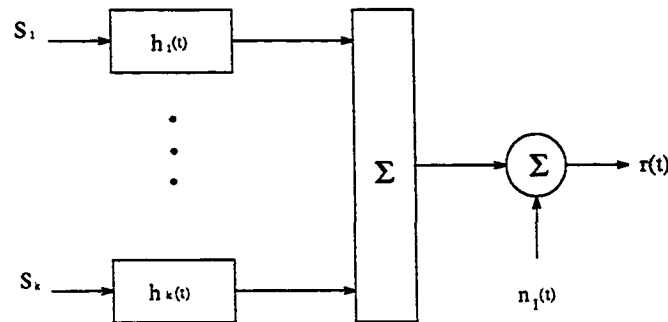

Figure 4.5: The block diagram of the channel model.

In our simulations, we studied fading effects peculiar to satellite channels. There are two types of fading channel, one is the frequency-nonselctive fading channel and the other is the frequency-selective channel. In the frequency-nonselctive fading channel the only source of diversity is the explicit or external diversity, this is marked by D. In the frequency-selective channel, multipath arrival provides another source of diversity which is referred to as the implicit or internal diversity, we marked this kind of diversity by L. Fig.4.5 shows the block diagram of the channel model. In the fading multipath channels, the channel impulse response for each user is given by,

$$h_k = \sum_{l=1}^L \beta_{lk} \delta(t - \tau_{lk}) e^{j\phi_{lk}} \quad (4.7)$$

where,

- β_{lk} is the path gain
- τ_{lk} is the delay.
- ϕ_{lk} is the phase
- $(\omega\tau_{lk} + \phi_{lk} + \theta_k)$ is the overall path phase

For the fading channel, the path gain β is assumed to be an independent Rayleigh distributed random variable. The overall path phase is assumed to be an independent uniformly distributed random variable in the region $[0, 2\pi)$. The most natural distributions for the random delay τ and the random interfering data B are the independent uniform distributions. Thus, we could assume that B and τ are independent.

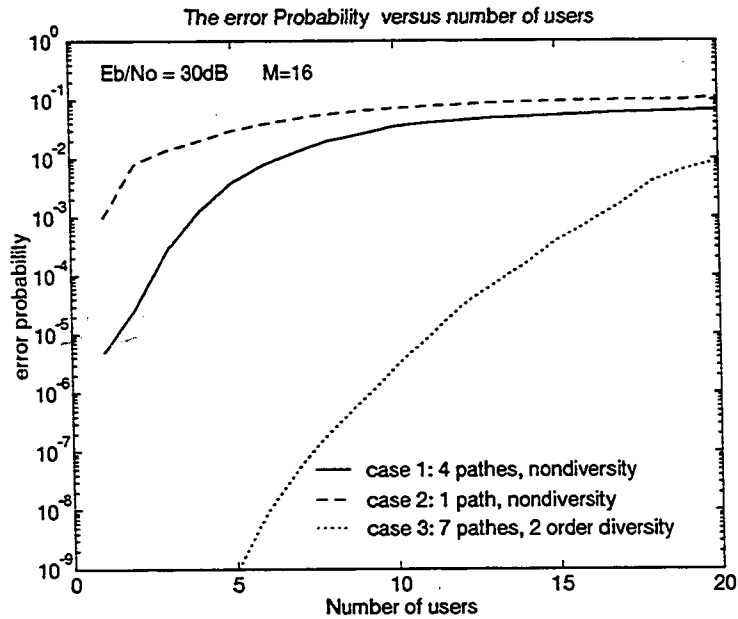

Figure 4.6: the error probability vs number of users

The received signal is the sum of all users signal plus noise, when the message sent by the first user is λ , the received signal at the receiver for the first user is given by[13],

$$r(t) = Re \left[\sum_{l=1}^L \beta_{l1} S(V_{\lambda}^{(l)}, t - \tau_{l1}) \exp(j\phi_{l1}) + \eta(t) \right] \quad t \in [0, T) \quad (4.8)$$

The additive noise term is,

$$\eta(t) = \eta_I(t) + \sum_{k=2}^K \sum_{l=1}^L \beta_{lk} S(b^{(k)}, t - \tau_{lk}) \exp(j\phi_{lk}) \quad (4.9)$$

where, $\eta_I(t)$ is the AWGN with power spectral density of height $N_0/2$, and the second term is the interference from other users with $S(b^{(k)}, t)$ representing the interfering signal from the k^{th} user. The interference from other users can come from the preceding or the succeeding symbol in addition to the current symbol. To remove the random delay affect, a RAKE demodulator for square law combiner is used as the receiver. From Eq.4.8 and Eq.4.9, it can be shown [13] that the average SNR for each path is,

$$\gamma = \left(\frac{N_0}{E_s} + \frac{2M_\Gamma (K-1)L}{NT_c^3} \right)^{-1} \quad (4.10)$$

where, M_Γ is a constant dependent on the chip waveform. In a frequency selective fading multipath channel with LD order of diversity and the average SNR is γ , the average probability of error for the RAKE demodulator with square law combiner is given by [13],

$$P_r(\epsilon) = 1 - \int_0^\infty \left[\frac{u^{LD-1} e^{-\frac{u}{1+\gamma}}}{(1+\gamma)^{LD} (LD-1)!} \left(1 - e^{-u} \sum_{j=0}^{LD-1} \frac{u^j}{j!} \right)^{M-1} \right] du \quad (4.11)$$

Fig.4.6 shows the error probabilities vs number of users over frequency selective fading multipath channel of three simulation cases, where, the code length in case 1 is $N = 127$, in case 2 and case 3, $N = 257$.

4.2.2 Traffic Model

Users of each class (video, voice, file and interactive data) only transmits in their dedicated subframe consisting of N_{S_i} slots. The succession of the four subframe constitute a TDMA

frame that repeat on the uplink channel. Each slot serves one ATM cell and by the vary route of DS/CDMA, i.e. interface rejection, several cells from different users of same class can overlap in the same slot with at causing terrible bit errors. The mode of operation is now easily recognized as a hybrid CDMA/ATM/TDMA.

In an ATM based networks, all information such as voice, data and video is conveyed using a fixed size cell. This constitutes a high speed multimedia network that can handle various classes of traffic with different bit rates and differences in the quality of services requirements. ATM multiplexing leads to more efficient use of network resources and it requires new kinds of bandwidth management and traffic control done by the user itself using an ATM/CDMA/TDMA interface.

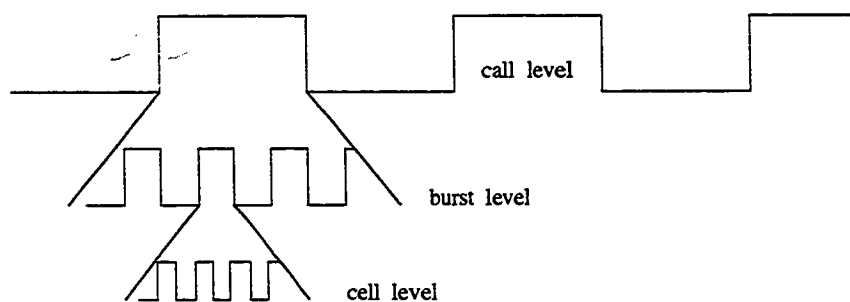

Figure 4.7: Three levels of ATM traffic

There are two types ATM traffic flow models in our simulations, one is the data-oriented users such as image and file transfer, this generate traffic flows witch move from a burst state, offering a continuous stream of cells at some peak rate, it is the Constant Bit Rate Sources, or CBR sources. The other is Video and Voice users, which generate a stream of correlated cell arrivals at a rate which may vary with time according to the coding scheme and motion in the users, this is the Variable Bit Rate Sources, or VBR sources.

Moreover, ATM traffic sources can be characterized statistically at several levels, in

our simulations, we arranged three level of the traffic, that is call level, burst level and cell arrival level. Fig.4.7 shows this three levels.

The CBR sources generate a constant cell stream. These type of sources are modeled as sources which generate cells equidistantly at their peak rate. When K independent users are multiplexed, the cell arrivals are governed by the number of active sources. The the number of cell arrival is assumed to be Poisson distributed with mean rate λ_d .

The VBR sources generate cells with relevant parameters, namely maximum cell rate, mean cell rate and mean peak rate duration, and these parameters could be varied independently each other. The voice users and the video users are VBR sources. Video user can be considered as an ON/OFF source because video signal has the intraframe variations. Intraframe variations arise because of scanning lines or processing blocks within a single frame. Also, video signals exhibit several fundamental periodicities, the most basic being the frame period. Most current video encoding algorithms operate on the frame as unit, and the correlations in the output bit rate naturally reflect the frame period. This is the structural periodicity of video signals.

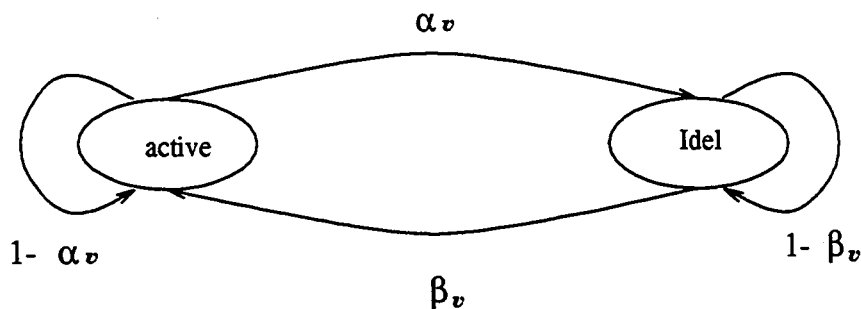

Figure 4.8: The two state VBR sources Model

The traffic generated by each VBR source is modeled as a two-state discrete time Markov chain. It is an interrupt Poison process. The transition probabilities between idle

and active period at any cell slot are α_v and β_v , shown in Fig.4.8. The probability of k active users is given by,

$$P_k = \binom{M_v}{k} p_v^k (1 - p_v)^{M_v - k} \quad (4.12)$$

where,

$$p_v = \frac{\alpha_v}{\alpha_v + \beta_v} \quad (4.13)$$

The probability of a user's call lasts L slots is given by,

$$P_L = (1 - \beta_v)^L \beta_v \quad (4.14)$$

In the active state, the user stay in the active state with probability $1 - \alpha_v$, and become silent state with probability α_v . In the silent state, the user became active state with probability β_v , and stay in the silent state with probability $1 - \beta_v$. If the user is in the active state, he may generate a cell, if the user is in the silent state, he does not generate a cell.

Assume the active burst duration, T_A , and the idle period, T_I , are geometrically distributed with parameters α_v and β_v , then,

$$T_A = T_s \cdot \sum_{k=1}^{WIN_i} (k-1) \cdot (1 - \alpha_v)^{k-1} \cdot \alpha_v \cong \frac{T_s}{\alpha_v} \quad (4.15)$$

$$T_I = T_s \cdot \sum_{k=1}^{WIN_i} (k-1) \cdot (1 - \beta_v)^{k-1} \cdot \beta_v \cong \frac{T_s}{\beta_v} \quad (4.16)$$

where, T_s is the time slot period in unit of second and WIN_size is the congestion control measurement window size in unit of cell.

4.3 Congestion Control Schemes LB/VLB

Congestion control in an ATM network is a challenge because the combined effects of high-speed channels and large propagation delays (typical of satellite networks) significantly limit the congestion control schemes applicable. To cope with the congestion control problem in an ATM network, it appears to be reservation of resources at each call setup, coupled with a control which policies each call, during the connection to guarantee the conformity parameters declared at call setup. That is, to protect the network from unexpected congestion due to the traffic fluctuation or the intentional violation of the contract, a policing or usage parameter control function is needed which monitors and controls the traffic streams during the life of each call. leaky Bucket Scheme is a promising method for preventive congestion control in ATM networks.

The **Leaky Bucket** corresponds to a counter which is incremented each time a cell is generated by the source and is decremented periodically with suitable leaky rate. When the counter has reached a given threshold, the arriving cell is dropped by leaky Bucket scheme, and it is marked as an excess cell by **Virtual leaky Bucket**.

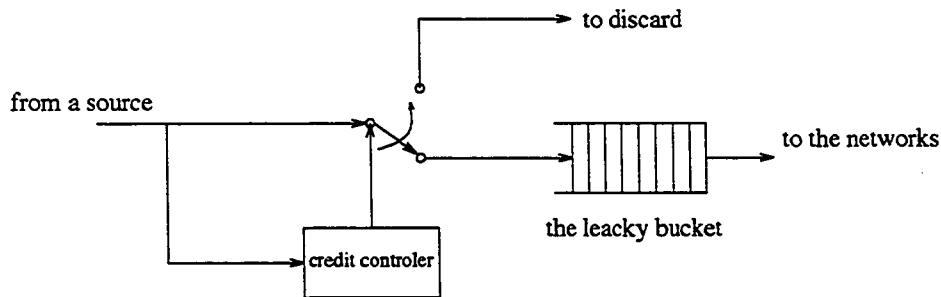

Figure 4.9: the block diagram of leaky bucket

Fig.4.9 shows the leaky Bucket scheme. The credit controller can dynamically control the counter threshold according to the state of the traffic source. To get different leaky Bucket policing, we can simply put the different algorithm in the credit controller.

Fig.4.10 shows the virtual leaky bucket scheme. The credit controller controls the counter threshold. The congestion detector acquires the congestion information from the networks and uses this information to control the marking switch which switches the excess cell to marking buffer or to discard. The Output Order Controller is to control the the leaky buckets switch, since there are two leaky buckets, we have to set the priority for one of them according to a certain algorithm. The control parameters of the leaky bucket are,

- the leaky rate a
- the buffer size N

The leaky bucket can be considered as a device performing a statistical test on the cells offered to the networks. By varying the characteristics of the test, we can adjust this two control parameters. and this gives some different policing. In our simulations, the TDMA/CDMA model has a fixed leaky rate, so we can adjust only the buffer size, however, we can adjust the two parameters for the CDMA/ATM model.

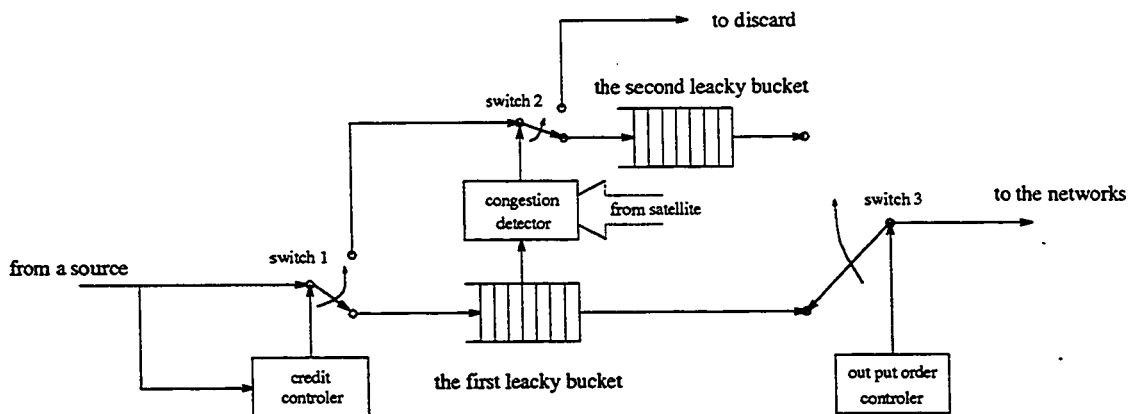

Figure 4.10: the block diagram of virtual leaky bucket

The leaky bucket can be considered as a device filtering the traffic flow offered by the source and allowing to load the network with a controlled flow. This is shown in Fig.4.11.

The filter function is,

$$a = \epsilon \cdot m_0 \quad (4.17)$$

where,

- a is the leaky rate
- m_0 is the mean bit rate of the source
- ϵ is a safety factor greater than one.

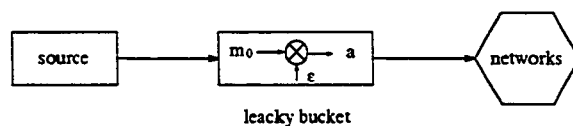

Figure 4.11: the leaky bucket as a filter

Usually, ϵ is fixed by the network manager. the greater is the safety factor ϵ , the smaller is the buffer size N , and the faster is the control.

4.4 Description of The Simulation

In this work, we show by computer simulation ways of alleviating congestion in ATM/CDMA broadband integrated satellite systems. A hybrid CDMA/TDMA/ATM approach is taken where a mixture of user classes namely video, voice, file and interactive data share a TDMA frame compared of four subframes where an ATM/CDMA technique is used by users of each class to access the time slots within their subframe. An M-array orthogonal sequence CDMA modulation is adopted and multipath fading satellite environment is assumed. Users are assumed to have the ATM/CDMA/TDMA interface and to commemorate their signals directly to the satellite in a hubless fashion.

In the simulations, we introduce congestion control using leaky bucket and virtual leaky bucket schemes. To compare the leaky bucket and the virtual leaky bucket schemes, we calculate the system delay, the cell discarding probability and the networks congestion probabilities. We also evaluate the bandwidth efficiency. To improve the bandwidth efficiency, we introduce the flow control scheme.

4.4.1 The CDMA/TDMA System parameters

We introduce the leaky bucket and virtual leaky bucket schemes into the CDMA/TDMA network to control congestions. A hubless system is assumed, the congestion control services are assumed to be done at the user site, each user has his own cell policing devices, a sending buffer and a preparing buffer. To provide the information for the cell policing, the users have to listen to the channel to make sure his cell is successfully sent. The generalised model is shown in Fig.4.12.

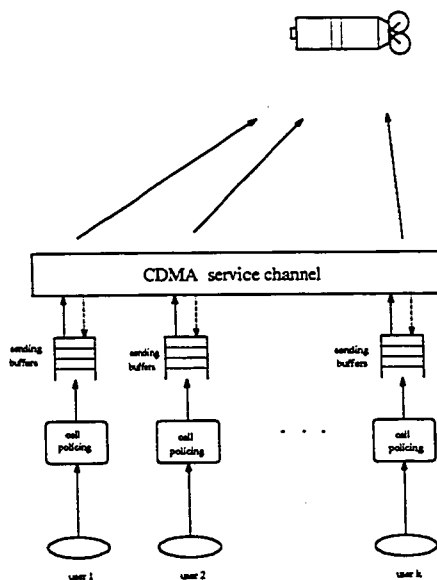

Figure 4.12: the simulation model of the CDMA/TDMA networks

In this simulation, we use TDMA to build the frame structure, and we apply CDMA in each time slot of the frame. In our simulations, the total number of time slots in the TDMA frame is $N_s = 40$, and we preassign these slots for four group users according to the user's peak rate. We assume that,

- the video user's peak rate $R_{P_{video}} = 158.4$ kbps
- the voice user's peak rate $R_{P_{voice}} = 9.6$ kbps
- the data user's peak rate $R_{P_{data}} = 19.2$ kbps
- the file user's peak rate $R_{P_{file}} = 4.8$ kbps

The spread spectrum system processing gain, PG , is the measure of the interference rejection capability, actually, the system processing gain is equal to the number of chips in a symbol interval, that is,

$$PG = \frac{T_s}{T_c} \quad (4.18)$$

where,

- T_c is the chip duration.
- T_s is the symbol interval.
- T_{S_i} is the i th class user's symbol interval on the actual CDMA/A TM/CDMA uplink frame.

In our simulations, since we divided the TDMA frame into forty slots, and assigned them to four classes, the CDMA system processing gain for each class is therefore,

$$PG_i = \frac{T_s}{T_c} = \frac{T_{S_i} \cdot N_{S_i}}{T_c \cdot N_S} \quad (4.19)$$

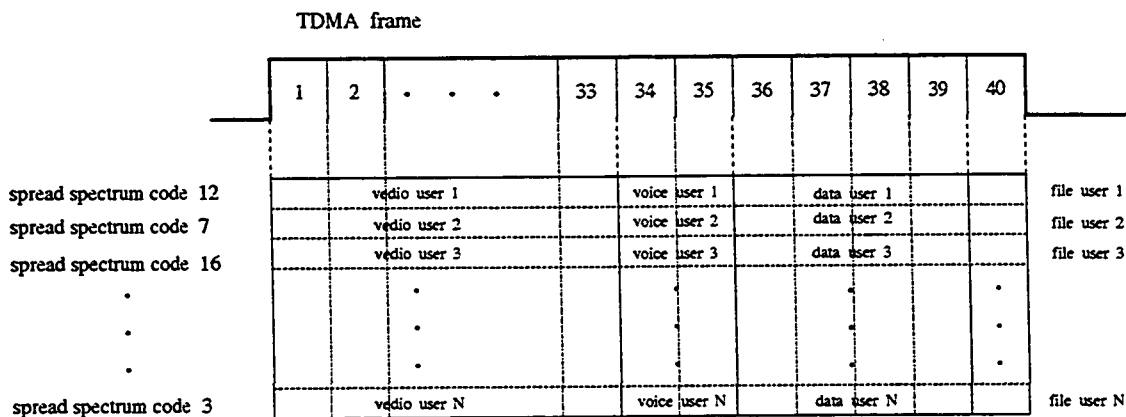

Figure 4.13: the hybrid CDMA/TDMA frame structure

If the total bandwidth of the system channels is W , and the signal bandwidth is B , then W and B are usually proportional to $1/T_c$ and $1/T_s$, respectively. therefore, if the proportionality constants are equal,

$$PG_i = \frac{W}{B} = \frac{W}{R_{P_i}} \cdot \frac{N_{S_i}}{N_S} \quad (4.20)$$

For example, the total bandwidth W is assumed as,

$$W = 6.144\text{MHz} \quad (4.21)$$

Because we assigned only one slot for the lowest quality user in each TDMA frame, the TDMA system processing gain is then,

$$PG = \frac{W}{N_S \cdot R_{P_{file}}} = \frac{6.144 \cdot 10^6}{40 \cdot 4.8 \cdot 10^3} = 32 \quad (4.22)$$

If the TDMA system processing gain is assumed as $PG = 32$, we can also find the total system bandwidth from,

$$W = PG \cdot \sum_{i=1}^4 R_{Pi} \quad (4.23)$$

thus,

$$W = 32 \cdot (158.4 + 9.6 + 19.2 + 4.8) \cdot 10^3 = 6.144\text{MHz} \quad (4.24)$$

In our simulations, TDMA serves the same traffic flow of each group users in their subframe, also, the spread CDMA system processing gain of each group in each time slot is the same. If we preassign one of forty slots for the lowest peak rate user, by Eq.4.20, the preassignments which is shown in Fig.4.13 is therefore,

$$N_{S1} = 33 \quad N_{S2} = 2 \quad N_{S3} = 4 \quad N_{S4} = 1$$

When a user is in the active state, he may generate their cells to the networks with certain generating probability depending on their peak rate in each time slot and TDMA serves them only at certain time slots. The generating probability is,

$$P_g(i) = \frac{PG \cdot R_{Pi}}{W} \quad (4.25)$$

In our simulations, since there are four classes of different bit rate users, we get four groups of different quality users, and the generating probabilities are different,

- video user, $P_g(1) = 82.5\%$
- voice user, $P_g(2) = 5\%$
- data user, $P_g(3) = 10\%$
- file user, $P_g(4) = 2.5\%$

4.4.2 The Traffic Source Parameters

Assuming that the TDMA frame length is T_F , and the ATM cell size is $L_p = 512$ bits, then

$$T_F = N_s \cdot L_p \cdot T_c \cdot PG = \frac{40 \cdot 512 \cdot 32}{6.144} = 0.107 \text{sec} \quad (4.26)$$

then the time slot in the frame, T_s , is,

$$T_s = \frac{T_F}{N_s} = \frac{0.107}{40} = 0.002 \text{ sec} \quad (4.27)$$

from Eq.4.15 and Eq.4.16, we can find,

$$\alpha = \frac{T_s}{T_A} \quad (4.28)$$

$$\beta = \frac{T_s}{T_I} \quad (4.29)$$

the four group user's active burst duration, T_A , and the idle period T_I are assumed,

- $T_{A_{vd}} = 0.8 \text{ sec.}$ $T_{I_{vd}} = 0.4 \text{ sec.}$
- $T_{A_{vi}} = 0.3 \text{ sec.}$ $T_{I_{vi}} = 0.7 \text{ sec.}$
- $T_{A_d} = 150 \text{ sec.}$ $T_{I_d} = 1.78 \cdot 10^{-3} \text{ sec.}$
- $T_{A_f} = 0.1 \text{ sec.}$ $T_{I_f} = 0.2 \text{ sec.}$

so that,

- $\alpha_{vd} = 0.005;$ $\beta_{vd} = 0.0025$
- $\alpha_{vi} = 0.003;$ $\beta_{vi} = 0.007$
- $\alpha_d = 0;$ $\beta_d = 1.0$
- $\alpha_f = 0.01;$ $\beta_f = 0.02$

To simplify the simulation and to reduce simulation time, we assume that all the four group sources have one frame active burst duration, this means that the user's active burst is at least 40 slots long. From this assumption, we can check the user's burst at the first slot of each frame only, however, this assumption is equal to enlarge the T_s to T_F , we have to transfer express α and β as an average value over the frame, that is,

$$\bar{\alpha}_i = \alpha_i \cdot N_s \quad (4.30)$$

$$\bar{\beta}_i = \beta_i \cdot N_s \quad (4.31)$$

therefore,

$$\bullet \bar{\alpha}_{vd} = 0.2; \quad \bar{\beta}_{vd} = 0.1$$

$$\bullet \bar{\alpha}_{vi} = 0.12; \quad \bar{\beta}_{vi} = 0.28$$

$$\bullet \bar{\alpha}_d = 0; \quad \bar{\beta}_d = 1.0$$

$$\bullet \bar{\alpha}_f = 0.4; \quad \bar{\beta}_f = 0.8$$

The system load can be measured by the factor of traffic intensity. The traffic intensity, ρ_i , is defined as,

$$\rho_i = \frac{\lambda}{\mu} \quad (4.32)$$

where,

- λ is the arriving traffic rate
- μ is the service rate

In our simulations, we assume each user generate only a maximum of one cell for each slot in the TDMA frame, therefore, the arriving average traffic rate in each slot is,

$$\lambda_{max} = k \cdot \frac{\beta}{\alpha + \beta} \cdot GL \quad (4.33)$$

ATM is also used in our simulations, that means all users' cells are the same size. For certain channel, under certain bit error probability, the maximum successful served traffic flow is fixed, if we assume the maximum successful traffic is μ_{max} per slot, the traffic intensity is therefore,

$$\rho_i = \frac{k_i \cdot \frac{N_i}{N_s} \cdot \frac{\beta_i}{\alpha_i + \beta_i}}{\mu_{max}} \quad (4.34)$$

thus, the number of users standing in the networks is,

$$k_i = \frac{\alpha_i + \beta_i}{\beta_i} \cdot \frac{N_s}{N_i} \cdot \rho_i \cdot \mu_{max} \quad (4.35)$$

4.4.3 The Congestion Control Parameters

After a connection is accepted, traffic flow of the connection must be monitored to ensure that the actual traffic flow conforms with that specified at call establishment. In our work, the bandwidth enforcement mechanism is implemented at the end of the network. Once a violation is detected, the traffic flow is enforced by discarding (leaky bucket) or buffering (virtual leaky bucket) violating cells.

Leaky bucket (LB) and Virtual Leaky Bucket (VLB) schemes can enforce the average bandwidth and the burst factor of a traffic source. A possible implementation of LB and VLB are shown in Fig.4.9 and Fig.4.10. To enter the network, a cell must first

obtain a credit from the credit controller. If there is no credit for the cell, this cell have to be discarded. There are many algorithm for generate credits, in our simulations, we use fixed window to manage the credit controller. The window structure is shown in Fig.4.14.

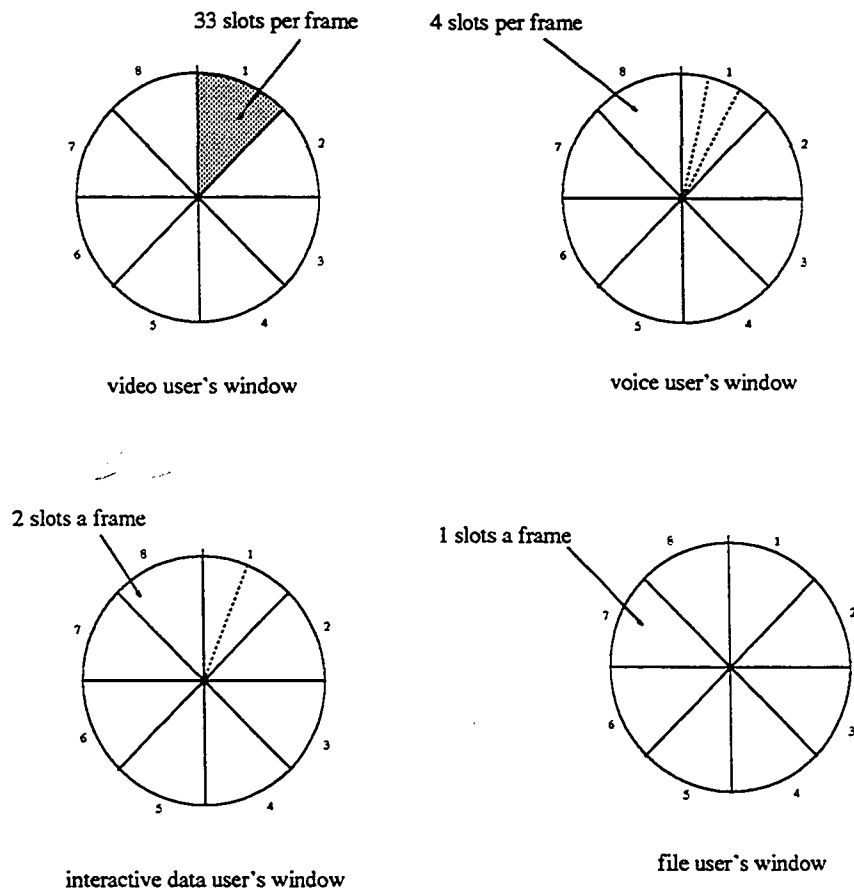

Figure 4.14: the window structure of the simulations

There are four credits generating thresholds for different user classes, we reset the credits generating counter at the first slot of each window. During a certain window, the credit controller generates credits for arriving cells when the generated credits is less than the credits generating threshold. If the generated credits exceed the credits generating threshold, the credit controller stop generating credit and all the rest cells will be discarded

during this window. The credits generating threshold is defined as,

$$THD_i = WIN_i \cdot Q_i \quad (4.36)$$

and,

$$WIN_i = N_{S_i} \cdot FT \quad (4.37)$$

where,

- THD_i is the credits generating threshold of i th user group
- WIN_i is the window size of the i th user group
- Q_i is the quality of the i th user group
- FT is the total number of frames in each window
- N_{S_i} is the number of slots of the i th user group in each frame

the window size in unit of slot. In our simulations, we assume that the total number of frames in the window is 8 frames. Q_i is the user's quality, each user have to pay for his quality in the networks, the higher quality costs more. Also, we can adjust the average bandwidth enforcement to the peak bandwidth enforcement by changing Q_i . In our simulations, if $Q_i = 1$, it is the peak bandwidth enforcement. We assume that the video user pay for 70%, voice user pay for 60%, data user 50% and file user 40% qualities, then the the credits generating threshold above which cells are discarded for each group is,

- video user, $THD_1 = 33 \cdot 8 \cdot 0.7 = 185$ cells
- voice user, $THD_2 = 2 \cdot 8 \cdot 0.6 = 10$ cells
- data user, $THD_3 = 4 \cdot 8 \cdot 0.5 = 16$ cells
- file user, $THD_4 = 1 \cdot 8 \cdot 0.4 = 3$ cells

Each user has his own counter to police his own traffic so the call agreement is not violated and thus no congestion will develop on the channel. During the update buffer phase, each user has to check his counter and compare to the above group credits generating threshold to determine how to buffer the new arriving cells. The update mechanism is shown in Fig.4.15.

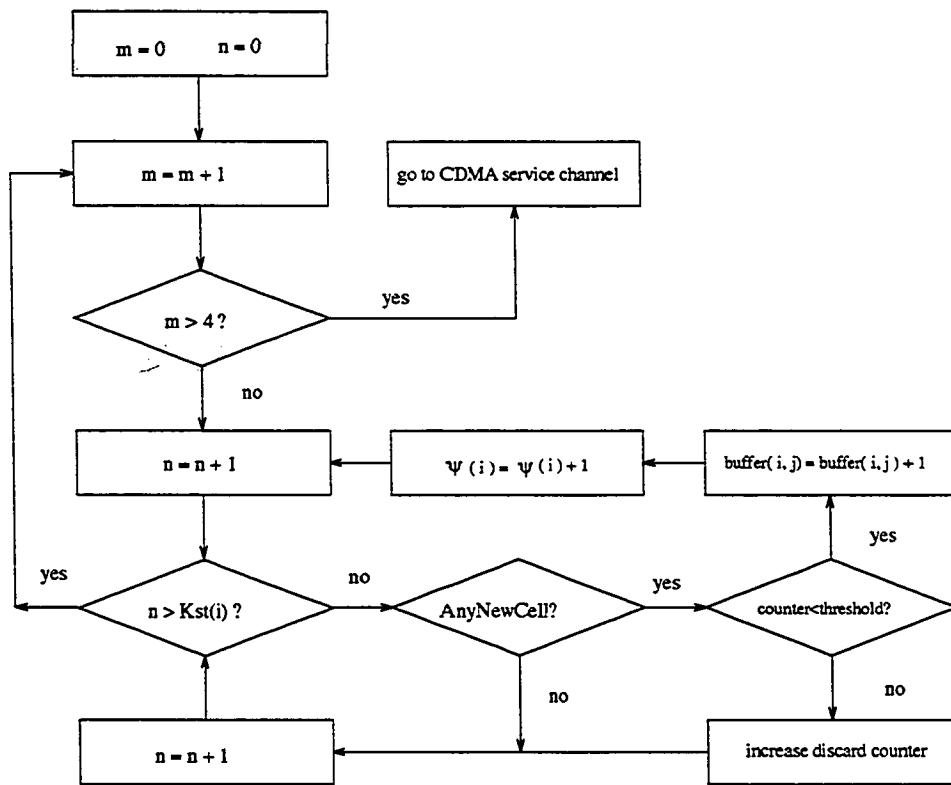

Figure 4.15: the buffer's update mechanism

4.4.4 The flow Control Parameters

The average bandwidth efficiency or utilization in fading multipath channels is very important for the DS/CDMA communications. The bandwidth efficiency η can be defined as,

$$\eta = \frac{K R_b}{W} \quad (4.38)$$

where R_b is the peak bit rate, W is the bandwidth of the channel, K is the number of users. In our simulations, since we have four group users, assume K_i is the number of users in each group the bandwidth efficiency is then,

$$\eta = \sum_{i=1}^4 \frac{\frac{\beta_i}{\alpha_i + \beta_i} \cdot K_i \cdot R_{P_i}}{W} \quad (4.39)$$

substitute Eq.4.38 into Eq.4.50, we get,

$$\eta = \sum_{i=1}^4 \frac{R_{P_i}}{W} \cdot \frac{N_S}{N_{S_i}} \cdot \rho_i \cdot \mu_{max} \quad (4.40)$$

substitute Eq.4.22 into Eq.4.51, we get,

$$\eta = \sum_{i=1}^4 \frac{\rho_i \cdot \mu_{max}}{PG} \quad (4.41)$$

Eq.4.39 shows that the bandwidth efficiency is mainly dependent on the traffic intensity ρ and the maximum successfully served traffic per slot, μ_{max} . For a certain channel, the load, μ_{max} , is a fixed value, therefore, to keep a higher bandwidth efficiency, we have to control the traffic flow.

An idea cell policing should be able to correctly identify all the violating cells and discard or tag only violating cells. It should also be able to detect violation rapidly once

it occurs. However, the burst nature of the traffic carried in ATM networks makes it difficult to implement such an idea scheme. When the traffic is bursty, a large number of cells may be generated in a short period of time, yet conform to the traffic indicator values claimed at time of call establishment. For instance, the average cell arrival rate can be kept constant if cells do not arrive for a while, even if there is a burst of cell arrivals in a short time period. In this case, non of these cells should be considered violating cells. If a small value is used for a threshold, some of the cells will be falsely identified as violating cells. Therefore, a relatively large threshold value must be used to avoid discarding or tagging nonviolating cells. However, this large threshold value makes it harder to distinguish truly violating transmissions from temporary burst transmissions. As a result, in an ATM/CDMA environment it may be more desirable to apply a flow control in order to avoid undesired enforcement action by the network. That is we use the large threshold value and we also set an optimum threshold value as the flow control threshold, if a large number of cells was generated in a short period of time, the flow control will let the extra cells queue until next sending slot. Fig.4.16 shows the concept of ATM/CDMA flow control.

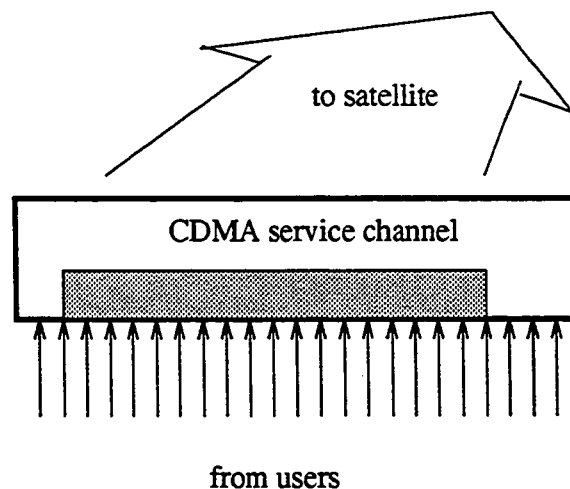

Figure 4.16: the flow control n ATM/CDMA system

In our simulations, we set a sending threshold to control the traffic flow, the congestion control processor on board of the satellite checks the active buffers every slot, if the number of active buffers is more than the sending threshold, then the satellite sends a pilot signal in the down link frame. At the receiver, if they received the pilot signal, they chop their sending by certain probability and let the cells queue. This mechanism is shown in Fig.4.17.

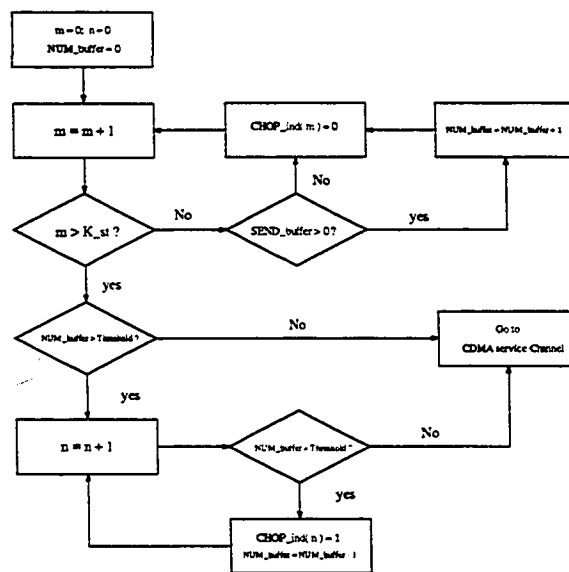

Figure 4.17: the flow control mechanism

The maximum successfully served traffic flow depends on an assumed acceptable successfully sending probability, P_C , the lower the successful sending probability, the more the maximum served traffic flow, μ_{max} , and subsequently, the more the system delay. In our simulations, we set the successful sending probability at 50% and more, the transmission threshold is μ_{max} , therefore,

- case 1: $\mu_{max} = 5$ $P_{Cmin} = 0.599$.
- case 2: $\mu_{max} = 1$ $P_{Cmin} = 0.86$.
- case 3: $\mu_{max} = 14$ $P_{Cmin} = 0.59$.

4.5 Simulation Flow Charts

We simulate the leaky bucket and the the virtual leaky bucket schemes in a hobless ATM/CDMA/TDMA system. Fig.4.18 shows the whole simulation feature.

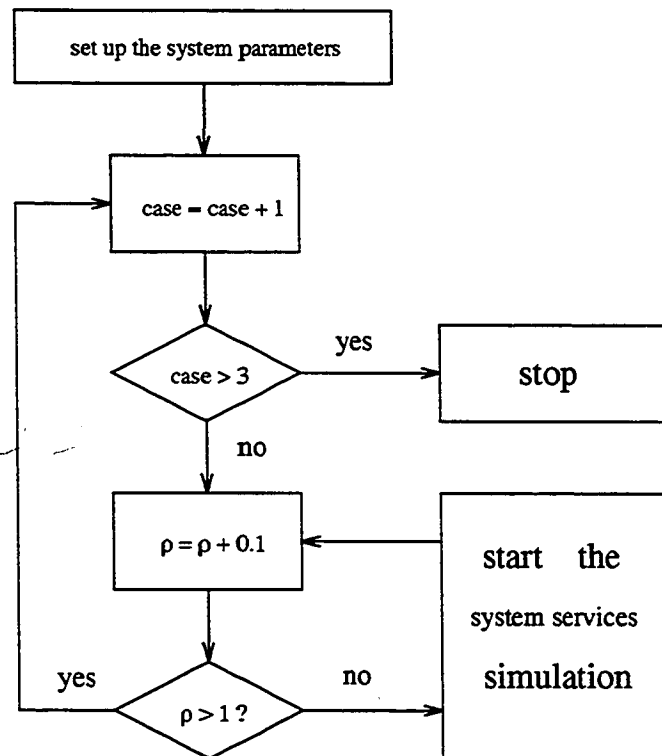

Figure 4.18: the main flow chart of the simulation

We simulate the congestion control simulation over three different channels,

- case 1: one path no diversity frequency nonselective fading channel
- case 2: seven paths two orders of explicit diversity frequency selective fading channel
- case 3: frequency selective fading multipath channel used different code length

Our simulations calculate all the system performances as a function of the traffic intensity ρ . We increase ρ by the step of 0.1 as shown in Fig.4.18. The more details of the simulation is shown in Fig.4.19.

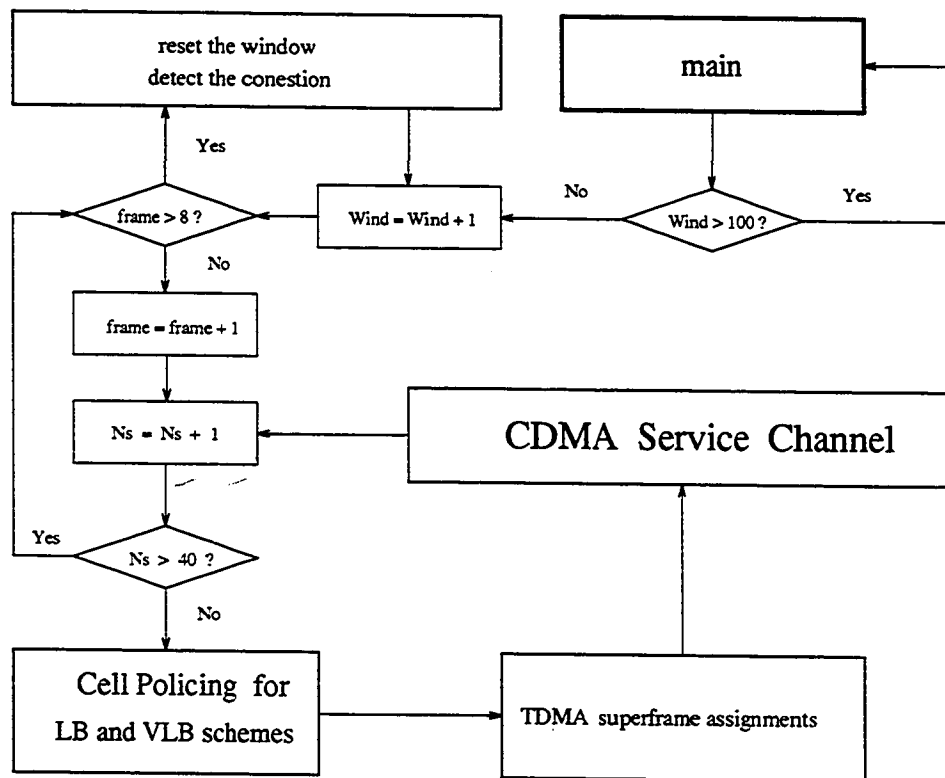

Figure 4.19: the flow chart of system services

In the system service, we have Window Reset Function, Cell Policing Function, TDMA Frame Assignment Function and CDMA service channel. The Policing Function and CDMA service channel are run at each time slot, Window reset function is run at the beginning of each window.

To get a close to real time results, we have to run the simulation in a very long time. Our simulation time is 100 windows or 800 TDMA frames. At the beginning of each window, we reset the window parameters, such as window counter, frame counter and the

generating counter. Also, at the beginning of each window we detect the congestion feature in the network. The window reset mechanism is shown in Fig.4.20.

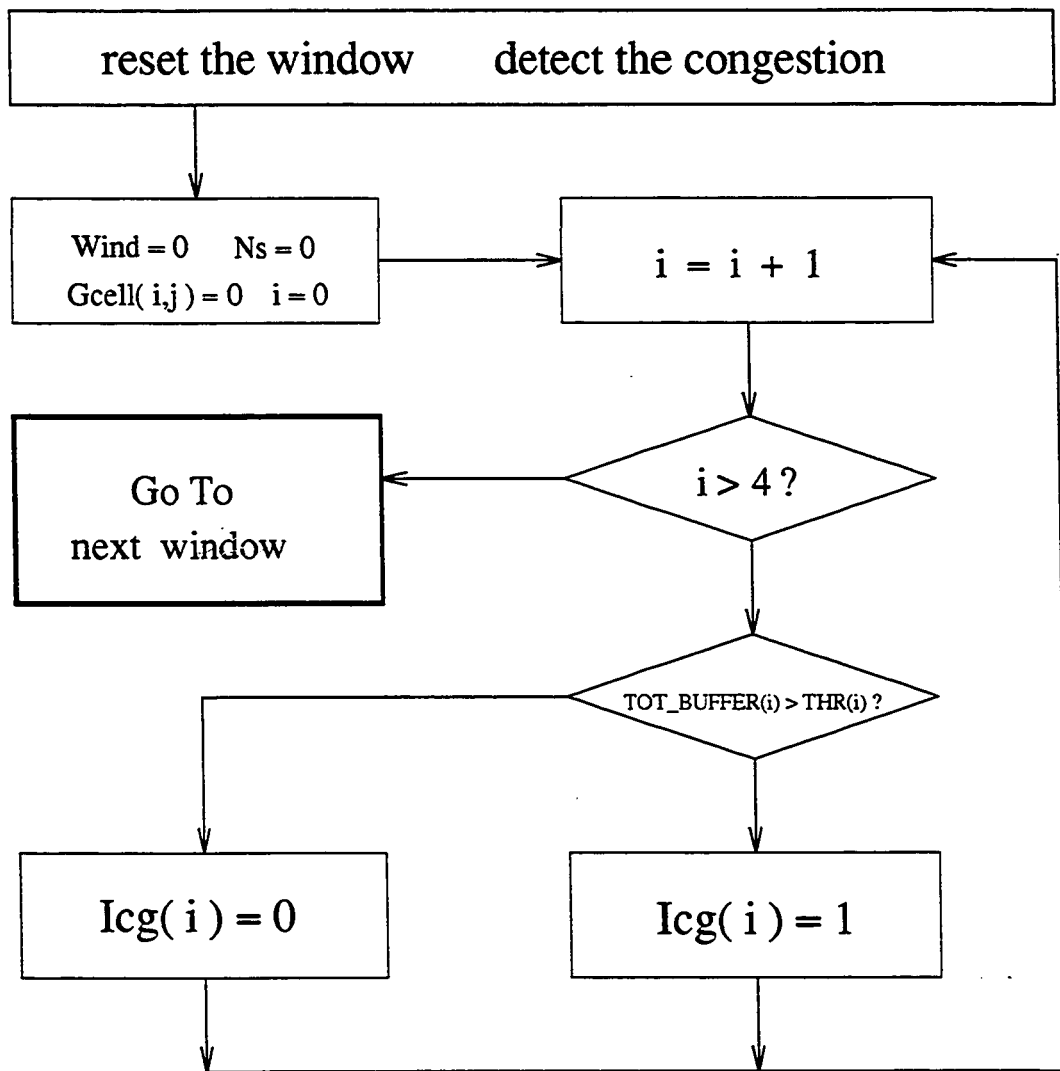

Figure 4.20: the window reset and the congestion detection mechanism

The Cell Policing Function is the simulations of Leaky Bucket and Virtual Leaky Bucket congestion control mechanism which is shown in Fig.4.21 and Fig.4.22.

Fig.4.21 shows the flow chart of the cell policing function for Leaky Bucket scheme.

This mechanism is done in each slot. The function check all active burst users to find if they generate cells. If a user generates a cell then check his leaky bucket counter $G_{cell}(m, n)$ to see if the cell is a violating cell. If the cell is not a violating cell then put it into the sending buffer and the cell will be served by CDMA service channel. After checking all the burst users, the function go to check all the standing calls in the network to update the number of active burst users.

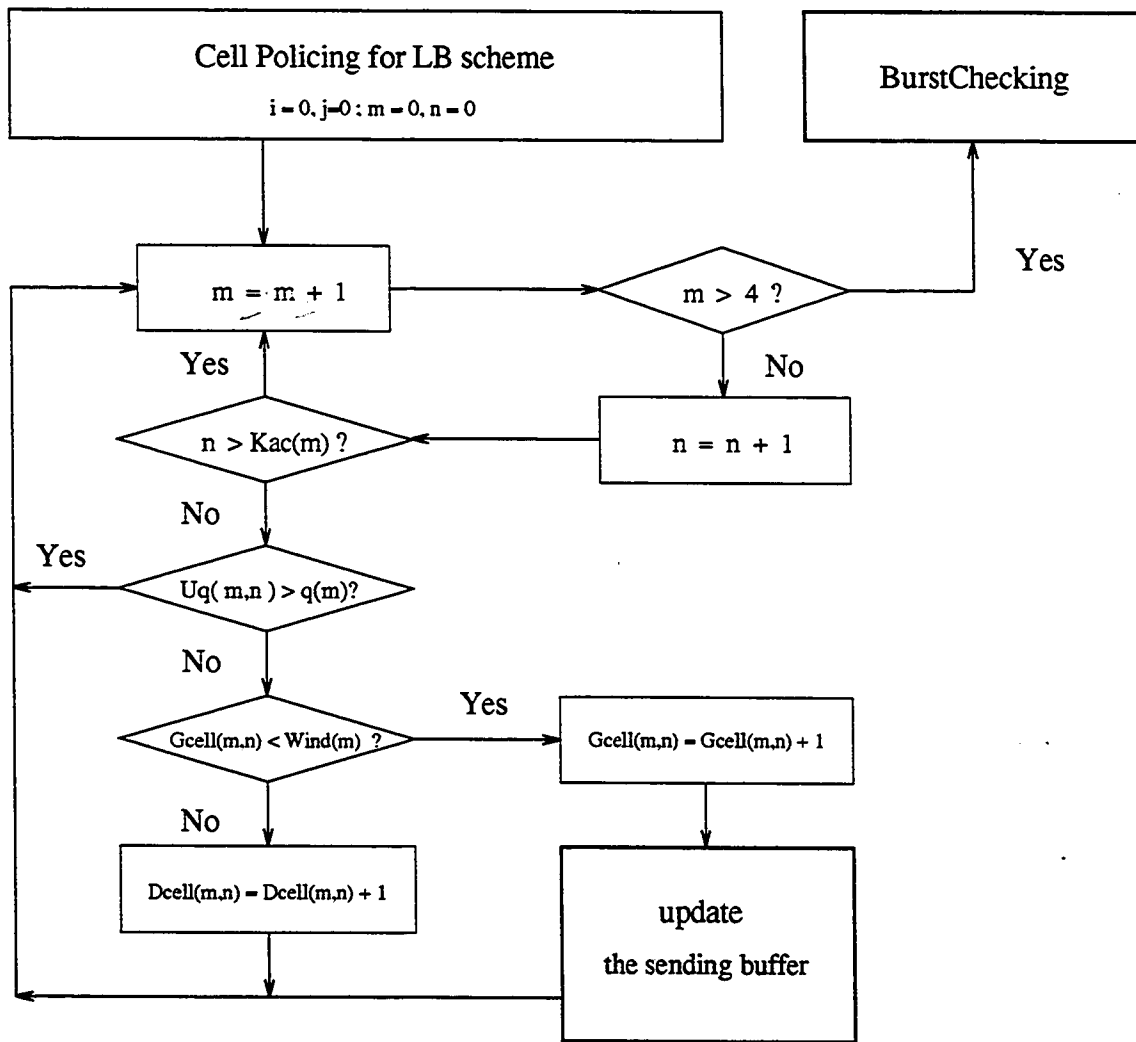

Figure 4.21: the cell policing mechanism for LB

Fig.4.22 shows the flow chart of VLB cell policing function. This mechanism is for Virtual Leaky Bucket scheme which is done in each slot. The only different from Leaky Bucket mechanism is when a cell is the violating cell, VLB checks the congestion indicator, if there is no congestion in the network, then marks the cell, otherwise, discard all the marked cells in the buffer.

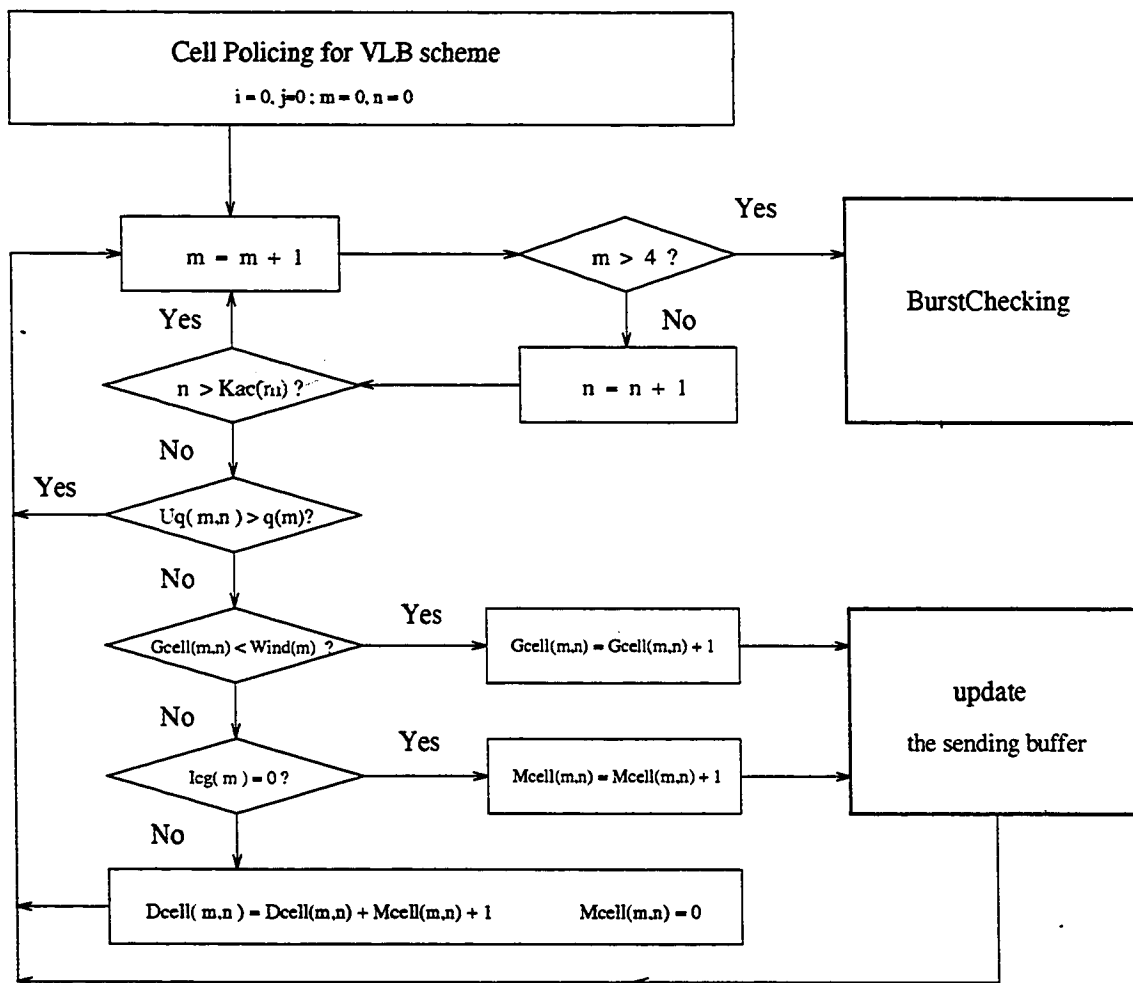

Figure 4.22: the cell policing for VLB

Fig.4.23 shows the flow chart of burst checking function. The Burst Checking mechanism is done at the first slot of each frame. Actually, this function should be done in each

slot. In our simulation, however, to save simulation time, we just run this function once per frame, to do so, we modified some traffic parameters.

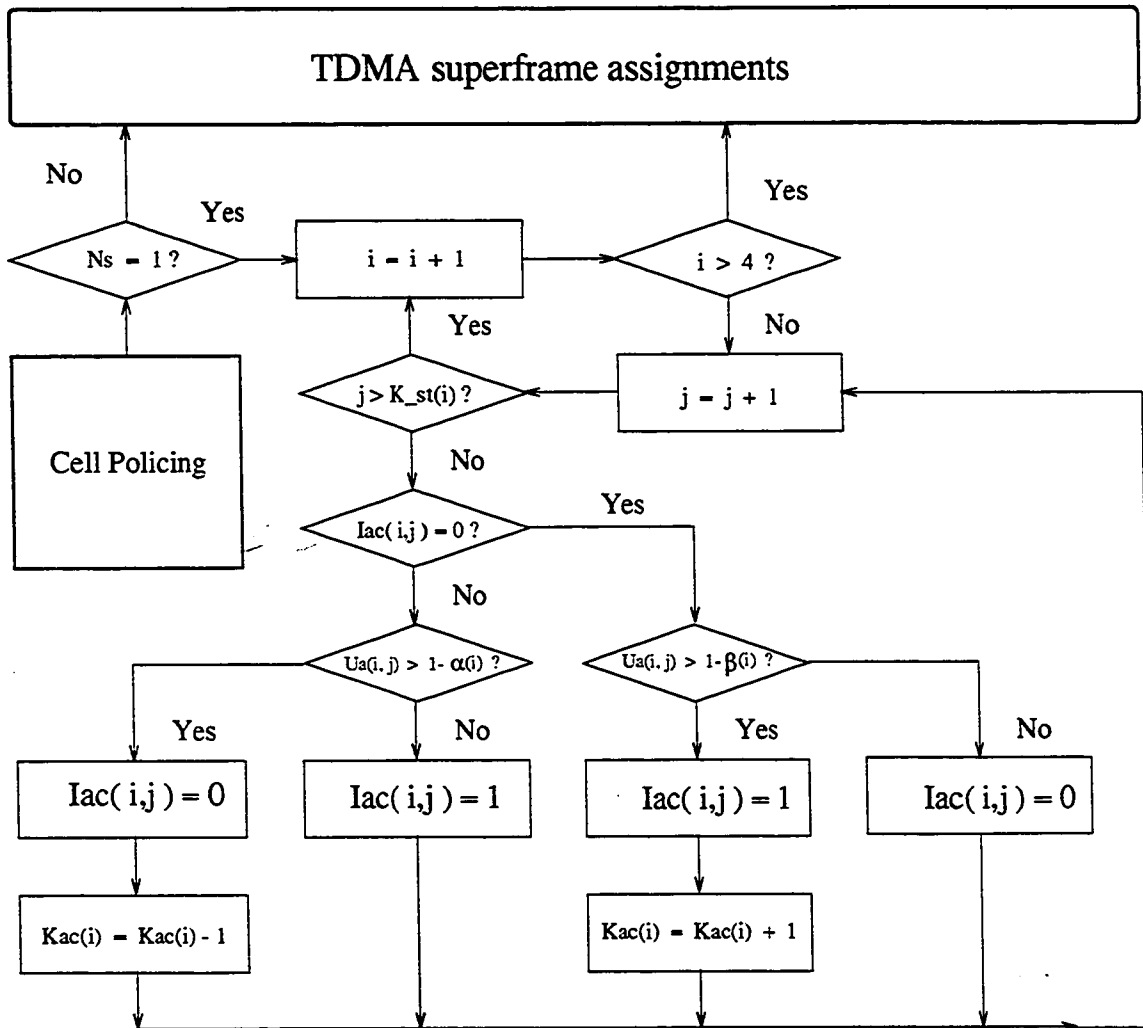

Figure 4.23: the burst checking mechanism

After the Burst Checking mechanism, the simulation go to the function of TDMA superframe assignments. Our system is a hybrid ATM/CDMA/TDMA, and we have four classes users, each class users assign some slots in the TDMA superframe. the mechanism of this assignments is shown in Fig.4.24.

The function is done in each slot, it first check the slots number which is equivalent to the address in the TDMA superframe. We have the the assignments that the first 33 slots for video user, the next two slots for voice user, and the following four slots for file user and the last slot for interactive data user. After got the address in the TDMA superframe, the function then sign the slot to the suitable class users.

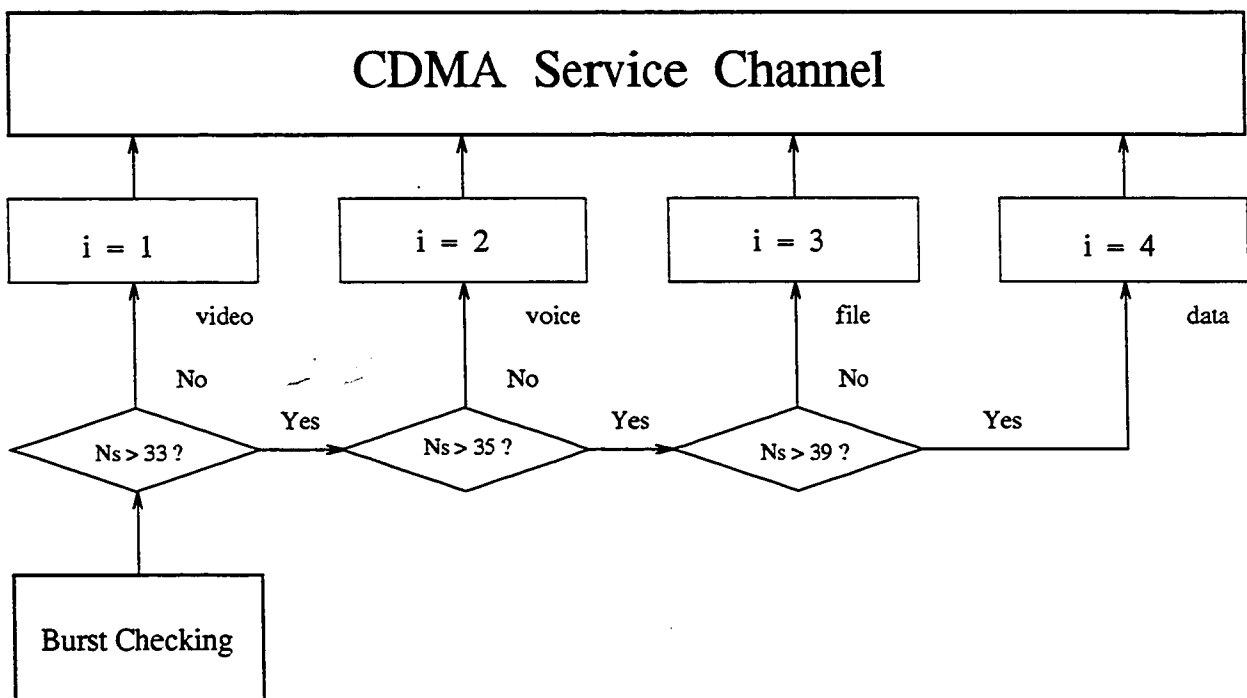

Figure 4.24: the TDMA superframe assignments

The CDMA Service Channel mechanism is done in each slot which is shown in Fig.4.25. In each slot, after the flow control mechanism, the CDMA Service Channel function (CSCF) calculates the successful sending probability.(The successful sending probability is a function as system load, it decreases when the number of cells in the slot is increasing). And then, the CDMA Service Channel function tests if this is a successful slot by comparing the calculated value with a designed value. If it is a successful slot, then CSCF moves the cells from the each user's sending buffer to the TDMA superframe and

then go to next slot. If it is not a successful slot, CSCF simply ignore this slot, no cell will be moved out from user's sending buffer.

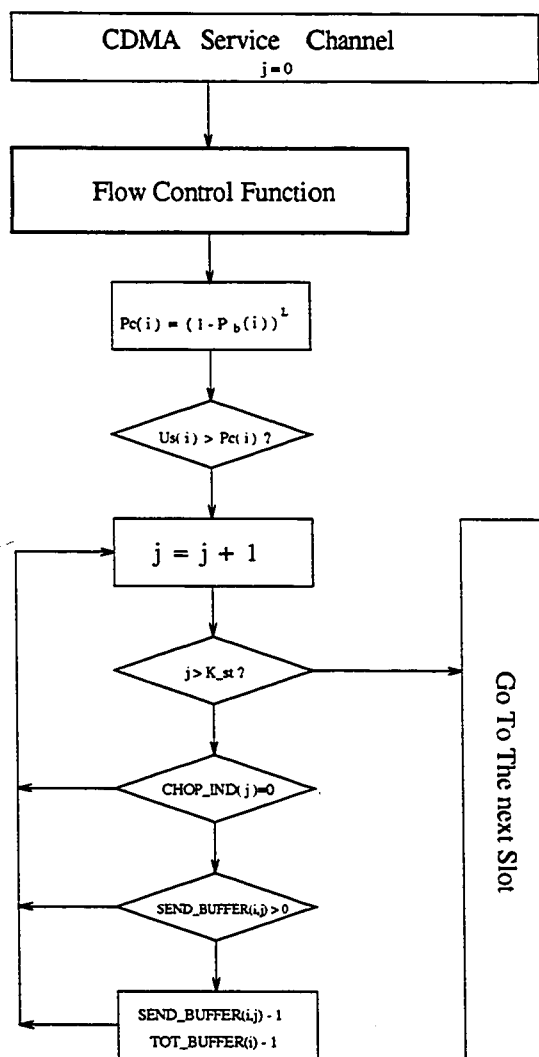

Figure 4.25: the CDMA service channel

4.6 Simulation Results

Simulations were carried out to calculate the system transmission delay D as a function of the traffic intensity of the system ρ for the four different group users, for both the leaky bucket and the virtual leaky bucket schemes. By D , we denote the average number of cells that each user has in its buffer in each slot, and the traffic intensity is denoted by ρ , which is the ratio of incoming traffic and served traffic, for $\rho = 1$ means that all the acceptable active calls are standing in the networks.

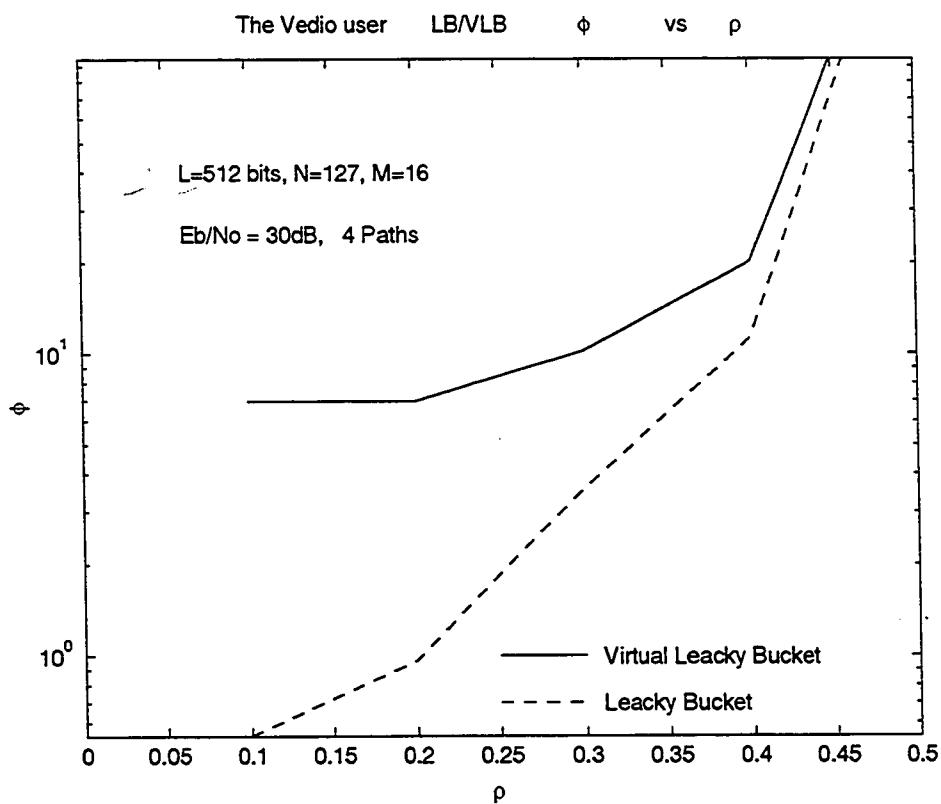

Figure 4.26: the video user's delay

VLB scheme is the way to bring the system into the best load capacity, this scheme marks the violated cells, if there is no congestion in the network, these cells may transmit,

if there is congestion in the network, these cells will be discarded. So, VLB scheme is more efficient in the low traffic case.

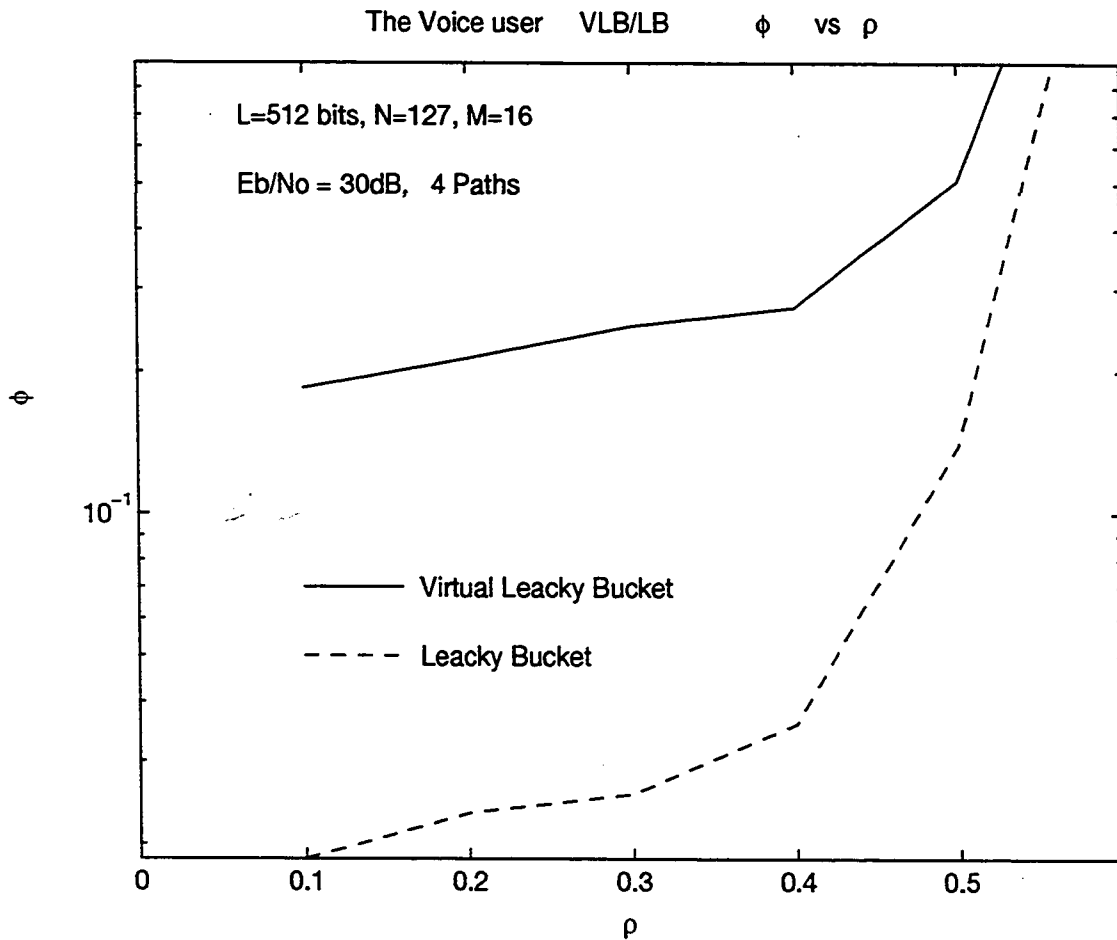

Figure 4.27: the voice user's delay

Fig.4.26 shows the video users in both the leaky bucket scheme and the virtual leaky bucket scheme. The advantage of the leaky bucket scheme is clear, that is, the delay of the leaky bucket scheme is much less than the virtual leaky bucket scheme, especially in the low traffic ranges. In the high traffic range, the difference between LB and VLB is small,

this is because at the high traffic situation, there are more congestions in the network, VLB will discard all the marked cells at this time, thus LB and VLB almost the same.

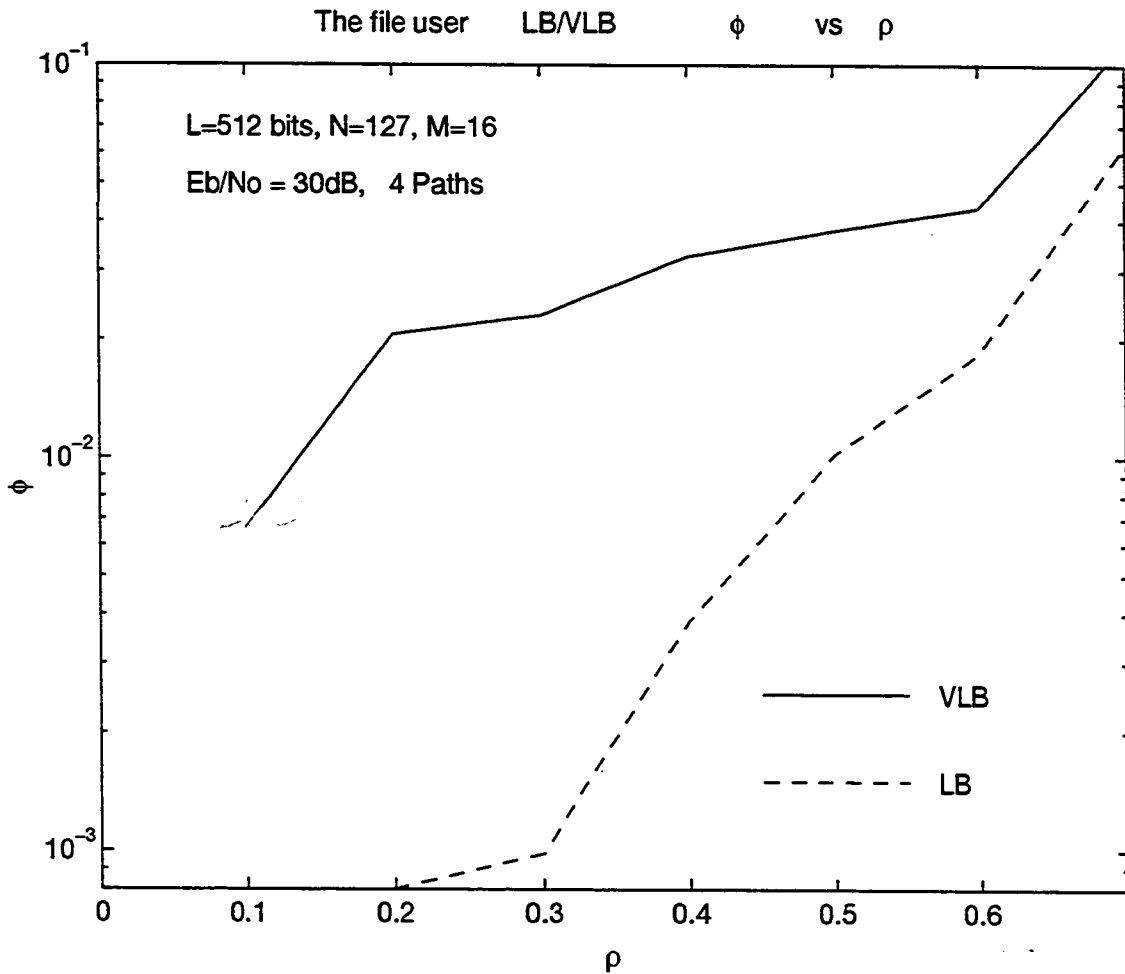

Figure 4.28: the file user's delay

Fig.4.27, Fig.4.28 and Fig.4.29 show the other three group users' delay function compared the LB and VLB.

Fig.4.27 shows the voice user's delay function, the only difference from the video user's is that voice user's delay is much less than the video user's and the delay function

shooting away (the dead lock will be shown) at $\rho = 0.5$ instead of video user's $\rho = 0.4$.
 this is easy to understand because video user got more traffic than voice user.

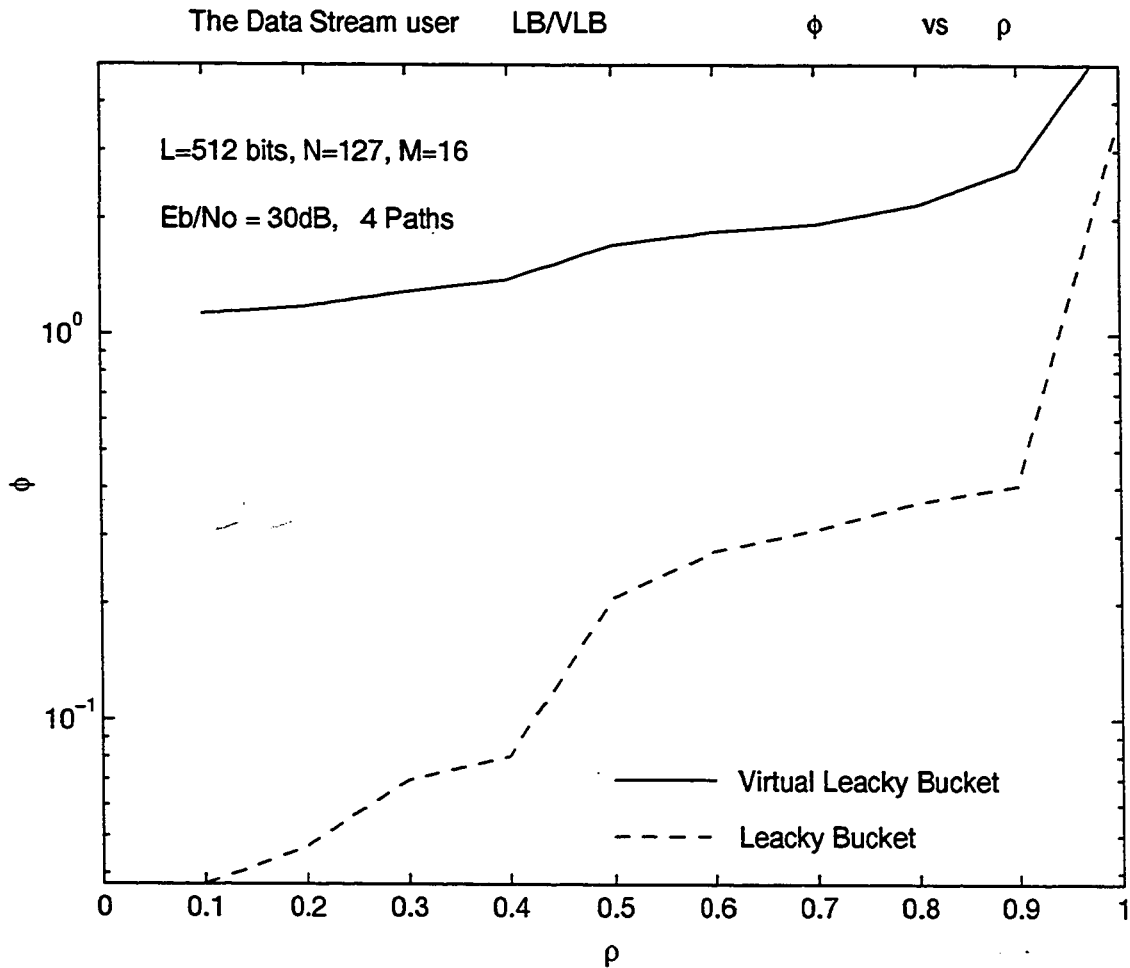

Figure 4.29: the data stream user's delay

Fig.4.28 shows the file user's delay function. In fact, the VLB scheme is the most efficient for the file users, since the file user are not delay sensitive but cell discard is more relevant, and VLB scheme is the way to use more delays to get less discarding.

Since the file user's traffic is much less than the video and voice user's, from the

Fig.4.29, we see the delay function is shooting away (the dead lock will be shown) at $\rho = 0.6$, and we also see that the VLB delay function is much more than LB.

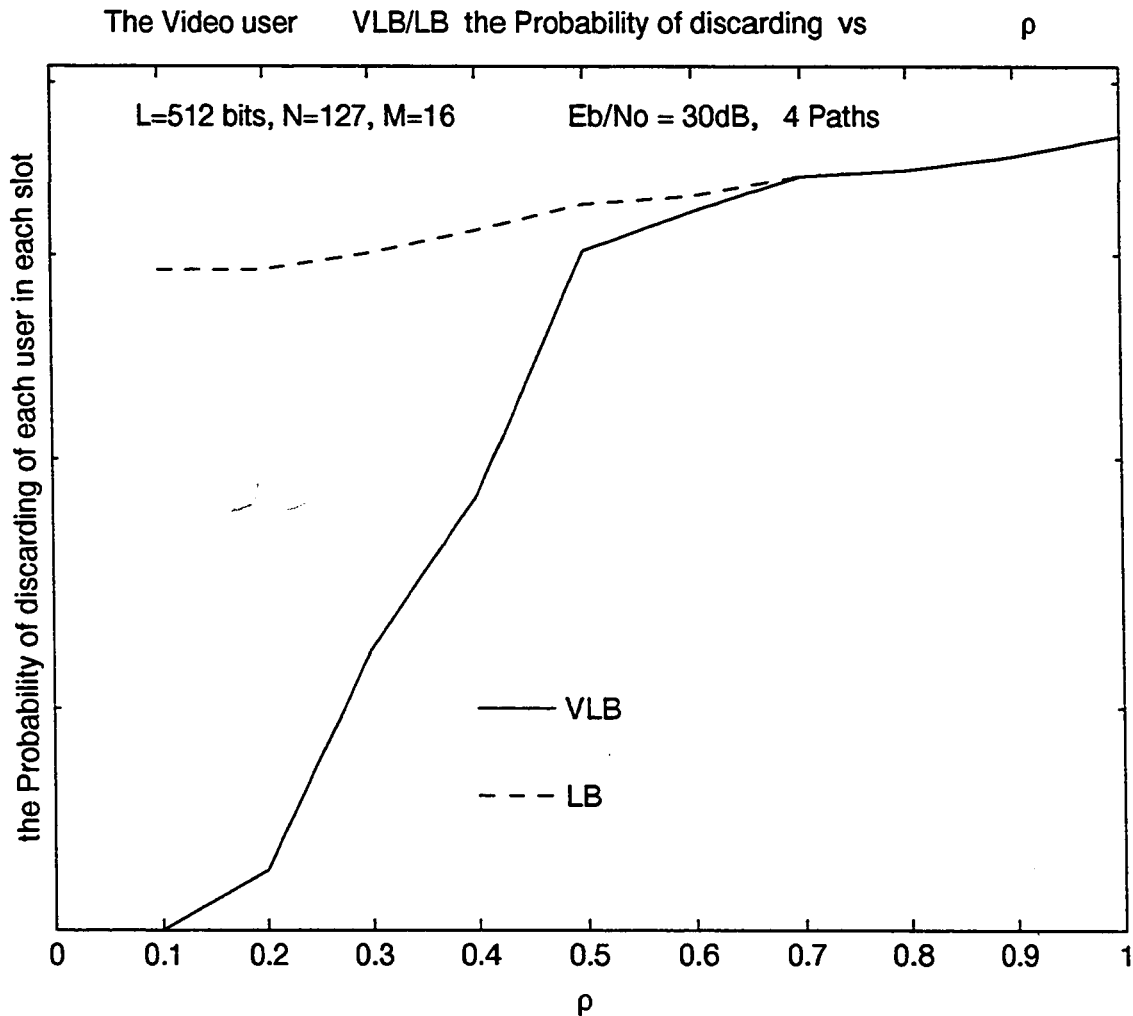

Figure 4.30: the video user's discard

The data stream user is assumed in our simulations. This kind of user generates cells all the simulation time, or we say that the traffic parameters $\alpha = 0$, $\beta = 1$, this is high traffic users. However, we allow only a few this kind of users, and we assigned four

slots in each frame for this kind of users.

From Fig.4.29, we see that the delay function is shooting away at $\rho = 0.9$, this does not mean the users are low traffic group, this is a high traffic group like we analysis, but we allow only a few users admission into the network to keep the network work efficient.

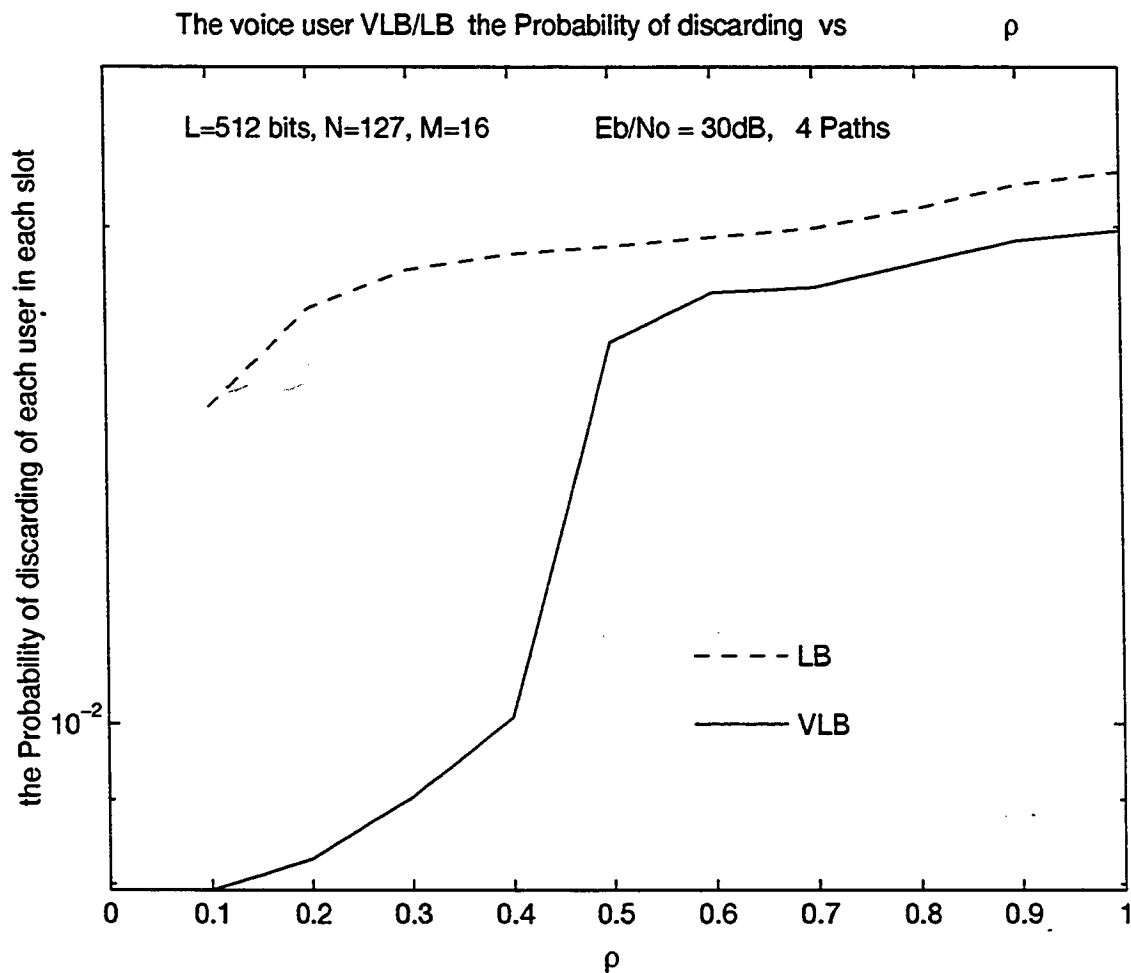

Figure 4.31: the voice user's discard

This kind of users do not care the delay too much either, but care more about discard, so VLB is a good way for this kind of users.

The simulations were also carried out calculate the discarding probability by the system as a function of the traffic intensity of the system, ρ , for the four different group users, for both the leaky bucket scheme and the virtual leaky bucket scheme. as the previous, the traffic intensity, ρ , is the ratio of incoming traffic and the system could served traffic.

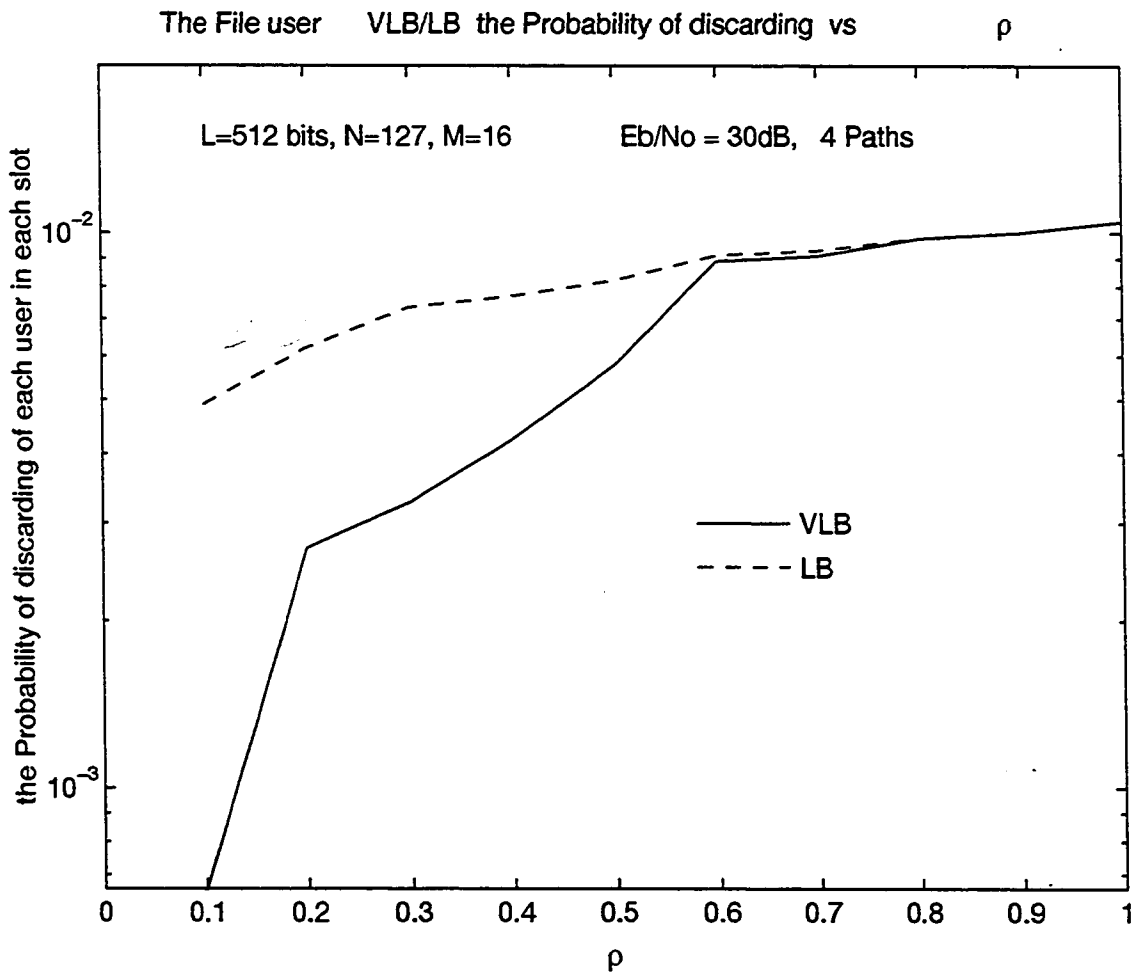

Figure 4.32: the file user's discard

Fig.4.30 shows the video users in both the leaky bucket scheme and the virtual leaky

bucket scheme. The advantage of the virtual leaky bucket scheme is clear, that is, the system discarding probability, or say cell losing probability, is much less than LB schem.

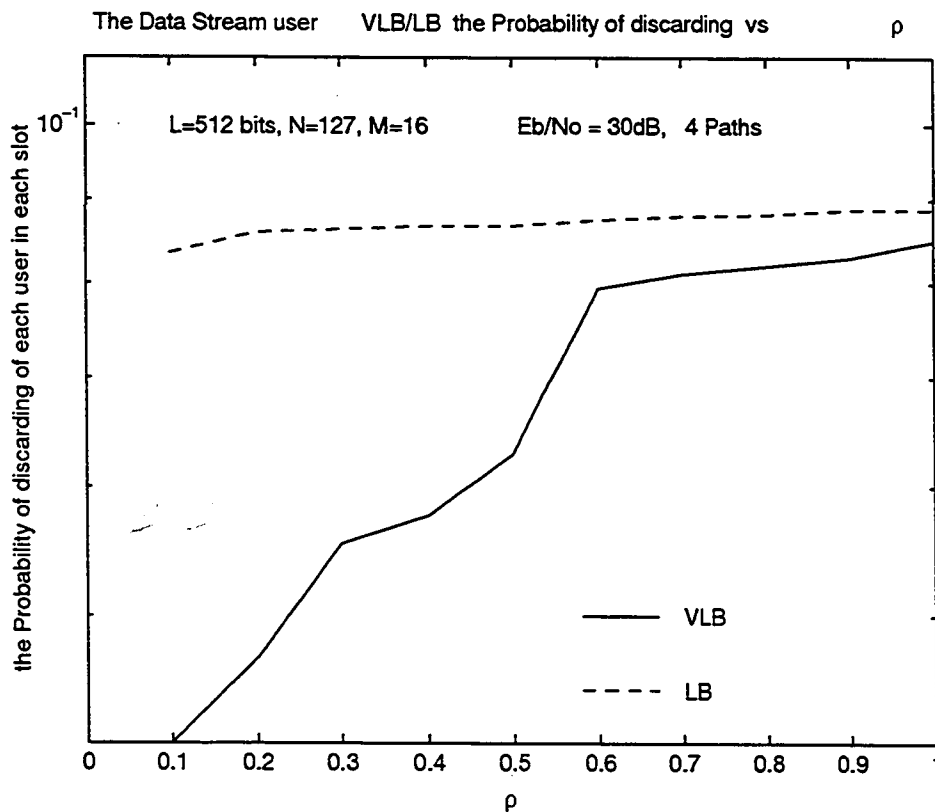

Figure 4.33: the data stream user's discard

From Fig.4.30, we see that the discarding probability of LB is almost a flat function, this means that even in the low traffic, the LB scheme still makes a large number discarding cells, this flat function caused by the fixed counter threshold of each group users. The users in the same group have the same counter threshold, if they generate more cells than the threshold during a window, they have to chop these cells. So that, for LB, the average discarding probability of each user is almost the same. However, the VLB schem shows a very nice curve that the discarding probability is progressively increasing followed by

the increasing traffic, this is caused that, VLB makes discarding only when there is the congestion in the networks. VLB discarding curve is a reasonable function, but it is in cost of increasing delay in the system. We can find a optimum position from comparing the discard function and the delay function to keep our system work more efficient.

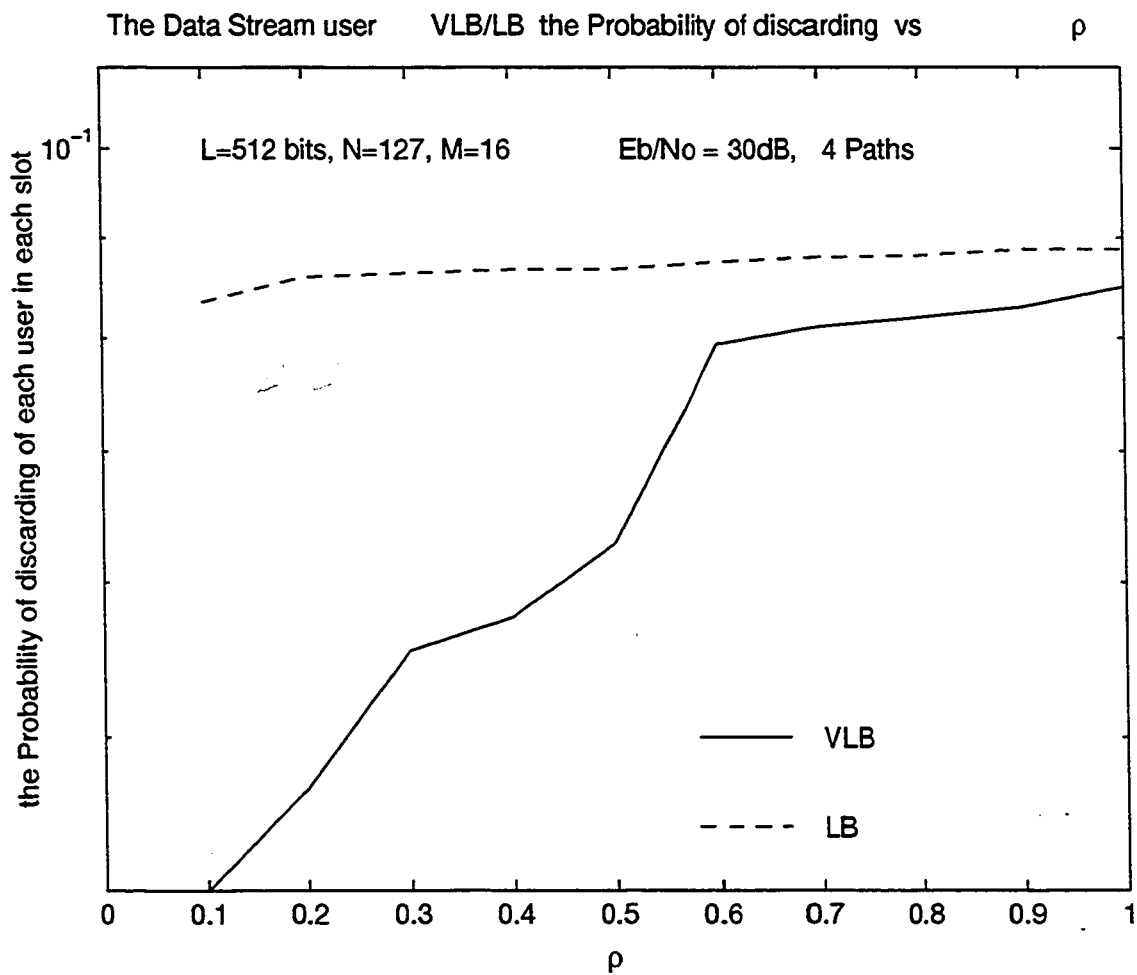

Figure 4.34: the data stream user's discard

Fig.4.31 show the voice user's discarding function in both LB and VLB. Voice users care not very much about the discarding cells, actually, we can ask the other user repeat, but

only a few words and a few times. From Fig.4.31, we see that VLB's discarding probability is much less than LB's even in the high traffic range.

Fig.4.32 shows the file user's discarding function in both LB and VLB. The file users care very much about the discarding cells. If they lost a cell, in most cases they have to retransmit the cell. To keep lower discarding probability, we need the VLB scheme. From the figure, we can see, in the low traffic range, $\rho < 0.6$, the VLB's discarding probability is progressively increasing followed by the increasing traffic, and the LB's discarding probability is a flat function at the high level.

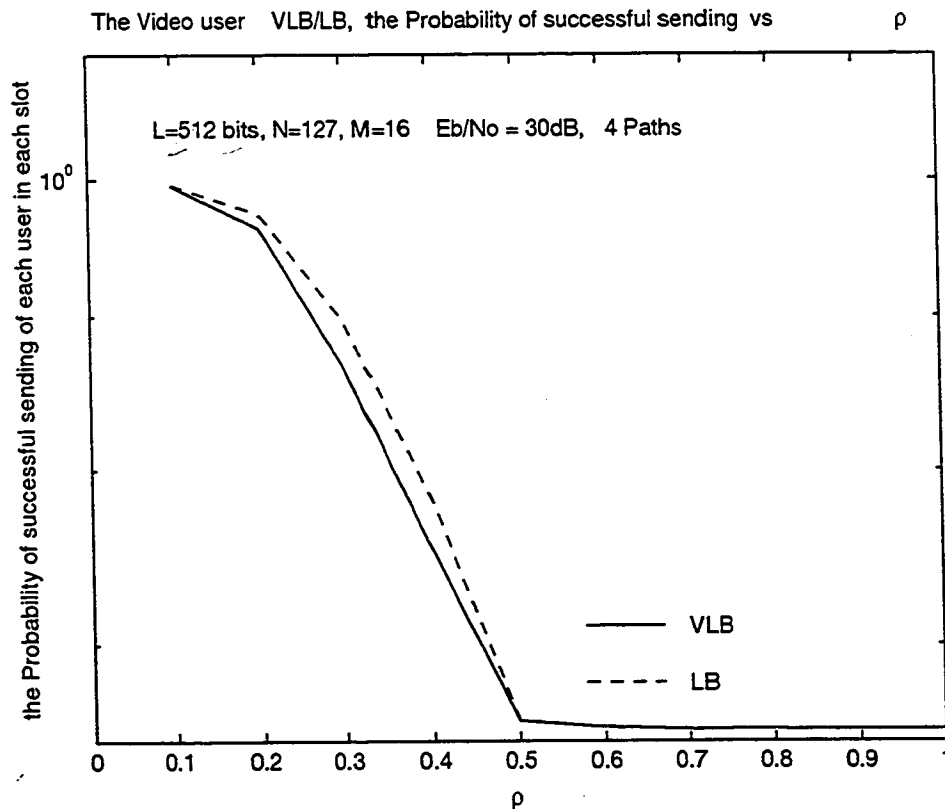

Figure 4.35: the video user's successful sending probability

Fig.4.33 shows the data stream user's discarding function in both LB and VLB. We

assume data stream user is active all the time after his burst. This is a high traffic user group. From the figure, we can see, that after $\rho > 0.5$ two curves become one, since high traffic gives more congestions, that make VLB discard all the marked cells and become the same as LB.

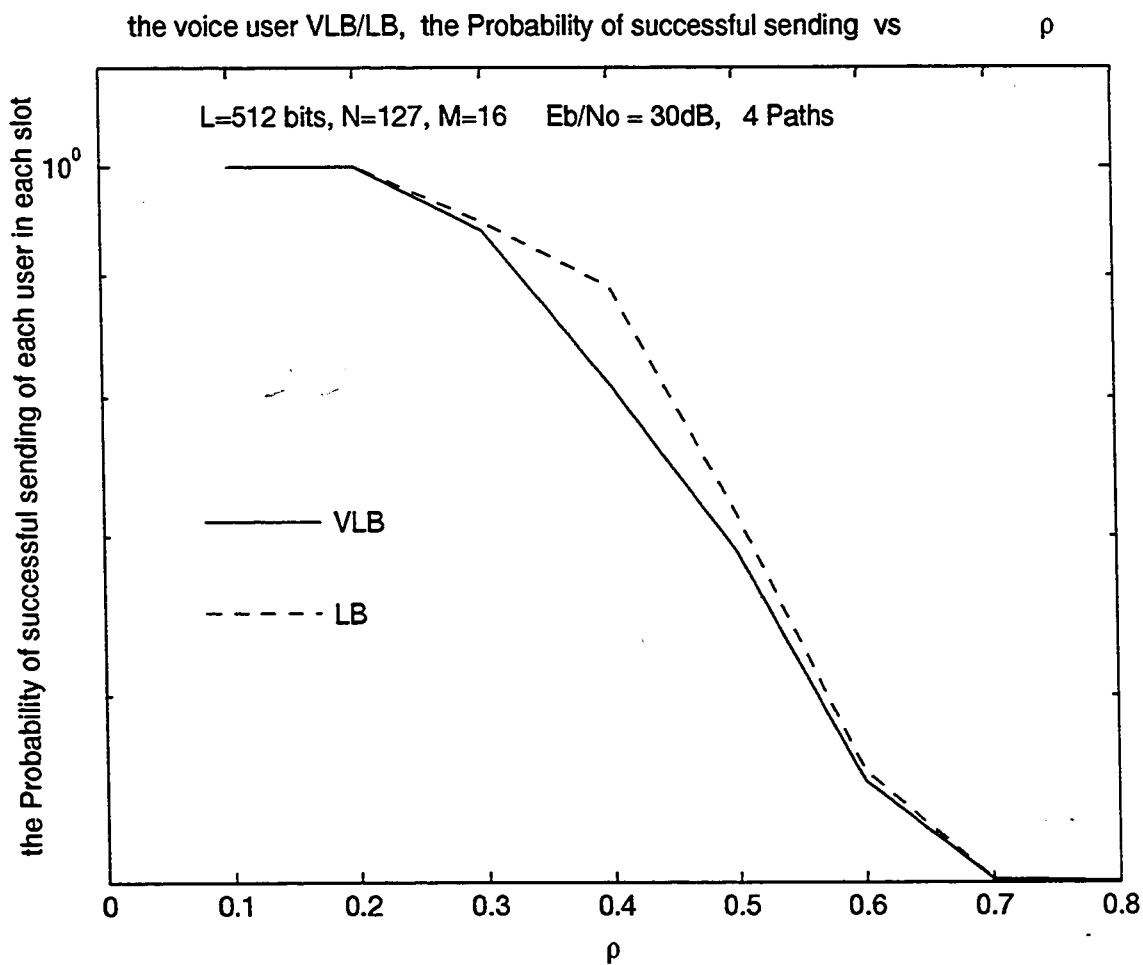

Figure 4.36: the voice user's successful sending probability

From the four figures, we see that the LB discarding function has a small increasing part in the very low traffic range, $\rho < 0.3$. This is because that our traffic sources are

the on/off source, the users standing in the networks are not active all the time. The user from idle state become active state with probability β , and from active state become idle state with probability α , which is shown in the Fig.4.8. In the low traffic range, there are fewer standing users, and from our assumption, we check the active burst at the first slot of each frame only, there are fewer chances to be active burst for fewer standing users.

In Fig.4.34, the increasing part is very small, since the users are the data stream user, their active burst probability is one, in other words, they are always active, there is no random burst effects the flat curve.

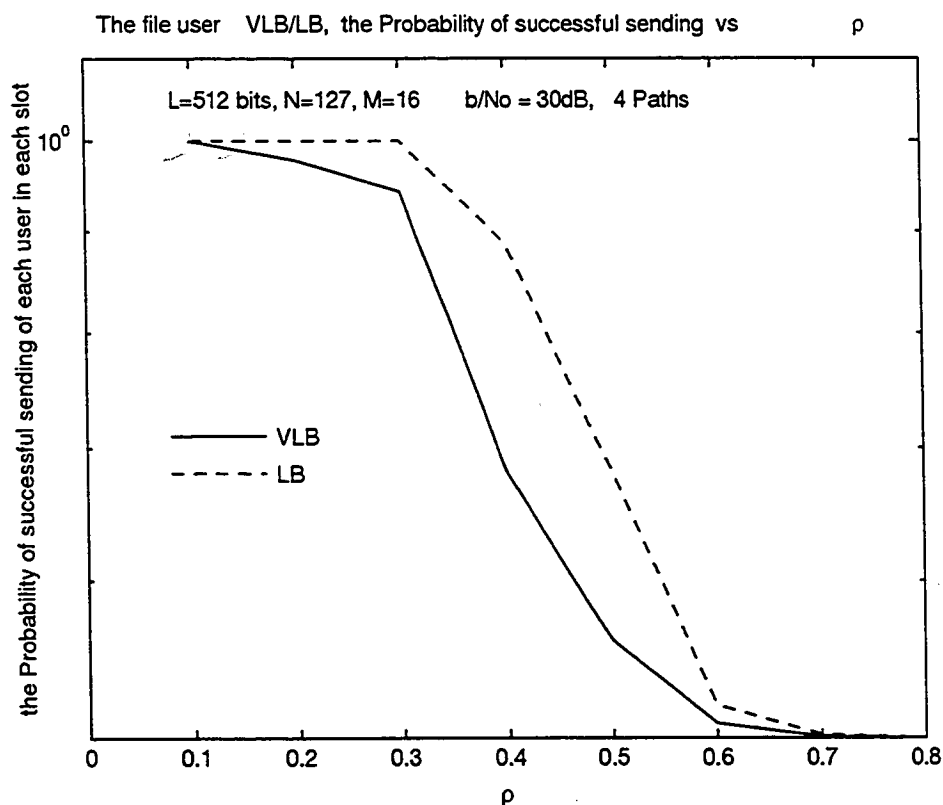

Figure 4.37: the file user's successful sending probability

We calculated the successful sending probability in the simulations. Fig.4.35, Fig.4.36,

Fig.4.37 and Fig.4.38 show the all four group users successful sending probability as a function of the traffic intensity, ρ , under flow control for both leaky bucket scheme and virtual leaky bucket scheme.

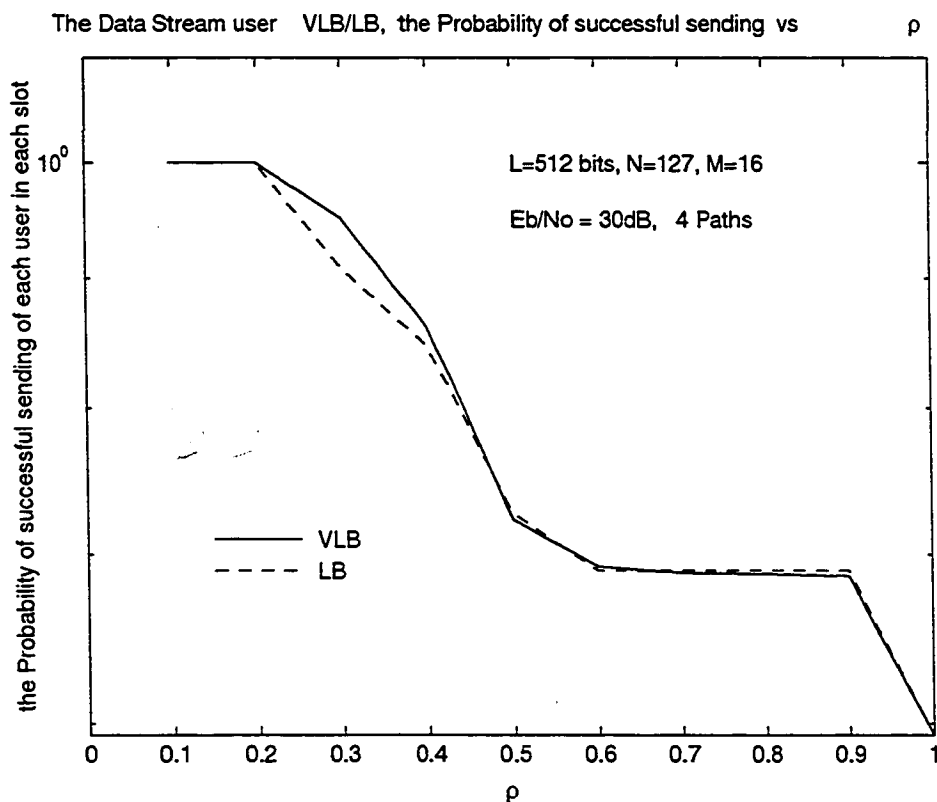

Figure 4.38: the data stream user's successful sending probability

Fig.4.35 shows the video user's successful sending probability function curve. From the figure, we see that the higher the traffic is, the lower the successful probability. and the curve keep flat after $\rho > 0.5$, since there is flow control mechanism. To make bandwidth efficiency higher, we try to keep the successful sending probability more than 50%. For video user, we chopped the extra traffic flow after $\rho > 0.5$. From Fig.4.26, we know that after $\rho > 0.5$, the system delay is shooting away. If there is no flow control, the system

delay may shoot away earlier.

Fig.4.36 shows voice user's successful sending probability function curve. The curve goes down slower than video user, since the voice users have lower traffic than video.

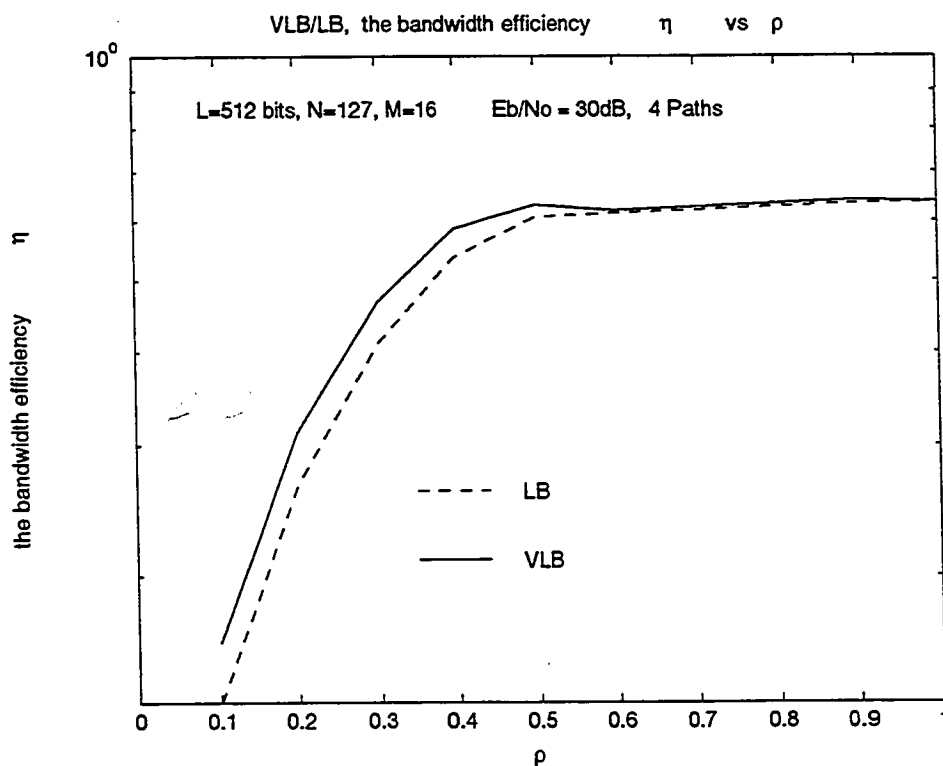

Figure 4.39: the system bandwidth efficiency compared LB/VLB

From the curves, we also see that VLB scheme has worse successful sending probability than LB scheme has, especially in the medium traffic range, this is because VLB has more cells to send when the networks have no congestions. In the lower traffic range, there are no too many cells to be send, so LB and VLB got almost the same successful sending probability. When the traffic is increasing, more cells will be discarded by LB and VLB

will take more extra cells. After certain amount of traffic, there are more congestions in the networks, then VLB become the same as LB.

Fig.4.37 show the file user's successful sending probability function curve. From the curve, we see that VLB's curve is under the LB's curve when $\rho < 0.7$, this means, that VLB works well for file user, VLB can keep more cells from discarding even in the high traffic.

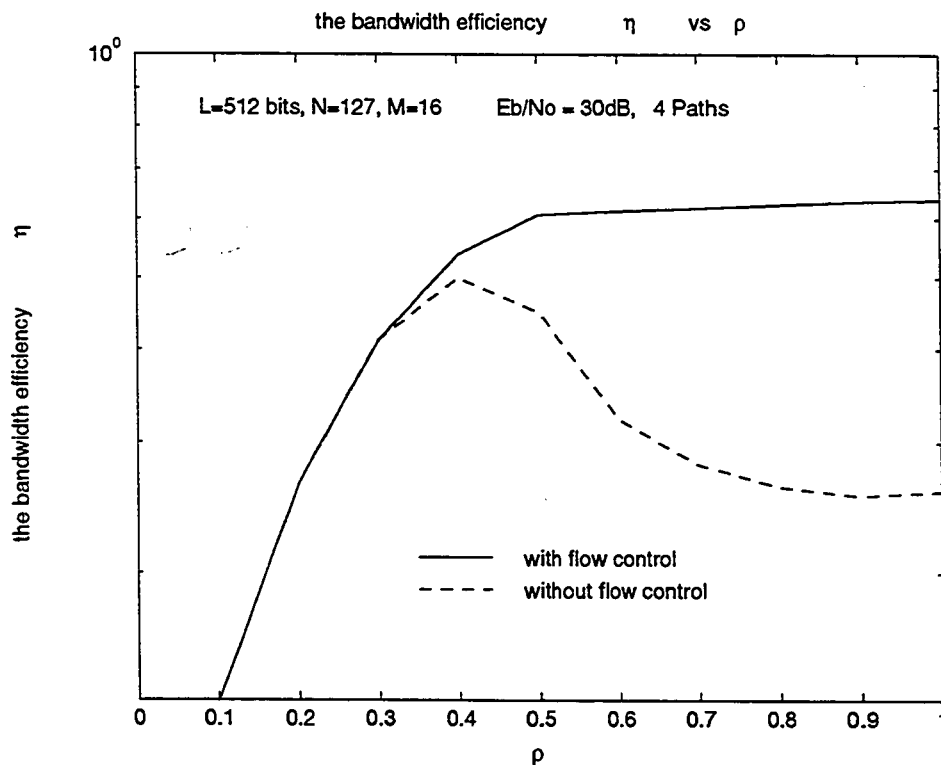

Figure 4.40: the system bandwidth efficiency compared two cases

Fig.4.38 shows the data stream user's successful sending probability function curves. LB and VLB almost the same in this figure, since data stream is a high traffic user, they always generate cells after the burst.

We calculated the bandwidth efficiency of the system in simulations. Fig.4.39 shows the bandwidth efficiency as a function of the traffic intensity, ρ , under flow control for both leaky bucket scheme and virtual leaky bucket scheme. Also, Fig.4.40 shows the bandwidth efficiency as a function of the traffic intensity, ρ , compared with flow control and without flow control for leaky bucket scheme.

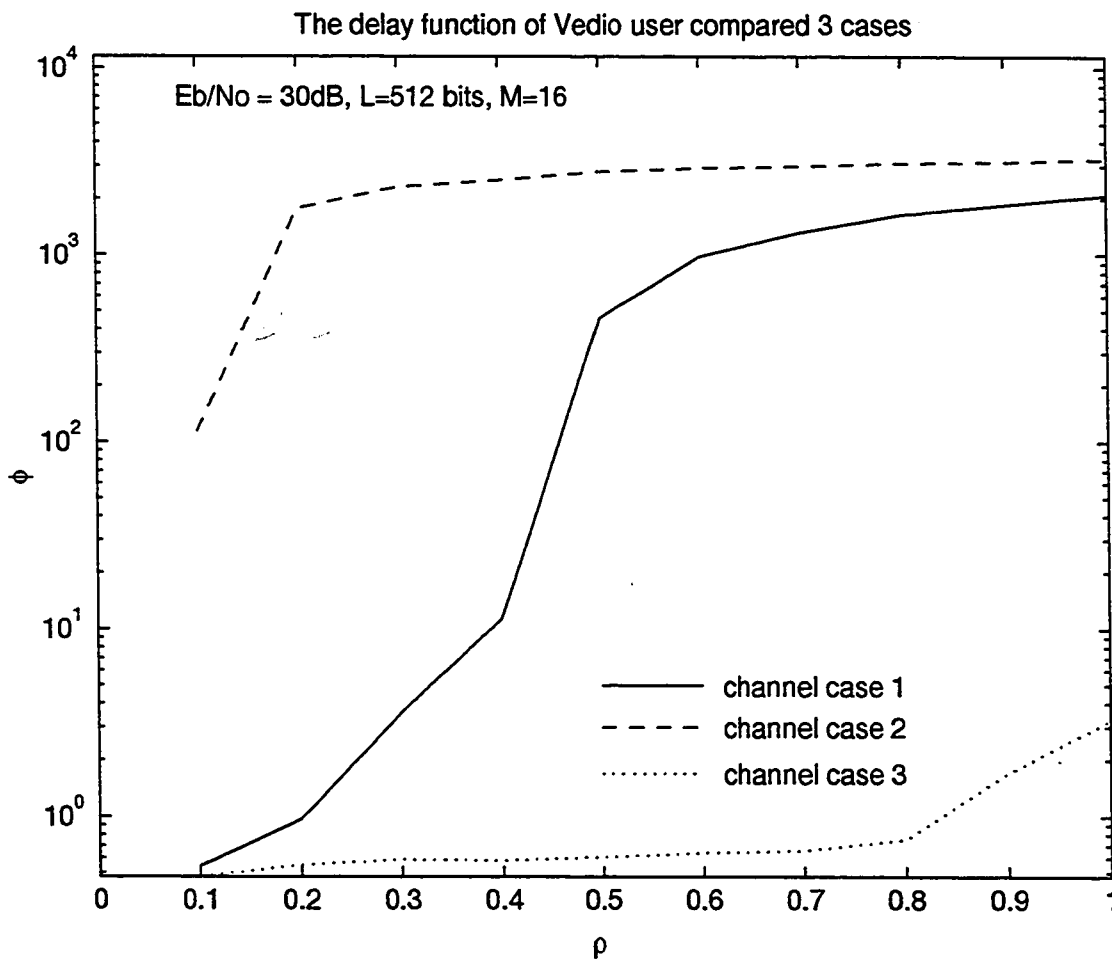

Figure 4.41: the video users' system delay compared 3 cases

From Fig.4.39, the bandwidth efficiency is a flat function after $\rho > .5$, this is

because we took the flow control, to keep a higher successful sending probability and make a good bandwidth efficiency, we chopped the cells which exceed the flow control threshold. From the delay function, we can find that after $\rho > 0.5$, the system delay become huge, if no flow control, after $\rho > 0.5$, delay function will shoot away, since we use non-hub CDMA to serve, without flow control for the high traffic, too many users may send their cells in the same time slot, this will make satellite's successful sending probability too low and failed the sending, that means, the users have to resend their cells, or say makes more delay.

Fig.4.40 shows the bandwidth efficiency of LB compared with flow control and without flow control. The curve without flow control goes down after $\rho > 0.4$, and keep flat after $\rho > 0.7$. Fig.4.41 shows the delay function of video users compared three cases

Bibliography

- [1] IEEE Workshop on Spread Spectrum Potential Commercial Applications, Montobello, Quebec, Canada, May 1991.
- [2] N.Nakagawa and T.Hasegawa, " Spread Spectrum for Consumer Communication Applications of Spread Spectrum Communications in Japan", IEICE Trans., vol.E74, no.5, May 1991
- [3] K.S.Gihousen, I.M.Jakobs, R.Padovina and L.A.Weaver, " Increased capacity using CDMA for mobile satellite communications", IEEE J.Select. Areas Comm.,vol.SAC-8,no.4 May 1990
- [4] M.A.Louay, and J.M.Holtzman, " performance Analysis of DS/CDMA with Noncoherent M-arry orthogonal modulation in multipath fading channel", IEEE J.Select Areas Comm. vol.12 no.5 June 1994
- [5] C.G.Zhang, H.M.Hafez and D.D.Falconer, " Traffic handling capability of a broadband indoor wireless network using CDMA multiple access", IEEE J.Select Areas Comm.vol.12, no.4 May 1994
- [6] P.K.Engel and D.V.Sarwate, " Spread Spectrum Multiple Access performance of orthogonal Codes: Linear receiver", IEEE Trans. Comm. vol.COM-35, no.12, December 1987

- [7] V.M.Dasilva and E.S.Sousa, " Multicarrier Orthogonal CDMA Signals for Quasi-Synchronous Communication System", IEEE J.Select Areas Comm.vol.12 no.5, June 1994
- [8] J.S.Turner, " New direction in communications " IEEE Comm.Mag.vol.25 Otc. 1986
- [9] M.W.Beckner, T.T.Lee and S.E.Minzer, " A protocol and prototype for broadband subscriber access to ISDN's" in Proc. ISS'87 pp B6.3.1-B6.3.8
- [10] I.Cidon and I.S.Gopal, " PARIS: An approach to integrated high speed private networks", Int.J.Digital& Analog Cabled Systems, vol.1, pp.77-86, Apr.-June, 1988
- [11] ITU-T, " Operational and service provisions for future public land mobile telecommunication systems" Draft Recommend. F.115, COM 1-R7, May 1993
- [12] ETSI, " Framework for services to be supported by universal mobile telecommunications system" Draft ETR/SMG-50201, Aug. 1993
- [13] K.Pahlavan and M.Chase, " Spread Spectrum Multiple Access performance of Orthogonal codes for Indoor radio Communications"; IEEE Trans.Comm.vol.38.no.5, May 1990
- [14] H.P.Baer, " Interference effects of hard limiters in PN spread spectrum systems", IEEE Trans.Comm., vol.COM30. May 1982

Chapter 5

The Conclusions

5.1 The Goal of The Thesis

- Develop a new approach to integrate multimediuim services
- Establish an efficient admission rule and cell policing criteria for this new approach
- Find an efficient traffic shaping function for this new approach

For CDMA to be a variable multiaccess approach to integrate multimediuim services over a wide range of constant and variable bit rate server, it is important to come out with suitable admission and congestion control techniques. This is because in CDMA systems user's transmission overlap and large bit error probabilities would result its users violate their average bit rate agreements with satellite. Our work try to minimize the number of ATM/CDMA call overlap by proper traffic control function.

The problem to actually deliver the grade of service that has been promised, and that people are paying good money for. This requires some kind of resource management

strategy, since congestion will be by far the greatest factor in data loss. There are a number of functions that need to be considered and the most important functions are:

- CHARGING FUNCTION
- POLICING FUNCTION
- SHAPING FUNCTION

If the Policing function is the policeman, and the charging function is the judge, then the traffic shaping function is the lawyer.

5.2 The Beneficiaries of CDMA

CDMA's growing acceptance within the mobile communications is due primarily to the fact that its benefits are dramatic and wide ranging. These benefits impact every one from the occasional user to the largest service provider.

The main beneficiaries of CDMA will be the actual users. CDMA is an enabling digital technology that provides enhanced services with higher quality for all customers. Its many user benefits include:

- CDMA increases system capacity, virtually eliminating most busy signals, dropped calls and cross-talk that result from system overcrowding.
- CDMA's digital control channel enables users to access a wide range of new services, including caller identification.

- CDMA handsets typically transmit at power levels 1/25 to 1/1000 those of AMPS and TDMA. These lower power requirements translate into smaller, lighter portable phones with improved talk time and standby time.
- CDMA's spread spectrum signal provides greater coverage than other systems, both indoors and out.
- CDMA improves call quality in congested downtown locations and areas with hilly terrain that experience interference from reflected signals or "multipath."
- CDMA's voice coding technique provides superior voice quality by actively reducing and masking background noise.
- CDMA utilizes a patented method of handling off calls between cells, known as "soft hand-off." This method dramatically reduces the chances of call disruptions during hand-off or of dropped calls due to a failed hand-off.
- A total of 4.4 trillion codes are available to distinguish individual calls, enhancing privacy and eliminating cross-talk.

The costs of providing CDMA services are minimized as follows:

- CDMA reduces the investment in new network facilities. The spread spectrum signal used by CDMA has a much better range than AMPS or TDMA. Because of this improved range, only 1/2 or 1/3 the number of cells are needed to provide the same or improved network coverage. The CDMA cell costs are comparable to those of TDMA, lower than those of AMPS.

- With fewer cells, CDMA networks provide lower operations and maintenance costs.
- CDMA requires none of the ongoing frequency planning needed with alternative systems, further reducing network operating expenses.

Along with the service providers benefits described above, CDMA's 10- to 20- fold capacity increase will provide much needed relief for large service providers in crowded urban areas. This relief can be attained incrementally. By setting aside an initial 15% immediate increase in overall system capacity of up to 190

TDMA would require converting almost the entire spectrum to attain a comparable capacity gain. With CDMA, each additional 10% increases the system capacity by up to twice the capacity of the original analog system.

5.3 CDMA with ATM

The BISDN's fundamental objective is to achieve complete integration of services ranging from low bit rate bursty signals up to broadband continuous real time signals, including voiceband services such as telemetry, data terminal, telephone, facsimile, and broadband services such as video signal transmission. Consequently, an efficient technique for dealing with such a diverse set of services in a generalized manner was desired, and ATM is the technique that was proposed as the solution.

CDMA and ATM have characteristics which separately and in combination can offer significant advantages in the cellular mobile radio and cordless office environments, especially when a wide range of service rates must be carried. Both allow a given transmission link to support a number of simultaneous virtual connections which can be used on demand

and this can simplify routing and reduce overheads. With certain CDMA handoff techniques, the statistical multiplexing properties of ATM enable the most efficient use of the access network. In addition, mobile digital radio techniques, including CDMA, use burst mode transmission resulting in packetization delays. The process of filling ATM cells with speech also involves a packetization delay and the harmonization of mobile radio, and ATM standards result in systems, where the overall delay is less than the sum of the individual delays of the two packetization processes.

In this work we designed the frame structure for CDMA/ATM and CDMA/TDMA/ATM system. The simulation results show that this frame structure works well for the hybrid CDMA/TDMA/ATM system.

5.4 Traffic Policing

The policing function in some way estimates the parameters of the incoming traffic and takes some action if they measure traffic exceeding agreed parameters. This action could be to drop the cells, mark them as being low cell-loss priority, etc.

Most ATM network congestion control approaches fall in class of preventive control. Reactive control does not perform well in ATM networks, because reactive control instructs the source node to shuttle their traffic flow by giving feedback to them, in high speed networks, the feedback may be too late to react effectively.

Preventive controls try to prevent the ATM network from reaching an unacceptable level of congestion. The most common and effective approach is control traffic flow at the access node of the networks. This approach is especially effective in ATM networks because of its connection oriented transport.

Preventive control for ATM can be performed in two ways,

- Admission Control
- Bandwidth Enforcement

In this work we designed the admission rules and cell policing criteria for the CDMA satellite networks. The simulation results show that the admission rules and cell policing criteria works efficiently for the CDMA satellite networks.

5.5 Traffic Shaping

The traffic shaping function uses information about the policing and charging functions in order to change the traffic characteristics of the customer's stream to get the lowest charge or the smallest cell-loss, etc.

Traffic shaping is something that happens in the customer premise equipment. Traffic shaping is forcing the network traffic to confirm to a certain specified behavior. Usually the specified behavior is a worst case or a worst case plus average case. There are a number of parameters and functions that need to be considered for the traffic control.

A variety of techniques have been investigated to implement traffic shaping. Reference the literature for keywords such as "leaky bucket", "congestion", "rate control", and "policing".

In this work we modified the leaky bucket scheme to fit out satellite communications with CDMA channel. The simulation results show that the modified leaky bucket scheme works well for the satellite communication networks.

5.6 Further Work

There is nothing changed in our orthogonal coding modulation technique or our congestion control technique based on cell discarding, that forbids the application to narrowband or broadband satellite channels. Since our technique above are general in nature, however, we have used the probability of bit error which deals with selective multipath fading mobile channels, the treatment of bit errors in this work is general and straight forwardly extended to the broadband selective fading channel cases. Since the paper[3.13] gives values P_b results for a variable number of paths and order of diversity, for the channels with "shadow wink", one needs to change analysis lightly. Also, for flat fading cases, the same paper[3.13] contains corresponding bit error result which can be used.

Moreover, the exact fading mode for the wideband Ku satellite channel is not fully formatted yet. In the near future, we plan to extend our results to this case. Basically, The bit error analysis of our CDMA orthogonal system has to be evaluated by analysis or simulations, this will be followed by repeated simulations for our new congestion control and admission rules. These items are the main concern of research. There is nothing in our new congestion control and admission rules that forbid the applications to the wideband satellite channel, our emphasis is basically on those networking aspects.