

**Framework for Integrating Bridge Inspection Data with
Bridge Information Model**

Danial Ghadiri Moghaddam

A Thesis

in

Concordia Institute for
Information Systems Engineering

Presented in Partial Fulfillment of the Requirements
for the Degree of Master of Applied Science (Quality Systems Engineering)
at

Concordia University
Montreal, Quebec, Canada

May 2014

© Danial Ghadiri Moghaddam

CONCORDIA UNIVERSITY

School of Graduate Studies

This is to certify that the thesis prepared

By: **Danial Ghadiri Moghaddam**

Entitled: **Framework for Integrating Bridge Inspection Data with Bridge Information Model**

and submitted in partial fulfillment of the requirement for the degree of

Master of Applied Science (Quality Systems Engineering)

complied with the regulations of the University and meets with the accepted standards with respect to originality and quality.

Signed by the final examining committee:

Dr. Y. Zeng Chair

Dr. A. Schiffauerova Examiner

Dr. Z. Zhu Examiner

Dr. A. Hammad Supervisor

Approved by Dr. C. Assi

Chair of Department or Graduate Program Director

May 2nd, 2014

Date

Dean of Faculty

ABSTRACT

Framework for Integrating Bridge Inspection Data with Bridge Information Model

Danial Ghadiri Moghaddam

The collapse of Silver Bridge, Virginia, U.S. in 1967 was a shock to the public awareness about the danger of deteriorating infrastructures which alerted about the necessity of better inspection programs. In practice, inspection data are being often collected on paper as textual data and this inspection process has various consequences including difficulties in data sharing, errors in communication among various stakeholders involved in the project and information losses. Recently, bridge data sharing and integration became of a significant importance due to the fragmented nature of bridge Operation and Maintenance (O&M) activities. A framework is proposed in this research to extend the usability of Bridge Information Modeling (BrIM) into the O&M phase. The framework proposes the improvement of bridge O&M processes with a focus on bridge inspection by improving the processes of documentation, data storage and information visualization. Inspection observations are added to the BrIM by direct interaction of the inspector with the model at the inspection site. Moreover, by adding the time dimension to the BrIM, the 4D visualization of modeled defects enables defect propagation monitoring. The proposed method extends the Industry Foundation Classes (IFC) standard as a communication language among the stakeholders involved in the lifecycle management of a bridge. Various defect-related definitions and properties are identified and added to the IFC. A

case study is implemented and tested in order to evaluate the proposed method and explore its technical feasibility.

ACNOWLEDGEMENTS

My greatest appreciation goes to my supervisor, Prof. Amin Hammad for his intellectual and personal support, encouragement and patience. His advice and criticism were my most valuable asset during my studies.

I would like to appreciate the help of Mr. Bryan Wai from Alberta Ministry of Transportation for providing required data of bridge inspections.

I would like also to thank my lab mates who made the lab a friendly environment for working together, specially my friends Mr. Farid Vahdatikhaki, Dr. Ali Motamedi, Mr. Shayan Setayeshgar, Mr. Moahamad Soltani who have helped, supported and criticized me in my research.

Special thanks are owed to my parents: Dr. Abolfazl Ghadiri Moghaddam and Fatemeh Akbarzade, for their endless support throughout my life, their faith in me and allowing me to be as ambitious as I wanted. It was under their watchful eye that I gained so much drive and the ability to tackle challenges.

TABLE OF CONTENTS

List of Figures	ix
List of Tables	xi
List of Abbreviations	xii
CHAPTER 1 INTRODUCTION.....	1
1.1 Background and problem statement.....	1
1.2 Research objectives	3
1.3 Thesis organization	4
CHAPTER 2 LITERATURE REVIEW.....	6
2.1 Introduction	6
2.2 Bridge Management Systems.....	6
2.3 Bridge Operation and Maintenance.....	10
2.3.1 Necessity of bridge maintenance	10
2.3.2 Bridge inspection	12
2.3.3 Common defect types of concrete bridges.....	18
2.3.4 Common practices of concrete partial/non-destructive testing.....	20
2.4 Bridge and Building Information Modeling.....	23
2.4.1 Building Information Modeling.....	24
2.4.2 Bridge Information Modeling.....	26
2.4.3 IFC model	29
2.4.4 IFC-Bridge	33
2.5 4D visualization of inspection data	34
2.6 Summary	36

CHAPTER 3	PROPOSED APPROACH	37
3.1	Introduction	37
3.2	Proposed framework for BrIM-lifecycle data integration.....	39
3.3	BrIM-Inspection data integration approach	44
3.4	Defect modeling	47
3.5	Inspection data interaction model	49
3.5.1	Inspection information capture methods.....	55
3.6	Extension model for inspection data incorporation in BrIM.....	55
3.6.1	Necessity of incorporating inspection data definitions in BrIM.....	56
3.6.2	Inspection data structure	57
3.6.3	Requirement assessment and extension processes for inspection data definitions	58
3.6.4	<i>IFC-Defect</i>	59
3.6.5	<i>IFC-Defect</i> properties definition.....	61
3.7	4D visualization of inspection data	64
3.8	Summary and conclusions.....	65
CHAPTER 4	IMPLEMENTATION AND CASE STUDY	66
4.1	Introduction	66
4.2	Implementation.....	66
4.3	Defect model development.....	68
4.4	BrIM model update with inspection information.....	74
4.5	4D visualization of defect propagation	77
4.6	GIS integration with BrIM	78
4.7	IFC extension: Relationship definition using Express language.....	81

4.8	Summary and conclusions.....	83
CHAPTER 5 CONCLUSIONS AND FUTURE WORK		85
5.1	Summary of research.....	85
5.2	Research conclusions	86
5.3	Limitations and future work.....	87
REFERENCES		88
Appendix 1	Sample of the modeled bridge inspection reports	98
Appendix 2	Sample of AT inspection report coding	109
Appendix 3	Sample of bridge drawings.....	110
Appendix 4	Table of concrete bridge defects and their potential occurrence location	112

LIST OF FIGURES

Figure 2-1 Basic BMS modules (Ryall, 2010).....	8
Figure 2-2 Two approaches in BMSs (Small et al., 2008).....	8
Figure 2-3 Qualitative deterioration–time relationship for various levels of maintenance (Mirza, 2006)	11
Figure 2-4 S-N curve for plain concrete subjected to reversed flexural loading (Murdock, 1965)	12
Figure 2-5 Inspection and assessment processes (Helmerich et al., 2008).....	18
Figure 2-6 Common defects of concrete structures (BIM reference manual, 2007; BIRM, 2012)	20
Figure 2-7 (a) Automated scanning of a box girder slab by Ultrasonic Echo testing method, (b) Visualization of tendon ducts in the slab in a depth of 150 mm parallel to the surface (Helmerich et al., 2008).....	23
Figure 2-8 Centralized data model supporting integrated process (Sacks, 2002).....	28
Figure 2-9 The overall architecture of the IFC model (IFC, 2013)	32
Figure 2-10 Bridge spatial structure components (IFC for Roads, 2013).....	34
Figure 2-11 Color coding visualization of HVAC model during the maintenance phase (Hammad and Motamedi, 2007)	35
Figure 3-1 Framework for BrIM-lifecycle data integration (adapted from Hammad et al., 2013)	43
Figure 3-2 Conceptual interaction system	45

Figure 3-3 Example of predefined spalling defect model (a) and its application on a precast box girder (b)	46
Figure 3-4 Example of a typical crack model (a) and the pertinent properties (b).....	48
Figure 3-5 Comparison of the conventional method versus proposed method of data integration	51
Figure 3-6 Proposed IFC hierarchy for IFC-Defect.....	60
Figure 4-1 Process flow of Alberta Infrastructure and Transportation database update ..	69
Figure 4-2 (a) Element hierarchy of the Autodesk Revit, (b) Hierarchy of the proposed families (Adapted from Autodesk, 2014)	70
Figure 4-3 Class and Subclass of the proposed predefined defect families, (Adapted from Autodesk, 2014).....	71
Figure 4-4 Adaptive defect models in family editor interface before adaption and assigned properties developed in project interface	75
Figure 4-5 3D view of the modeled bridge.....	76
Figure 4-6 Integration of bridge O&M data with BrIM	76
Figure 4-7 4D visualization of defect propagation by using linked time dimension to defect models	78
Figure 4-8 Export process of all Revit elements in the bridge model to the map.....	80
Figure 4-9 Geo-referenced BrIM model published on Google Earth map	80
Figure 4-10 Representation of void relationship between delamination and pier in DDS-CAD Open BIM viewer	83

LIST OF TABLES

Table 2-1 Comparison of the BMSs at different provinces and territories in Canada (Yan, 2008)	9
Table 2-2 Width-based crack categorization in concrete (BIM reference manual, 2007)	19
Table 2-3 Comparison of concrete NDT methods, adapted from (McCann et al., 2001)	22
Table 2-4 3D documentation processes versus 2D drawings (Chen et al., 2006)	29
Table 3-1 Condition rating system (BIM Inspection Manual, 2008).....	58
Table 3-2 Shared property sets for IFC-Defect.....	61
Table 3-3 Defined properties of defects for IFC-Defect.....	62
Table 4-1 Review of embedded behavior and attributes of family templates (Autodesk, 2014).....	72
Table 4-2 EXPRESS code for the model.....	82

LIST OF ABBREVIATIONS

Abbreviation	Description
3D	Three-dimensional
4D	Four-dimensional
AASHTO	American Association of State Highway and Transportation Officials
AECOO	Architecture, Engineering, Construction, Owners, and Operators
AI	Artificial Intelligence
AT	Alberta Transportation
API0	Application Programming Interfaces
BIM	Building Information Model
BIM ₂	Bridge Inspection and Maintenance System
BIS	Bridge Information System
BMS	Bridge Management System
BrIM	Bridge Information Modeling
BSA	BuildingSMART Alliance
bSDD	building SMART Data Dictionary
CAD	Computer-Aided Design
CCTV	Close-Circuit Television
CHL ₂	Chloride Testing
CIS	Culvert Inventory System
CNC	Computer Numerical Control
CSE	Copper Sulfate Electrode
FHWA	Federal Highway Administration
GDP	Gross Domestic Product
GIS	Geographic Information System
GPR	Ground-Penetrating Radar
GPS	Global Positioning System
IAI	International Alliance of Interoperability

IFC	Industry Foundation Classes
IFD	International Framework for Dictionaries
ISO	International Standards Organization
LiDAR	Light Detection and Ranging
NBIS	National Bridge Inspection Standards
NDT	Non-Destructive Testing
O&M	Operation and Maintenance
RFID	Radio Frequency Identification
SGML	Standard Generalized Markup Language
SI&A	Structure Inventory and Appraisal data
STEP	STandard for the Exchange of Product model data
UWB	Ultra-Wideband
XML	Extensible Markup Language

CHAPTER 1 INTRODUCTION

1.1 BACKGROUND AND PROBLEM STATEMENT

Transportation bears a vital responsibility for the economic prosperity of each nation and the safety of the users. Bisby (2004) revealed the fact that 40% of in-service bridges in Canada are aged 50 or more. Given the budget deficit alongside the existing maintenance backlog of infrastructures, the importance of process improvement in Operation and Maintenance (O&M) becomes of a significant importance (Mayes et al., 1992; Gagnon et al., 2008; Industry Canada, 2013). The collapse of Silver Bridge, Virginia, U.S. in 1967 was a shock to the public awareness about the danger of deteriorating infrastructures which alerted to the necessity of improving ongoing inspection programs (Silano, 1992).

Bridge inspection has evolved through decades. In the U.S., National Bridge Inspection Standards (NBIS) were established in 1971 with the role of providing unified standards and guidelines including standardized inspection methods, inspection intervals and inspector qualification. However the effort of a national Canadian standard for bridge inspection is yet to succeed (Minor et al., 1992). Bridge management is the means of conserving the bridge investment all through its lifecycle, from the conception phase to its demolition (Frangopol et al., 2001). Bridge Management Systems (BMSs) are highly dependent on the bridge inspection information which is gathered on site by the inspector (OAGO, 2009). Various BMSs of different provinces in Canada recall the evident need for a unified national BMS. However, since there is no standard BMS in Canada and

most other countries, it is clear that data sharing and integration are of a significant importance.

Traditional bridge design and construction have been highly relying on paper-drawings as primary construction documents and paper reports or textual data as the way of data exchange among various domains involved in a project. Besides, in practice, often O&M data are being collected on paper as textual data. Even though being digitized and processed as information, the available information is fragmented to different stakeholders who collect different types of O&M data. The conventional textual inspection reports have various consequences including difficulties in data sharing, errors in communication among various domains involved in the project and information losses within the same domain. Also, due to interoperability obstacles, redundant data entering reaches to seven times before the construction project completion (Sjogren and Kvarsvik, 2007).

In spite of the fact that the 3D design of bridges is becoming popular, the bridge industry does not leverage a core digital 3D product model in practice. The lack of a centric information model in this industry causes obstacles for a streamlined and on-time product delivery, increased cost and time of data exchange and low quality induced by error-prone data exchange methods (Chen et al., 2006). Other close industries leverage the 3D data model across the lifecycle of their products and have experienced added efficiency thereby (Khanzode and Fischer, 2000). Thus, due to the existing gap among the various stages and stakeholders in the lifecycle of a bridge, a cross-phase, cross-layer information

exchange becomes inevitable which can be achieved by a centric object-oriented information model.

This research has observed the following problems in the management of highway bridges: (1) Neglected usage of BrIM through the O&M of bridges and limiting its usage to the design and construction phases; (2) Manual inspection documentation and redundant data management processes for bridge management database update; (3) Disconnected project level and network level bridge management; and (4) Interoperability and extensibility issues for data sharing and exchange among various phases and domains involved in the bridge management.

1.2 RESEARCH OBJECTIVES

This research aims to propose a framework to extend the usability of Bridge Information Modeling (BrIM) into the O&M phase (Chen et al., 2006). Thus, the proposed method deals with three distinctive goals and their pertinent implementation issues (i.e. feasibility, interoperability and extensibility):

(1) Improving the bridge O&M processes with a focus on bridge inspection by improving the process documentation, data storage and information visualization. This research suggests adding inspection observations to the BrIM by facilitating the interaction of the inspector with the BrIM at the inspection site. Moreover the 4D visualization of defect propagation based on inspection data becomes possible benefiting from the linkage of the time dimension and the BrIM inspection information.

(2) Extending Industry Foundation Classes (IFC) (IFC, 2013) as a communication language among a large number of stakeholders involved in the lifecycle management of a bridge in order to provide the data structure which is required to host lifecycle management information. Various defect-related definitions and properties are identified and proposed in IFC as a necessary part of the extension process.

(3) Integrating the BrIM with Geographic Information System (GIS) to enhance bridge lifecycle management processes of the network-level.

1.3 THESIS ORGANIZATION

This thesis will be presented as follows:

Chapter 2 Literature Review: This chapter covers current practices of both project level and network-level bridge management as well as the emerging technologies and new researches in the aforementioned areas. Also, various standards are reviewed in support of our research.

Chapter 3 Proposed Approach: In this chapter the proposed framework for BrIM-lifecycle data integration is proposed and the BrIM-inspection data integration approach is elaborated. The proposed method of adding the 3D model of structural defects from inspection observations as information objects to the BrIM is explained in detail. Furthermore, 4D visualization of inspection data is proposed. Eventually, the IFC extension is proposed and various defect-related definitions and properties are identified and proposed in IFC architecture.

Chapter 4 Implementation and Case Study: In this chapter, the proposed approach is validated through a case study implemented on the design and inspection data of an overpass in Alberta. In order to implement the proposed method, the required defect models are developed and their properties are defined. Later, the BrIM model of the bridge is modeled and integrated with the inspection data. Besides, in order to validate the 4D visualization of inspection data, the date of inspection is added as the time dimension to the defect models and the required modifications are implemented to visualize the propagation of defects on the BrIM. Additionally, the 3D model of the bridge is geo-referenced and placed on the map to facilitate the network-level processes of the bridge management. Furthermore, the IFC model of the BrIM is created and the Express codes pertinent to the proposed extension are added to this model.

Chapter 5 Conclusions and Future Work: This chapter summarizes the present research work, highlights its contributions, and suggests recommendations for future research.

CHAPTER 2 LITERATURE REVIEW

2.1 INTRODUCTION

This chapter covers current practices of both project level and network-level bridge management as well as the emerging technologies and new researches in the aforementioned areas. Also, various standards were reviewed in support of the current research. The goal is to study the current practices, investigate the shortcomings and explore the new technologies, researches and their provided solutions, which enables us to view the existing drawbacks and leads us to an informed exploration for new improvements. Moreover, the upcoming trend of new technology development is discussed based on futuristic visions and forecasts of research and industry leads.

The literature review comprises the bridge management practices and bridge O&M with a focus on bridge inspection. Information modeling in building and bridge industries is reviewed and the standardization efforts are briefly introduced. Eventually, 4D visualization of defect propagation based on inspection data is briefly reviewed and the emerging trends are studied.

2.2 BRIDGE MANAGEMENT SYSTEMS

As the complexity of bridge structures has dramatically increased, the notion of BMS also evolved from primitive card index systems to the state-of-the-art computer based systems (Thompson et al., 1998). Bridge management is the means of conserving the bridge investment all through its lifecycle; from the conception phase to its demolition.

Unfortunately, the legacy of a huge maintenance backlog of existing bridges is the result of forward planning deferral in the early phases of bridge construction (Frangopol et al., 2001). However, in recent practice, bridge management involves bridge O&M activities including inventory data collection and verification, various types of inspection, condition assessment, budget allocation, maintenance or rehabilitation and safety issues. Every BMS is comprised of the following basic data modules: (1) Inventory module stores the permanent characteristics like location and construction data. (2) Inspection module deals with the inspection observation data from inspection reports and condition rating of bridge component components. (3) Maintenance module stores a variety of data about the maintenance choices and the carried out maintenance. (4) Cost module deals with financial records and consequences of fund prioritizing. (5) Condition module deals with the rating of the bridge condition based on the inspection information and expected service level of the bridge. As Figure 2-1 illustrates, these components are centered around a database, forming a system which is capable of analysis based on the provided information (Ryall, 2010).

BrM (formerly Pontis) software is an example of top-down approach which is a network-level BMS developed by Federal Highway Administration (FHWA) in U.S BrM software allows data analysis in order to obtain optimal network-level decisions. In the bottom-up approach, project planning should comply with standards. Then, the sum of the projects costs identifies the costs which would be compared with the budget. This approach is more common in planning and standardization studies and plan adjustments. Bridgit BMS which is developed by American Association of State Highway and Transportation

Officials (AASHTO) provides the project level decision analyses. This approach enables prioritizing the project level alternative strategies (Wolfgram, 2005).

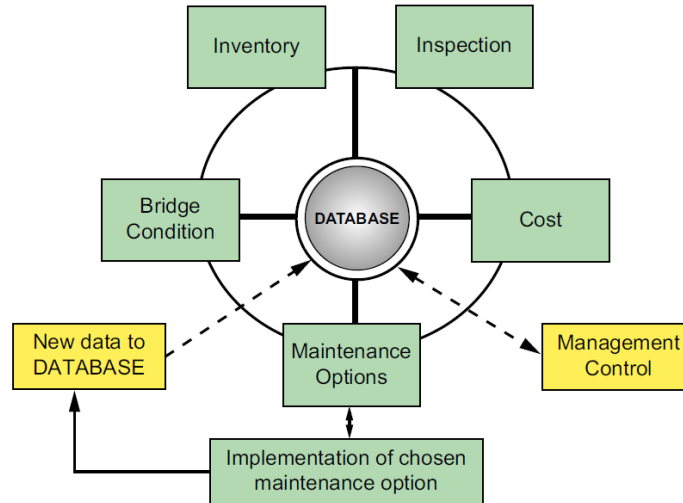

Figure 2-1 Basic BMS modules (Ryall, 2010)

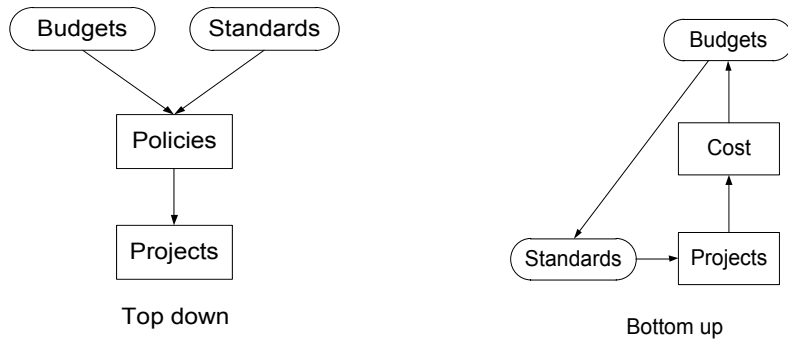

Figure 2-2 Two approaches in BMSs (Small et al., 2008)

BMS in Canada

Based on Lounis, (2008) there are about 80,000 bridges in Canada. However, not all of them are considered in BMSs since even the definition of a bridge to be considered in BMSs varies from province to province in Canada (Khanzoda, 2000). Despite the need for a unified and integrated BMS in Canada, the efforts have not led into a strong enough will for the unification of Canada BMSs. There are provinces in Canada without an

advanced BMS, also, the differences between the data architecture of various BMSs in Canada result in deferent outputs and reduces the potential of integration and network-level application of BMSs (Thompson et al., 1999). Table 2-1 provides a clear view about the state of BMS in various provinces in Canada and recalls the evident need for a unified national BMS. Since there is no national BMS in Canada, It is clear that the data sharing and integration became of a significant importance.

Table 2-1 Comparison of the BMSs at different provinces and territories in Canada (Yan, 2008)

Province	No. of Bridges P: Provincial M: Municipal	State of Development of BMS	BMS	Condit ion Rating System	Distribution by Material Type	Agency Responsible of BMS
British Columbia	20,000	Started in 1986 Rebuild in 2000	BMIS	5	N.A.	Ministry of Transportation
Alberta	9,800 (M) 4,100 (P)	Early 1970s to 2002	BEADS	9	N.A.	Department of Infrastructure and Transportation
Saskatchewan	820 (P) 2200 (M)	N.A.	N.A	4	N.A	Department of Highways and Infrastructure
Manitoba	1200 (P)	N.A.	Pontis	5	N.A.	Department of Infrastructure and Transportation
Ontario	2620 (P) 12000 (M)	1989-1999	OBMS	4	N.A.	Ministry of Transportation
Quebec	4300 (P) 4400 (M)	Finished 2007	QBMS	5	Timber: 0.3% Concrete: 75.8% Steel: 16.7% Other: 7.2%	Ministry of Transportation
New Brunswick	N.A.	N.A.	N.A.	N.A	N.A.	Department of Transportation
Nova Scotia	4000 (P)	1999-2003	NSBMS	4	Timber: 60% Concrete: 20% Steel: 20%	Department of Transportation and Public Works
Prince Edward Island	200	Ongoing	PEIBMS	4	Timber: 50% Concrete: 25% Steel: 25%	Department of Transportation and Public Works
Newfoundland and Labrador	N.A.	N.A.	N.A.	N.A.	N.A.	Department of Transportation

2.3 BRIDGE OPERATION AND MAINTENANCE

2.3.1 NECESSITY OF BRIDGE MAINTENANCE

Transportation bears a vital responsibility in economic flourish of each nation. Based on Statistics Canada (2013) report, in 2012 transportation and warehousing contributed 64,896 millions of chained dollars (2007) at basic prices to the Gross Domestic Product (GDP) which equals to 4.16% of total industry GDP. 27% of transportation and warehousing contribution belongs to truck transportation. Thus, highway bridges serve an undeniable and critical role in the transportation system of Canada.

Given that 40% of in-service bridges in Canada are aged 50 or more (Bisby, 2004), 19% increase in transportation and warehousing GDP between 2002 and 2011 in Canada (Industry Canada, 2013) does not give a major credit to O&M condition of transportation systems, because only 20% of the investment in this section is absorbed by maintenance and restoration of transportation systems and 80% of the remaining budget is spent for new constructions of infrastructures (Gagnon et al., 2008) and obviously there is a budget deficit for maintaining the transportation systems.

Figure 2-1 represents the deterioration of Canada's infrastructure with respect to the conducted level of maintenance. This study clearly explains that the lack of maintenance and rehabilitation is proportional to the deterioration of infrastructure (Mirza, 2006). Allocating 2% of construction costs to maintenance of an infrastructure not only assists in maintaining a high level of performance, but also increases the anticipated service life.

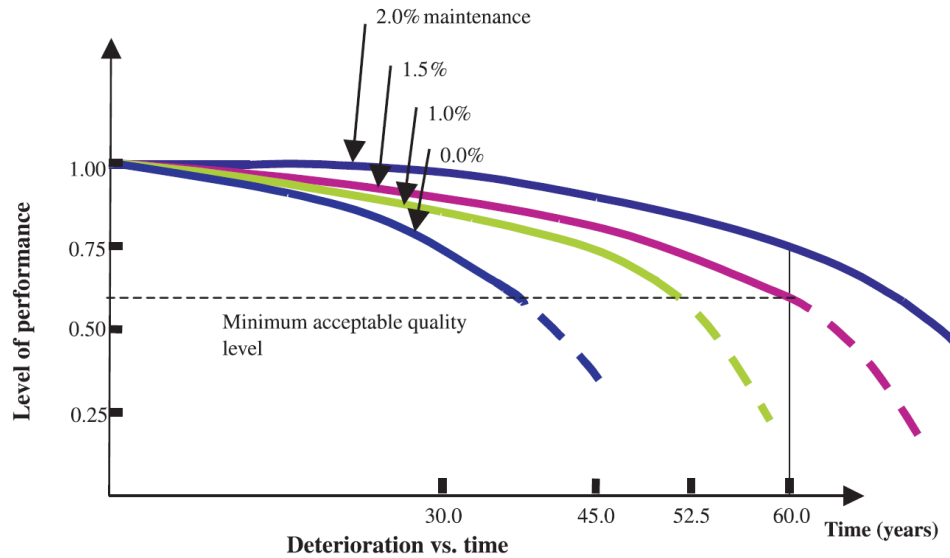

Figure 2-3 Qualitative deterioration–time relationship for various levels of maintenance (Mirza, 2006)

Moreover, Bridge structures may have to undertake unexpected loads of natural disasters or extra-load of heavy vehicles apart from usual road system loads. Mayes et al. (1992) remarks that “*The collapse of a highway bridge during an earthquake will in many cases sever vital transportation routes at a time when they are most needed*”. Apart from that, dynamic wheel load of a heavy-goods vehicle imposed on highway bridges causes vibration in the same range of frequencies as the natural frequencies of bridges. Consequently, the excitation phenomenon would be significant which may lead to critical amplification of the structure vibration and the collapse of the structure (Green et al., 1994). Although the fatigue phenomenon is well-known in steel material, concrete strength reduction under cyclic loading is substantial in concrete as well. As Figure 2-4 shows, cyclic loading undertaken by concrete substantially decreases its ultimate flexural strength; this deficit has to be compensated by a higher factor of safety in design

(Murdock, 1965). Thus, bridge structures are more susceptible to deterioration compared to buildings or other types of infrastructures due to imposed dynamic loads and vibrations.

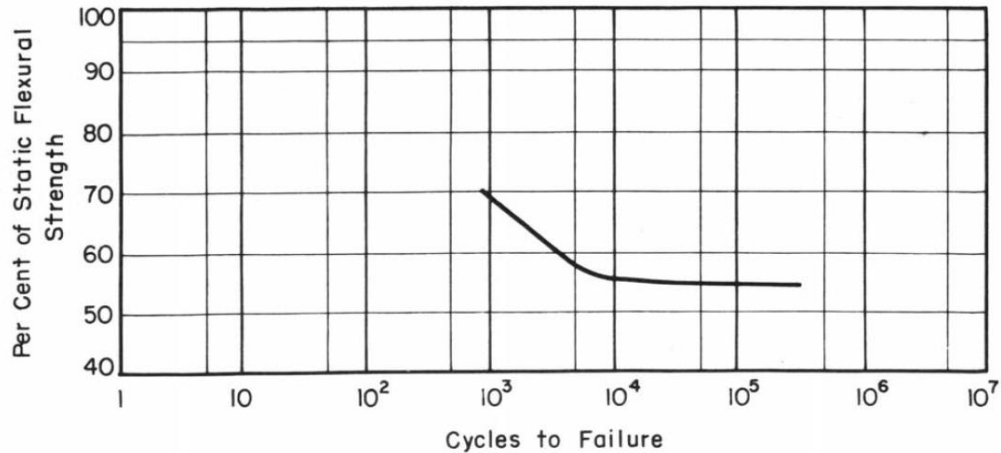

Figure 2-4 S-N curve for plain concrete subjected to reversed flexural loading (Murdock, 1965)

2.3.2 BRIDGE INSPECTION

The collapse of Silver Bridge, Virginia, U.S. in 1967 was a shock to the public awareness about the danger of deteriorating infrastructures which aroused the necessity of current ongoing inspection programs. Other types of bridges like railroad and transit bridges bear the same deterioration situation. Since a huge backlog of rehabilitation and reconstruction works was considered necessary for the deteriorating infrastructures, the FHWA decided to rate the bridges based on their biennial inspection results in order to prioritize the O&M activities and budgets (Silano, 1993). Three objectives for bridge inspection can be enumerated as the following: (1) Bridge inspection tends to ensure the safe condition of the bridge; (2) It assists in identifying the necessary O&M acts including maintenance,

repair, rehabilitation and reconstruction; (3) It provides the basic data for maintenance planning and budget allocation (OAGO, 2009).

Bridge inspection has evolved through decades. In the U.S., National Bridge Inspection Standards (NBIS) were established in 1971 with the role of providing unified standards and guidelines including standardized inspection methods, inspection intervals and inspector qualification. However the effort of a national Canadian standard for bridge inspection is yet to succeed. Inspection interval for the detailed inspection of surface transportation bridges is two years; however, occasional inspection pertinent to problematic areas may be scheduled in shorter intervals (Minor et al., 1992).

Minor et al. (1992) categorizes the bridge inspection types into five categories, namely: Inventory inspection, Routine inspection, Damage inspection, In-depth inspection and Interim inspection. (1) Inventory inspection is done as the first inspection of an in-service bridge after its construction phase; however, it has to be conducted after any change in the configuration of the bridge structure. (2) Routine inspection is considered as a scheduled intermediate level inspection which specifies the “health” situation of the bridge by leveraging the rating system through the use of proper observation and measurements. These periodic inspections allow the inspector to track the propagation of defects. NBIS specified inspection personnel qualification and Structure Inventory and Appraisal data (SI&A) update as a part of this inspection type. (3) Damage inspection tends to assess the necessity of urgent bridge load restriction or bridge closure as well as an urgent repair action in case of unexpected structural damages. (4) In-depth inspection investigates specific components of bridge which are of ultra-importance or the ones that

are susceptible to defects. Nondestructive inspection and underwater inspection are considered as subcategories of in-depth inspection. Usually the members which are subject to in-depth inspection cannot be properly inspected in routine inspections. (5) Interim inspection can be defined as a defect specific inspection (e.g., a skilled inspector who investigates the nature and causes of concrete crack) which should be scheduled at the discretion of the inspection responsible authorities.

In Europe the context of bridge inspection is different due to plenty of historical serviceable infrastructures as well as baring a nation-specific construction process in each nation. Network-level bridge inspection in Europe aims to ensure structural reliability as well as serviceability which assess the situation of the structure under the expected traffic load. France recently uses a flexible railway bridge inspection intervals based on the criticality of the infrastructure to public users and the owners (Helmerich et al., 2008). German Highway Administration has developed a sophisticated bridge management system in comparison with other European countries, which integrates multiple databases including a database of drawings, a database of typical defects, a database of deviation from required parameters for condition assessment, and a defect-specific Non-Destructive Testing (NDT) method database. Besides they developed a unique defect evaluation system based on three distinct factors, namely, structural safety, traffic safety and durability, which allow more case-sensitive assessments. It is worth mentioning that the system developers attempted to include all possible defect types in their defect database which provides the liberty for inspector to choose amongst those (SIB-Bauwerke, 2013). The notion of the digital inspection refers to digitizing the collected data which is done

traditionally by inspection reports and forms. This notion is fairly developed in German BMS by database integration; however, the system is still lacking visualization in a BrIM (Helmerich et al., 2008). InspectTech software of Bentley Systems© is one of the numerous efforts of digital inspection implementation which also integrates a GIS-based bridge management by providing a digital inspection through an application for handheld devices (Bentley Systems, 2014). Hu and Hammad (2005) proposed a location based computing system to facilitate the data collection activities of the bridge inspection by registering defects on the 3D model of the bridge, however, their model is not object-oriented and the standardization issues are not concerned in their research. Kansai (2014) utilizes a total station surveying camera equipped with a built-in crack scale and 3D database management system for remote concrete crack measuring. The system is named KUMONOS and is able to facilitate the crack detection and inspection on concrete structures. Kluth et al. (2008) proposes the use of 3D building model as a centric database for lifecycle management of reinforced concrete bridges in which data about material properties, deteriorations, and inspections are stored with reference to objects. However, this research does not try to visualize the inspection data and does not tackle the interoperability issues. Moreover, Lukas and Borrmann (2012) proposed the integration of 3D-model based management of a bridge and a network-level maintenance optimization. They explored the idea of referencing the condition rating data (e.g., environmental load and inspection data) to the 3D geometric representation of the bridge. Also, on a network-level, optimizing and prioritizing the maintenance measures are proposed based on the calculated condition indices. However, this research does not

suggest a solution for the practical issues of digitizing the inspection data in state-of-practice and the visualization of inspection observations is not proposed.

Inspection Processes

Quality inspection is an experience-based work and bears subjectivity in its notion. Besides, the processes of this job depend on the type of the structure. In spite of all efforts for the standardization of various factors in quality inspection, at the end, the inspector should decide about the rating of a component based on his or her experience which allows the investigation of the cause or origin of the defects.

In practice, bridge inspection tasks take place in two levels. Tasks of the primary level of inspection include highlighting problems for the proper course of action as well as specifying and rating the worst part of each component by taking photos or drawing sketches. This step basically involves visual inspection by a certified bridge inspector. The secondary level of inspection is an in-depth and quantitative inspection which tends to accurately assess the reported problems from primary level of inspection. In the second level, specialized tools, techniques and equipment are used and, as a result, it provides detailed information on the condition of a particular bridge component (BIM Inspection Manual, 2007). The literature review does not aim to repeat the inspection procedures of bridge inspection codebooks or guidelines, so the generic processes of traditional bridge inspection through paper reports which should be compiled by inspectors are briefly noted in the following: (1) review of previous records and information, (2) inspection schedule preparation, (3) informing authorities if any lane closure is required, (4)

recording clear and descriptive inspection notes and comments, (5) achieving a general course of action at the beginning of inspection, (6) close-up visual inspection including activities like scrapping and measuring. It is worth mentioning that the inspector should be familiar with the general structure of the bridge in order to be able to locate the defect susceptible spots, and (7) rating the inspected components based on provided formulas in the corresponding codebook and collected data (Silano, 1993). However, the use of digital inspection can facilitate multiple steps of the aforementioned inspection processes. In digital inspection the collected inspection data are entered to electronic forms through the use of the inspector's handheld device.

The procedure of bridge inspection and assessment in Europe were initially developed for reassessment of railway bridges, named Sustainable Bridges. The International Association for Bridges and Structural Engineering later extended the scope and defined various phases of assessment for all types of bridges (Figure 2-5). The unifying efforts of the standardization for new constructions succeeded to great extent; however, a European standard for reassessment of existing bridges is yet to be established (Helmerich et al., 2008).

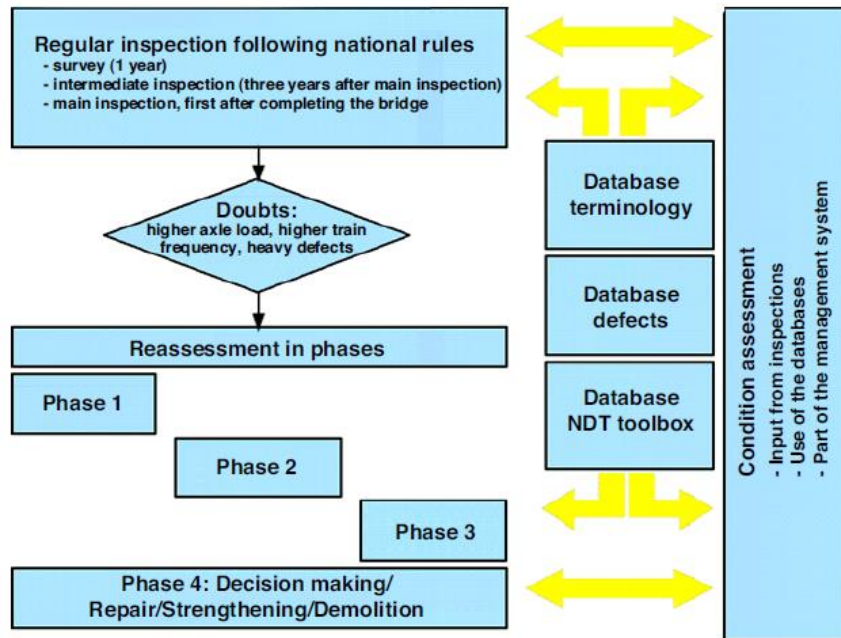

Figure 2-5 Inspection and assessment processes (Helmerich et al., 2008)

2.3.3 COMMON DEFECT TYPES OF CONCRETE BRIDGES

Bridges can be categorized in concrete, steel, timber or a combination of those based on their composing material; however there are various ways of categorizing them (e.g., based on structure, functionality). Each component of the bridge may be prone to specific deterioration based on its material, structure and loading; however this review aims to present a brief introduction to common deterioration consequences and damages of concrete structures in order to narrow down the subject. Common defects of concrete structures are numerated by BIM reference manual (2007) of Alberta as different types of cracks, scaling, spalling, delamination and collision damage. (1) Shrinkage cracking usually appears after the cement pour due to unabsorbed stresses of shrinkage resulting from evaporation and temperature gradients. Usually their orientation is across a slab or at a right angle to the drying wind direction. Shrinkage cracks are not critical generally.

(2) Flexural cracking is caused by over-flexing a zone whether by dead or live loads; beyond its flexural strength as considered by the designer. It usually occurs in the deck zone in which the bending moment direction changes or at the top surface of one-end supported slabs which undertakes tension. Crack width can be measured by a crack comparator. Table 2-2 categorizes the cracks based on their width. (3) Shear or diagonal cracking are caused by over load which should be considered critical and usually appears on the vertical faces near the supports. (4) Scaling is defined as the surface mortar and aggregate removal which usually occurs due to chemical breakdown of the cement by freeze-thaw cycles. (5) Spalling is the loss of surface chunks in result of reinforcement steel corrosion which causes corrosion expansion and cracking. It occurs on concrete surface and the reinforcing steel is often exposed in a spall. (6) Delamination occurs at the separation zone of the concrete and the reinforcing steel due to expansion of the corroding rebar. (7) Collision damage happens because of vehicular collision with a bridge component (BIM reference manual, 2007). Figure 2-6 presents examples of common concrete structural defects.

Table 2-2 Width-based crack categorization in concrete (BIM reference manual, 2007)

width<0.1mm	Hairline
0.1mm≥width>0.3mm	Narrow
0.3mm≥width>1.0mm	Medium
width≥0.1mm	Wide



(a) Shrinkage cracks on a deck



(b) Flexural crack on a tee beam

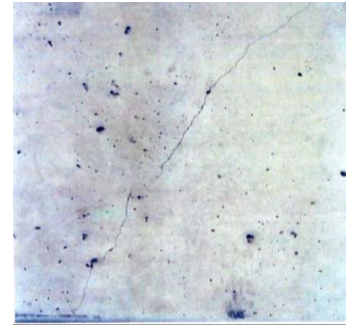

(c) Shear crack on a girder



(d) Scaling on a deck



(e) Spalling on leg of curb girder

Figure 2-6 Common defects of concrete structures (BIM reference manual, 2007; BIRM, 2012)

2.3.4 COMMON PRACTICES OF CONCRETE PARTIAL/NON-DESTRUCTIVE TESTING

Non-destructive evaluation or NDT includes a variety of analysis techniques which enable the evaluation of component geometries and material properties without causing any damage to the soundness of the component (Cartz, 1995). There are various kinds of field testing ranging from a very simple and estimated chain drag test to a very sophisticated and accurate ultrasonic echo test or ranging from superficial visual test to in-depth radar test. Some of the most common methods in practice are note in the following. (1) Visual inspection is defined as the basis for other types of testing and inspection and basically includes visual assessment of concrete slabs for defects

alongside various other tasks which usually is called level one or primary inspection (BIRM, 2012). (2) Coring is a partial destructive test which involves removal of an isolated cylindrical core sample from a concrete slab by the use of a specific electric or pneumatic drill. This sample reveals the properties of the concrete component. (3) Chloride Testing (CHL_2) is a partial destructive test since it requires drilling. The test determines the likelihood of corrosion of the reinforcing steel in concrete by measuring the locked-in chloride in aggregates. (4) Copper Sulfate Electrode (CSE) or half-cell testing is repeatable test which measures the electrical potential between rebar and a reference electrode in order to identify the extent of corrosion in the reinforcing steel mat. A top mat of electrically continuous reinforcing steel in the concrete deck is the main condition of this test (BIM reference manual, 2007). (5) Sonic test enables an in-depth evaluation by measuring the acoustic wave velocity variation due to substance variation in defective areas. A new technology of hand-held and automated sensor array alongside acoustic wave source and the data acquisition station makes it an ideal precise NDT test. (6) Ground-Penetrating Radar (GPR) involves the transition of high frequency pulsed electromagnetic waves for subsurface assessment. Electrical properties of the material determine the velocity of the travelling wave which reveals data about the thickness and in-depth defects. (7) Impact-Echo Testing uses the reflection of impact-generated sound waves by internal defects or external surfaces to reveal concrete slab's properties (Sack et al., 1995; BIRM, 2012). Table 2-3 provides a comparison of the features of different NDT methods.

Table 2-3 Comparison of concrete NDT methods, adapted from (McCann et al., 2001)

Inspection method	Parameter measured	Advantage	Disadvantage	Cost
Visual	Surface condition	Quick; modest skills required	Superficial	Low
Coring	Specific internal dimensions	Definitive dimensions	Partial destructive; Measurement only at test point; scars the bridge	Moderately high
Chloride Testing	Chloride content	Preventive detection of reinforcement corrosion	Partial destructive	Moderate
Copper Sulfate Electrode	Electrical potential	Quick; measures the extent of reinforcement corrosion; allows corrosion extent monitoring	Requires electrically continuous reinforcing steel mat	Low
Sonics	Wave velocity; tomographic cross-sections	Moderately slow; gives useful information on major components	Requires skill to interpret data	Moderately high
Radar	Electromagnetic wave velocity	Quick; can give good penetration; can give good image of internal structure	Poor penetration through clay infill and salt contaminated fill; requires skill to understand data	Moderately high
Impact Testing	Mode shapes and/or signature	Gives some indirect measure of current condition	Difficult to quantify data; heavily damped masonry bridges give yield little response	Moderate

Numerous other types of concrete field testing methods have been used e.g. chain drag, rebound hammer, pull out test, windsor probe, ultrasonic pulse velocity, delamination detection machinery, electromagnetic methods, pulse velocity, flat jack testing, infrared thermography. It is worth mentioning that, new researches alongside new technology advancements in this field are emerging and their facilitated usage is resulting in more accurate assessments. Introduction of automated ultrasonic testing with transducers in array management which allows the dry contact point for scanner instead of gel usage as the coupling agent is a step forward in this field which is shown in Figure 2-7 (Streicher, 2007). Adhikari et al. (2013) proposed image-based retrieval of crack properties in concrete components which uses image processing techniques to extract the properties of

the superficial and visual cracks; however, their method involves only crack as target and it requires a clean component surface for crack detection. Besides, it enables the change detection of cracks. Chen et al. (2013) proposed the leverage of pointcloud data from 3D Light Detection and Ranging (LiDAR) for superficial damage detection which enables visual defect detection with no traffic operations.

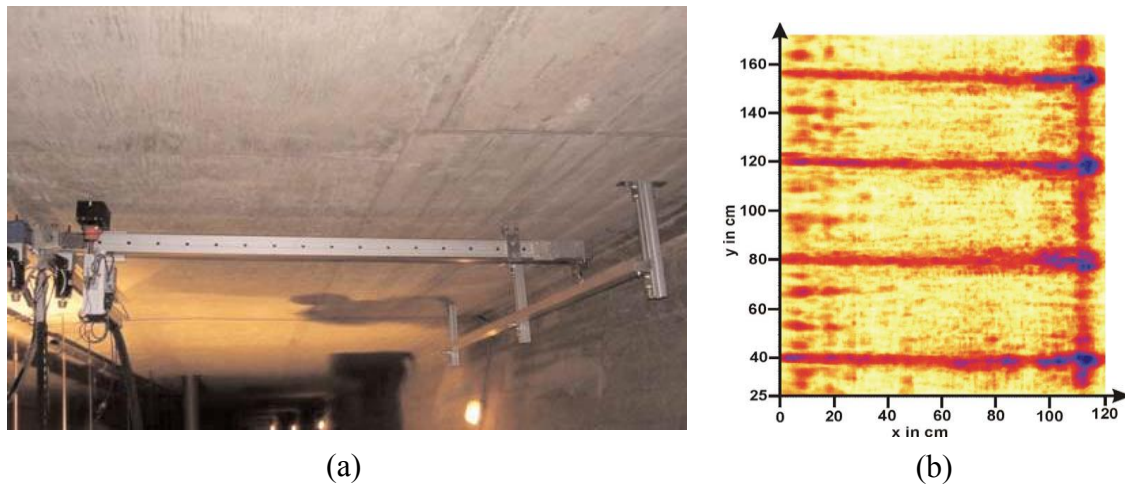

Figure 2-7 (a) Automated scanning of a box girder slab by Ultrasonic Echo testing method, (b) Visualization of tendon ducts in the slab in a depth of 150 mm parallel to the surface (Helmerich et al., 2008)

2.4 BRIDGE AND BUILDING INFORMATION MODELING

The AECOO industry has a fragmented nature and requires multi-domain coordination among different parties involved in a project. This fragmentation causes significant barriers in communication borne to stakeholders due to lack of interoperability in data exchange (Isikdag et al., 2008). Interoperability issues impose a substantial negative effect on efficiency which is equal to 15.8 Billion U.S. dollars per year for U.S. Capital Facilities Industry (Gallaher et al., 2004). Thus, the need for a standard model for data sharing and exchange between involved parties became evident. As a solution, Building

and infrastructure information modeling emerged to facilitate the interoperability in data exchange.

2.4.1 BUILDING INFORMATION MODELING

The Architecture, Engineering, Construction, Owners, and Operators (AECOO) is highly fragmented and complex in nature. Since the AECOO industry gathers multi disciplines and various stakeholders, data sharing as well as the communication among them becomes of a significant importance that affects the efficiency and imposes extra cost to industry. As the US Bureau of Labor Statistics stated; since 1964 all industries had more than 200% increase rate in productivity, whereas the AECOO has experienced a negative productivity rate (AIA, 2012). The need for a standard information model has risen from the obstacles which are faced by traditional interphase communication gaps. The traditional approach in AECOO industry does not allow facilitated information exchange through the different phases of a building lifecycle. Information exchange gaps hamper the accessibility of information for designers from the construction phase and vice versa. In addition, effective O&M requires information of the design and construction phases and likewise for all lifecycle phases of the building. Given that, software interoperability issues impose a substantial negative effect on efficiency which is equal to 15.8 Billion US dollars per year for U.S. Capital Facilities Industry (Gallaher et al., 2004).

As a solution, BIM was proposed to tackle the lack of interoperability in AECOO industry and to allow for information sharing and integration through the whole lifecycle of a building and to provide effective management (Isikdag et al., 2008). BIM is defined

as a parametric digital representation of physical and functional characteristics of a facility that is object-oriented and data-rich. BIM enables various stakeholders to extract queried data about a facility and provides decision support information through the lifecycle of the facility (Associated General Contractors Guide, 2006).

Sjogren and Kvarsvik (2007) research compares traditional document centric approach with emerging BIM. The traditional approach results in difficulties in data sharing, errors in communication among various domains involved in the project and information losses within the same domain. Furthermore, due to interoperability obstacles, redundant data entry reaches to seven times before a construction project completion. Apart from the mentioned shortcomings, the integration of O&M and a lifecycle management of the facility has not been considered before. On the other hand, the application information centric approach makes it possible to have an effective communication between various domains involved in a facility construction project as well as data exchange among the different phases of a facilities' lifecycle through a unique repository of object-oriented data.

Vanlande et al. (2008) distinguishes between two methods of dealing with data in BIM; namely, data exchange and data sharing. In data exchange, there is a master copy of data while the queries of that data can be exported to other software programs. The ownership of data is assumed for the data importer software. Thus, the ownership would be transferred through each data exchange step. However, in the data sharing method, there is a master pool of data with a unique ownership that brings advantages in the control of

data revision processes of the database. In either ways the BIM can be stored as digital file or in a database.

Methods of exchanging and sharing of BIM are categorized into five methods by Isikdag et al. (2007): (1) Data exchange using physical files transferred through physical storage drives, e.g., CD, hard drives and web networks e.g., the Internet; (2) Data sharing through Application Programming Interfaces (APIs) which provide accessibility to BIM based on its type, e.g., Extensible Markup Language (XML) files; (3) Data sharing using a central database which is accessible through multiple applications; (4) Data sharing by developing parallel synched databases; and (5) Data sharing by providing accessibility to a web-based database through various web service interfaces. The web-based database can be either central or parallel in the architecture. This classification facilitates a tradeoff between the advantages and shortcomings of each method to choose the most proper among them.

2.4.2 BRIDGE INFORMATION MODELING

Traditional bridge design and construction have been highly relying on paper-drawings as primary construction documents and inspection report as the way of data exchange among various domains involved in a project. In spite of the fact that the 3D design of bridges is becoming popular, the bridge industry does not leverage a core digital 3D product model in state-of-practice. Lack of a centric information model in this industry causes obstacles for a streamline and on-time product delivery, increased cost and time of data exchange and low quality induced by error-prone data exchange methods (Chen et

al., 2006). Other close industries leverage the 3D data model across the lifecycle of their product and have experienced added efficiency thereby (Khanzode and Fischer, 2000).

Chen et al. (2006) defines the scope of Bridge Information Modelling (BrIM) into two distinct areas: (1) Providing a centralized 3D data model of a bridge which acts as repository of the bridge design phase; (2) A standard data model for bridges which enables facilitated inter-domain communication and inter-phase data exchange. A standard data model and a standard data format does not yet exist in the bridge industry (Chen et al., 2006). In spite of the fact that these two proposed promised scopes are not yet available, there are various extra anticipated advantages which are inspired from other close industries and bridge domain researches that can be expected from a standardized data model in order to evolve the 3D model of a bridge from a design platform into an all-round information management tool whose applicability spans across the entire project lifecycle. Leveraging an object-oriented standard data model which tackles interoperability and extensibility issues of the highly fragmented bridge industry promises a substantial improvement of quality and reduction of cost and time (Hammad et al., 2013).

BrIM is envisioned as a central 3D data model which is also a query-able repository for multi-domain data. Figure 2-8 illustrates the components and associations as well as integration of design and construction processes of a precast concrete centralized data model (Sacks, 2002). Using of a central data model across multiple involved disciplines in a project enables the extraction of updated information and drawings related to a given stakeholder; thus eliminating the labour-intensive work of multiple 2D drawings and

redundant textual data among different stakeholders and reducing the error caused by data re-entering. Table 2-4 compares 3D design versus traditional 2D design to demonstrate the evident need of applying 3D design in bridge design practice. Furthermore, the obvious need of inter-phase communication in the lifecycle of a bridge makes it necessary to be considered as a major characteristic of BrIM. Since no substantial effort has been done in this aspect in the bridge industry, the perspective of the development process, promised benefits and probable shortcomings can be interpreted from the development of similar concepts in close industries like BIM in the building industry. Accordingly, integrated design and construction processes which are the result of an integrated 3D data model tackle interoperability problems throughout different phases of a bridge lifecycle (Chen and Shirole, 2006).

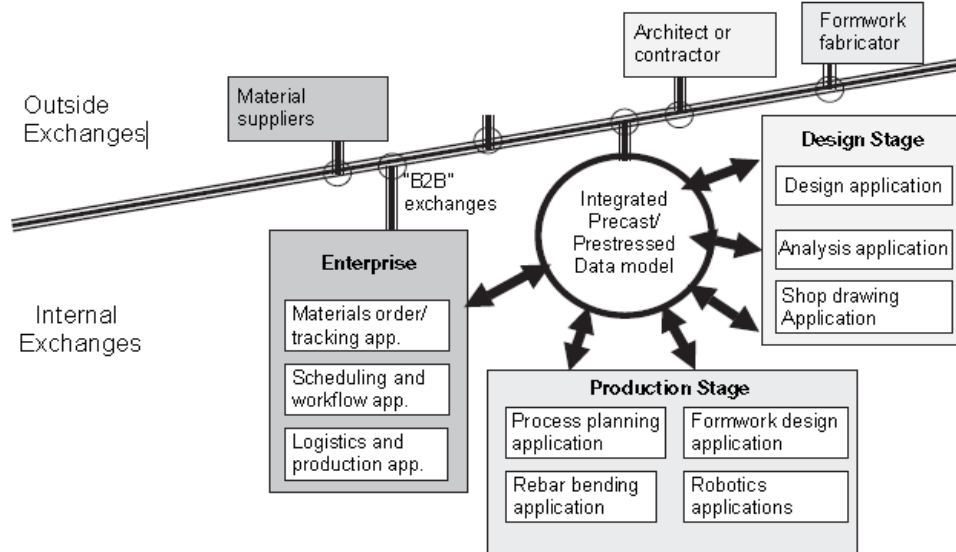

Figure 2-8 Centralized data model supporting integrated process (Sacks, 2002)

Table 2-4 3D documentation processes versus 2D drawings (Chen et al., 2006)

2D	3D
2D CAD provides an Electronic “drawing board”	3D enables a parametric model
2D drawings contain the information	3D model contains the information; 2D drawings are only reports
2D drawings intended to be human-readable; separate manual data entry is required for analysis	3D model is computer readable , such that direct analysis are possible
Coordination is difficult; information is scattered among different drawings and specifications clauses	Coordination is automatic: 3D model is the single source for all product information
Manual checking	Automated checking
No support for production	Potentially full support for production (via CNC codes etc.)

2.4.3 IFC MODEL

The Industry Foundation Classes (IFC) standard is an object-oriented, non-proprietary BIM data model which is founded by BuildingSMART Alliance (BSA), formerly named International Alliance for Interoperability (IAI), in order to tackle interoperability problems in an effective way by providing a universal basis for process improvement and information sharing in the building industry (East, 2007). Being non-proprietary enables this data model to gather various stakeholders in a building project to leverage this model across the industry and subsequently is now well-known and supported by a large number of CAD (Computer-Aided Design) enterprises and CAD software program developers (IFC, 2013; Khemlani, 2004). IFC defines the model by entities as part of the data architecture. These entities represent tangible building components (e.g., columns, walls,

windows) as well as various concepts (e.g., spaces, costs, schedules). Moreover, an entity can be associated with different properties (e.g., text, geometries, relationships) (Liebich, 2009). It is worth mentioning that a more extensive effort in terms of scope has been initiated by the International Standards Organization (ISO) in 1984 and named as STEP (STandard for the Exchange of Product model data). STEP addresses product design in all the industries which deal with 3D products and tackles interoperability of product model visualization and exchange. The building industry community involved in STEP realized the need of a domain-specific standard data model for buildings. Consequently, the effort for IFC development was initiated by IAI (Khemlani, 2004).

BSA developers chose a hierarchical and modular architecture for IFC. The modular architecture of each layer in IFC facilitates the extensibility of the model by providing proper distinction among entities which allows reusing the defined entities. As shown in Figure 2-9 shows the hierarchical architecture of IFC data schema comprising four conceptual layers namely domain layer, interoperability layer, core layer and resource layer. Based on the modular architecture of IFC, each layer includes various modules, i.e. entities, types, enumerations, property sets and quantity sets (IFC, 2013).

Regarding the IFC's scope, being easy-to-extend is an evident expectation of IFC as a standard data model. IFC as an object-oriented model associates the required entities and their corresponding predefined attributes to the model of an object. The fact that predefined attributes can be inherited by other entities reduces the redundant redefinition of interchangeable attributes and facilitates the extensibility thereby (Ma et al., 2011).

The IFC specifications are written in EXPRESS language which allows the IFC to be a neutral data format to describe, exchange and share information. EXPRESS language syntax is an XML-based expression and script which is compact and well suited to include data validation rules within the data specification. Besides, an ifcXML specification is provided as an XML schema 1.0 (BuildingSMART, 2012). XML-based languages use a text syntax to structure, store, and transport data. XML documents partially dictate the behavior of software which processes them and from the architecture point of view it conforms to the Standard Generalized Markup Language (SGML). Besides, the neutral data format enables a software- and hardware-independent data storage and exchange between client and server regardless of the language used at each end, which effectively tackles the interoperability issues (Barry et al., 1997).

Weise et al. (2008) mention three approaches for IFC standard extension with their corresponding consequences: (1) Defining new entities and types, which is the best recommended approach. However, its application by BSA takes at least two years; alternatively, (2) Defining proxy components; and (3) Reusing types and property sets; which requires additional implementation agreements about the definition of the property sets and proxy components.

In this research the proposed approach for integration of inspection results with BIM is explained in Section 3.6 which defines new entities, types and property sets.

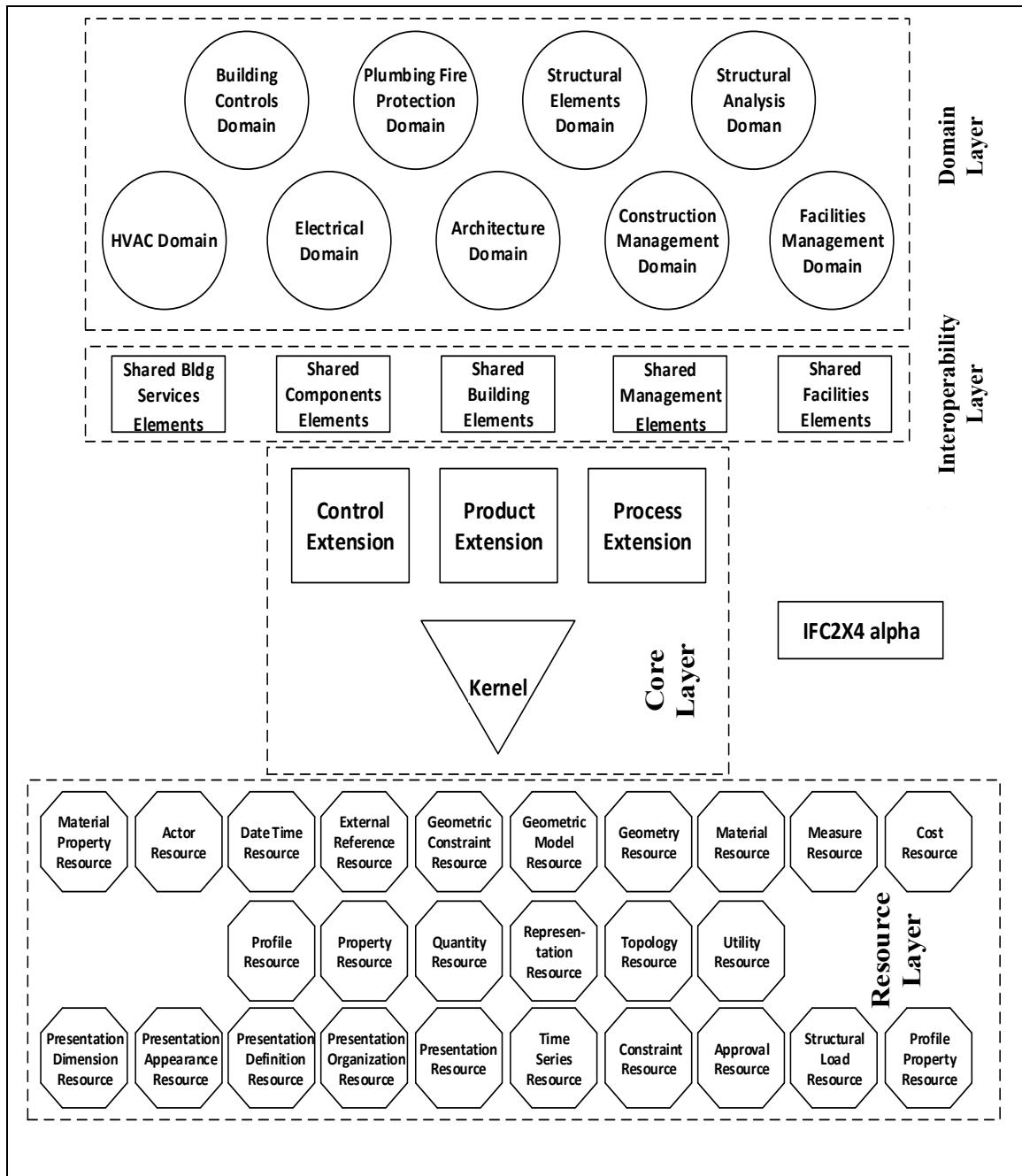

Figure 2-9 The overall architecture of the IFC model (IFC, 2013)

2.4.4 IFC-BRIDGE

Tow concurrent efforts were on going in 2002 to develop a product model for bridges on the basis of IFC; with the same goals and methods of the IFC for buildings, one in France and the other one in Japan. They had a similar approach in their work in spite of not being aware of each other's research. Eventually, a new IFC-Bridge product model resulted from the merging process of their researches with the support of IAI aiming to create an internationally accepted standard (Yabuki, 2006).

Although IFC-Bridge is yet to be released by BSA, multiple reports and publications reveals their area of focus in the development process. The scope of IFC-Bridge defines the major structure of the bridge, geometry of components, material associations and technological terms. As can be seen in Figure 2-10, the bridge spatial structure components definitions are added by the use of some entities inherited from IFC4 and various newly defined entities (Van Nederveen et al., 2013); bSDD (building SMART Data Dictionary) is an electronic database of unique concepts which ensures that the meaning is communicated instead of merely delivering the terms. bSDD is developed upon the bases of International Framework for Dictionaries (IFD) which is a standard for terminology libraries. It is considered as one of the core components of the buildingSMART technology which provides flexibility by linking information models to various databases (Palos et al., 2013).

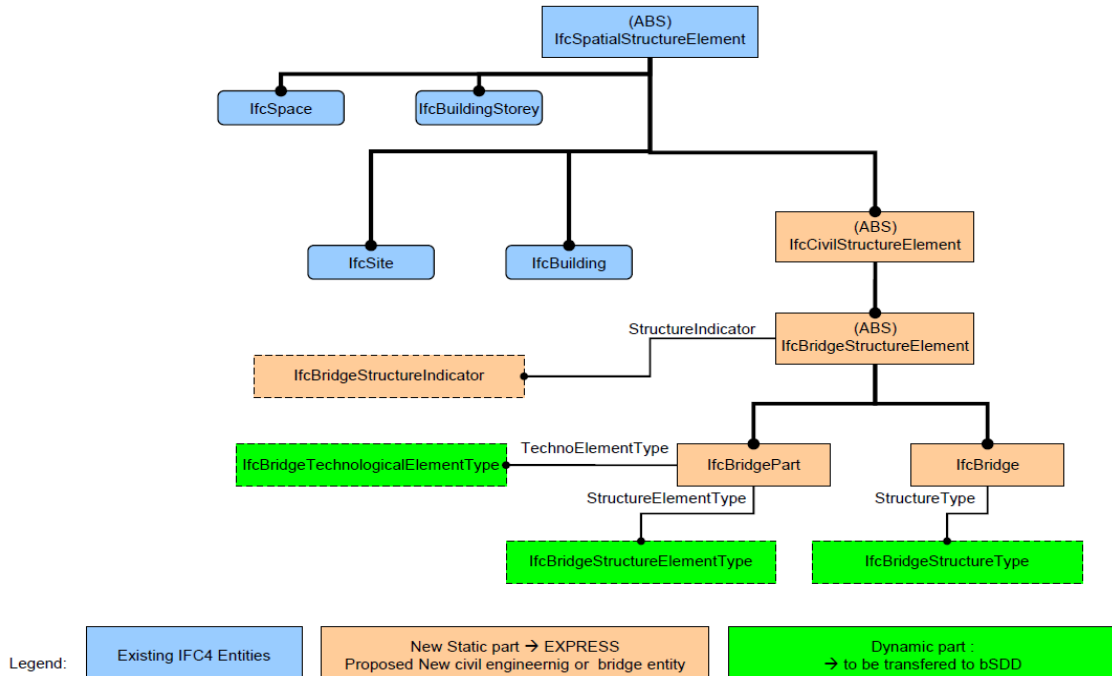

Figure 2-10 Bridge spatial structure components (IFC for Roads, 2013)

2.5 4D VISUALIZATION OF INSPECTION DATA

Effective asset management requires a well informed decision making. Visualization of large asset inventories and large amount of non-visual data results in easy-to-grasp data and more accurate asset management (Kyle et al., 2002). Visualization methods can be categorized based on the data demonstration method into color coding, symbolizing and 3D components or a mixture of these methods. Hammad and Motamedi (2007) visualized asset conditions by using color coding on 3D components in operation phase of the assets which is shown in Figure 2-11. Hu and Hammad (2005) developed a location-based computing approach which supports data collection and visualization of inspections. The method uses symbols and different colors to visualize the data; however, their research is not BrIM based and does not consider standardization issues.

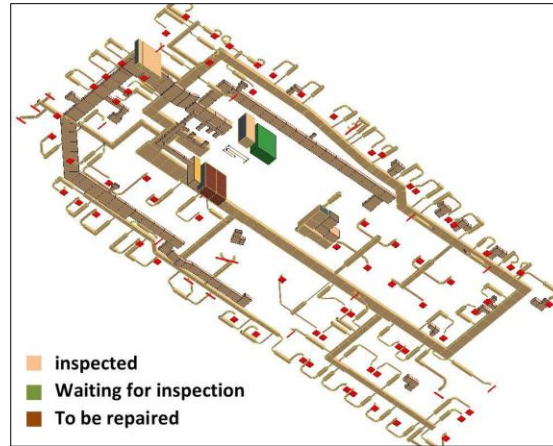

Figure 2-11 Color coding visualization of HVAC model during the maintenance phase (Hammad and Motamedi, 2007)

In 4D visualization, the 3D model is linked with the timing information of the activity schedule (Koo and Fischer, 2000). The major research efforts in 4D context are pertinent to 4D visualization of construction activities and asset management. Kang et al. (2007) demonstrates the role of enhancing collaborative work by 4D visualization in site planning. The study of several construction projects which have been using 4D visualization of construction work sequences demonstrated that the 4D visualization enhanced the understanding of the project crew and stakeholders about the construction sequence and potential upcoming problems.

Effective progress management allows the stakeholders and managers of a project to foresee the potential shortcomings. Moreover it enables the management to prepare and preform corrective actions by monitoring project progress (Fleming and Kopplemna, 1996). However, Yoon et al. (2006) raises some doubts about the reliability of current progress monitoring methods in case of a disaster or ad-hoc decisions based on the experience of project managers. Akcamete et al. (2010) research links maintenance work

orders to the BIM model to investigate the problematic trends by a spatiotemporal analysis. The work order data were linked manually to the model due to lack of interoperability, and visualization was performed through symbols and different colors. However, they have not considered the defect propagation trends.

2.6 SUMMARY

In this chapter several researches, technologies and standards related to bridge management were reviewed and bridge O&M with a focus on bridge inspection were explored. Moreover, information modeling in the building and bridge sectors were reviewed and the standardization efforts were assessed.

The literature review revealed the limitations of BrIM in comparison with the achievements of BIM concerning the lack of interoperability and extensibility in spite of the current efforts to resolve these issues. This chapter enlightened the role of standardization in lifecycle management of bridges and subsequently the role of the lifecycle management of bridges as an effective and efficient infrastructure management. These findings assist us to proceed in the direction of our proposed approach which enables a step forward in bridge lifecycle management by integrating inspection observations into the BrIM.

CHAPTER 3 PROPOSED APPROACH

3.1 INTRODUCTION

After an infrastructure is commissioned, its lifecycle will be comprised of five main phases, namely, planning, design, construction, O&M and demolition. Various disciplines and stakeholders are involved in the projects of each phase, form various parallel layers, each of which dealing with its own pertinent information and also having a partial information exchange with other layers. Due to the fragmented nature of the AECCO industry, the lack of coordination among various phases and layers impose significant economic losses caused by redundant data management processes.

The traditional approach deals with each phase independently and leaves a gap among these phases. Besides, in practice, O&M data are often collected on paper as reports. Even after being digitized and processed as information, the available information is fragmented to different stakeholders who collect different types of O&M data. Thus, a cross-phase, cross-layer information exchange becomes inevitable which can be achieved through an object-oriented information model. In the absence of a framework that allows object-oriented information collection, the processing of the collected data imposes significant amount of labor and time. Moreover, the cost of retrieving the required information increases.

Substantial configuration state changes of the bridge or any decision about the bridge layout happens at the design, construction, deterioration, maintenance, rehabilitation and reconstruction of the bridge. Providing an updated BrIM through the bridge lifecycle

involves visualization of structural changes. The design, as-built modifications, structural defects, maintenance patches and newly added components of the bridge after rehabilitation identify the bridge configuration which has to be reflected in the updated 3D model of the bridge. The updating process of design information with as-built changes during the construction and then using this model during O&M is costly; however the outcome will be a model which shares a multi-phase source of information and results in an optimum information management. The lack of an easy-to-access object/phase-oriented information sharing method has resulted in multiple frameworks in BIM. However, very minor work has been done in the bridge management domain.

This research proposes a framework to extend the usability of BrIM into the O&M phase and tries to resolve the related issues including feasibility, interoperability and extensibility. Thus, As mentioned in Section 1.2, the proposed methodology covers two main objectives which are: (1) the improvement of bridge O&M processes with a focus on bridge inspection by improving the process of documentation, data storage and information visualization, (2) An IFC extension model which aims to define various inspection data in the IFC model and interrelate them to BrIM. This research proposes adding inspection observations to the model of the bridge. The proposed method not only considers the integration of defects with the 3D model of the bridge but also the interaction of the inspector with the 3D model at the inspection site. Enabling the inspector to interact with the 3D model of the bridge results in a more accurate inspection report and also it will be significantly applicable for maintenance planning and management. Moreover, benefiting from the linkage of the time dimension and the

object-oriented BrIM, the 4D visualization of defect propagation apart from other visualization benefits mentioned in Section 2.5.

The integration of inspection observations and BrIM alongside the proposed standardization, evolves the 3D model from a merely design platform to a lifecycle information management tool at both the project and the network-levels.

3.2 PROPOSED FRAMEWORK FOR BRIM-LIFECYCLE DATA INTEGRATION

Substantial configuration state changes of a bridge or any decision about the bridge layout happens at the design, construction, deterioration, maintenance, rehabilitation and reconstruction of the bridge.

In this research a new framework is proposed for the advancement of information modeling and management discussed in Sections 2.4 and 2.2 respectively. The proposed framework consists of five main modules including enabling technologies, dynamic data and applications which are centered around a BrIM. BrIM alongside the standardize data exchange methods form a platform for integration and visualization. Figure 3-1 represents the layout of the proposed system; each module is explained in the following.

(1) BrIM: BrIM, as explained in Section 2.4.2, enables the integration of various types of data e.g. cost data and O&M data, with the 3D model of the bridge in an object-oriented design paradigm. Moreover, it enables a cross-domain and cross-phase data sharing through the lifecycle of the bridge.

(2) Enabling technologies: based on the definition of the proposed framework, enabling technologies module includes tools and techniques that enable the collection, capture, extraction, analysis and dissemination of data. Data capture technologies vary based on the type of data, e.g. subsurface NDTs (Section 2.3.4), Close-circuit Television (CCTV), Ultra-Wideband (UWB), Radio Frequency Identification (RFID), LIDAR and the Global Positioning System (GPS). Usually the collected data are not directly usable without proper analysis and processing. The analysis and processing methods depend on the type of the collected data and employed technologies, as well as the required output, e.g. image processing and Artificial Intelligence (AI). As the last classification of this module, mobile computing and visualization technologies enable remote data access, representation and collection. This research proposes the inspector interaction with the BrIM platform through the leverage of handheld devices, which enables information collection instead of data collection that requires further costly and prone to error data management processes. Augmented reality as well as 4D visualization (Section 2.5) which enables the visualization and analysis concurrently are also considered in this module. This research links the temporal data of the defects and maintenance works to the BrIM in order to enable the 4D visualization of inspection data and maintenance progress monitoring.

(3) Dynamic data: dynamic data module hosts a wide range of data since the lifecycle management of a bridge requires the collection and processing of various data types ranging from generic data which affect the whole structure, e.g., Annual Average Daily Traffic (AADT), to very object-specific data about the condition of components in the

bridge. Dynamic data are categorized into real-time data and report data according to the sources of data and the frequency in which the data are available or required. Some factors have instantaneous impacts on the operation of the structure and should be constantly monitored, e.g. AADT, weather data, accident data and structural health data. However, some data cannot or need not be collected at a high frequency, or perhaps require human intervention and post-processing before they can be applied. These types of data are categorized under the report data, like inspection results which require human intervention or progress monitoring data which require longer interval data collection frequency for trend assessment.

(4) BMS: BMS integrates a wide spectrum of network-level data. As the main contribution, the proposed framework provides a large amount of data in a structured manner over a wide range of domains. Thereby, this framework facilitates the communication and data sharing of cross-domain applications by the proposed structure. The wide range of applications can be classified into four groups, namely decision support, spatio-temporal analysis, visualization and automation. (a) Decision support applications enable managers in making informed decisions by providing relevant information at the required time, e.g., quality assurance and resource allocation. (b) Spatio-temporal analysis enables the concurrent analysis of various activities in relation to time and space attributes in order to identify potential spatial and temporal conflicts, e.g. cost estimation. (c) Visualization applications are intended to enhance the visual representation of the model, by linking various dimensions, i.e., 4D visualization which links the 3D model and time and 5D visualization which links 4D to cost data. Moreover,

one of the advantages of the proposed framework is the ability to add any new dimensions to the model representation, e.g. inspection and maintenance data. The proposed data model allows us to superimpose the time-stamped maintenance and inspection records to the 3D model. (d) Automation applications: in the case of a disaster, the leverage of an automatic system can save time and improve the accuracy of operations. Disaster management requires significant level of collaboration in an agile and accurate attitude which can be improved by the proposed method through the integration of its modules with GIS-based management system.

(5) GIS-based BMS: GIS-based BMS integrates data from the BrIM and dynamic data using the GIS-based platform through the use of standardized data exchange formats (e.g. XML or IFC). The necessity of visualized GIS-based format is manifested in the network-level applications. This integration requires geo-referencing of all components in the system. It is worth mentioning that GIS is not a mere visualization tool, but it allows performing various kinds of analysis and data processing. In case of a disaster, using a GIS-based BMS can help in preventing the collapse of the network system, where a large amount of data needs to be considered in order to make the optimum decisions. Regarding to interoperability issues in the network-level management, the example of CityGML represents a high-level of standardization. CityGML is a new standard derived from XML which was developed to facilitate the exchange of 3D urban objects such as buildings, land use and transportation components (Kolbe, 2012). However, CityGML does not have all the details of different types of infrastructures such as bridges.

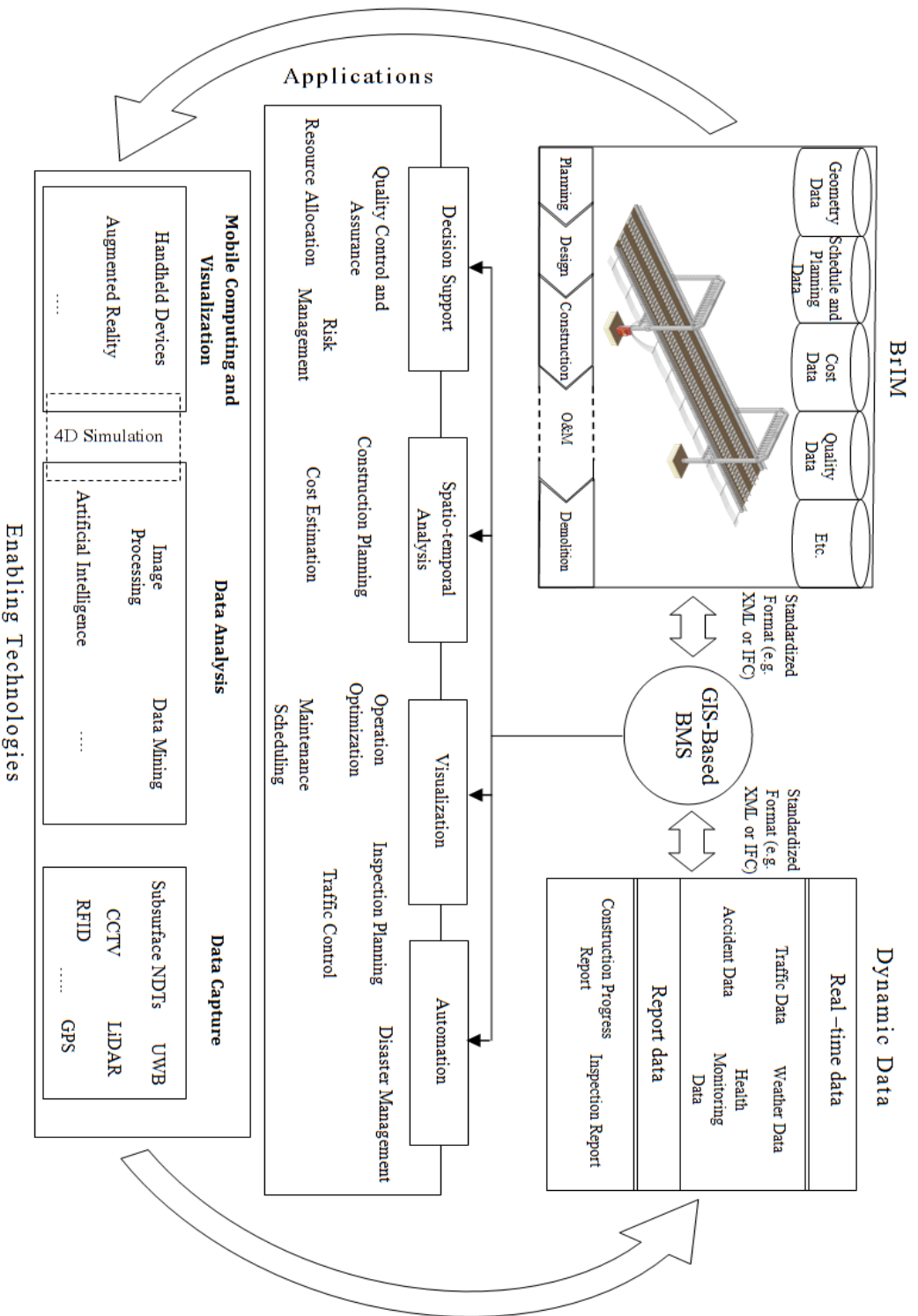

Figure 3-1 Framework for BrIM-lifecycle data integration (adapted from Hammad et al., 2013)

3.3 BRIM-INSPECTION DATA INTEGRATION APPROACH

The proposed approach aims to add the 3D models of structural defects from inspection observations (e.g., cracks) as information objects to the BrIM through an easy-to-use interface equipped with a set of predefined models of defect patterns which have adjustable properties. Based on this method BrIM would become a lifecycle management solution. The lifecycle BrIM reduces data process redundancy for inventory data and provides anytime access to lifecycle management information as illustrated in Figure 3-2. In the absence of a system that allows object-oriented information collection, the data processing of the collected data imposes significant amount of labor and time. Moreover, the cost of retrieving queried information increase. Also the method provides immediate access to updated O&M information which would be manifested in case of a disaster and emergency management.

The proposed method deals with two distinct goals and their pertinent implementation issues: (1) Visualization of the O&M observations on the BrIM, which aims to add visualization and navigation benefits at the project level, and (2) Integration with the visualized O&M observations which leads to various project and network-level benefits (as explained in Section 3.2, e.g., redundancy elimination, updated BrIM). Various issues should be considered for the achievement of these goals including feasibility, interoperability and extensibility which are discussed in the following. Conventional modeling skills impose extra costs to the project due to the required professional training programs for the O&M operators; the feasibility of method thereby depends on the facilitation of the defect integration process. Updating process of design information with

as-built changes during the construction and then using this model during O&M is costly; however, this research suggests updating of BrIM by O&M operators (i.e., inspectors and maintenance operators) interactively at the project site through a facilitated method using available design and information modeling tools in order to reduce the cost and maximize the feasibility. Based on the method for visualization of inspection data, the defect model should be as close as possible to its real shape, which increases the complexity of defect modeling considering the irregular shapes of defects. Therefore, the application of the proposed method has to be facilitated through a user-friendly interface to avoid extra cost. Furthermore, a tradeoff between the modeling complexity and visualization details of the defect models has been considered in the proposed method in order to achieve an optimum level of defect visualization and easiness of use. In order to tackle the feasibility issue, various types of adjustable predefined defect models are presented.

Figure 3-3 (a) and (b) represent an example of a predefined spalling defect and the placement of this defect on a precast box girder, respectively.

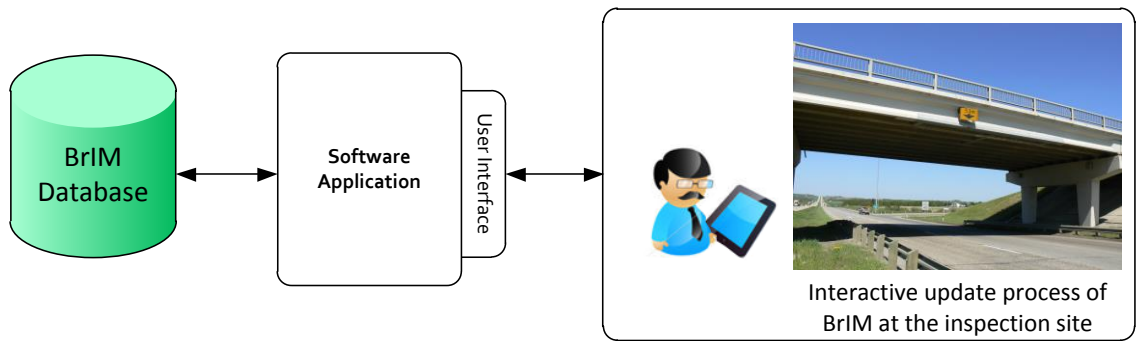

Figure 3-2 Conceptual interaction system

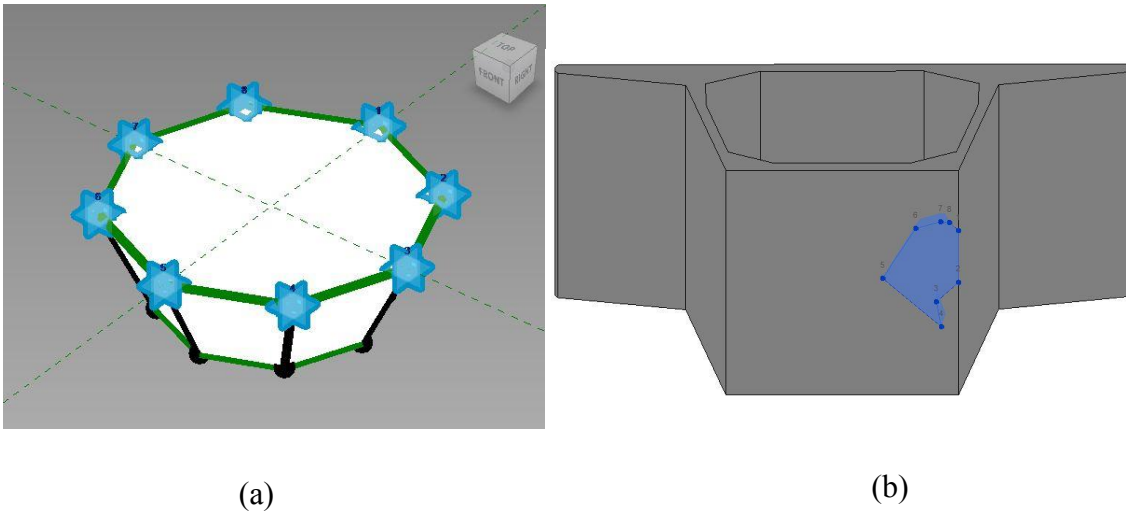

Figure 3-3 Example of predefined spalling defect model (a) and its application on a precast box girder (b)

Additionally, the proposed method tackles the interoperability and extensibility by the following: (1) Using IFC as a communication language among large number of stakeholders involved in the lifecycle management of a bridge and, (2) Extending IFC in order to provide data structure which is required to host lifecycle management information. Besides, there are many defect-related properties which are not defined in BIM. Identifying these properties and defining them in BrIM are necessary for the extensibility of the model. Based on the proposed method, the extension of IFC would provide the necessary base for representing and sharing the collected inspection data in BrIM as an interoperable information exchange format.

The two following Sections (3.4 and 3.4) break down the method to smaller and clear tiers which are, namely, defect modeling and inspection data interaction.

3.4 DEFECT MODELING

Numerous efforts have been proposed to represent the non-visual inspection data in the form of easy-to-grasp data. These efforts can be classified in seven levels: (1) Current practice of conventional paper reports and sketches, (2) Linking the design 3D model of the bridge to the pertinent data of the bridge for documentation purposes, (3) Linking available digital documents (e.g., images and digital forms and texts) to the 3D model of the bridge, (4) Adding the 3D symbols as defect representations to the 3D model of the bridge, (5) Using BrIM as the database of the whole lifecycle information which is being interactively updated through the lifecycle, (6) Updating the BrIM model with O&M data for 4D visualization applications, (7) Using automated, remote and/or subsurface data capturing methods to update the BrIM model. Various levels of the aforementioned efforts are explained in the following. InspectTech software of Bentley Systems© is one of the numerous efforts of digital inspection implementation which also integrates a GIS-based bridge management by providing a digital inspection through an application for handheld devices (Bentley Systems, 2014). Hu and Hammad (2005) proposed a location-based computing system to facilitate the data collection activities of the bridge inspection by registering defects on the 3D model of the bridge. However, their model is not object-oriented. Besides, the standardization issues are not discussed in their research.

This research integrates the inspection observation data and the defect models with BrIM which is considered as the sixth level of detail in visualization, based on the aforementioned levels. The method proposes modeling the common concrete bridge structure defects are discussed in Section 2.3.3. The irregular shape of the majority of

defects requires the development of a method for facilitating the defect modeling. In order to define the crack model as an instance, a prismatic component is used and the pertinent attributes are integrated with it. Figure β-4 shows an example of this predefined crack model that has adjustable geometrical properties in addition to technical inspection data. The combination of multiple crack models enables the modeling of more complex cracks as an approximation of the real defect shape. As another example, Figure β-3 (a) represents a parametric spalling model as a polyhedral shape with adjustable base face vertexes that allow the manipulation of the base side of the model in order to approximate the real defect shape. Figure β-3 (b) shows the interface for adjusting the properties of the crack model.

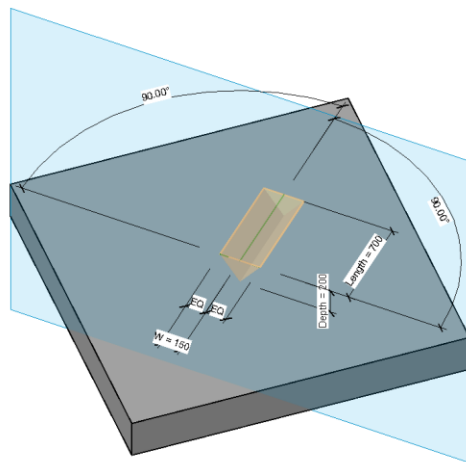

(a)

Name: flexure		
Parameter	Value	Formula
Constraints		
Text		
Image	C:\Users\umroot\Desktop\Defect types-(Manual)\I	=
Dimensions		
Width	12.0	= 2 * w
Volume	8058.00	= (Width
Length	79.0	=
Depth	17.0	=
Angle	45.000°	=
Model Properties		
General		
Required NDT Method		=
Next Inspection Date	10.12.2013	=
Last Inspection Date	10.01.2013	=
Inspector Name		=
Further NDT required	<input checked="" type="checkbox"/>	=
Date of Inspection	10.5.2012	=
Identity Data		

(b)

Figure β-4 Example of a typical crack model (a) and the pertinent properties (b)

3.5 INSPECTION DATA INTERACTION MODEL

As described in Section 3.3, the proposed method provides an interactive update process of bridge information model at the inspection site. Hence, the updated 3D model of the bridge with as-built changes acts as an object-oriented database which contains historical information of the structure.

In order to demonstrate the proposed method of interaction with the information model, a typical work pattern is illustrated. The activities in this work pattern are as follows:

(1) **Pre-inspection preparation stage:** The information model of the bridge is loaded on the inspector's handheld device.

(2) **Inventory data assessment stage:** Inventory data as an essential part of the inspection reports are available in the BrIM. These data are assessed for evaluation by the inspector.

(3) **Locating the inspection targets:** Based on the inspection plan, the specified components of the bridge are identified on the 3D model of the bridge which helps the inspector to locate the components.

(4) **Investigation of a defect:** The inspector applies the inspection guidelines based on the corresponding regional inspection codebook. The defect properties should be measured and compared with the specifications (e.g., in case of a crack detection; the width of crack defines its severity).

(5) Loading the predefined model of the detected defect in the inspection software:

The corresponding defect model is loaded in the software by the inspector.

(6) Adjusting the pre-designed defect model:

In this step the inspector adjusts the pre-designed defect model in order to match its properties with those of the detected defect.

The types of these properties depend on the type of the defect (e.g., in case of crack detection, these properties include width, length, depth, orientation, etc.).

(7) Placing the defect model on 3D model of bridge:

The inspector places the matching defect model on the proper location and orientation based on the real location and orientation of the defect.

(8) Entering required properties of defect:

The required data which are defined by the inspection codebook have to be entered as the properties of defect model in the repository of BrIM.

(10) Saving the model:

The updated model with inspection observation should be saved including the preformed inspection information.

The above activity timeline shows a sample set of processes related to interaction of the inspector with the 3D model of a bridge where a new inspection is taking place and a new defect is detected. Several other scenarios can happen on the same inspection situation (e.g. inspection of a recorded defect, recording multiple defects of the same type).

Figure β -5 represents a comparison between the inspection and documentation processes of the proposed frame work and the current practice of the inspection and documentation

processes. As shown in Figure 3-5(a), The BMS database enables case-specific inspection report generation based on the properties of the bridge and the properties of the inspected component. The inspection forms should be filled by the inspector at the inspection site and transformed to the data management department for digitizing and management of the data. Later, these new data will be added to the Bridge Inspection and Maintenance System database (BIM Inspection Manual, 2008).

However, as shown in Figure 3-5(b), which illustrates the proposed method, the redundant documentation activities are eliminated. Also, the processes in each update cycle is reduced, which leads to a faster model update. The benefits of the proposed method are explained in the following.

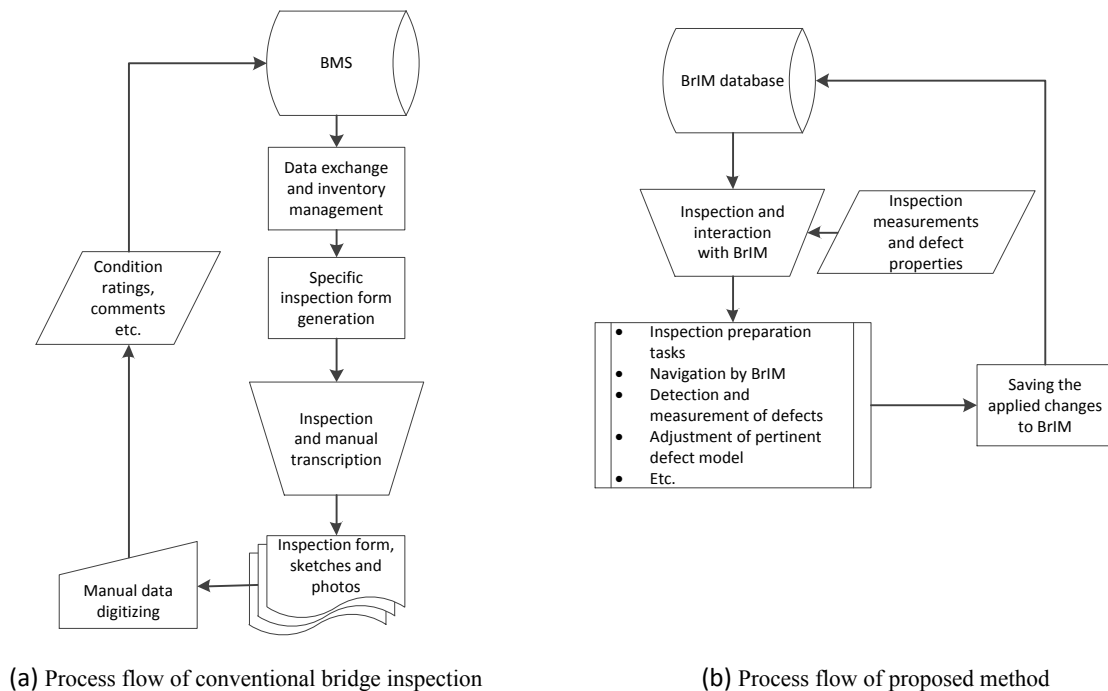

Figure 3-5 Comparison of the conventional method versus proposed method of data integration

Value adding benefits of the proposed method

The full implementation of the proposed approach will lead to a lifecycle management solution at the project-level and network-level as explained below.

(1) Navigational assistance

The integration of the inspection results with a 3D model of the bridge results in the visualization of defects on the corresponding components for the inspector who is equipped with a handheld device. The 3D model facilitates the navigation to location of the component and will result in a more accurate inspection in comparison with the traditional navigation specifications which are based on codebook specifications mentioned in Section 2.3.2 (Hu and Hammad, 2005).

(2) Component history availability

Given that the inspection process depends on human interpretation, providing the inspector with as-built changes and inspection history results in more knowledge-based decisions and interpretations.

(3) Safety

By implementing this method, O&M planners are able to benefit from an information model which is updated at the inspection time, which allows faster maintenance operations and increases the safety for consumers of infrastructure services. Also, severely defective components which have the highest priority for O&M would be easily

found by the O&M team which results in reducing the operation delays due to the lack of information exchange.

In addition, inspection procedures regarding each inspection situation can be added to the inspection information of BrIM so that the inspector would be notified by the safety hints.

(4) Maintenance management

Having the defects of components added to the information model of a bridge enables the inspector to effectively track the propagation of defects over time and allows the maintenance managers to have a more accurate planning and scheduling based on more accessible information of the bridge. Defect integration with BrIM is based on time which allows the implementation of 4D modeling that helps the inspector to visually follow the propagation of defects and to have more accurate interpretations and maintenance suggestions.

(5) Efficient lifecycle management

Knowing that efficient information management in every aspect of lifecycle management results in cost and time reduction (Chen et al., 2006), the proposed approach allows facilitated information sharing by tackling the interoperability issue. Therefore, the labor work for data processing decreases as well as the required time for that process. The proposed method also minimizes the risk of data loss and eliminates manual paper-based inspection record tracking.

Moreover, having O&M information in BrIM allows application 4D modeling for maintenance processes by linking the 3D model to maintenance schedule resulting in an increased efficiency (Alkinci et al., 2003). Thus, a whole lifecycle 4D visualization application facilitates a multiphase resource management of the infrastructure lifecycle. Also, a BrIM integrated with O&M information allows the stakeholders to benefit from query-able object-oriented database, which creates a clear perspective of the infrastructure condition and leads to an effective performance of budget allocation for O&M of the infrastructure (Hammad et al., 2013).

Network-level management can substantially benefit from the proposed method in lifecycle management due to the added efficiency provided by the characteristics of this method. The interoperability in information exchange has a major role in efficient information integration and sharing.

(6) Disaster management

The ability to retrieve required information by applying queries on BrIM database speeds up information extraction in case of disaster. Time is the most valuable asset in disaster management. Therefore, benefiting from the interoperability of the proposed method has a great impact on the successful disaster management (Jahromi et al., 2013). In addition, in case of a disaster, the root-cause investigation would be faster and more facilitated for post disaster forensic investigations.

3.5.1 INSPECTION INFORMATION CAPTURE METHODS

Based on the proposed method, providing the means of interacting with the information model allows for an immediate object-oriented information collection and leads to an updated BrIM which provides an effective and immediate access to inspection records and leads to a more efficient and precise information collection. Furthermore, the updated information model equipped by inspection observations can be used to provide more precise condition assessment, structural analysis, etc.

The inspection of an infrastructure may consist of multiple levels in which the inspection sessions and the details of inspection tasks at each level are defined by the applicable codebook of inspection. As explained in Section 2.3.2, level one bridge inspection has to be done by a certified bridge inspector. The inspector not only has to have the skills to work with relevant instruments and measurement equipment, but also he or she must be able to interpret the inspection results based on codebook guidelines. Further inspections and NDTs may be applicable based on discretion of the inspector. New research has led to new technologies and methods for inspection data capturing which are explored in multiple examples in Section 2.3.4; however, these new methods of inspection data capturing are yet to become the common practice (e.g., image processing and subsurface NDTs).

3.6 EXTENSION MODEL FOR INSPECTION DATA INCORPORATION IN BRIM

Interoperability issues in data exchange through the lifecycle of infrastructure necessitate a standard data model. On the other hand, several attempts have been done in BIM in

order to effectively tackle interoperability in the AECOO industry with a method of adding, managing, exchanging, and sharing information through out the lifecycle. As explained in Section 2.4.3, IAI was founded to develop IFC as a standard information model for the AECOO industry. IFC is designed to satisfy not only the interoperability demand but also an extensible data structure. In spite of these attempts in developing IFC; it does not cover all object models in its data structure. The major reason for this flaw is the excessively complex work of modeling all the building/structure objects. Besides, new concepts and components are being proposed to be added to IFC over time. Thus, the extensible architecture of IFC allows incremental expansion of this information model in a manageable way. Also, the non-proprietary characteristic of IFC creates a better potential for the integration of information from various areas and being an object-oriented model allows coupling data with the correspondent components.

3.6.1 NECESSITY OF INCORPORATING INSPECTION DATA DEFINITIONS IN BRIM

IFC is designed to satisfy not only the interoperability demand but also an extensible data structure. Although IFC does not define bridge components specifically, its extensibility character justifies the utilization of IFC model for tackling the interoperability issues in bridge management. Based on the defect incorporation method, the detected defects on bridge components are identified as objects in the information model of the bridge and are considered as special type of components of the bridge. In order to be able to add defects to the information model, the data structure of the model should be extended to incorporate the different defect types and their associated properties. The data of the

defect models are essential for recording the inspection results, tracking defect propagation and also for maintenance planning purposes.

This research aims to add different types of defects to the BrIM with their specific relationships to other components. The required properties to be added to the information model are extracted from the inspection codebooks, which provide the required inspection data that should be gathered by inspection forms.

3.6.2 INSPECTION DATA STRUCTURE

Inventory, inspection and maintenance are three modules of O&M data repository. Inventory data define the bridge inventory and include the items which are used to collect information on the overall condition of the bridge and its components (e.g., structure type, material, geometric data and navigation data). These inventory data are usually permanent items that should be verified and updated during each inspection. Inspection data includes various types of data that are associated to each specific component of the bridge and may vary based on the detected defect (e.g., defect type, defect geometry data, etc.), however, the ratings of the inspected component are based on a unified definition in a range of 1 to 9 that is described in Table β-1. Condition rating assists in the comparison of the current bridge condition with the as-built condition of the bridge at the commencement of its service. Maintenance data including component repair data, affect the component rating (e.g., repair material).

Table 3-1 Condition rating system (BIM Inspection Manual, 2008)

Rating	Condition	Description	Maintenance Priority
9	Very Good	New condition	No repairs
8	Very Good	Almost new condition.	No repairs
7	Good	Could be upgraded to new condition with very little effort.	No repairs
6	Good	Generally good condition.	No repairs
5	Adequate	Acceptable condition and functioning as intended	No repairs
4	Adequate	Below minimum acceptable condition.	Low priority
3	Poor	Presence of deterioration. Not functioning as intended.	Medium priority for replacement, repair.
2	Poor	Hazardous condition or severe distress or deterioration.	High priority for replacement, repair, and/or signing
1	Immediate Action	Danger of collapse and/or danger to users.	Bridge closure, replacement, repair, and/or signing required as soon as possible
N	Not Accessible	Component cannot be visually inspected.	

3.6.3 REQUIREMENT ASSESSMENT AND EXTENSION PROCESSES FOR INSPECTION DATA

DEFINITIONS

IFC standard 2x4, which is the latest version of IFC standard (IFC, 2013), is used as the basis for the extension model. Data architecture, definitions and entities of IFC 2x4 are used to assess the extension of the standard with keeping an eye on the level of expansion of the IFC model through reusing existing property sets and relationships which can be matched to current defect definition.

A comprehensive requirement assessment has been done by reviewing multiple bridge inspection and management codebooks prior to proposing the extension of IFC standard in order to identify required definitions of inspection data to be added. These resources include but not limited to several bridge inspection manuals (e.g., Alberta bridge inspection reference manual, Ontario structure inspection manual, etc.) and various bridge management systems (i.e., Alberta BMS, Quebec BMS, Pontis and European BMSs). Associated tasks of the requirement assessment are the categorization of each

inspection data into various data types (e.g., structural inventory data and inspection data) which is explained in Section 3.6.2. Also, different types of defects which must be recorded in inspection reports and their corresponding properties are identified based on inspection codebooks (e.g., width, length, depth and orientation as the properties of a crack). Finally, the required relationships of detected defects with the hosting component are defined, such as subtraction relationship of a spalling defect with its hosting column. Moreover for identifying relationships among defects and bridge components the technical attributes of various defect types have been studied to identify the required relationships to be added to a defect model in IFC standard.

3.6.4 IFC-DEFECT

As explained in Section 2.3.3, defect types for each bridge structure type (e.g., concrete, steel) require a diverse range of enumerations for various defect types (e.g., flexure crack, shrinkage crack, spalling, etc.). In the process of adding new components to the IFC definitions, the *IfcBuildingElementProxy* is the entity which is commonly used and has been defined in IFC 2. For example, newly added bridge elements to IFC are defined by *IfcBuildingElementProxy* since this entity does not have a predefined meaning of a special type of building element. IFC hierarchy for this entity is shown in Figure 3-6. However, the definition and characteristics of *IfcBuildingElementProxy* do not comply with the notion of a defect in this context. In this research a defect is defined as a discontinuity of structure or material which exceeds its specified criteria in the codebook (e.g., a discontinuity with the width of 0.1 mm or more is considered a crack based on Section 2.3.3). Hence, the proposed IFC extension model for defects is added under the

IfcVoidingFeature which matches the definition and attributes of a defect. This entity is added to the IFC standard in its latest version. Based on IFC (2013), *IfcVoidingFeature* is defined as a modification of an element which reduces its volume. Such a feature may be caused by inlays into the formwork of cast members made of materials such as concrete.

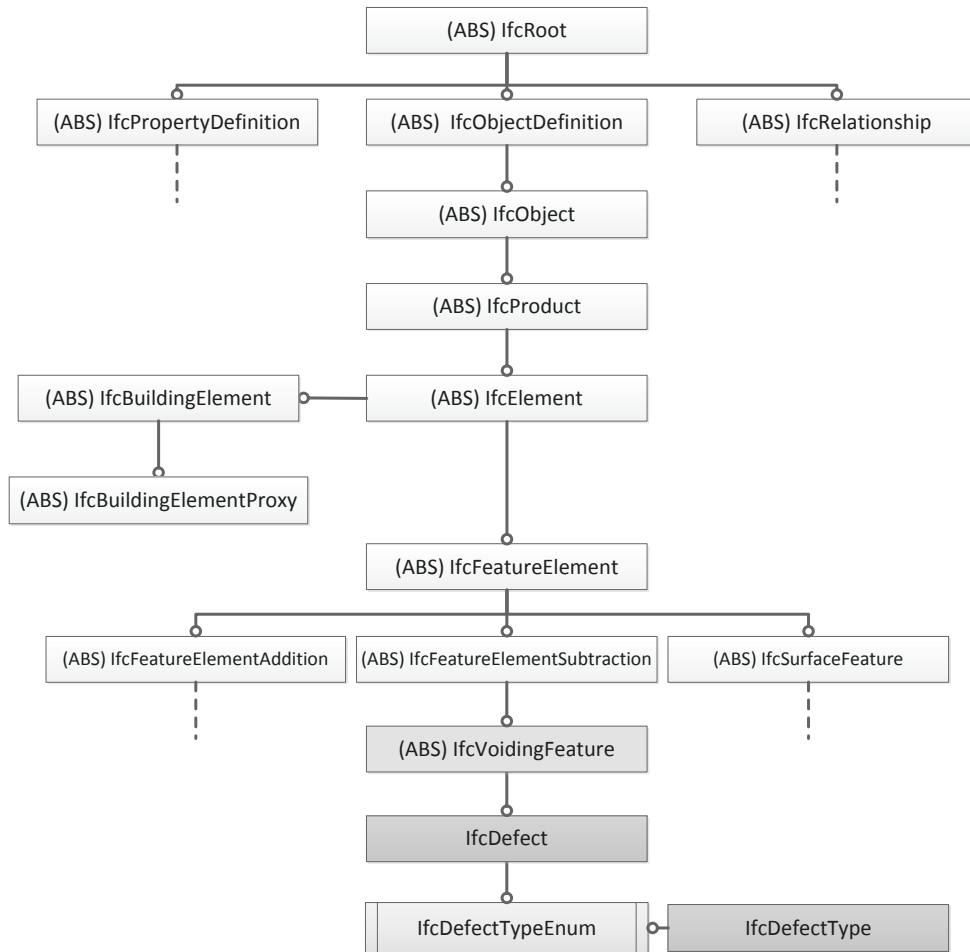

Figure 3-6 Proposed IFC hierarchy for IFC-Defect

Defects are defined under the *IFC Product Extension* schema as a part of the *Core Layer* of the IFC model. A new type (i.e., *DefectType*) is proposed to be defined in IFC with seven enumerations: (1) Shrinkage crack, (2) Flexural crack, (3) Shear crack, (4) Scaling,

(5) Spalling, (6) Delamination and (7) Collision Damage. Figure β-6 shows the hierarchy of entities for the *IFC-Defect*. Other possible types of defects can be added to this enumeration in the future.

3.6.5 IFC-DEFECT PROPERTIES DEFINITION

As explained in Section β.6.3, defect types which must be recorded in inspection reports and their corresponding properties are identified based on inspection codebooks (e.g., width, length, depth as the properties of a crack).

The properties of *IfcDefect* are defined according to property set assignment concept of the IFC (IFC, 2013). Reusing the existing defined property sets in IFC prevents the redundant extension of the IFC model. All the property sets of IFC standard are reviewed. Table β-2 represents the applicable property sets among the existing property sets in IFC standard to be reused in the proposed extension.

Table β-2 Shared property sets for IFC-Defect

Name of PropertySet	Description	Pertinent inspection data
Pset_ActionRequest	An action request is a request for an action to fulfill a need.	Immediate actions request (e.g., road closer, subsurface inspection)
Pset_Condition	Determines the state or condition of an component at a particular point in time.	Condition assessment.
Pset_ActorCommon	A property set that enables further classification of actors, including the ability to give a number of actors to be designated as a population.	Inspector's proficiency category.
Pset_Permit	A permit is a document that allows permission carry out work in a situation where security or other access restrictions apply.	Road or lane closure permits properties.
Pset_TransportComponentCommon	Properties common to the definition of all occurrences of IfcTransportComponent.	Inspection access equipment (e.g., scissor lift)

Table β-3 represents the defined properties of various defects and their pertinent explanation. As it can be observed, not all properties are applicable to all defect types. The defined properties are categorized in three groups based on their geometry configuration including: (1) Linear defects (e.g., various types of cracks), (2) Planar defects (e.g., delamination), and (3) Volumetric defects (e.g., spalling). The proposed property items are placed in four property sets including: (1) Pset_DefectCommon, (2) Pset_DefectLinear, (3) Pset_DefectPlanar, and (4) Pset_DefectVolumetric.

Table β-3 Defined properties of defects for IFC-Defect

Property	Description	Example	Linear	Planar defects	Volumetric defects	Common
Defect Type	Various types of deficiencies associated with concrete	Flexure Cracks	✓	✓	✓	✓
Inspector's name	Name of responsible person for inspection	Jim Smith	✓	✓	✓	✓
Date of inspection	Date of inspection	15.06.2013	✓	✓	✓	✓
Last Inspection date	Last preformed inspection date	01.07.2012	✓	✓	✓	✓
Next inspection date	May be changed based on inspector's discretion	01.07.2014	✓	✓	✓	✓
Average length	Length of detected defect	2.7 inch	✓	✓	✓	✓
Average width	Width of detected defect	0.005 inch	✓	✓	✓	✓
Average depth	Depth of detected defect	0.015 inch	✓		✓	
Section loss	Percentage of section loss	17%		✓	✓	
Deformation	Amount of misalignment	2 inch	✓	✓	✓	✓
Diameter	Diameter approximate circle which covers deficiency	2 inch		✓	✓	
Severity	Severity level of deficiency	Light or minor scale	✓	✓	✓	✓
Further NDT requirement	Inspector may require subsequent tests	Yes	✓	✓	✓	✓
NDT method	Required method of NDT	UT	✓	✓	✓	✓

Defect model location definition

The proposed extension models the location of *IfcDefect* entities through the existing methods of IFC standard (IFC, 2013). Location definition is done in by three ways in IFC: (1) Absolute location definition uses an axis placement, relative to the world coordinate system; (2) Relative location definition uses an axis placement, however the axis is relative to the object placement of another product (e.g., the host bridge component which the defect is placed on); (3) Grid reference system defines the location by the virtual intersection and reference direction given by two axes of a grid. *IfcObjectPlacement* is an abstract supertype for the special types defining the object coordinate system (IFC, 2013).

Defect model relationships definition

The proposed method utilizes two relationships defined in IFC standard for defining the relationships between the defect model and the host component of bridge model: (1) *IfcRelConnectsElements* defines an objectified one to one physical or logical connectivity relationship. The connectivity is defined by the shape representation of the connection geometry of the connected entities (e.g., connection of flexure crack model to deck model surface), and (2) *IfcRelVoidsElement* defines an objectified host component and an opening component that creates a void in the host component (IFC, 2013). This relationship is used to identify the void relationship for defects which cause a void on the host component.

3.7 4D VISUALIZATION OF INSPECTION DATA

The essential requirement for risk forecast and progress management in O&M management is the infrastructure depreciation tracking and information collection about the current situation of the infrastructure. Immediate access to an updated source of information is an evident requirement in order to achieve the aforementioned goals. Accessibility to health condition timeline of infrastructure allows more accurate risk forecasting and consequently, leading to an informed resource allocation and corrective actions.

This research suggests the integration of defect models with the date of inspection. The linkage of time data with the 3D model of the bridge using available 4D visualization software programs allows the stakeholders to monitor the impact and propagation of structural defects.

The proposed approach also suggests the integration of the maintenance schedule with the 3D model of the bridge which allows a 4D visual representation of the O&M phase of the bridge lifecycle. By forming the linkage between BrIM and timing information, the model simulates the maintenance, replacement and rehabilitation processes and allows preventive actions for process improvement. The visualization of the linked schedule to the information model facilitates the maintenance planning and enables the maintenance managers to keep track of the health condition of the bridge.

3.8 SUMMARY AND CONCLUSIONS

This research proposed a method of adding the defect models to the BrIM through an interactive process in order to visualize inspection data. This method aims to improve the O&M processes of bridges by eliminating the redundant data exchange steps, and improving the inspection documentation and data storage. The proposed method not only considers the integration of the defects information with the 3D model, but also suggests the steps of interaction of the inspector with the BrIM on the inspection site. This method is also applicable to maintenance planning and management. Furthermore, 4D visualization of defect propagation is proposed based on inspection data.

In order to tackle the interoperability and extensibility issues of the proposed method, extending IFC as a communication language among a large number of stakeholders involved in the lifecycle management of a bridge was proposed. Thus, various defect-related definitions and properties are identified and proposed in IFC as a necessary part of the extensibility process.

Moreover, a lifecycle management framework with a cross-phase, cross-layer BrIM as an information repository and sharing center was proposed for integrating the BrIM with GIS to enhance bridge lifecycle management processes at the network-level.

CHAPTER 4 IMPLEMENTATION AND CASE STUDY

4.1 INTRODUCTION

The case study is implemented using the design and inspection data of an overpass in Alberta to validate our proposed approach. In this case study, the inspection observations are integrated with the BrIM model of the bridge. The information model of the bridge is created based on the created drawings and documents of as-built changes. The sample defect models are created and their properties are defined. The IFC model of the BrIM is created and the Express code pertinent to the proposed extension is added to it.

In order to validate the 4D visualization of the inspection data, the date of inspection is added to the defect models and the required modifications are implemented to visualize the propagation of defects on the BrIM. Additionally, the 3D model of the bridge is geo-referenced and placed on the map to facilitate the network-level processes of the bridge management.

4.2 IMPLEMENTATION

As explained in Section 2.4.1, the conventional approach of O&M data management in practice has various limitations including difficulties in data sharing, errors in communication among various domains involved in the project and information losses within the same domain. In addition, due to interoperability obstacles, redundant data input reaches to seven times before a construction project completion (Sjogren and

Kvarsvik, 2007). As explained in Section 3.5, one of the main objectives of the proposed method is to substantially reduce these types of redundancies of documentation activities.

Alberta Transportation (AT) applies data inventory and management using three main databases, i.e., Bridge Information System (BIS), Culvert Inventory System (CIS) and Bridge Inspection and Maintenance System (BIM₂). Figure 4-1 represents the process flow of AT database update based on BIS User Guide (2010). In this system, the BIM₂ module exchanges data with two other databases and enables case-specific inspection report generation based on the bridge type, inspection type and the inspected component attributes. The inspection forms are fielded by the inspector at the inspection site and transformed to the data management department for digitizing the data as well as the management of data input. Later, these new data will be added to the BIM₂ database (BIM Inspection Manual, 2008).

The received data pertinent to the bridge used in the case study include numerous inspection reports added by the inspector at the inspection site and digitized by the data management department. The reports include various types of inspection including level one, CHL₂ and CSE, alongside the design drawings and as-built changes reports. The available images pertinent to the inspection of the bridge in the BIM₂ database are included in the data. Examples of the inspection reports and sketches and figures are available in Appendix 1.

Autodesk Revit Architecture 2014 is selected to develop the BrIM model for the case study and for defect modeling since it is one of the most widely used information

modeling software in the market (Lucy, 2011). Although Autodesk Revit 2014 does not include bridge components, Civil Structures (Autodesk, 2014) extension automatically generates a wide range of common infrastructure components and structures including roads and bridges inside Revit. This allows modeling a bridge information model and at the same time taking advantage of the family concept in Revit which allows for extending BrIM by modeling an undefined component in BrIM (e.g., spalling) and integrating its information in the model to keep the BrIM an object-oriented model through the extension. Besides, family concept in Autodesk Revit allows us to define newly designed BIM objects and integrating them with the 3D model of the bridge. Moreover, using a single program minimizes the interoperability problems which arise through the model transfer between various software programs.

4.3 DEFECT MODEL DEVELOPMENT

The most common way of defect representation in the state-of-the-practice is the paper reports which are filled by the inspector at the inspection site. Also, the picture of the defected area must be attached to the report if it is demanded in the inspection procedure. This method of collecting inspection information requires redundant and time-consuming process of gathering this information in a database. Besides, the probability of error will increase.

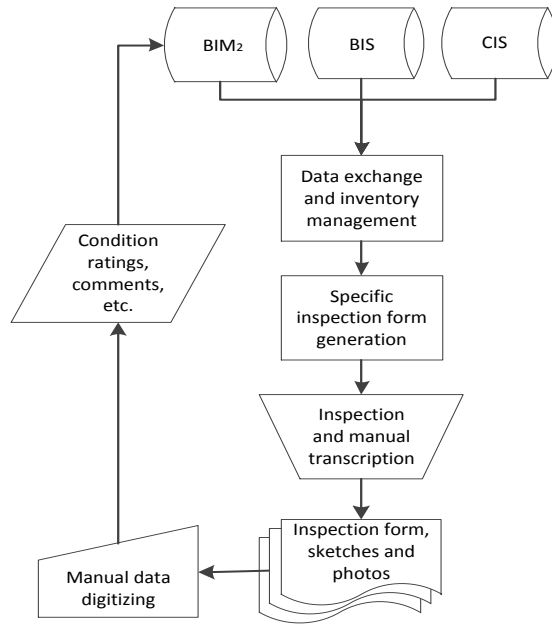

Figure 4-1 Process flow of Alberta Infrastructure and Transportation database update

Based on the proposed method, the representation of defects would be a part of the bridge 3D model as an information object. This integration of the defect model into the bridge 3D model will result in numerous benefits including a facilitated inspection process and reduced probability of errors. In addition, an updated 3D model of the bridge containing defects representation and information allows 4D visualizing and analyzing the changes in damages and defect on the infrastructure and results in a long-term lifecycle management of bridges.

The components of a model in Revit are considered as elements. For better understanding of Revit categorization and classification of elements, Figure 4-2 (a) shows the element hierarchy of the Revit and Figure 4-2 (b) represents the hierarchy of the predefined defect families. The defect families are added under the Generic model. These families can have

multiple types and each type can have multiple instances. This categorization becomes more helpful in assigning properties to each specific family model in terms of providing a control on the parameters (e.g., geometric parameters, material, etc.). Each parameter can be defined at various extent of inclusion including *instance parameters* which affect a single instance of a family or *type parameters* which affect instances of a specific type. Then, all the defined parameters in the family editor interface should be entitled either as family parameters that are limited to the family editor interface, or as shared parameters which are created in an external text file and can be transferred among various Revit projects or exported to other application programs (e.g., Microsoft Project) (Autodesk, 2014).

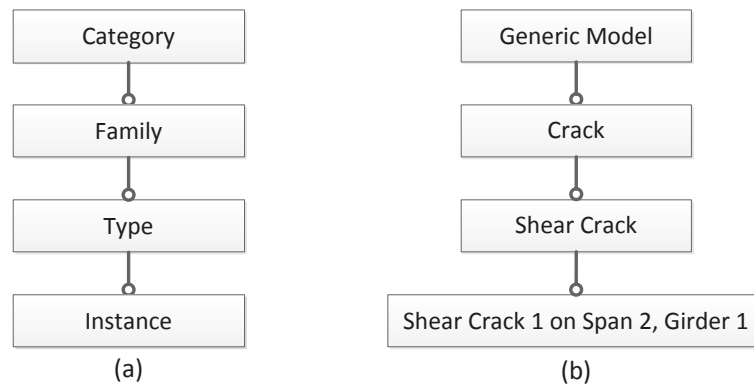

Figure 4-2 (a) Element hierarchy of the Autodesk Revit, (b) Hierarchy of the proposed families (Adapted from Autodesk, 2014)

Figure 4-3 illustrates the class and subclass of the proposed predefined defect families in Revit classification. Defect families are developed under the *components* which have to be assigned by the host subclass and the *model* class itself is an *element* (Autodesk, 2014).

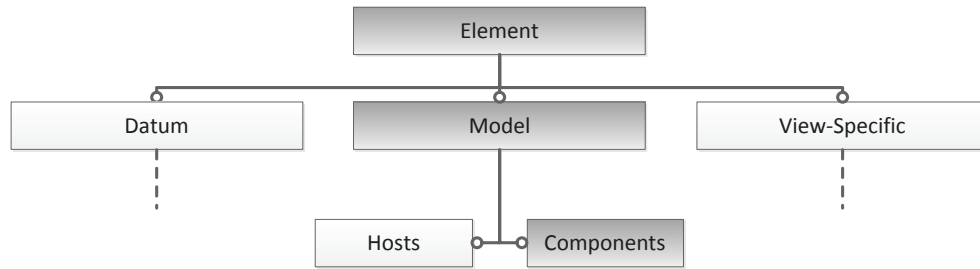

Figure 4-3 Class and Subclass of the proposed predefined defect families, (Adapted from Autodesk, 2014)

Properties assigned to the developed defect models use the shared parameters concept in Revit, which allows gathering and sharing the same parameter among various projects and families without losing the defined parameters as well as transferring the parameters to schedules. Moreover, multiple formulas are written for the required parameters to fulfill the required model objectives.

The case study implementation has been narrowed down to concrete structures as discussed in Section 2.3.3. A list of predefined defects is developed in the family interface of Revit. All the mentioned defects of concrete structures in Section 2.3.3 are modeled to be available in the predefined listing of defects, namely, crack, delamination, scaling, spalling, and collision damage.

These defects on bridge structures can be the result of various causes and they may have different irregular shapes. For the modeling of the predefined defects the shape categorization of IFC properties definition aforementioned in Section 3.6.5 has been used, i.e., linear defects (i.e., various crack types), planar defects (i.e., scaling and delamination), and volumetric defects (i.e., spalling and collision damage). As explained earlier in this section each family is defined under a specific category in the hierarchy of

components in Revit. The template of the family defines its category and the hosting behavior of the defect model which has to be chosen at the beginning of the development process. Hence, all the potential family templates have been reviewed and the *Generic Model Face-Based* is chosen for linear defects and *Generic Model Adaptive* is chosen for the planar and volumetric defect families.

Table 4-1 Review of embedded behavior and attributes of family templates (Autodesk, 2014)

Revit Family Templates	Non-Hosted (Free Standing)	Host					Massing Environment			Special	Default Settings					
		Face	Wall	Floor	Ceiling	Roof	Free Standing	Adaptive	Pattern Based	Line Based	Dedicated to particular host	Cuttable	Work Plane-Based	Always vertical	Cut with voids when loaded	Shared
<i>Furniture System.rft</i>	✓													✓		
<i>Furniture.rft</i>	✓													✓		
<i>Specialty Equipment.rft</i>	✓													✓		
<i>Specialty Equipment wall based.rft</i>			✓													
<i>Generic Model.rft</i>	✓										✓		✓			
<i>Generic Model Adaptive.rft</i>	✓							✓			✓					✓
<i>Generic Model ceiling based.rft</i>					✓						✓					
<i>Generic Model face based.rft</i>		✓									✓					
<i>Generic Model floor based.rft</i>				✓							✓					
<i>Generic Model line based.rft</i>									✓		✓					
<i>Generic Model Pattern Based.rft</i>								✓			✓					✓
<i>Generic Model roof based.rft</i>						✓					✓					
<i>Generic Model wall based.rft</i>			✓								✓					
<i>Casework.rft</i>	✓										✓					
<i>Casework wall based.rft</i>			✓								✓					

(1) **Linear defect models:** The prism shape is chosen to represent the crack model as a linear defect. Although this shape does not always represent the exact crack shape, it is the closest resembling shape to cracks. The geometry of this model can be adjusted either approximately by dragging, stretching and rotating the model or accurately by filling the geometric properties of the model with exact values through various defined geometry constraints shown in Table β -3. The orientation of a crack is related to the crack cause from technical point of view. To control the angle exactly in the model, it is assigned to the crack model as a parameter.

Furthermore, with a combination of multiple prisms it is possible to get closer to the natural shape of multidirectional cracks. Figure $\#$ -4 (a) represents the shared properties assigned to the developed crack model and Figure $\#$ -4 (b) represents the crack model.

(2) **Planar defect models:** A predefined polygon plane with adaptive corner constraints is developed to represent the planar defects (i.e., scaling and delamination) with minor depth to be reported in inspection (e.g., the distance between two separated layers of material in delamination). Figure $\#$ -4 (c) represents the planar defect model with adaptive constraint points which enables the inspector to control the defect shape.

(3) **Volumetric defect models:** In order to model the irregular volumetric shape of spalling defects and collision damages, a polyhedral is chosen equipped with an adaptable convex polygon base face. As shown in Figure $\#$ -4 (d), the base face corners are adaptive constraint points. The inspector is able to control the shape of the face base

and the defect model depth by entering the value of the depth parameter while the model's base face is drawn by the adaptive points at the corners.

The devolved families are benefiting from the available technologies in an innovative way to implement a new concept. Adaptive points have never been used to form the irregular shapes of defects. This innovative usage of these points enables fast and easy modeling of an irregular mass voids by drawing an irregular base face of the mass while keeping the defined depth parameter of the void approximately. However, these representations have more room for improvement in the future to get closer to the actual shape of defects with more detailed information.

4.4 BRIM MODEL UPDATE WITH INSPECTION INFORMATION

Based on the proposed framework, the modeled BrIM becomes the ultimate database of the whole lifecycle of the bridge. The proposed method suggests interaction of the inspector with the BrIM through a handheld device as described in Section 3.3. The proposed solution should be easy-to-use and practical. Available applications are utilized in an innovative way to demonstrate the practicality of the proposed method with least investment and effort. Based on the proposed method, the model should be updated incrementally during the lifecycle of the bridge. The BrIM of the bridge is modeled based on the drawings and the inspection reports and the trends in defect changes are highlighted.

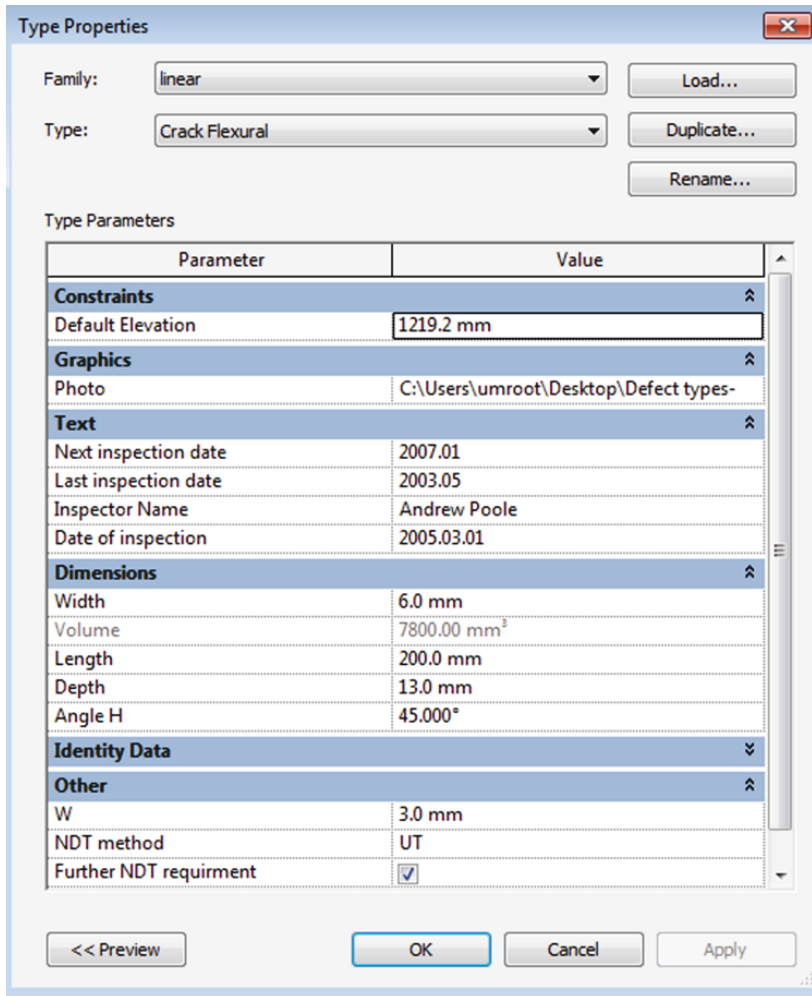

(a) Assigned properties of a crack model in project interface

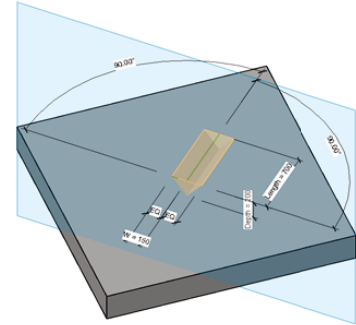

(b) Crack model before adaption

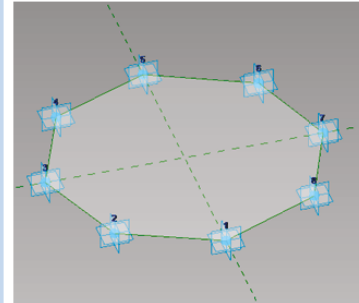

(c) Planar defect model before adaption

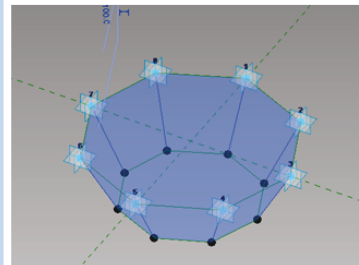

(d) Volumetric defect model before adaption

Figure 4-4 Adaptive defect models in family editor interface before adaption and assigned properties developed in project interface

Defect images are matched with their pertinent data in the inspection reports and various observed defect are modeled, using the developed system. An example of inspection reports and a list of utilized abbreviation of AT are included in Appendix 1. Figure 4-5 represents the 3D view of the modeled bridge. Figure 4-6 represents the integration of the bridge inspection data with BrIM. The red circle in the figure represents the adapted spalling defect model based on the inspection report data and the image of the defect.

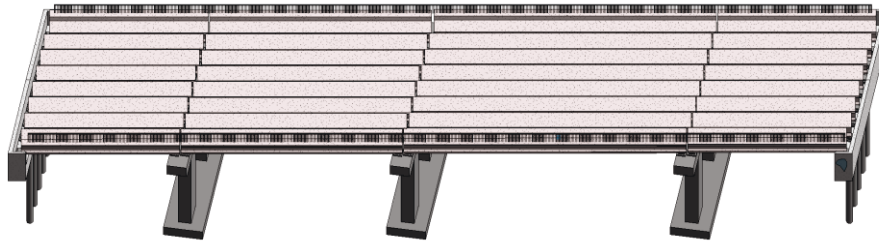

Figure 4-5 3D view of the modeled bridge

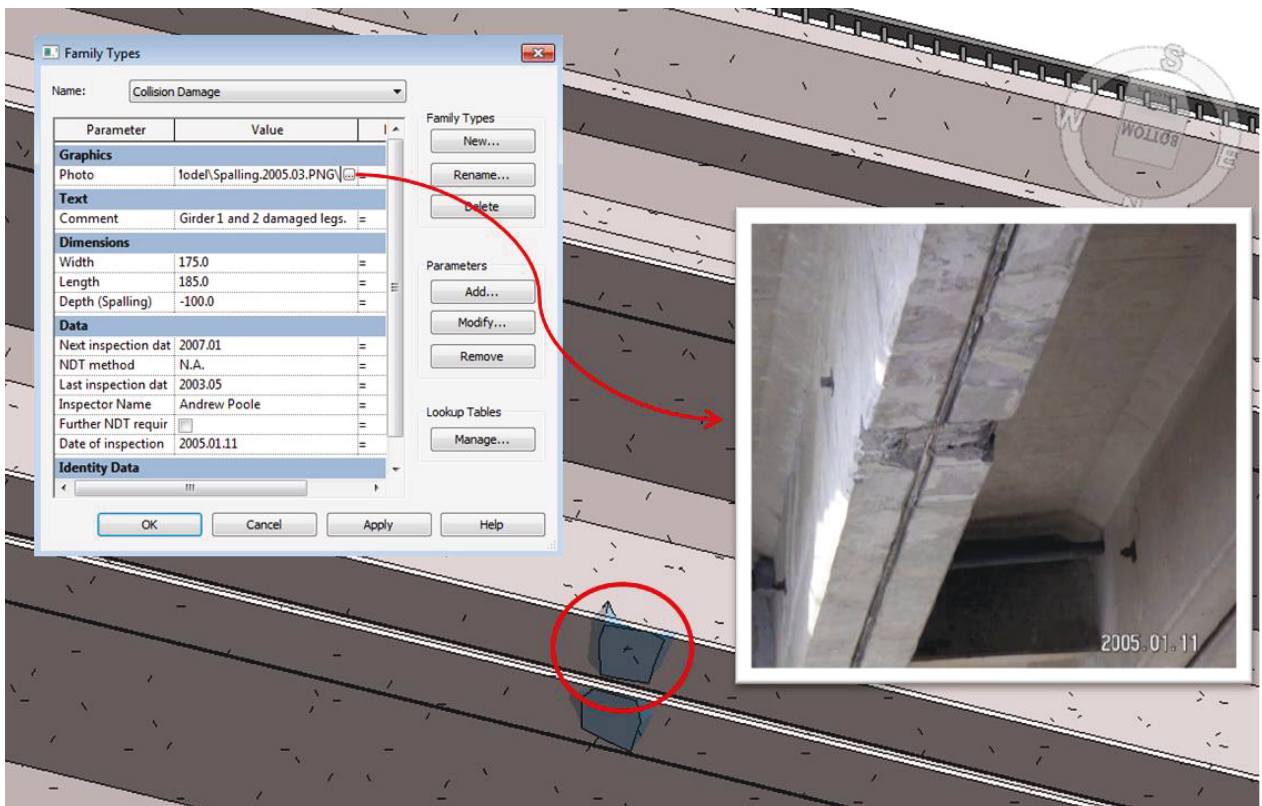

Figure 4-6 Integration of bridge O&M data with BrIM

4.5 4D VISUALIZATION OF DEFECT PROPAGATION

Defect progress management bears a substantial importance because of the increased need for infrastructure depreciation tracking. Immediate access to an updated source of information is an evident requirement in order to achieve the aforementioned goals.

As mentioned in Section 3.7, this research aims to integrate defect models to the bridge information model, which incorporates different information types including the date of inspection. The linkage of time data with the 3D model of the bridge using available 4D visualization software programs allows the stakeholders to monitor the propagation of structural defects.

This integration is conducted in Navisworks 2012 (Autodesk, 2014) on the exported BrIM model of the bridge from Revit 2014. The *Date of inspection* parameter of the defect models, which is defined previously in the case study, is used as a schedule to form the 4D visualization of the defect models. Figure 4-7 (a), (b) and (c) represent the defect propagation. Figure 4-7 (d) shows the Lines display mode. The color coding in the simulation represents the *Date of inspection* parameter as the discovery date of the defect with gray color and the *Last inspection date* parameter as the occurrence date of defect with the white color. The assumption is that the defect occurred sometime between the last inspection date and the current inspection date. However, for simplicity it is assigned to the last inspection date.

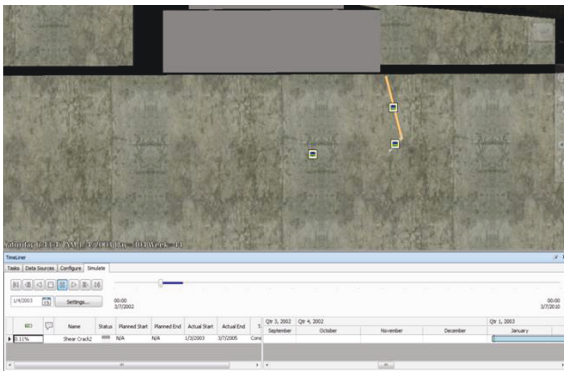

(a) Wide shoe crack on abutment inspected on 01/03/2003

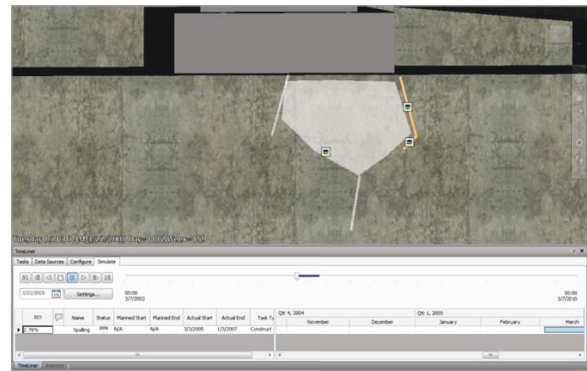

(b) Spalling and shoe crack occurred on 03/07/2005

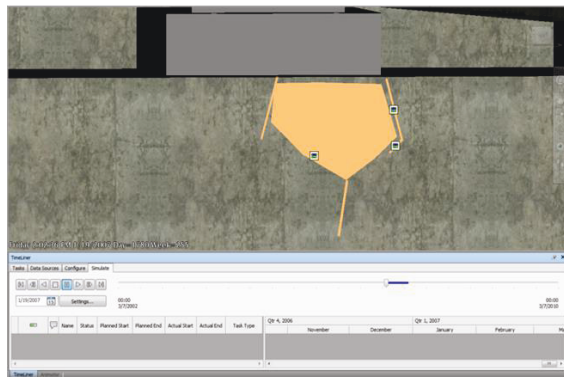

(c) Spalling and shoe crack inspected on 01/03/2007

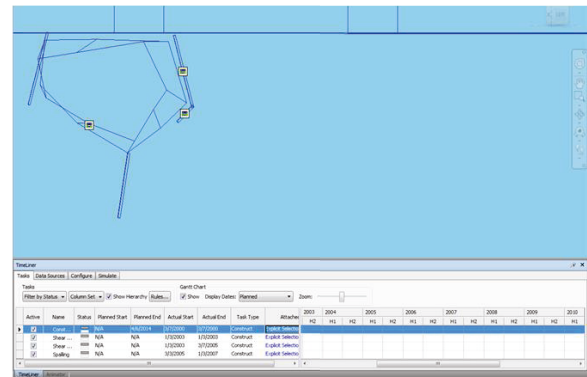

(d) Lines display mode for 3D view

Color coding
 White: Last inspection date parameter as the occurrence date of defect.
 Gray: Date of inspection parameter as the discovery date of the defect.

Figure 4-7 4D visualization of defect propagation by using linked time dimension to defect models

4.6 GIS INTEGRATION WITH BRIM

For the network-level use of the BrIM database, an easy-to-access management tool and using a GIS-based BMS component is necessary as explained in Section 3.2 and in the *Value Adding Benefits* in Section 3.5. There are various ways of geo-referencing a 3D model and placing it in a worldwide web-based network or in a limited-access network. One method is by exporting the model as a drawing file (.dwg) and geo-referencing the BrIM model in software programs like Sketchup Pro (Trimble, 2014), then publishing it on Google Earth (Google, 2014) map. However, due to interoperability problems with the

BrIM software programs, the GIS-based model transfer merely takes place as a graphical representation and not as an information model. Hence, benefitting of the advancements of BIM technology, publishing higher level of information becomes possible due to various add-in programs for BIM applications which resolve the interoperability issues. The advantage of BIM tools usage repeatedly shows the maturity of BIM and justifies the use of the BIM tools for the development of other infrastructure information models. Figure 4-8 shows the export process of all Revit elements in the bridge model to the map including defect families as *Generic Models* which indicates the family template shown in Table 4-1.

In this research the Globe Link add-in (Autodesk, 2014) for Revit 2014 is used to streamline the linkage between the map and the project services. This add-in allows publishing and updating building information models directly from Revit into Google Earth mapping service and site information can be acquired from Google Earth mapping service and imported into Revit 2014 software applications for network-level planning and site layout purposes. Globe link keeps all the components of the BrIM model including families. Figure 4-9 shows the Geo-referenced BrIM model published on Google Earth.

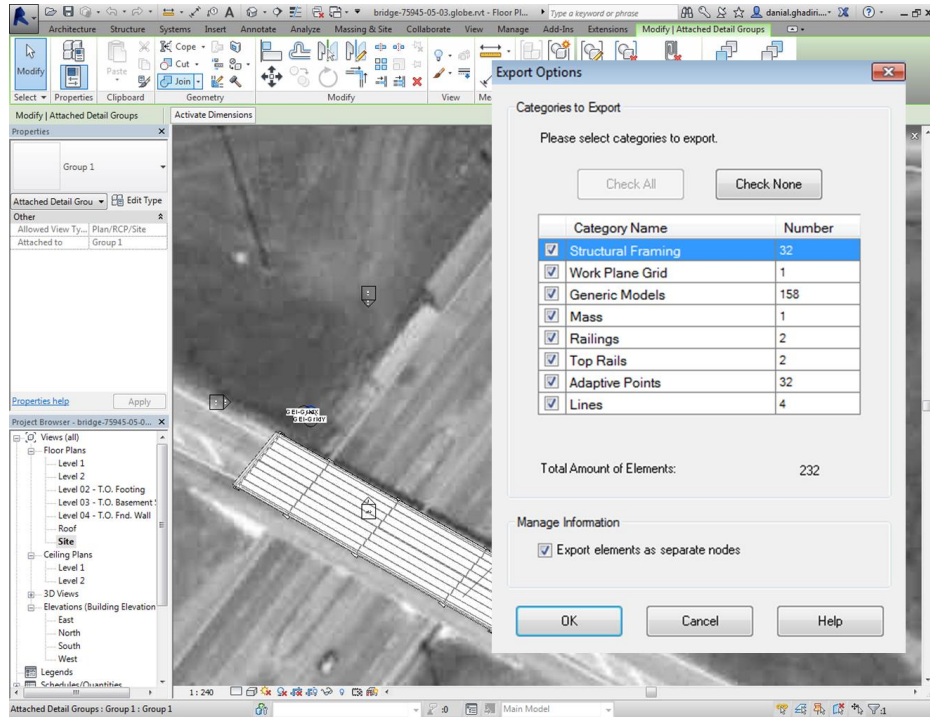

Figure 4-8 Export process of all Revit elements in the bridge model to the map



Figure 4-9 Geo-referenced BIM model published on Google Earth map

4.7 IFC EXTENSION: RELATIONSHIP DEFINITION USING EXPRESS LANGUAGE

The BrIM model of the bridge has been designed in Revit and also the models of defects are created in the Family interface of Revit. The required attributes are associated with the defect models to explore the feasibility of the proposed IFC extension model. The model was exported in IFC format and this IFC file was the basis for IFC extension evaluation. The required Express code pertinent to the extension process is written and added to the IFC file based on IFC 2x4. Eventually, the extension of the IFC model is checked by the IFC viewer applications including Nemetschek IFC viewer (Nemetschek, 2014) and DDS-CAD Open BIM viewer (Data Design System, 2014). However, in order to validate the defined relationships for defect models, the use of *IfcBuildingElementProxy* entity is inevitable for defect model definition instead of *IfcVoidingFeature* since the proposed *IfcVoidingFeature* is defined in the latest version of IFC standard and IFC viewer applications are not updated. Figure 4-10 represents the void relationship between a delamination defect and a pier in DDS-CAD Open BIM viewer.

Table 4-2 represents a portion of EXPRESS code for the model. The relationships of modeled defects with the hosting component are also defined in this extension. As an instance the physical relationship of *IfcRelConnectsElements* defines physical attachment of *Crack Flexural* model to *M_Pier_horizontal_cap_rectangle_columns_cf* model. Also, *IfcRelVoidsElement* entity defines the representation of a void by *Crack Flexural* on the host component *M_Pier_horizontal_cap_rectangle_columns_cf*.

Table 4-2 Part of EXPRESS code for the model

EXPRESS Code	Comment
/* Definitions */	
#31761= IFCVOIDINGFEATURE('3GqGV0KX09uH_s08wb0RX',#41,'linear:Crack Flexural:327092',\$','Crack Flexural',#31760,#31751,'327092',.CUTOUT.);	Definition of <i>Crack Flexural</i>
#32857= IFCVOIDINGFEATURE('3i5mBvZunDshhI7CMdCb1y',#41,'linear:Crack Shear:331108',\$','Crack Shear',#32856,#32847,'331108',.CUTOUT.);	Definition of <i>Crack Shear</i>
#31890= IFCVOIDINGFEATURE('3GqGV0KX09uH_s08wbVhj',#41,'Planar:Delaminatio n:328120',\$','Delamination',#31889,#31880,'328120',.CUTOUT.);	Definition of <i>Delamination</i>
#33646= IFCVOIDINGFEATURE('3i5mBvZunDshhI7CMdCb2G',#41,'Volumetric:Spalling :331144',\$','Spalling',#33645,#33636,'331144',.CUTOUT.);	Definition of <i>Spalling</i>
#32685= IFCVOIDINGFEATURE('3GqGV0KX09uH_s08wbVoa',#41,'Volumetric:Collisio n:329713',\$','Collision',#32684,#32675,'329713',.CUTOUT.);	Definition of <i>Collision</i>
/* Coordinates */	
#31753= IFCCARTESIANPOINT((- 23032.1321703933,42106.0987828572,680.600069292307));	Coordinates of <i>Crack Flexural</i>
#32677= IFCCARTESIANPOINT((- 40024.0158733491,42137.2881578261,528.212959877827));	Coordinates of <i>Collision</i>
/* Physical Relationships */	
#44233=IFCRELCONNECTSELEMENTS('2Ftkl0rdHFTQpKhjrnuvOk',#41,\$,\$,\$, #21102,#31761);	Attachment of <i>Crack Flexural</i> to <i>M_Pier_horizontal_cap_rectangle_</i> <i>columns_cf</i>
#44234=IFCRELVOIDSELEMENT('2Fjll0rkHFTQpKsbonuvOk',#41,\$,\$,#21102,# 31761);	Void relationship which defines representation of a void by <i>Crack</i> <i>Flexural</i> on the host component <i>M_Pier_horizontal_cap_rectangle_</i> <i>columns_cf</i>
/* Properties Values */	
#31779= IFCPROPERTYSINGLEVALUE('Date of inspection',\$,IFCTEXT('15.08.2013'),\$);	Date of inspection
#31896= IFCPROPERTYSINGLEVALUE('Further NDT requirement',\$,IFCBOOLEAN(.F.),\$);	Further NDT requirement
#31781= IFCPROPERTYSINGLEVALUE('Depth',\$,IFCLENGTHMEASURE(20.),\$);	Depth
/* Property Sets Definitions */	
#44235=IFCPROPERTYSET('GUID',#41,'Pset_Condition',\$(#31779,#31896));	Pset_Condition
#44236=IFCPROPERTYSET('GUID',#41,'Pset_DefectVolumetric',\$(#31781));	Pset_DefectVolumetric
/* Relating Property sets to components */	
#44237=IFCRELDEFINESBYPROPERTIES('GUID',#41,\$,\$,(#32685),#44236);	Relating <i>Pset_DefectVolumetric</i> to <i>Collision</i>

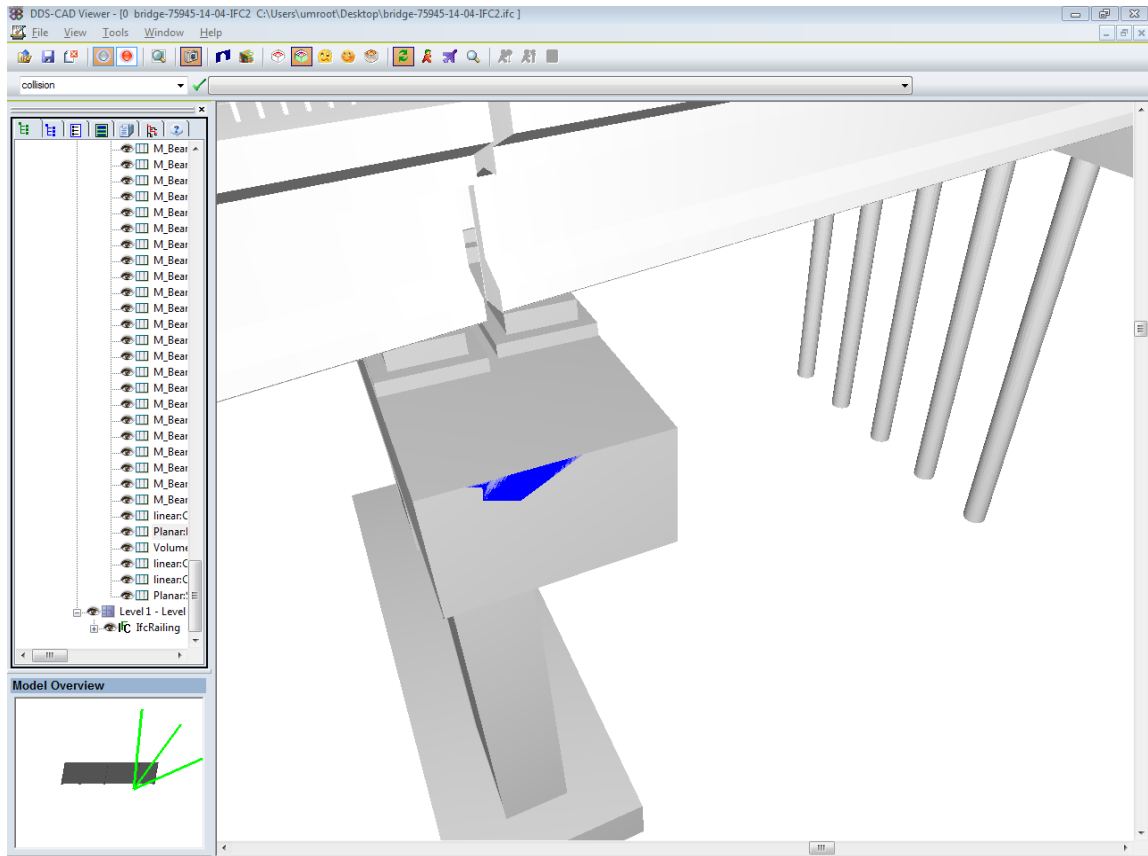

Figure 4-10 Representation of void relationship between delamination and pier in DDS-CAD Open BIM viewer

4.8 SUMMARY AND CONCLUSIONS

The case study evaluated the practicality of the proposed method, using available tools and programs, and benefitting from the advancement of BIM technology. The case study was implemented using the design and inspection data of an overpass in Alberta to validate the proposed approach. In this case study, the inspection observations were integrated with the BrIM model of the bridge. The BrIM model of the bridge was created based on the drawings and the documents of the as-built model. The required defect

models were developed and their properties were defined. The IFC model of the bridge model was generated and the Express code pertinent to the proposed extension was added to the IFC model.

The 4D visualization of the inspection data was implemented by adding the date of inspection to the defect models, and the required modifications were implemented to visualize the propagation of the defects on the BrIM. Additionally, the 3D model of the bridge was geo-referenced and placed on the map to facilitate the network-level processes of bridge management.

CHAPTER 5 CONCLUSIONS AND FUTURE WORK

5.1 SUMMARY OF RESEARCH

This research proposed a method of adding the defect models to the BrIM through an interactive process in order to visualize inspection data. This method aims to improve the O&M processes of bridges by eliminating the redundant data exchange steps, and improving the inspection documentation and data storage. The proposed method not only considers the integration of the defects information with the 3D model, but also suggests the steps of interaction of the inspector with the BrIM on the inspection site. This method is also applicable to maintenance planning and management. Furthermore, 4D visualization of defect propagation was proposed based on inspection data by linking the time dimension and the BrIM inspection information.

In order to tackle the interoperability and extensibility issues of the proposed method, extending IFC as a communication language among a large number of stakeholders involved in the lifecycle management of a bridge was proposed. Thus, various defect-related definitions and properties are identified and proposed in IFC as a necessary part of the extensibility process.

Moreover, a lifecycle management framework with a cross-phase, cross-layer BrIM as an information repository and sharing center was proposed for integrating the BrIM with GIS to enhance bridge lifecycle management processes at the network-level.

The case study evaluated the practicality of the proposed method, using available tools and programs, and benefitting from the advancement of BIM technology. The case study

was implemented using the design and inspection data of an overpass in Alberta to validate the proposed approach. In this case study, the inspection observations were integrated with the BrIM model of the bridge. The BrIM model of the bridge was created based on the drawings and the documents of the as-built model. The required defect models were developed and their properties were defined. The IFC model of the bridge model was generated and the Express code pertinent to the proposed extension was added to the IFC model.

The 4D visualization of the inspection data was implemented by adding the date of inspection to the defect models, and the required modifications were implemented to visualize the propagation of the defects on the BrIM. Additionally, the 3D model of the bridge was geo-referenced and placed on the map to facilitate the network-level processes of bridge management.

5.2 RESEARCH CONCLUSIONS

The conclusions of this research are as follows: (1) A method of adding the defect models to the BrIM was proposed through an interactive process of inspection data visualization. This research can improve O&M processes of the bridge by eliminating the redundant data exchange steps, improving the inspection documentation and data storage, and visualizing inspection data; (2) 4D visualization of defect propagation based on inspection data is an effective method for tracking the defect; (3) The interoperability and extensibility issues of the proposed method were tackled by emphasizing the use of IFC concept and proposing the *IFC-Defect* model; (4) A lifecycle management framework

was proposed with a cross-phase, cross-layer BrIM as an information repository and sharing center; and (5) This research innovatively uses the available tools, technologies and advancements for implementing the proposed method.

5.3 LIMITATIONS AND FUTURE WORK

The limitations of this research are as follows: (1) Existing IFC viewer applications do not support the newly defined IFC extensions; hence, the 3D presentation of the IFC entities pertinent to the newly defined extensions will require updating the IFC viewer applications; (2) The behavior of the inner surface of the defect models using Generic Model Adaptive template (Section 4.2) of the family editor interface can be irregular for complex defects and do not maintain the same depth for a specific volumetric defect; and (3) Adding defect models on curved surfaces causes the distortion of the defect model or the misalignment of the defect model with its host component surface.

In addition to addressing the above-mentioned limitations, our future work will also include the following: (1) The inclusion of bridge inspection data of other types of bridge structures, such as steel structures; (2) The automatic integration of subsurface NDT visualizations with BrIM for instant update of BrIM; (3) The inclusion of other types defects (e.g., deformation and misalignment) in the *IFC-Defect* enumeration; and (4) The integration of remote surface scanning methods (e.g., image processing) with the proposed method for automatic generation of defect models.

REFERENCES

- Adhikari, R. S., Moselhi, O., and Bagchi, A. (2014). "Image-based retrieval of concrete crack properties for bridge inspection." *Automation in Construction*, 39(0), pp.180-194.
- Akcamete, A., Akinci, B., and Garrett, J. (2010). "Potential utilization of building information models for planning maintenance activities." *Proceedings of the International Conference on Computing in Civil and Building Engineering*, Carnegie Mellon University, USA.
- Akinci, B., Tantisevi, K., and Ergen, E. (2004). "Assessment of the capabilities of a commercial 4D CAD system to visualize equipment space requirements on construction sites." *Construction Research Congress*, pp. 989-995.
- AT (2014). Alberta Transportation. Retrieved January, 2014, from:
<https://extranet.infra.gov.ab.ca/infra_login.html>.
- Autodesk (2014). Autodesk Revit. Retrieved April, 2014, from:
<<http://usa.autodesk.com/>>.
- Bisby, L.A. and Briglio, M.B. (2004). "ISIS Canada Educational Module No. 5: An Introduction to Structural Health Monitoring", ISIS Canada, pp.3.
- Bray, T., Paoli, J., Sperberg-McQueen, C. M., Maler, E., and Yergeau, F. (1997). "Extensible markup language (XML)." *World Wide Web Journal*, 2(4), pp.27-66.
- Bentley Systems (2014). Retrieved Jan 2014, from InspectTech:
<<http://www.bentley.com/en-US/Products/InspectTech>>.

- BIM Inspection Manual (2007), “Bridge Inspection and Maintenance System Level 2 Inspection Manual” Version 1.1, Alberta, Alberta Infrastructure and transportation.
- BIM Inspection Manual (2008), “Bridge Inspection and Maintenance System Level 1 Inspection Manual” Version 3.1, Alberta, Alberta Infrastructure and transportation.
- BIM Reference Manual (2007), “Bridge Inspection and Maintenance System Reference Manual” Version 3.0, Alberta, Alberta Infrastructure and transportation.
- BIRM (2012), “Bridge Inspector's Reference Manual”, Volume 2, U.S. Department of Transportation.
- BIS User Guide (2010), “Bridge Information System (BIS) for Inspection Consultants”, Release 3.0, User Guide version 3.1, Alberta Transportation.
- Cartz, L. (1995). “Nondestructive testing”, ASM International, Materials Park, USA.
- Chen, S., Liu, W., Bian, H., and Smith, B. (2013). “3D LiDAR Scans for Bridge Damage Evaluations.” Sixth Congress on Forensic Engineering, ASCE, 487-495.
- Chen, S. S., Li, J., Tangirala, V., Shirole, A., and Sweeney, T. (2006). ”Accelerating the Design and Delivery of Bridges with 3D Bridge Information Modeling: Pilot Study of 3D-Centric Modeling Processes for Integrated Design and Construction of Highway Bridges”. Washington, D.C. USA, NCHRP-IDEA Program Project Final Report, No 108.
- Chen, S. S., and Shirole, A. M. (2006). “Integration of information and automation technologies in bridge engineering and management: Extending the state of the

art.” Transportation Research Record: Journal of the Transportation Research Board, 1976(1), pp.3-12.

Data Design System (2014), DDS-CAD Open BIM Viewer. Retrieved April, 2014, from:
< <http://www.dds-cad.net/>>.

East, E. W. (2007). ”Construction Operations Building Information Exchange (COBie): Requirements Definition and Pilot Implementation Standard”, No. ERDC/CERL TR-07-30. Engineer research and development center Champlain IL construction engineering research lab.

Fleming, Q. W., and Koppelman, J. M. (2000). “Earned value project management” Proceeding in Project Management Institute Pennsylvania, Upper Darby, Pa., USA, pp.19-23.

Frangopol, D. M., Kong, J. S., and Gharaibeh, E. S. (2001). “Reliability-based life-cycle management of highway bridges.” Journal of Computing in Civil Engineering, 15(1), pp.27-34.

Gagnon M., Gaudreault V. and Overton D. (2008). “Age of Public Infrastructure: A Provincial Perspective” Minister responsible for Statistics Canada.

Gallaher, M.P., O’Connor, A.C., Dettbarn, J.L. and Gilday L.T. (2004). Cost analysis of inadequate interoperability in the US capital facilities industry, NIST Publication GCR, pp.04-867.

Google (2014). Google Earth. Retrieved April, 2014, from:
<<http://www.google.com/earth/>>.

- Green, M., and Cebon, D. (1994). "Dynamic response of highway bridges to heavy vehicle loads: theory and experimental validation." *Journal of Sound and Vibration*, 170(1), pp.51-78.
- Hammad, A., and Motamedi, A. (2007). "Framework for lifecycle status tracking and visualization of constructed facility components." *7th International Conference on Construction Applications of Virtual Reality*, pp. 224-232.
- Hammad, A., Vahdatikhaki, F., Albahri, A., Salimi, S., Moghaddam, D.G., Jahromi, A.N., (2013). *Framework for Life-cycle Infrastructure Information Modeling and Management*. Montreal, 4th Construction Specialty Conference, No 93.
- Helmerich, R., Niederleithinger, E., Algernon, D., Streicher, D., and Wiggenhauser, H. (2008). "Bridge inspection and condition assessment in Europe." *Transportation Research Record: Journal of the Transportation Research Board*, 2044(1), pp.31-38.
- Hu, Y., and Hammad, A. (2005). "Location-based mobile bridge inspection support system." *Proceedings of the 1st CSCE Specialty Conference on Infrastructure Technologies, Management and Policy*, Toronto, Canada, FR(130), pp.1-10
- IFC (2013). *Industry Foundation Classes Release 4 (IFC4)*. Retrieved May, 2013, from: <http://www.buildingsmart-tech.org/ifc/IFC4/final/html/index.htm>.
- Industry Canada (2013). *Industry Canada - Gross Domestic Product Transportation and Warehousing (NAICS, pp 48-49)*. Retrieved on Oct, 2013, from: <http://www.ic.gc.ca/cis-sic/cis-sic.nsf/IDE/cis-sic48-49vlae.html>.

- Isikdag, U., Aouad, G., Underwood, J., and Wu, S. (2007). "Building information models: a review on storage and exchange mechanisms." Bringing ITC knowledge to work, 24th W78 Conference Maribor 26(29.6), pp.135-143.
- Isikdag, U., Underwood, J., and Aouad, G. (2008). "An investigation into the applicability of building information models in geospatial environment in support of site selection and fire response management processes." Advanced Engineering Informatics, 22(4), pp.504-519.
- Jahromi, A.N., Hammad, A., Moghaddam, D.G., (2013). Supply Chain Pre- and Post-Disaster Management Using Visual Analytics: The Case of Canada-U.S. Border Crossings. Montreal, 4th Construction Specialty Conference, No 93.
- Kang, J. H., Anderson, S. D., and Clayton, M. J. (2007). "Empirical study on the merit of web-based 4D visualization in collaborative construction planning and scheduling." Journal of Construction Engineering and Management, 133(6), pp.447-461.
- Kansai (2014). Remote Concrete Crack Measurement System. Retrieved March, 2013, from: <<http://www.kankou.co.jp/en/kumonos/index.html>>.
- Khanzode, A., and Fischer, M. (2000). "Potential Savings from Standardized Electronic Information Exchange: A Case Study for the Steel Structure of a Medical Office Building" CIFE Technical Report #I21, Center for Integrated Facility Engineering Stanford University.

- Khemlani, L. (2004). "The IFC building model: A look under the hood." Retrieved November, 2013, from AECbytes Feature:
<<http://www.aecbytes.com/feature/2004/IFCmodel.html>>
- Kluth, M., Borrmann, A., Rank, E., Mayer, T., & Schiessl, P. (2008). "3D building model-based life-cycle management of reinforced concrete bridges." *eWork and eBusiness in Architecture, Engineering and Construction (ECPPM)*, pp.291-300.
- Kolbe, T. H., Gröger, G., Nagel, C., and Häfele, K. (2012). "OpenGIS City Geography Markup Language (CityGML) Encoding Standard", Version 2.0. Reference No: OGC 12-019, International OGC Standard.
- Koo, B., and Fischer, M. (2000). "Feasibility study of 4D CAD in commercial construction." *Journal of Construction Engineering and Management*, 126(4), pp.251-260.
- Kyle, B.R., Vanier, D.J., Kosovac, B., and Froese, T.M. (2002). "Visualizer: An interactive, graphical, decisions-support tool for service life prediction for asset managers." *Proceedings of the 9th International Conference on Durability of Building Materials and Components, Brisbane, Australia. 9DBMC, Paper 183*, pp. 1-9.
- Liebich, T. (2009). "IFC 2x Edition 3 Model Implementation Guide Version 2.0." Retrieved on Nov, 2013, from Dresden: Building SMART International Modeling Support Group: <<http://www.iai-tech.org/>>.

- Lounis, Z., and Daigle, L. (2008). "Reliability-based decision support tool for life cycle design and management of highway bridge decks." Annual Conference of the Transportation Association of Canada, pp.1-19.
- Lucy, J. (2011). Welcome to the world of BIM. Electrical Wholesaling. Retrieved September, 2013, from: <<http://ewweb.com/e-biz/welcome-world-bim>>.
- Lukas, K., and Borrmann, A. (2012). "Integrated Bridge Management from 3D-Model to Network Level." In proceeding of the 6th International Conference on Bridge Maintenance, Safety and Management. Lake Como, Italy.
- Mayes, R. L., Buckle, I. G., Kelly, T. E., and Jones, L. R. (1992). "AASHTO seismic isolation design requirements for highway bridges." Journal of Structural Engineering, 118(1), pp.284-304.
- McCann, D. M., and Forde, M. C. (2001). "Review of NDT methods in the assessment of concrete and masonry structures." NDT & E International, 34(2), pp.71-84.
- Minor, J., and Derucher, K. N. (1992). "Bridge maintenance inspection and evaluation." CRC Press, pp. 8.
- Mirza, S. (2006). "Durability and sustainability of infrastructure-a state-of-the-art report." Canadian Journal of Civil Engineering, 33(6), pp.639-649.
- Murdock, J. W. (1965). "A report of investigation conducted by the engineering experiment station of the University of Illinois: A critical review of research on fatigue of plain concrete." Project IHR-73 Illinois Cooperative highway research program, No.34.

- Nemetschek (2014). Nemetschek IFC viewer. Retrieved April, 2014, from:
<<http://www.nemetschek.com/en/home.html> >.
- OAGO (2009). "Office of the Auditor General of Ontario (OAGO) Annual Report"
Chapter 3, pp.83, Retrieved May, 2013, from:
<http://www.auditor.on.ca/en/reports_en/en09/302en09.pdf >.
- Palos, S., Kiviniemi, A., and Kuusisto, J. (2013). "Future perspectives on product data management in building information modeling." *Construction Innovation: Information, Process, Management*, 14(1), pp.52-68.
- Ryall, M. J. (2010). "Bridge management" 2nd Ed., Butterworth-Heinemann, Oxford.
- Sack, D. A., and Olson, L. D. (1995). "Advanced NDT methods for evaluating concrete bridges and other structures." *NDT and E International*, 28(6), pp.349-357.
- Sacks, R. (2002). "Can parametric 3-D computer-modeling prevent errors in Precast Construction?" National Convention of the Precast/Prestressed Concrete Institute (PCI), Nashville, USA.
- Silano, L. G. (1993). "Bridge inspection and rehabilitation: a practical guide." Wiley. USA. pp.xi.
- Sjogren, J., and Kvarsvik, K. (2007). "BuildingSMART standards -information and demonstration." EUREKABUILD Workshop, Norway.
- Small, E. P., Philbin, T., Fraher, M., and Romack, G. P. (1999). "Current status of bridge management system implementation in the United States." 8th International Bridge Management Conference, Vol.2.

- Streicher, D., Algernon, D., Wöstmann, J., Behrens, M., and Wiggenhauser, H. (2006).
“Automated NDE of post-tensioned concrete bridges using imaging echo methods.”
Proceedings of the 9th European Conference on NDT pp.25-29.
- Statistics Canada (2013). “Statistics Canada - Gross Domestic Product at Basic Prices, by
Industry (monthly)”. Retrieved on Oct. 2013, from:
<<http://www.statcan.gc.ca/tables-tableaux/sum-som/l01/cst01/trade26-eng.htm>>.
- Trimble (2014). SketchUp Pro . Retrieved April, 2014, from:
<<http://www.sketchup.com/>>.
- Thompson, P. D., Merlo, T., Kerr, B., Cheetham, A., and Ellis, R. (1999). “The new
Ontario bridge management system.” 8th International Bridge Management
Conference. pp. F-6/1-15.
- Thompson, P. D., Small, E. P., Johnson, M., and Marshall, A. R. (1998). “The Pontis
bridge management system.” Structural Engineering International, 8(4), pp.303-
308.
- Van Nederveen, S., Bergmann, O., Malmkvist, M., RWS, B. K., Lebègue, E., and Fies,
B. (2013). “Inventory of available information exchange standards.”
Rijkswaterstaat, Netherlands .
- Vanlande, R., Nicolle, C., and Cruz, C. (2008). “IFC and building lifecycle
management.” Automation in Construction, 18(1), pp.70-78.
- Wolfgram, L. (2005). “Optimization of Bridge Management and Inspection
Procedures.” National Science Foundation Grant EEC, 139017.

Yabuki, N., Lebegue, E., Gual, J., Shitani, T., and Zhantao, L. (2006). "International collaboration for developing the bridge product model IFC-Bridge." Proceedings of the Joint International Conference on Computing and Decision Making in Civil and Building Engineering, Montréal, Canada. pp. 1927-1931.

Yan, J. X. (2008). "A Survey of the State of Bridge Management in Canada."

Zhiliang, M., Zhenhua, W., Wu, S., and Zhe, L. (2011). "Application and extension of the IFC standard in construction cost estimating for tendering in China." Automation in Construction, 20(2), pp.196-204.

APPENDIX 1

SAMPLE OF THE MODELED BRIDGE INSPECTION REPORTS

Alberta Transportation

Bridge Inspection & Maintenance System (Web 2005)

75945 -1 Bridge

Bridge Inspection												
Bridge File Number	75945 -1 Bridge				Form Type	PSR						
Year Built/Year Supstr	1966/1966				Lot No.	2						
Bridge or Town Name	INNISFAIL				Inspector Name	Owen Salava						
Located Over	2:22 L1 27.931;2:22 R1 27.920				Inspector Class	BR CLS A						
Located On	590:02 C1 0.224				Assistant Name							
Water Body Cl./Year					Assistant Class							
Navigabil. Cl./Year					Inspection Date	13-Mar-2013						
Legal Land Location	NW SEC 22 TWP 35 RGE 28 W4M				Data Entry By	Marcia Chavez						
Longitude, Latitude	-113:55:53, 52:01:35				Data Entry Date	26-Mar-2013						
Road Authority	Alberta Transportation (AIT)				Reviewer Name	John O'Brien						
Contract Main. Area	CMA19				Review Date	16-Mar-2013						
Clear Roadway/Skew	12.2 / -10 deg. (LHF)				Dept. Reviewer Name	Chris Black						
AADT/Year	3,370 / 2011 (A)				Dept. Review Date	28-Mar-2013						
Road Classification	RAU-213.4-120				Follow-Up By							
Detour Length (km)	5											
Allowable Load (t):	Single	CS1 38 GIRDER	Semi	CS2 52 GIRDER	Train	CS3 71 GIRDER	---> On Critical Spans --->Critical Member					
Design Loading:	HS20								---> Primary Span			
Posting Information												
Required Vert. Clearance Posting (m)	UNDER: 2 L1 5.3m, 2 R1 5.3m											
Posted Vertical Clearance (Y/N)	Yes											
Posted:	Lane	NB	On Bridge (m)	5.3	In Advance (Y/N)	Yes	Lane	SB	On Bridge (m)	5.2	In Advance (Y/N)	Yes
Remarks												
Required Load Posting (t)	Single				Semi				Truck Train			
Posted Loading (t)	Single				Semi				Truck Train			
Posted:	Lane	EB	At Junction (Y/N)	No	In Advance (Y/N)	No	At Bridge (Y/N)	No				
Posted:	Lane	WB	At Junction (Y/N)	No	In Advance (Y/N)	No	At Bridge (Y/N)	No				
Remarks	Not required.											
Hazard Marker At Bridge (Y/N)	No											
Remarks												
Other Sign Types												
Utilities (Located at)												
Utility Attachments												
Telephone	At West.				Gas							
Power	Light standards all 4 corners.				Municipal							
Others					Problem (Y/N)		No					
Remarks												
Approach Road												
			Last	Now	Explanation of Condition							
Horizontal Alignment			6	6	Typical overpass crest curve and intersection ramps.							
Vertical Alignment			6	6								
Roadway Width (m)	12.600				Potholes in approach ACP.							
Approach Bump			6	6								
Guardrail (Y/N)	Yes				SW transition missing 1 connector bolt.							
Guardrail			6	6								
Length (m)	95.000											
Current Standard (Y/N)	Yes											
Termination Type	Turn Down											
Drainage			6	4	Icing on both abuts under finger jnts.							
Approach Road General Rating			6	6								

Superstructure				
Bridge Component		Last	Now	Explanation of Condition
(Primary Span : FC, 4 Spans, Lengths(m): 12.2-16.8-21.3-12.2, A-Ident Number:)				
Special Features				
Special Feature		X	7	S3G1
(Type : HIGH LD BUMPER)				
Special Feature		X	7	
(Type : EXT LATER POST TENS)				
Wearing Surface/Deck Top Detail Ratings				
	N (%)	1 (%)	2 (%)	3 (%)
Last	0	0	0	0
Now	10.0	0.0	0.0	0.0
Wearing Surface		5	5	Chip seal on concrete.
(Material Type : CONCRETE - CONVENTIONAL CHIP SEAL COAT)				
(Thickness(mm) : 50)				
Lateral Connection Problem (Y/N)	No			
Deck Top		N	N	
Deck Rideability		7	7	
Deck Joints		3	3	14 plow guards broken. Abut joint plumbing plugged with gravel at W.; overflowing onto abutment seats. Ripped gland at P3.
Temperature (deg. C)	-2			
(Expansion Type : FINGER PLATES;GLAND (WABO-MAUER, TRANSFLEX, ETC))				
(Fixed Type : GLAND (WABO-MAUER, TRANSFLEX, ETC))				
Gap Size (mm)	Gap Location			
35	E. abut - Finger			
38	W. abut - Finger			
78	E. pier			
74	W. pier			
70	C. pier			
Deck Drainage		7	4	Abut plumbing spills onto seats. Shallow delams around weep tubes at U/S deck. P2 drain outlet is above the cap. Pier caps have cracks & corrosion stains.
Drains Clogged (Y/N)	Yes			
Curbs/Median		4	4	Exterior fascia of curb delaminating on approximately 3%.
(Curb Type : Standard)				
Scaling (Percent Area)	10			
Bridge Rail		4	4	7th rail from SW has 3 vertical bars damaged. Anchor bolts short on 20%. Post grout 5% deteriorated.
(Type : GALVANIZED STEEL VERTICAL BAR)				
Bridge Rail Posts		4	5	
(Type : GALVANIZED POST STEEL;GALVANIZED POST STEEL)				
Bridge Rail/Posts Coating		8	8	
(Type : GALVANIZED)				
Sidewalk		X	X	
Girder Detail Ratings				
	N (count)	1 (count)	2 (count)	3 (count)
Last	0	0	0	0
Now	0	0	0	0

Superstructure				
Bridge Component		Last	Now	Explanation of Condition
(Primary Span : FC, 4 Spans, Lengths(m): 12.2-16.8-21.3-12.2, A-Ident Number:)				
Girders		5	5	S2G4,6,9 have rust spots by underside; S3G1,4-6 same. Numerous typical shoe cracks 15%. S2G1 has HLD.
Cracking (Y/N)	Yes			
Spalling (Percent Area)	0			
(Number Of Girders : 36)				
Diaphragms/Cross Frame		5	5	15% of diaphragms have bottom delam.
Bearings		5	5	Roller bearing A1 & A2. Choo choo bearings P1 & P3. P2
Temperature (deg. C)	-2			
(Expansion Type : ROLLER BEARING)				
(Fixed Type : PINNED BEARING)				
Coating Adequate (Y/N)	No			
Functioning (Y/N)	No			
Deck Underside		5	5	Deck underside has shallow delams, 300mm dia., around weep tubes; other weep tubes have stains.
Stains (Percent Area)	1			
Span Alignment Problems				
Vertical (Y/N)	No			
Horizontal (Y/N)	No			
Superstructure General Rating		5	5	
Substructure				
Bridge Component		Last	Now	Explanation of Condition
Abutments				
Bearing Seats/Caps		7	7	Ice on NE bearing seat.
(Type : CONCRETE)				
Backwalls/Breastwalls		8	8	
Wingwalls		8	8	
Piles		N	N	
Paint/Coating		4	4	Coating fading, peeling.
Abutment Stability		8	8	
Scour/Erosion		X	X	
Piers/Bents				
(Type : PIER-COLUMN)				
Bearing Seats/Caps		5	5	Very minor delam N end of P3 on E face & at S end of P1. Cracks at ends of all piers with some corrosion staining. Ice and corrosion stain at N end of P3 cap.
(Type : CONCRETE)				
(Total Number of Bearing Piles : 0:0:0)				
Pier Shaft/Piles		7	7	
Bracing/Struts/Sheathing		X	X	
Nose Plate		X	X	
Paint/Coating		7	5	Some peeling at wetted areas at ends.
(Colour Description :)				
(Colour Code :)				
Pier Stability		8	8	
Scour		X	X	
Debris (Y/N)	No			

Substructure				
Bridge Component		Last	Now	Explanation of Condition
Substructure General Rating		5	5	
Structure Usage				
		Last	Now	Explanation of Condition
Grade Separation				
Road Alignment		9	9	
Traffic Safety Features		9	9	
Type	Guardrail			
Slope Protection		5	5	Ice on NE and S slope protection. W gap 110mm, top is sloped backwards; E gap 70mm & 112mm. Sloped backwalls at top.
(Type : CONCRETE; CONCRETE)				
Bank Stability		6	6	Concrete retaining walls at P1 & P3.
Drainage		7	7	
Grade Separation General Rating		6	6	

Maintenance Recommendations						
Inspector Recommendations	Year	Inspector Comments	Department Comments	Target Year	Est. Cost	Cat #
REPAIR/REPLACE BRIDGE RAIL	2013	Repair 1 section of vertical bar rail.				
GALVANIZE/PAINT BRIDGE RAIL						
SEAL CURBS	2013	Patch spalled areas, 0.3m3 OH-V.				
PATCH DECK						
SEAL DECK						
OVERLAY DECK						
REPAIR/REPLACE DECK JOINTS	2013	Reseat or replace P3 gland. Replace broken plow guards.				
RESET/ PAINT BEARINGS						
WASHING	2013	Finger plumbing plugged, clean out W trough.				
SHOTCRETE REPAIRS						
REPAIR ABUTMENT SCOUR/EROSION						
PLACE ADDITIONAL RIP RAP						
REMOVE DRIFT ACCUMULATION						
OTHER ACTION	2013	Extend drain near N end of P2.				
OTHER ACTION	2013	Extend weep tubes.				
OTHER ACTION	2013	Patch potholes at approaches.				
OTHER ACTION	2013	Patch HLD chips S2G1.				
OTHER ACTION	2013	Install transition bolt at SW.				
OTHER ACTION	2013	Reseal abuts/piers where degraded.				
OTHER ACTION						
OTHER ACTION						
OTHER ACTION						
Structural Condition Rating (Last/Now) (%)	55.6/55.6	Sufficiency Rating (Last/Now) (%)	53.7/54.3	Est. Repl. Yr	2023	Maint. Req'd. (Y/N) Yes
Special Comments for Next Inspection	slope protection can go another several years before repair if water controlled. Bottom of slope protection contained by retaining walls.		Department Comments			
Maintenance Reviewed By			Date		Estimated Total	0
Proposed Long-Term Strategy						
On 3-Year Program (Y/N)						
Proposed Action						
Previous Inspector's Name	Owen Salava	Previous Assistant's Name				
Next Inspection Date	13-Dec-2014	Previous Inspection Date	12-Aug-2011			
Inspection Cycle (Default) (months)	21					
Comment						

5. Span 4 girder 1 scale at weep drains - typical.



6. SE slope protection icing on bearing seat. Gap at top of east slope protection.

7. Icing at NE bearing seat and slope protection.



8. Span 4 girder 4 wide shoe crack, typical roller condition.

9. North end of pier 3 icing, corrosion stains, cracks at girder 8/9 bearing area.



10. Span 4 south curb spalling, exposing rebar.

11. Wheel path pothole at abut
2 joint, EBL.



12. Missing plow guards, ripped
gland at pier 3 gland WBL.

 <p>CH2MHILL Project Number: 438071</p>	<p>Bridge Inspection Report Highway 2 Overpass Near Innisfail (Hwy. 590)</p>	<p>Bridge File: 75945 Inspection Date : 13-Mar-13 Inspected By: Owen Salava</p>
---	---	---

13. Damaged rail panel, 7th panel from SW.



14. Missing SW transition connection bolt.

15. Icing at abut 1 slope protection, gap at bench, typical bearing seat sealant condition.



16. High load chips to span 2 girder 1 over outside lane.

17. South end pier 1 minor delamination at drip guard, cracking near bearing.



18. Pier 2 north end cracked on west face.

APPENDIX 2

SAMPLE OF AT INSPECTION REPORT CODING

STEEL BEAMS	Code	STEEL TRUSSES (ETC)	Code	TIMBER	Code
Rolled Beams	RB	Pony-Truss	PT	Untreated-Beam	UT
Rivetted Plate Girder	RG	Other Types (Do Not USE. Temporary Holding Area Only)	SS	Other Types	XT
Welded Girder	WG	Bailey Bridge	SSB		
		Steel Arch	SSA		
		Suspension	SSS		
RailCar,Other Beams	RC	Through Truss	TH		

PRESTRESSED	Code	PRECAST	Code	CIP-CONCRETE	Code
(CBT) for CS750	CBC	Type HC Overlaid	HCO	Concrete-Arch	CA
(DBT) for CS750	DBC	GR Stringer	GR	Beam-and-Slab	CB
Composite Bulb-T	CBT	HC Stringer	HC	Others	CC
Decked Bulb-T	DBT	H Stringer	HH	Concrete-Frame	CF
Type-FC	FC	Type H Overlaid	HHO	Flat Slab	CS
Metric (LF)	FM	Old M Type	MM	Concrete-Tee	CT
Latest Fenrich	LF	A Stringer	PA	Voided-Slab	CV
Type - NU	NU				
Metric (PO)	OM	E Stringer	PE	Box	CX
Box Girder (Precast)	PB	E Short Stringer	PES	Box (Prestressed)	CXP
Others	PJ	G Stringer	PG		
Type-M	PM	Type G Overlaid	PGO		
Type-M Overlaid	PMO	Precast Slab	PS		
Type-O	PO	Special	PX		
Tee Girder	PQ	(HC) for HS25	VH		
Type-RD	RD	E Stringer (First)	PEF		
Metric (RD)	RM				
(SM) for CS750	SC				

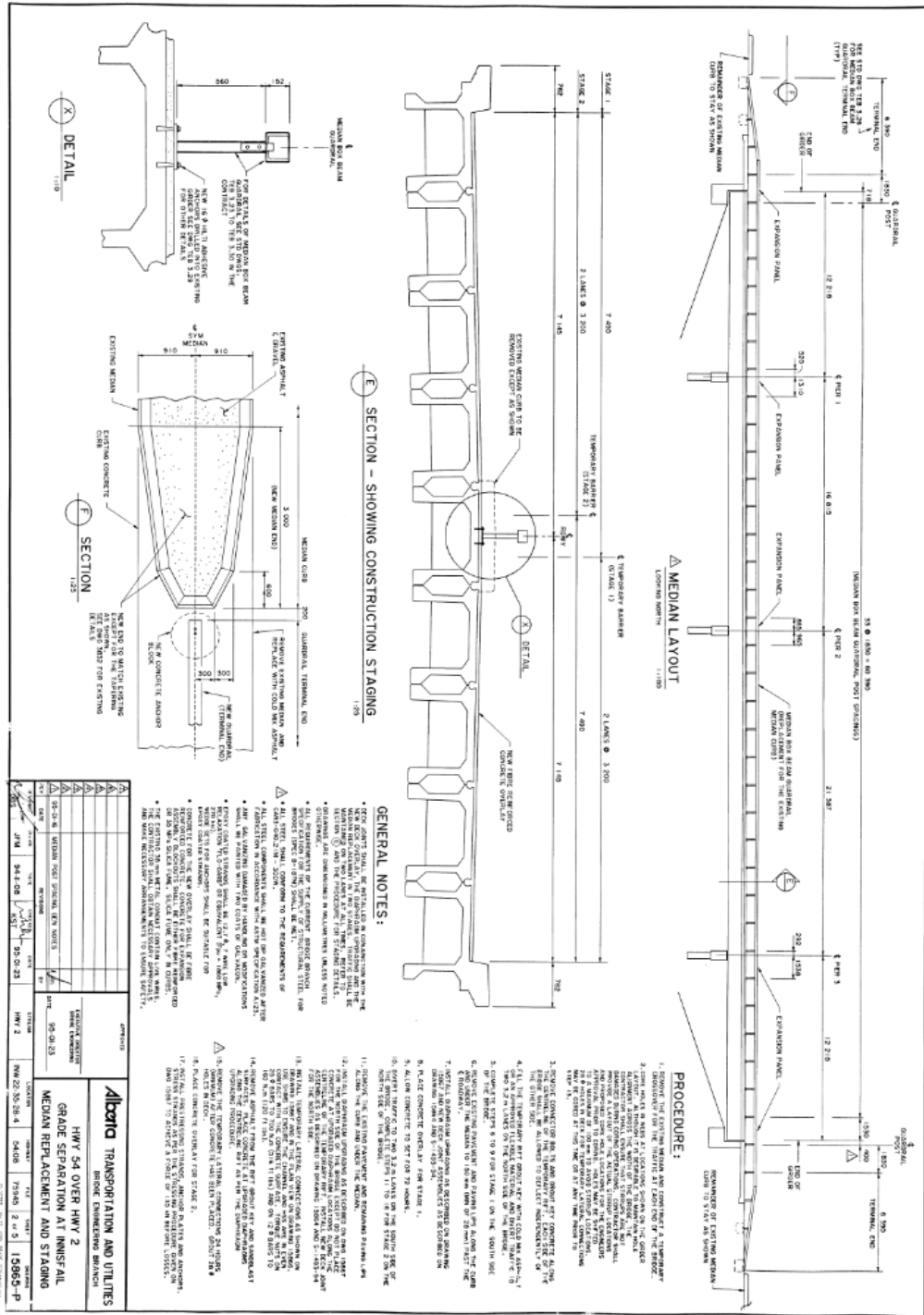

Sample of bridge as-built changes

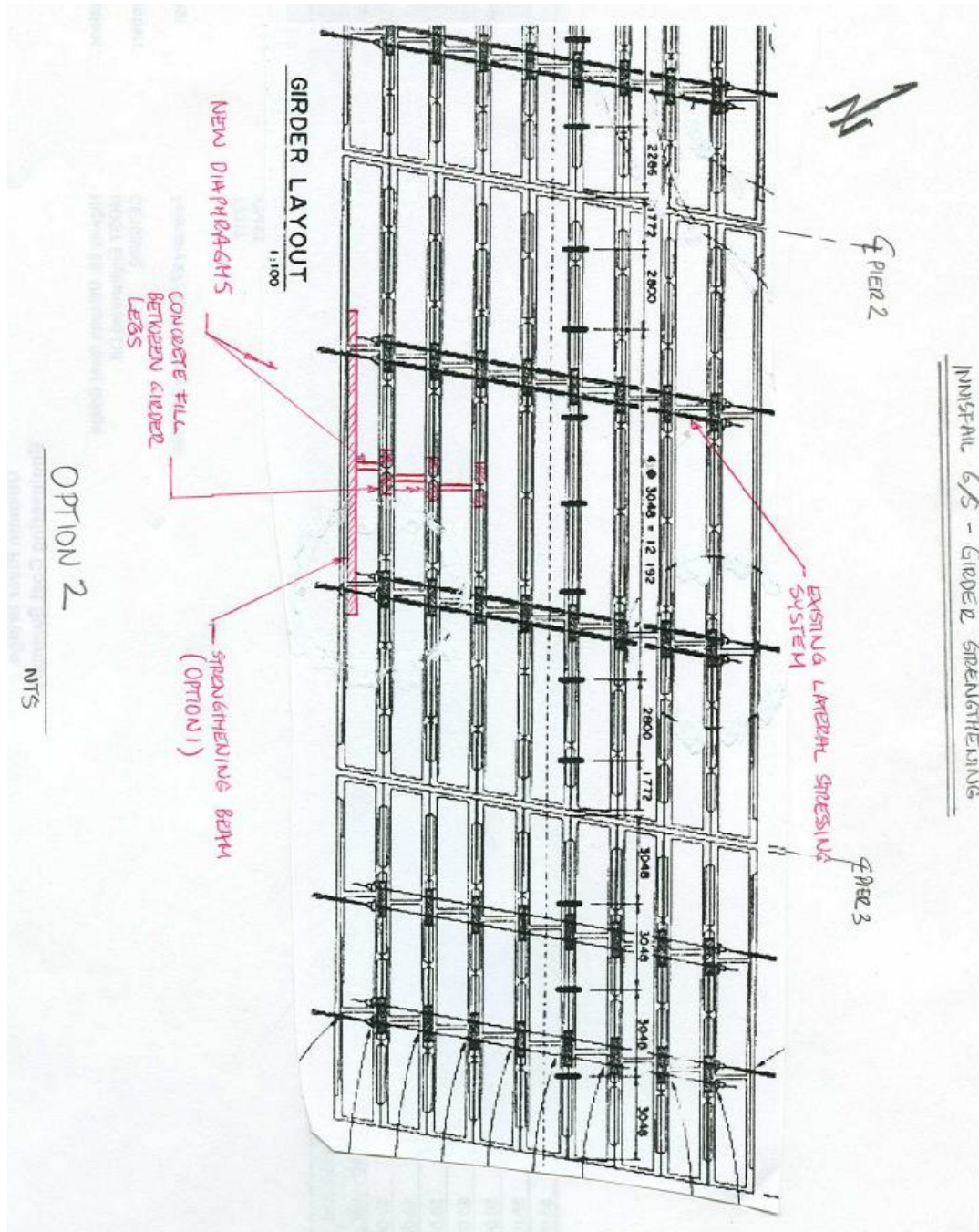

APPENDIX 4

TABLE OF CONCRETE BRIDGE DEFECTS AND THEIR POTENTIAL OCCURRENCE LOCATION

(Adapted from BIRM, 2012; BIM Reference Manual, 2007)

Defect Type	Description ₂	Orientation	Severity	Potential Location	Location in Cast-in-place Slabs	Location in Tee beams and Concrete girder bridges	Location in Concrete Rigid Frames	Box girder bridges
Cracking, flexure	Cracks which are caused by tensile forces	Transverse	REINFORCED CONCRETE(RC) PRESTRESSED CONCRETE(PC) HAIRLINE: RC< 1.6mm , PC< 0.1mm NARROW: RC< 1.6 to 3.2mm , PC< 0.1 to 0.23mm MEDIUM: RC< 3.2 to 4.8mm, PC< 0.25 to 0.76mm WIDE: RC≥4.8mm, PC≥ 0.76mm	Tension Zones	Midspan along the bottom of the slab, on top of the slab over the piers for continuous spans	Midspan along the bottom of the slab, on top of the slab over the piers for continuous spans, Diaphragms	bottom of the frame beam at mid-span, the base of each frame leg (usually buried), and the inside faces of the frame legs at mid-height of single span slab frames	The duct cracks are normally located on both sides of the longitudinal or neutral axis, top flange at pier locations and on the bottom flange at mid-span regions, Anchor blocks (termination of the post-tensioning tendons)
Cracking, shear	Cracks which are caused by diagonal tensile forces	Diagonal		Shear Zones, typically web of a member near the supports	Bearing Areas, Shear Zones (transverse cracks underside near supports, diagonal cracks on the sides of the slab)	Bearing Areas, Shear Zones (transverse cracks underside near supports, diagonal cracks on the sides of the slab), Diaphragms	Bearing Areas, Shear Zones (near the supports where the frame beams or slab meet the frame legs or abutments)	Bearing Areas, girder ends and sections close to piers, Deviation Blocks, Internal Diaphragms
Cracking, temperature	Cracks which are caused by the thermal expansion and contraction of the concrete	Transverse and longitudinal		Concrete Deck and all concrete components which has been prevented from contracting	Near supports when a bearing problem is detected			
Cracking, shrinkage	Cracks which are caused by shrinkage of concrete caused by the curing process in plastic shrinkage	All directions, short and irregular shapes		All concrete components after curing process				
Cracking, mass concrete	Cracks which are caused by thermal gradients in massive sections	All directions		Typically do not significantly affect the structural strength	Massive sections e.g. Concrete Deck and large girders			
Scaling	Gradual and continuing loss of surface mortar and aggregate		Light- loss of surface mortar up to 6 mm (¼ inch) deep, with surface exposure of coarse aggregates Medium scale- loss of surface mortar from 6 to 13 mm (¼ inch to ½ inch) deep, with mortar loss between the coarse aggregates	Concrete Deck, harsh environments which cause chemical breakdown of the cement bond	Concrete Deck, Areas exposed to traffic, Areas near bearings	Concrete Deck, Areas exposed to traffic, Areas near bearings	Concrete Deck, Areas exposed to traffic, Areas near bearings	

			<p>Heavy scale- loss of surface mortar from 13 to 25 mm (½ inch to 1 inch) deep; coarse aggregates are clearly exposed</p> <p>Severe scale- loss of coarse aggregate particles, reinforcing steel is usually exposed</p>					
Delamination	Separation of concrete layers at or near the level of the top or outermost layer of reinforcing steel due to expansion of corroding reinforcing steel	Typically longitudinal	Separation of delaminated area cause spall	Areas exposed to chlorides or salt Concrete Deck	Bearing Areas, Areas near wide cracks (Excessive tension stress)	Bearing Areas, Areas near wide cracks (Excessive tension stress), Concrete Deck	Bearing Areas, Areas near wide cracks (Excessive tension stress), Concrete Deck, Check the entire length of the frame legs for horizontal cracks, which indicate crushing	Bearing Areas, Deviation Blocks
Spalling	A depression in the concrete that is a separation and removal of a portion of the surface concrete	Roughly parallel to the surface	<p>Small spalls- not more than 25 mm (1 inch) deep or approximately 150mm (6 inches) in diameter</p> <p>Large spalls- more than 25 mm (1 inch) deep or greater than 150 mm (6inches) in diameter</p>	Delaminated areas -concrete surface Overstressed areas- at or near flexure cracks	Bearing Areas, Areas near wide cracks (in case of severe reinforcing steel corrosion)	Bearing Areas, Areas near wide cracks (in case of severe reinforcing steel corrosion), Concrete Deck	Bearing Areas, Areas near wide cracks (in case of severe reinforcing steel corrosion), Concrete Deck	Bearing Areas, Deviation Blocks
Chloride Contamination	Presence of recrystallized soluble salts	N.A		Areas exposed to chlorides or salt	Areas Exposed to Drainage (riding surface of the slab around scuppers or drains), Along the curbline and fascias	Areas Exposed to Drainage (riding surface of the slab around scuppers or drains), Ends of the stem	Areas Exposed to Drainage (riding surface of the slab around scuppers or drains), Ends of the stem	Areas Exposed to Drainage
Efflorescence	Increased flow within the concrete that is evidenced by dirty-white surface deposits, typically calcium carbonate leached out of the cement paste	N.A		Areas exposed to moisture	Areas near wide cracks, Areas Exposed to Drainage (riding surface of the slab around scuppers or drains)	Areas near wide cracks, Areas Exposed to Drainage (riding surface of the slab around scuppers or drains)	Areas near wide cracks, Areas Exposed to Drainage , bottom of the frame beam at mid-span, the base of each frame leg (usually buried), and the inside faces of the frame legs at mid-height of single span slab frames	Areas Exposed to Drainage
Wear	Wear is the gradual removal of surface mortar due to friction and occurs to	N.A		Areas exposed to friction e.g. Bridge deck	Areas exposed to friction e.g. Bridge deck	Areas exposed to friction e.g. Bridge deck	Areas exposed to friction e.g. Bridge deck	Areas exposed to friction e.g. Bridge deck

	concrete surfaces, like a bridge deck, when exposed to traffic							
Collision Damage	Strike and damage on concrete bridge components due to traffic strike	N.A		Areas exposed to traffic	Areas Exposed to Traffic	Areas Exposed to Traffic	Areas Exposed to Traffic	Areas Exposed to Traffic
Abrasion	Result of external forces acting on the surface of the concrete member	N.A		Areas exposed to silt-laden water or ice flow in rivers Concrete piers and pilings	Concrete piers and pilings	Concrete piers and pilings	Concrete piers and pilings	Concrete piers and pilings
Overload Damage	Serious structural cracking occurs when concrete members are sufficiently overstressed	Typically diagonal or transverse		Concrete decks, beams, and girders	Concrete decks, beams, and girders	Concrete decks, beams, and girders	Concrete decks, beams, and girders	Concrete decks, beams, and girders
Debonding of reinforcement in Prestressed Concrete	loss of bonding which reduces prestressforce	N.A		Areas near corroded tendons	Areas near wide cracks	Areas near wide cracks	Areas near wide cracks, , bottom of the frame beam at mid-span, the base of each frame leg (usually buried), and the inside faces of the frame legs at mid-height of single span slab frames	Areas near wide cracks