

# **A Network-Based System for Assessment and Management of Infrastructure Interdependency**

**Jiang Guo**

A Thesis

In

The Department

of

Building, Civil and Environmental Engineering

Presented in Partial Fulfillment of the Requirements  
for the Degree of Master of Applied Science (Civil Engineering) at  
Concordia University  
Montreal, Quebec, Canada

April 2010

© Jiang Guo, 2010



Library and Archives  
Canada

Published Heritage  
Branch

395 Wellington Street  
Ottawa ON K1A 0N4  
Canada

Bibliothèque et  
Archives Canada

Direction du  
Patrimoine de l'édition

395, rue Wellington  
Ottawa ON K1A 0N4  
Canada

*Your file* *Votre référence*  
ISBN: 978-0-494-70995-5  
*Our file* *Notre référence*  
ISBN: 978-0-494-70995-5

**NOTICE:**

The author has granted a non-exclusive license allowing Library and Archives Canada to reproduce, publish, archive, preserve, conserve, communicate to the public by telecommunication or on the Internet, loan, distribute and sell theses worldwide, for commercial or non-commercial purposes, in microform, paper, electronic and/or any other formats.

The author retains copyright ownership and moral rights in this thesis. Neither the thesis nor substantial extracts from it may be printed or otherwise reproduced without the author's permission.

**AVIS:**

L'auteur a accordé une licence non exclusive permettant à la Bibliothèque et Archives Canada de reproduire, publier, archiver, sauvegarder, conserver, transmettre au public par télécommunication ou par l'Internet, prêter, distribuer et vendre des thèses partout dans le monde, à des fins commerciales ou autres, sur support microforme, papier, électronique et/ou autres formats.

L'auteur conserve la propriété du droit d'auteur et des droits moraux qui protègent cette thèse. Ni la thèse ni des extraits substantiels de celle-ci ne doivent être imprimés ou autrement reproduits sans son autorisation.

---

In compliance with the Canadian Privacy Act some supporting forms may have been removed from this thesis.

While these forms may be included in the document page count, their removal does not represent any loss of content from the thesis.

Conformément à la loi canadienne sur la protection de la vie privée, quelques formulaires secondaires ont été enlevés de cette thèse.

Bien que ces formulaires aient inclus dans la pagination, il n'y aura aucun contenu manquant.

  
**Canada**

# **ABSTRACT**

## **A Network-Based System for Assessment and Management of Infrastructure Interdependency**

Jiang Guo

Critical infrastructures (CIs) provide services that are essential to both the economy and well-being of nations and their citizens. Over the years, CIs are becoming more complex and interconnected, they are all interdependent in various ways, including logically, functionally, and geographically. The interconnection between CIs results in a very complex and dynamic system which increases their vulnerability to failures. In fact, when an infrastructure is experiencing failures, it can rapidly generate a cascade or domino effect to impact the other infrastructures. Thus, identifying, understanding and modeling infrastructure interdependency is a new field of research that deals with interrelationships between critical infrastructure sectors for disaster management.

In the present research project, an integrated network-based analysis system with a user-friendly graphic user interface (GUI) was developed for risk analysis of complex critical infrastructure systems and their component interdependencies, called FCEPN (Fragility Curve and Extended Petri Net analysis). This approach combines: 1) Fragility Curve analysis of the vulnerability of the infrastructure, based on predefined “damage states” due to particular “hazards”; 2) Extended Petri Net analysis of the infrastructure system interdependency to determine the possible failure states and risk values. Two types of Extended Petri Net, Stochastic Petri Net and Fuzzy Petri Net were discussed in

this study respectively. The FCEPN system was evaluated using the Bluestone Dam in West Virginia and Huai River Watershed in China as the case studies. Evaluation study results suggested that the FCEPN system provides a useful approach for analyzing dam system design, potential and actual vulnerability of dam networks to flood related impact, performance and reliability of existing dam systems, and appropriate maintenance and inspection work.

## ACKNOWLEDGEMENT

I would like to express most sincere appreciation to my supervisor, Dr. Z. Chen, for his support, guidance, patience, and inspiration during my unforgettable days of learning and researching at Concordia. The completion of this thesis would be difficult without his continuous training and encouragement, which is often not limited to the academic aspect. It is a unique experience that I will treasure for years to come.

I greatly appreciate my committee professors: Dr. A. S. Ramamurthy, Dr. C. Wang and Dr. S. Li for their careful reviews and helpful comments.

I am also thankful to all my friends in our group for their valuable help in my research and study.

I would like to give my hearty gratitude to my father and mother for their love, concern, and blessings. My father-in-law and mother-in-law cannot be thanked enough for their constant love and support. I also really appreciate my sister for her support and encouragement. Finally, Special thanks are given to my wife, Hong Yan Miao. Without her love and support, I would never have completed this work. What she has done for me is far beyond words. It is also great pleasure to have my son Michael born during this unique period of time.

# TABLE OF CONTENTS

<b>LIST OF FIGURES .....</b>	<b>ix</b>
<b>LIST OF TABLES.....</b>	<b>xii</b>
<b>LIST OF SYMBOLS.....</b>	<b>xiii</b>
<b>CHAPTER 1 INTRODUCTION .....</b>	<b>1</b>
1.1 Overview.....	1
1.2 Research Objectives.....	4
1.3 Organization of the Thesis .....	4
<b>CHAPTER 2 LITERATURE REVIEW .....</b>	<b>6</b>
2.1 Infrastructures and their Interdependencies .....	6
2.1.1 Definition of critical infrastructures and interdependencies.....	6
2.1.2 Interdependencies and failures of critical infrastructures .....	8
2.1.3 Approaches and models for the analysis of infrastructures interdependencies..	9
2.2 Fragility Curve (FC) and Risk Analysis.....	12
2.3 The Basic Petri Net (PN) Modeling Approach and Extended Analysis.....	14
2.4 Summary .....	18
<b>CHAPTER 3 DEVELOPMENT OF A NETWORK-BASED SYSTEM: THE</b>	
<b>FCEPN SYSTEM.....</b>	<b>21</b>
3.1 Fragility Curve Analysis of a Water Infrastructure (Dam).....	22
3.1.1 Hydraulic and structural modeling of a primary water infrastructure (Dam)..	23
3.1.2 Steps of the probability calculations for developing the Fragility Curves.....	31
3.2 Extended Petri Net Method.....	32
3.2.1 Basic Petri Net .....	32

3.2.1.1 General properties of a basic Petri Net .....	32
3.2.1.2 Properties of Petri Nets (PNs).....	34
3.2.2 Extended Petri Nets (EPNs).....	36
3.2.2.1 Stochastic Petri Nets .....	36
3.2.2.2 Fuzzy Petri Nets.....	39
3.3 Markov Chain Analysis.....	46
3.4 Integrated Modeling and Analysis through the FCEPN System.....	48
<b>CHAPTER 4 DEVELOPMENT OF A USER-FRIENDLY GRAPHICAL USER</b>	
<b>INTERFACE (GUI) FOR THE FCEPN SYSTEM .....</b>	<b>51</b>
4.1 Introduction.....	51
4.2 GUI Design.....	54
4.2.1 System main interface.....	54
4.2.2 Dam SPN model interface .....	55
4.2.2.1 Input menu .....	56
4.2.2.2 Output menu.....	58
4.2.2.3 Simulation menu .....	59
4.2.3 Dam FPN model interface .....	60
4.2.3.1 Input menu .....	61
4.2.3.2 Output menu.....	64
4.3 Summary.....	65
<b>CHAPTER 5 CASE STUDY 1: BLUESTONE DAM CASE STUDY USED TO</b>	
<b>BUILD THE DAM BL MODEL BASED ON THE STOCHASTIC PETRI NET</b>	
<b>METHOD .....</b>	<b>67</b>

5.1 Definitions.....	67
5.2 Description of Interdependent Components in the Dam BL Model .....	68
5.3 Bluestone Dam and the Corresponding Dam BL Schematic Model .....	69
5.4 Development of Fragility Curves for Damage States of the Primary Infrastructure .....	70
5.5 Interdependency Analysis and Vulnerability Assessment for the Dam BL Model .	72
5.6 Validation of the Extended Petri Net Model Using Bayesian Network Method ....	83
5.7 Discussion .....	88
<b>CHAPTER 6 CASE STUDY 2: HUAI RIVER WATERSHED AS A MULTIPLE- DAM SYSTEM CASE STUDY BASED ON THE FUZZY PETRI NET METHOD</b>	<b>90</b>
6.1 Study Area.....	90
6.2 Steps of the Extended Petri Net Analysis and Risk Assessment.....	93
6.3 Extended Petri Net Model.....	94
6.4 Calculation of Relationship Strength .....	97
6.5 Results Analysis .....	102
6.6 Discussion .....	104
<b>CHAPTER 7 DISCUSSION.....</b>	<b>106</b>
<b>CHAPTER 8 CONCLUSIONS.....</b>	<b>110</b>
8.1 Summary of the Research .....	110
8.2 Contributions of the Research.....	111
8.3 Future Research .....	113
<b>REFERENCES.....</b>	<b>116</b>



## LIST OF FIGURES

Figure 3.1: Framework developed for the Fragility Curve analysis of a single primary infrastructure .....	23
Figure 3.2: Schematic of a dam (Linsley and Franzini, 1992).....	24
Figure 3.3: Uplift distribution when a crack extends beyond the drain line and drains are still effective (FERC, 1991).....	27
Figure 3.4: Uplift distribution with the crack not extending beyond the drains (FERC, 1991) .....	28
Figure 3.5: A graphical representation of a Petri Net (Sultana and Chen, 2007).....	36
Figure 3.6: Example of a SPN model (Jerath, 2002) .....	39
Figure 3.7: A Fuzzy Petri Net .....	41
Figure 3.8: An example of firing a marked Fuzzy Petri Net (a) before firing and (b) after firing (Chen et al., 1990).....	42
Figure 3.9: Representation of the type 1 rule in a Fuzzy Petri Net.....	44
Figure 3.10: Representation of the type 2 rule in a Fuzzy Petri Net.....	44
Figure 3.11: Representation of the type 3 rule in a Fuzzy Petri Net.....	45
Figure 3.12: Representation of the type 4 rule in a Fuzzy Petri Net.....	45
Figure 3.13: The flowchart of the development of the FCEPN system.....	48
Figure 4.1: Schematic diagram of the FCEPN system (The dotted lines show the GUI system developed to integrate the Fragility Curve and Extended Petri Net analyses) .....	52
Figure 4.2: The FCEPN system main interface .....	54
Figure 4.3: The Dam SPN model interface.....	55
Figure 4.4: Input menu of the GUI for the Dam SPN model.....	56

Figure 4.5: Input interface for Fragility Curve analysis in the Dam SPN model .....	57
Figure 4.6: Input interface for Stochastic Petri Net analysis in the Dam SPN model .....	58
Figure 4.7: Output menu of the GUI for the Dam SPN model .....	59
Figure 4.8: Simulation interface in the Dam SPN model .....	60
Figure 4.9: Dam FPN model interface.....	61
Figure 4.10: Input menu of the GUI for the Dam FPN model.....	62
Figure 4.11: Input interface for Fragility Curve analysis in the Dam FPN model .....	62
Figure 4.12: Input interface for Fuzzy Petri Net analysis in the Dam FPN model.....	63
Figure 4.13: Output menu of the GUI for the Dam FPN model .....	64
Figure 5.1: Dam BL model based on the Bluestone Dam (Ellingwood and Tekie, 2001), showing the various interacting infrastructure components of the system .....	68
Figure 5.2: Schematic diagram of the Bluestone Dam .....	72
Figure 5.3: Input interface for Fragility Curve analysis of the case study in the Dam SPN model.....	74
Figure 5.4: Fragility Curve analysis showing the probability of dam failure and four possible damage states (DS1-DS4) arbitrarily defined (Bluestone Dam data adapted from Ellingwood and Tekie (2001)) .....	75
Figure 5.5: Extended Petri Net model of the flood related infrastructure components based on the Dam BL model (Figure 5.1).....	76
Figure 5.6: Markov Chain analysis of failure probability based on the Extended Petri Net model shown in Figure 5.5, showing 24 different states s1-s24 .....	79
Figure 5.7: Input interface for the Stochastic Petri Net analysis in the Dam SPN model	79
Figure 5.8: Results for Extended Petri Net analysis in the Dam SPN model .....	80

Figure 5.9: Screen shot of the GUI simulation of the Dam BL model (integrated Fragility Curve with Extended Petri Net analysis) for different water levels .....	82
Figure 5.10: Screen shot of the results for water level of 53 m for the 12 different absorbing states (failure states) s13-s24 (see Figure 5.6) .....	82
Figure 5.11: Validation of the Markov Chain analysis results for the Extended Petri Net model using the Bayesian Network method .....	86
Figure 5.12: Bayesian Network analysis results confirming the 12 failure states identified with the Markov Chain analysis (Figure 5.6). (a): failure path 1-7; (b): failure path 8-1287	
Figure 6.1: The Huai River Watershed in China.....	91
Figure 6.2: Distribution of the rivers and lakes in the Huai River watershed .....	91
Figure 6.3: The Huai River watershed with digital elevation model (DEM) showing 17 dams/sluices .....	92
Figure 6.4: Framework for risk assessment of the Huai River watershed .....	94
Figure 6.5: Extended Petri Net model for the dams/sluices in the Huai River watershed	95
Figure 6.6: Input interface for the Huai River case study using the Dam FPN model ...	100
Figure 6.7: Analysis result for the Huai River case study using the Dam FPN model...	102

## LIST OF TABLES

Table 5.1: Thirteen places of the Extended Petri Net model (Figure 5.5) developed for the Dam BL model.....	77
Table 5.2: Nine transitions of the Extended Petri Net model (Figure 5.5) developed for the Dam BL model.....	78
Table 5.3: Probability of reaching the Markov Chain absorbing states (failure states) s13-s24.....	80
Table 5.4: Comparison of the probabilities for the Bayesian Network failure paths and the Extended Petri Net absorbing states (failure states) .....	88
Table 6.1: Seventeen places of the Extended Petri Net model developed for the Huai River watershed dams/sluices (shown in Figure 6.5) .....	96
Table 6.2: Sixteen transitions of the Extended Petri Net model developed for the Huai River watershed dams/sluices (shown in Figure 6.5) .....	97
Table 6.3: Reservoir capacities of the dams/sluices in the Huai River watershed.....	99
Table 6.4: Matrix showing the results of the relationship strength calculations for the 17 dams/sluices of the Huai River watershed (based on Equations 6.1, 6.2, 6.3) .....	101
Table 6.5: The results of the Probability risk calculations for the 17 dams/sluices in the Huai River watershed.....	102

## LIST OF SYMBOLS

$A$	Area of the contact plane ( $m^2$ )
$A_c$	Total area of the cross section ( $m^2$ )
$A_{c1}, A_{c2}$	Area of cross section of block 1, block 2, respectively ( $m^2$ )
$B$	Absorbing probability matrix
$b_1$	Top width of dam (m)
$b_2$	Width of the intersection line of block 1 and block 2 (m)
$b_3$	Base width of dam (m)
$b_{b1}, b_{b2}$	Width of the acting area of vertical hydrostatic pressure at upstream and downstream sides, respectively (m)
$C$	Unit cohesion ( $N/m^2$ )
$F_f$	Friction force along the contact plane (N/m)
$FS_{overturning}$	Factor of safety for overturning against the toe of dam
$FS_{sliding}$	Factor of safety against sliding along the contact plane
$FS_{shear-friction}$	Factor of safety against shear stress along the contact plane
$H_{b1}, H_{b2}$	Height of block 1 and block 2, respectively (m)
$H_d$	Height of dam (m)
$H_{h1}, H_{h2}$	Horizontal projection of hydrostatic pressure at upstream and downstream sides, respectively (N/m)
$H_{v1}, H_{v2}$	Vertical projection of hydrostatic pressure at upstream and downstream sides, respectively (N/m)
$H_{w1}, H_{w2}$	Upstream and downstream water levels, respectively (m)
$I$	Identity matrix

$L_{FR}$	Location of the resultant force along the dam base
$M_o$	Overturning moment (N-m/m)
$M_r$	Righting moment (N-m/m)
$N$	Fundamental matrix
$P_B^-$	Possibility of collapse of the dam/sluiice
$Q$	Transient matrix
$R$	Remaining matrix
$R_v$	Vertical projection of the reaction force at the base of the dam (N/m)
$(r)$	Capacity ratio of the dam/sluiice
$s_1$	Slope of the upstream of dam
$s_2$	Slope of the downstream of block 1
$s_3$	Slope of the downstream of block 2
$\tan \phi$	Coefficient of internal friction
$(u)$	Relationship strength of the dam/sluiice
$u$	Uplift pressure (N/m)
$u_{a1}, u_{a2}$	Rectangular and triangular part of the uplift pressure trapezoid, respectively (N/m)
$V_A, V_B$	Capacity of the dam/sluiice
$V_c$	Volume of concrete (m <sup>3</sup> )
$(w)$	Impact factor of the dam/sluiice
$W_c$	Weight of dam (N/m)
$x_{b1}, x_{b2}, x_c, x_u$	Distance of the center of gravity of block 1, block 2, dam concrete

	weight, acting of uplift pressure, respectively, from the toe of dam (m)
$\gamma_c$	Specific weight of dam (N/m <sup>3</sup> )
$\gamma_w$	Specific weight of water (N/m <sup>3</sup> )
$\mu$	Coefficient of the friction along contact plane
$\Sigma M$	Summation of moments about the upstream end of the joint (N- m/m)
$\Sigma V$	Summation of vertical forces including uplift pressures (N/m)

# CHAPTER 1 INTRODUCTION

## 1.1 Overview

The U.S. Patriot Act defines critical infrastructure as “systems and assets, whether physical or virtual, so vital to the U.S. that the incapacity or destruction of such systems and assets would have a debilitating impact on security, national economic security, national public health or safety, or any combination of those matters” (United States Congress, 2001). From this perspective, infrastructures include agriculture and food, water, public health and safety, emergency services, government, defense industrial base, information and telecommunications, transportation, postal and shipping, banking and finance, industry/manufacturing and energy (Office of Homeland Security, 2002). The infrastructures on which our society depends are interconnected and interdependent on multiple levels. Rinaldi et al. (2001) described infrastructure interdependency as a linkage or connection between two infrastructures, through which the state of one infrastructure influences or correlates to that of the other; interdependencies were termed as the “system of systems” or as several sets of interactions among the infrastructures.

When examining the more general case of multiple infrastructures connected as a “system of systems,” we must consider interdependencies. Infrastructure systems such as energy, telecommunications, water supply, wastewater treatment, and traffic are highly interdependent, either because they use each other as inputs or because they are physically located in close proximity to each other and can therefore affect each others’ performance. The failure of one infrastructure can result in the disruption of other infrastructures, which can cause severe economic disruption and loss of life or failure of



services which impede public health and well-being. For example, the major power blackout that occurred in various parts of the eastern USA on August 14, 2003, lasted up to 4 days, caused traffic's congestion and affected many other critical infrastructures, and the estimated direct costs were between \$4 billion and \$10 billion (US-Canada Power System Outage Task Force, 2004).

Critical societal infrastructures (e.g. telecom, energy, water supply, and wastewater) are often interdependent and interconnected physically and/or functionally. Structural vulnerability assessment methods have been developed over the past twenty years (e.g. Chock, 2005; Hall et al., 2003; Hwang et al., 2000) and the vulnerability of a structure or infrastructure to failure under various loading scenario is an important factor in its design, construction, monitoring, and maintenance. However, it is impossible to assess or analyze one infrastructure independently without relating it to the other surrounding components or infrastructures. Consequently, the study of the interdependencies among critical infrastructures components is important in order to address the cascade or domino effects of a single failed infrastructure on the entire system.

A vulnerability analysis is at the heart of the risk analysis methodologies for critical infrastructures, such as dams and bridges. Fragility Curve analysis, which conveys information about the vulnerability of an infrastructure through the probability distribution for various levels of a given hazard, is widely used in risk/vulnerability analysis in various industry sectors, such as seismic excitation for bridge piers in the USA and Japan (Hwang et al., 2001; Karim and Yamazaki, 2000), water systems (American Lifelines Alliance, 2001), electrical substations (Anagnos, 1999), seismically retrofitted

bridges and transportation networks (Shinozuka, 2001) and tall buildings (Tantala and Deodatis, 2002). However, it is challenging to develop the Fragility Curve, due to a lack of historical information on infrastructure components and the effect of natural disasters on them. Recently, network-based models have been employed to study the behavior of interconnected engineering infrastructure systems. For example, the network-based method, Petri Net modeling has been used to describe the interrelations and interdependencies among complex system components, such as software systems (Hura, 1987) and materials handling systems (Ramaswamy and Valavanis, 1994). Gursesli and Desrochers (2003) used a graph-based Petri Net to diagram interdependencies among the infrastructure components of a power plant. Petri Net has already been proven to be an efficient tool to model and simulate concurrent, discrete-event dynamic systems from above mentioned studies. As a graphical tool, Petri Net can be used as a visual-communication aid similar to flow charts. As a mathematical tool, it is possible to set up mathematic models governing the behavior of systems and derive system performance indices.

A new approach, called FCEPN (Fragility Curve and Extended Petri Net analysis), is developed in the present research study, which integrates Fragility Curve and Extended Petri Net analysis, together with a graphical user interface (GUI), for risk assessment and interdependency analysis of infrastructure systems and their components, to failure due to natural hazards. The FCEPN approach is then evaluated using a North America case study and a China case study.

## **1.2 Research Objectives**

The objectives of this study are as follows:

- 1) To develop a new network-based system (FCEPN; Fragility Curve and Extended Petri Net analysis) for modeling infrastructure interdependency and vulnerability assessment.
- 2) To analyze the overall performance of interconnected infrastructures through integrated analysis for emergency management.
- 3) To develop a user-friendly graphical user interface (GUI) system to facilitate the application of the FCEPN system.
- 4) To apply the FCEPN system and GUI to a North America case study and a China case study.

## **1.3 Organization of the Thesis**

This thesis is organized in the following seven chapters:

Chapter One presents a general introduction of the infrastructure interdependency issue and infrastructure interdependency related problems, as well as the objectives of the study.

Chapter Two presents a detailed literature survey of the previous related research work on infrastructure vulnerability and interdependency.

Chapter Three describes the theoretical background of the modeling tools and

development of the models, as well as the integrated system.

Chapter Four introduces the development of a user-friendly graphic user interface (GUI) for the integrated system.

Chapter Five evaluates the FCEPN network-based system integrated vulnerability assessment and network analysis using a case study of Bluestone Dam in USA.

Chapter Six applies the FCEPN network-based system to a second case study of Huai River watershed in China.

Chapter Seven presents a discussion of the network-based system.

Chapter Eight concludes with a brief summary, a list of contributions and suggestions for future research.

# CHAPTER 2 LITERATURE REVIEW

## 2.1 Infrastructures and their Interdependencies

### 2.1.1 Definition of critical infrastructures and interdependencies

The phrase “critical infrastructures” comes from the 1997 report *Critical Foundations -Protecting America's Infrastructures* (President's Commission on Critical Infrastructure Protection, 1997) by the President's Commission on Critical Infrastructure Protection (PCCIP), established by President Clinton following the 1993 bombing of the World Trade Center and the 1995 bombing of the Murrah Federal Building in Oklahoma City, OK. Critical Foundations and the subsequent Presidential Decision Directive 63, The Clinton Administration's Policy on Critical Infrastructure Protection (The White House, 1998), identified a set of critical infrastructure systems and their vulnerabilities, and established the need for and outlined a national strategy for action.

In Critical Foundations, the following definition is given for “Infrastructure”: a network of independent, mostly privately-owned, manmade systems and processes that function collaboratively and synergistically to produce and distribute a continuous flow of essential goods and services (President's Commission on Critical Infrastructure Protection, 1997).

Following the September 11, 2001 attacks, the USA Patriot Act (2001) revised the definition of critical infrastructure. The 2002 National Strategy for Homeland Security established the critical infrastructure sectors. The National Strategy also identified the key asset categories of: National Monuments and Icons; Nuclear Power Plants; Dams;

Government Facilities; and Commercial Key Assets.

Critical Foundations discussed the reliance or dependence of the critical systems and Rinaldi, Peerenboom and Kelly (2001) formalized the definitions within this ongoing discussion of critical infrastructure interdependencies:

**Dependency:** A linkage or connection between two infrastructures, through which the state of one infrastructure influences or is correlated to the state of the other.

**Interdependency:** A bi-directional relationship between two infrastructures through which the state of each influences or is correlated to the state of the other. More generally, two infrastructures are interdependent when each is dependent on the other.

Also, they defined four classes of interdependency:

- **Physical interdependency:** a physical interdependency arises from a physical linkage between the inputs and outputs of two agents: a commodity produced or modified by one infrastructure (an output) is required by another infrastructure for it to operate (an input).
- **Cyber Interdependency:** An infrastructure has a cyber interdependency if its state depends on information transmitted through the information infrastructure.
- **Geographic Interdependency:** Infrastructures are geographically interdependent if a local environmental event can create state changes in all of them. A geographic interdependency occurs when elements of multiple infrastructures are in close spatial proximity.

- **Logical Interdependency:** Two infrastructures are logically interdependent if the state of each depends on the state of the other via a mechanism that is not a physical, cyber, or geographic connection.

The objective of the definitions is to aid in the discussion of policies for addressing the vulnerability of infrastructures to natural, technological and intentional human-induced hazards.

### 2.1.2 Interdependencies and failures of critical infrastructures

Over their service life, physical infrastructures should resist different threats, including floods, earthquakes, wind, ice, other natural hazards, and malicious human attacks. A failure in one infrastructure can cause a cascade and cause disruption or failure in others, and the combined effect could prompt devastating consequences that will affect the government, public health, and national security (Hoyt, 2004). As discussed by Rinaldi et al. (2001), failures affecting the interdependencies of infrastructures can be described in the following categories:

- **Cascading failure:** occurs when a disruption in one infrastructure causes a failure in another infrastructure.
- **Escalating failure:** occurs when a disruption in one infrastructure aggravates an independent disruption of a second infrastructure.
- **Common cause failure:** the disturbance or interruption of the services provided by two or more infrastructures at the same time is caused by a common event, such as a natural disaster or other disaster.

The recognition of the importance of critical infrastructures for the economic and social well-being of a nation and its citizens has opened a wide area of study. Several aspects of this field of study have received significant attention, including the identification of risks and threats to critical infrastructures, and impact of disruptions to critical infrastructures on the economy of a region or a country. In addition, several studies have been conducted to analyze the interactions between critical infrastructures and how these interactions affect their performance. The following sections discuss the challenges in analyzing critical infrastructure and their interdependencies and approaches to analyze those interdependencies.

### **2.1.3 Approaches and models for the analysis of infrastructures interdependencies**

The modeling of cascading processes among infrastructure elements is a relatively new and very important field of study. Currently, there are several innovative modeling approaches.

Two popular approaches for analyzing the interdependent infrastructures are agent-based simulation and input-output analysis. The core idea behind the development of agent-based simulation for this application is that individual components and subsystems can be represented as agents which are designed to evolve and interact with each other, then interdependencies can be identified for them (Tomita et al., 1998; Wildberger, 1997; Wildberger, 1998; Amin, 2000). Agent-based simulation is also being used to investigate the electric power and natural gas markets (North, 2000a; Tsoukalas et



al., 1999). North (2000b) proposed an agent based model for infrastructure interdependency policy analysis. Similarly, Agent-based Infrastructure Modeling and Simulation (AIMS) (Pederson et al., 2006) is an agent-based system to simulate and model the interdependencies of Canadian critical infrastructures.

Input-output analysis has traditionally been used to model the interactions among sectors of the economy and to forecast the impact that the changes in one part of the economy may have on the performance of the others. Haines and Jiang (2001) presented a Leontief-based input-output model called the inoperability input-output model (IIM) which accounts for interconnectedness among infrastructure systems. However, this approach works at a macroscopic level and while useful for vulnerability assessment, it would be difficult to extend this approach to restoration activities. In a more recent study (Haines et al., 2005), they continue the development of the IIM and its ability to demonstrate how the Inoperability IIM can be applied to analyze attacks on electric power and telecommunications. Other authors (Jiang and Haines, 2004; Reed et al., 2006) have proposed a phenomenological approach based on the Leontief formalism which, given an interdependence matrix that groups the sensitivity of the operability of each critical infrastructure (CI) with respect to those of the others, allows them to evaluate the repercussions of the decrease of operability of one CI on the others. This analysis, however, relies on the availability of the above-mentioned interdependence matrix. The main goal of this study is to define a methodological workflow which, starting from the description of functional models of CI and their interdependency, allows the estimation of the sensitivity values that will fill the elements of that matrix.

There have been several other studies that involved the formulation of models for quantification of relationships between infrastructures. Newman et al. (2005) studied a system composed of two connected networks (L and M). They assumed that, in the presence of a failure in one component of the system (say L), e.g., an overload condition, this has the effect of producing a redistribution of the load on the components of system M, and increasing the load on the other components of L itself. The authors showed that this interdependent load increase induces a shift in the critical point or, in other terms, the coupling makes the system more susceptible to large failure. Dudenhoeffer et al. (2006) introduced a graphical representation of infrastructures in which nodes represent infrastructure components and edges represent the relations between nodes. A dependency matrix provides a potential formulation for quantitative representation of interdependencies between infrastructures and analysis of their impact. The Critical Infrastructure Protection Task Force of Canada used a dependency matrix to relate the interdependency among six sectors identified as crucial: Government, Energy and Utilities, Services, Transportation, Safety, and Communications (Dunn and Wigert 2004). Fiedrich (2006) presented a distributed simulation system for disaster response activities based on the High Level Architecture (HLA). Other modeling techniques also include Distributed Interactive Simulation (DIS), effects-based operations (EBO) models, models based on game theory, and models based on risk (Min et al., 2007). Gursesli and Desrochers (2003) propose Petri Net for modeling infrastructure interdependencies. However, their work models an entire infrastructure system (such as electric power or transportation) as a single node. While useful in showing relationships, it lacks sufficient details to be useful for either planning and mitigation or response and restoration

activities.

## 2.2 Fragility Curve (FC) and Risk Analysis

Fragility analysis is a standardized methodology, utilized for performance-based structural design. As a general statement, Fragility Curves (FCs) measure (or quantify) the overall structural vulnerability (Norton et al., 2008). Issues of infrastructure vulnerability are directly related to environmental or economical risks or losses. Vulnerability assessment using FC is widely practiced for risk analysis of infrastructure systems.

The definition of basic damage states, corresponding FCs and conditional probabilities for estimating damage matrices was discussed in detail by Filliben et al. (2002). Fragility Curves can be either empirical or analytical. Empirical Fragility Curves are based on past damage experience and usually describe the observed damage level under certain condition and help to calibrate analytically developed FCs. A number of studies have presented empirical FCs for bridges damaged in the Northridge, Loma Prieta, and Kobe earthquakes (Shinozuka et al., 2000; Shinozuka et al., 2003; Basoz et al., 1999; Yamazaki et al., 1999), based on the available data from inspection reports after earthquakes. Shinozuka et al (2003) presented both methods. The maximum likelihood method was used for generating the empirical FCs from the observation of bridges damage in the 1995 Northridge and 1996 Kobe earthquakes. Analytical FCs were constructed for typical bridges in Memphis, Tennessee, utilizing nonlinear dynamic analysis.

Simpson et al. (2005) proposed an interdisciplinary modeling framework based on the development of Fragility Curves for each single critical infrastructure in a community, for multi hazards, in order to maximize the allocation of the limited preparedness resources; it was discussed that FC-based vulnerability is a function of the age, redundancy, and construction types of the infrastructures. Until today, FCs have been mostly developed for the urban infrastructures, such as bridges, steel structures, buildings, storage tanks, etc. Fragility Curves have been greatly used to perform seismic risk analysis. Applied Technology Council was the first group to generate a systematic approach for quantifying structural fragility in a report directed to the Seismic Safety Commission of the state of California (ATC-13, 1985). The results were later tested and verified by the Committee on Earthquake Engineering (CoEE, 1989) using different panels of experts and similar terminology. Singhal and Kiremidjian (1996) present a systematic approach for developing FCs for reinforced concrete frames using Monte Carlo simulation. Later Singhal and Kiremidjian (1998) proposed a Bayesian statistical analysis method for combining damage data with analytical earthquake ground motion to enable periodic modification of FCs as damage data become available. Later Karim and Yamazaki (2003) developed a simplified method to construct FCs for highway bridges of Japan. They proposed a formulation to find FC parameters based on the height of the pier and the over-strength ratio of the structure. Hwang et al. (2000) presented a method for evaluating seismic damage to bridges and highway systems in earthquake-prone areas like Memphis and Shelby County, Tennessee, by developing FCs for different classes of bridges. Chock (2005) examined the fragilities and associated risks of a wide variety of buildings using a GIS supported hurricane damage database. Developing FCs, among

other measures, were considered for infrastructure risk assessment by Hall et al. (2003). Fragility Curves have been also used as a tool for assessment of the retrofitting option. Kim and Shinozuka (2004) developed FCs to study the nonlinear dynamic responses of two bridges retrofitted by steel jacketing of bridge columns.

In this literature review, vulnerability assessment of individual infrastructure with Fragility Curves development for different kinds of infrastructures (e.g. bridge, water, steel, concrete) have been reviewed. The FC development approach used in these studies is a very novel method in vulnerability assessment field, but the inherent problem is that developing FCs requires a huge historical database for validation, which is difficult to establish. Also, if the uncertain parameters are not incorporated correctly, it may result in a wrong assessment. If, however, Fragility Curves can be developed soundly, then these represent very straightforward and robust tools for vulnerability assessment of critical infrastructures.

## **2.3 The Basic Petri Net (PN) Modeling Approach and Extended Analysis**

Petri Net (PN) is a graphical and mathematical modeling approach that has been used to search for natural, simple and powerful methods for describing and analyzing the flow of information and control in systems. The PN approach has evolved as a suitable method for studying systems that are concurrent, asynchronous, distributed, parallel and/or stochastic. Petri Net was first introduced by Carl Adam Petri in 1962 in Germany (Petri, 1962). Improvements in PN analysis were subsequently made by other researchers

in this field (Peterson 1981, Manson 1988, Murata 1989, Bobbio 1990). Since the late 1970s, PN has become a common tool for describing, simulating and analyzing behaviors of concurrent, discrete, and distributed dynamic systems.

As a PN is represented by a set of algebraic equations or other mathematical models which reflect a system's behavior, it is suited for modeling and designing both hardware and software systems. In particular, PN has been successfully used for a wide range of applications to solve real world problems, such as operating systems and compilers, distributed databases, communication protocols, real-time fault-tolerant and safety-critical systems, manufacturing systems, sequence controller systems, communication networks, robotic systems, parallel computer architectures, speed-independent circuit design, and so on (Agerwala, 1979; Zurawski and Zhou, 1994). For example, one of the most successful application areas of Petri Net has been in modeling and analyses of communication protocols (Berthomieu and Diaz, 1991; Billington et al., 1988; Chehaibar, 1990; Florin et al., 1989; Huber and Pinci, 1991; Ramamoorthy, 1987). In the past few years, a number of approaches have been proposed which allow for the construction of PN models of protocols from specifications written in a relatively skill-free language (Lakos and Keen, 1991; Suzuki et al., 1990). Petri Net has been used extensively to model and analyze manufacturing systems. In this area, PNs were used to represent simple production lines with buffers, such as machine shops, automotive production systems, flexible manufacturing systems, automated assembly lines, resource-sharing systems, and recently just-in-time manufacturing systems (Adamou et al., 1993; Amar et al., 1992; Bastide and Silbertin-Blanc, 1991; Zhou, 1993; Zurawski and Dillon, 1991).

While Petri Net has been extensively used to determine the interdependencies among the infrastructures in a network, Gursesli and Desrochers (2003) used a graph based PN for identifying the interdependencies among critical urban infrastructures defined by Rinaldi et al. (2001). The network, consisting of the critical infrastructure (such as electric power, oil, transportation, natural gas, telecommunications, and water sectors), was analyzed to examine the interdependencies among these infrastructures due to the failure of the main supporting infrastructure, the power plant. The model execution starts with the occurrence of a hazard and the execution stops when all the interconnected infrastructures are disrupted. It was shown that the Petri Net was capable of representing the in-service or failed conditions of the infrastructures before and after the power disruption. Thus, PN is a very strong modeling tool to capture the interrelationships among the infrastructures. However, the model didn't consider the recovery strategies in the network.

Although the basic Petri Net approach is powerful for modeling tasks, data, states, events, conditions, synchronization, parallelism, choice, iteration and all of the control flow structures, it is limited for modeling real-world problem, such as complex and extremely large workflows (Aalst and Hee, 2002). Furthermore, basic PNs do not allow for modeling of data and time because they lack a temporal descriptor, and therefore fail to represent any timing constraints for time-dependent systems, which may be crucial to some workflow processes. To solve these problems, many extensions have been proposed to enhance the classical Petri Net model (Peterson, 1977). These extensions either add properties that cannot be modeled in basic PN or simply improve the representation of PN. Examples of extended PNs include: extension with color to model data using

Colored Petri Net; extension with hierarchy to structure large models; extension with time to deal with timing issues; and extension with fuzzy rules to represent uncertain knowledge.

The concept of time is not explicitly given in the original definition of Petri Net. However, for performance evaluation and scheduling problems of dynamic systems, it is necessary and useful to introduce time delays associated with transitions and/or places in PN models. These are termed Timed Petri Net (Ramchandani, 1974) if the delays are deterministically given, and Stochastic Petri Net (Balbo, 2001) if the delays are probabilistically specified. Cirado and Lindemann (1993) presented a time and space efficient algorithm for computing steady state solutions of deterministic and stochastic Petri-Net (DSPN) with both stochastic and structural analysis. Sultana and Chen (2007) predicted the safety assessment of floodplain infrastructures using the Extended Petri Net. A simple Generalized Stochastic Petri Net (GSPN) model having immediate and timed events was introduced for identifying common mode faults, for modeling the cascading failures of critical infrastructures (Krings and Oman 2003).

The basic Petri Net approach is insufficient to describe a system that has fuzzy behavior or vague values, such as “small” and “big”. In recent years, many Fuzzy Petri Net (FPN) models have been proposed to solve practical problems for different applications. Looney (1988) reviewed reasoning by means of transformations of the truth states by rule matrices and adopted FPN through the application of Boolean Matrices to simulate actual situations. This PN extension has been used to model fuzzy reasoning with propositional logic. In Chen et al. (1990), a FPN model was used to represent the



fuzzy production rules (each rule describes the fuzzy relationship between two propositions) of a rule-based system. Based on this FPN model, a fuzzy reasoning algorithm was developed that can be used to determine whether or not an antecedent-consequence relationship exists from one proposition (called starting place) to another proposition (called goal place). In Ashon (1995), a Fuzzy Neural Petri Net (FNPN) was proposed for representing a fuzzy knowledge base and for fuzzy reasoning. FPN techniques have also been widely used for modeling and analyzing sensor-based robotics systems (Cao and Sanderson, 1993), quantifying the interrelationships and cascading effects between the geospatial objects in disasters (Xing et al., 2009), as well as Horn and non-Horn clausal fuzzy reasoning systems (Chaudhury, 1993).

## **2.4 Summary**

This chapter reviewed the current published literature on the analysis of critical infrastructures. Current modeling approaches and techniques used for the analysis of critical infrastructures and their interdependencies were addressed, emphasizing the modeling platforms, infrastructures modeled and intended use. Vulnerability assessment of individual infrastructures with Fragility Curves (FCs) developed for different kinds of infrastructures (e.g. bridge, water infrastructure, steel structure, concrete structure, etc.) were described. This chapter also provided a discussion of network approaches and available network models such as basic Petri Net (PN), Extended Petri Net (EPN), and their application in different fields.

The literature review indicates that some shortcomings exist in the previous studies. These limitations include the following:

- 1) Vulnerability assessment using Fragility Curves is widely practiced for risk analysis of infrastructure systems. However, FCs have been mostly used to perform seismic risk analysis; they are rarely used to analyze water infrastructures, such as dams. In addition, the inherent problem is that developing FCs requires huge historical database for validation, which are often difficult to obtain. Also, if the uncertain parameters are not incorporated correctly, FCs may result in an incorrect assessment.
- 2) Extended Petri Nets based on the basic PN approach are powerful for modeling real-world problems dynamically. Only a few studies, however, used PN to determine the interdependencies among the infrastructures system, and these used PN for capturing infrastructure interdependency qualitatively but did not include any quantitative analysis.
- 3) Generally, vulnerability assessment of a single infrastructure is carried out for independent risk assessment. The literature reviewed showed that there is a lack of a comprehensive method which addresses infrastructure interdependency dynamically, as well as the vulnerability of an entire system/network of interconnected infrastructures. There is a clear need to develop novel methods for interdependent vulnerability assessment of networked infrastructure systems.

Therefore, in this thesis study, it is possible to extend previous studies to the following areas:

- 1) This study can analyze the vulnerability of an important water infrastructure (dam) using Fragility Curve analysis.

- 2) This study can also use Extended Petri Net to address the interdependency of a water infrastructure system. Both the qualitative interdependencies and the quantitative interdependencies will be captured.
- 3) An innovative network-based method/system (FCEPN) can be developed which integrates Fragility Curve analysis with Extended Petri Net analysis. This innovative method/system can be applied to real case studies to address the infrastructure interdependency dynamically and to assess the vulnerability of the infrastructure system comprehensively.
- 4) A user-friendly graphic user interface (GUI) can be developed and used with the novel network-based method/system (FCEPN), to facilitate its application and use as a decision tool.

# CHAPTER 3 DEVELOPMENT OF A NETWORK- BASED SYSTEM: THE FCEPN SYSTEM

In order to analyze the interdependencies of critical infrastructures in terms of failure, we designed a novel infrastructure interdependency analysis network-based system called FCEPN (Fragility Curve and Extended Petri Net analysis). Two methods were integrated within FCEPN: 1) Fragility Curve analysis of the primary infrastructure; 2) Extended Petri Net analysis of the interdependencies of the system components or multiple interdependent infrastructures. The FCEPN system can be used to analyze any infrastructure system. In this thesis, dams were selected as typical water infrastructures in case studies in order to evaluate the FCEPN system and to address the interdependency and risk assessment comprehensively.

In this chapter, before describing the FCEPN system, some related theories will be discussed briefly in order to understand the applicability of the FCEPN system and to understand the modeling steps used in its development. The detailed steps for Fragility Curve analysis for the primary infrastructure (e.g. dam) will be presented in section 3.1. In section 3.2, the basic Petri Net and its extensions will be discussed. In this study, two types of extensions of basic Petri Net, Stochastic Petri Net and Fuzzy Petri Net, will be introduced. In addition, in order to perform the extend analysis of the Extended Petri Net model that is developed in this study, a Markov Chain analysis was also conducted to simulate the risk of the infrastructure system.

### 3.1 Fragility Curve Analysis of a Water Infrastructure (Dam)

Fragility Curve analysis is a standard method for expressing the conditional probability of reaching or exceeding a limited damage state of a structure (or infrastructure) at the time of a given hazard (Sultana and Chen, 2007). The Fragility Curves convey the information about the vulnerability of an infrastructure through the probability distribution for various levels of hazard. Both empirical and analytical Fragility Curves analyses can be used simultaneously, however, the necessary large damage database is often not available. In this case, the usual way of determining the vulnerability of an infrastructure is by analytical Fragility Curves development. We used the general framework shown in Figure 3.1 for Fragility Curve development for the primary infrastructure. The detailed hydraulic and structural model (Figure 3.2) described by Linsley and Franzini (1992) was used for the analytical Fragility Curves analysis that was used for the dam in the case study. In this study, we consider flood water level as a hazard for the study of the failure of a hydraulic dam. The steps used in the development of the analytical Fragility Curve are summarized as follows:

1. Modeling of the infrastructure failure modes for a certain flood water level using the Monte Carlo simulation;
2. Classifying the damage states;
3. Determining the probabilities of exceeding the damage states;
4. Repeating the steps for different water levels;
5. Developing Fragility Curves based on the probabilities of damage states.

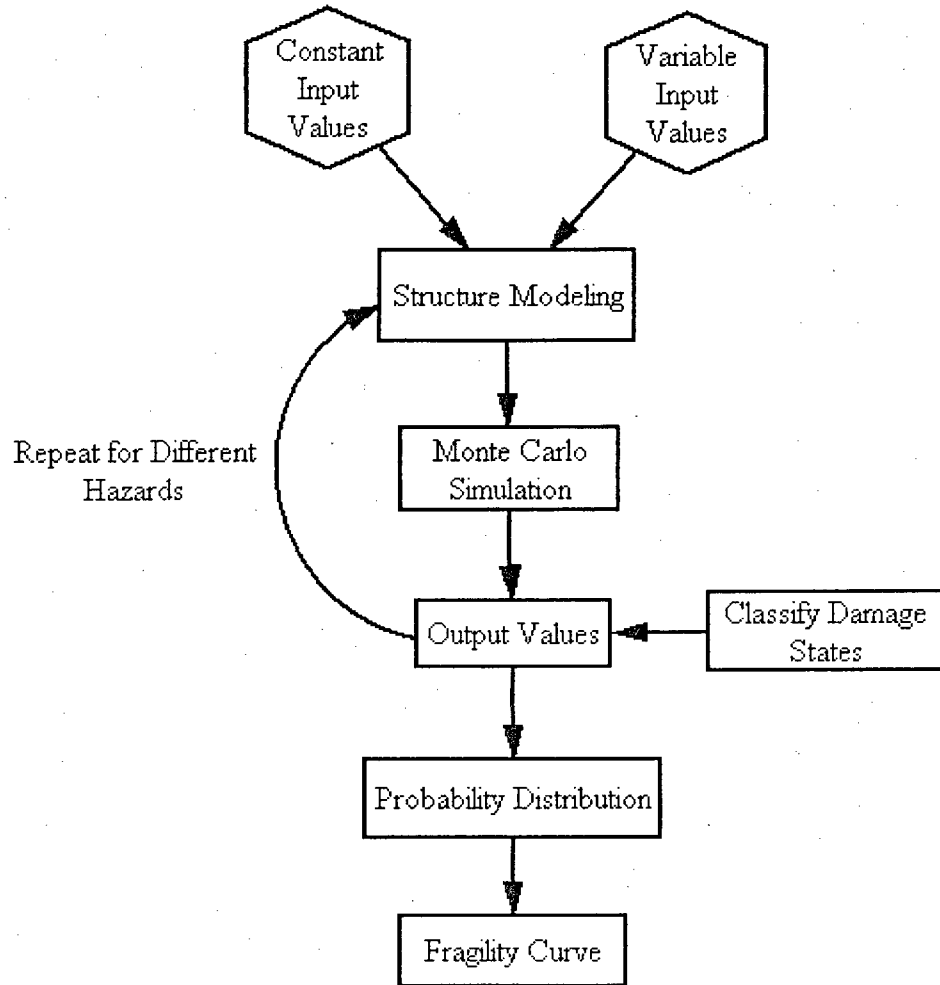

Figure 3.1: Framework developed for the Fragility Curve analysis of a single primary infrastructure

### 3.1.1 Hydraulic and structural modeling of a primary water infrastructure (Dam)

In this study, detailed hydraulic and structural modeling (Figure 3.2) is performed for the analytical Fragility Curves development. The details of the model are discussed briefly.

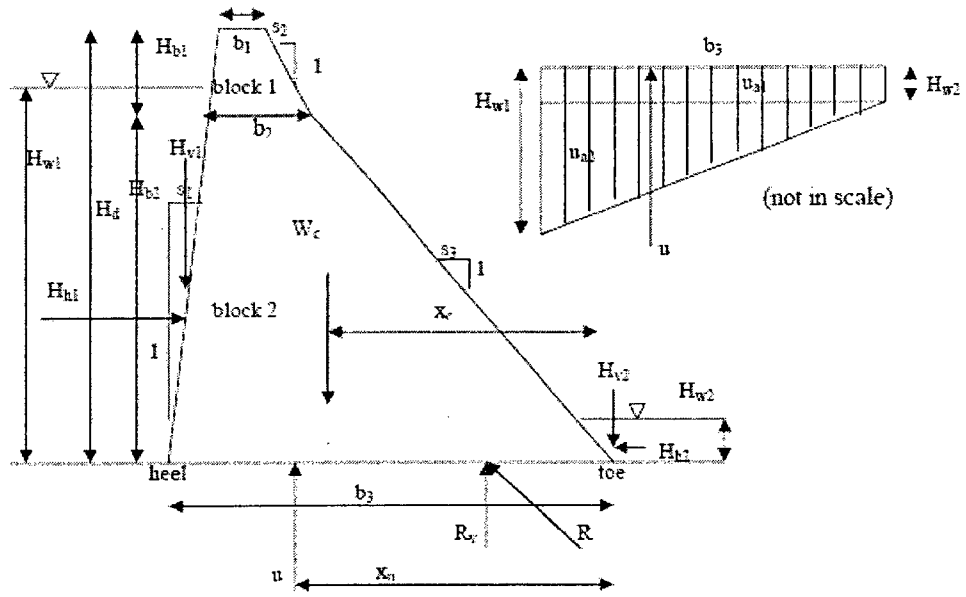

Figure 3.2: Schematic of a dam (Linsley and Franzini, 1992)

A. Concrete weight of the dam is calculated by Equations (3.1) ~ (3.9).

$$H_d = H_{b1} + H_{b2} \quad (3.1)$$

where,  $H_{b1}$ ,  $H_{b2}$  = height of block 1 and block 2, respectively (m);

$H_d$  = height of dam (m).

$$b_2 = H_{b1}s_1 + b_1 + H_{b1}s_2 \quad (3.2)$$

$$b_3 = H_{b2}s_1 + b_2 + H_{b2}s_3 \quad (3.3)$$

where,  $b_1$  = top width of dam (m);

$b_2$  = width of the intersection line of block 1 and block 2 (m);

$b_3$  = base width of dam (m);

$s_1$  = slope of the upstream of dam;

$s_2$  = slope of the downstream of block 1;

$s_3$  = slope of the downstream of block 2.

$$A_{c1} = H_{b1} \frac{(b_1 + b_2)}{2} \quad (3.4)$$

$$A_{c2} = H_{b2} \frac{(b_2 + b_3)}{2} \quad (3.5)$$

$$A_c = A_{c1} + A_{c2} \quad (3.6)$$

where,  $A_{c1}$  = area of cross section of block 1 ( $m^2$ );

$A_{c2}$  = area of cross section of block 2 ( $m^2$ );

$A_c$  = total area of the cross section ( $m^2$ ).

$$W_c = \gamma_c V_c \quad (3.7)$$

$$V_c = A_c \times \text{thickness} \quad (3.8)$$

For unit thickness,  $V_c = A_c$

$$\text{So, } W_c = \gamma_c A_c \quad (3.9)$$



where,  $V_c$  = volume of concrete ( $m^3$ );

$W_c$  = weight of dam (N/m);

$\gamma_c$  = specific weight of dam(N/  $m^3$ ).

B. Acting pressures on the dam is expressed by Equations (3.10) ~ (3.18).

$$b_{b1} = H_{w1} s_1 \quad (3.10)$$

$$b_{b2} = H_{w2} s_3 \quad (3.11)$$

where,  $b_{b1}$ ,  $b_{b2}$  = width of the acting area of vertical hydrostatic pressure at upstream and downstream sides, respectively (m);

$H_{w1}$ ,  $H_{w2}$  = upstream and downstream water levels, respectively (m).

$$H_{h1} = 0.5\gamma_w H_{w1}^2 \quad (3.12)$$

$$H_{h2} = 0.5\gamma_w H_{w2}^2 \quad (3.13)$$

$$H_{v1} = 0.5\gamma_w H_{w1} b_{b1} \quad (3.14)$$

$$H_{v2} = 0.5\gamma_w H_{w2} b_{b2} \quad (3.15)$$

where,  $H_{h1}$ ,  $H_{h2}$  = Horizontal projection of hydrostatic pressure at upstream and downstream sides, respectively (N/m);

$H_{v1}$ ,  $H_{v2}$  = vertical projection of hydrostatic pressure at upstream and downstream

sides, respectively (N/m);

$\gamma_w$  = specific weight of water (N/ m<sup>3</sup>).

The uplift pressure will be considered as acting over 100 percent of the base. A drainage gallery is located near the upstream face to collect seepage and reduce uplift across the base. The uplift pressure distribution along the base is dependent on the effectiveness of drain.

i) With drain. The uplift pressure at the base or below the foundation can be reduced by the effectiveness of the drain, the Federal Energy Regulatory Commission (FERC 1991) uplift distributions are shown below in detail (Figure 3.3 and Figure 3.4):

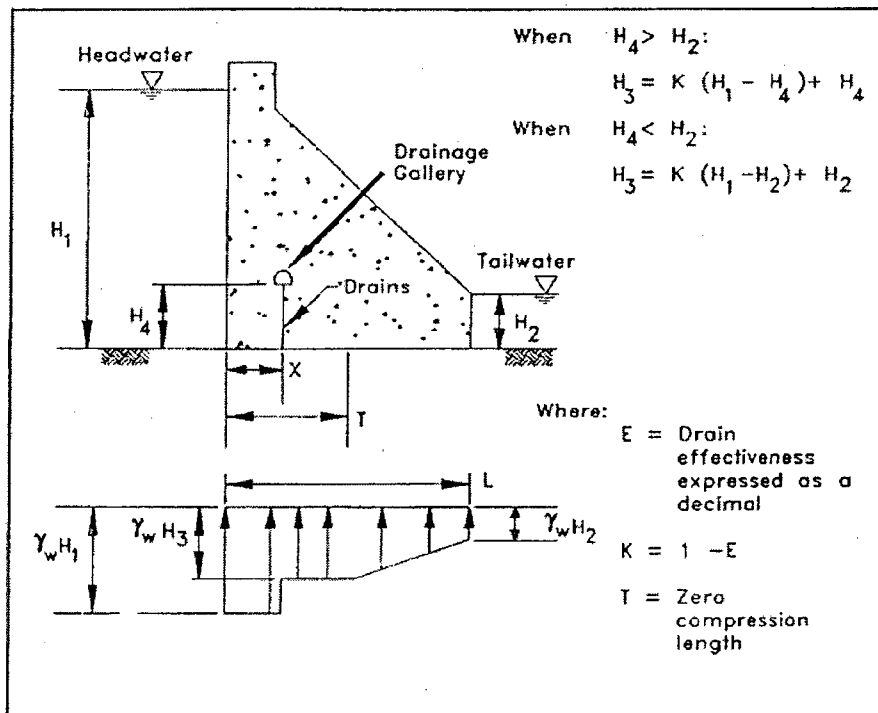

Figure 3.3: Uplift distribution when a crack extends beyond the drain line and drains are still effective (FERC, 1991)

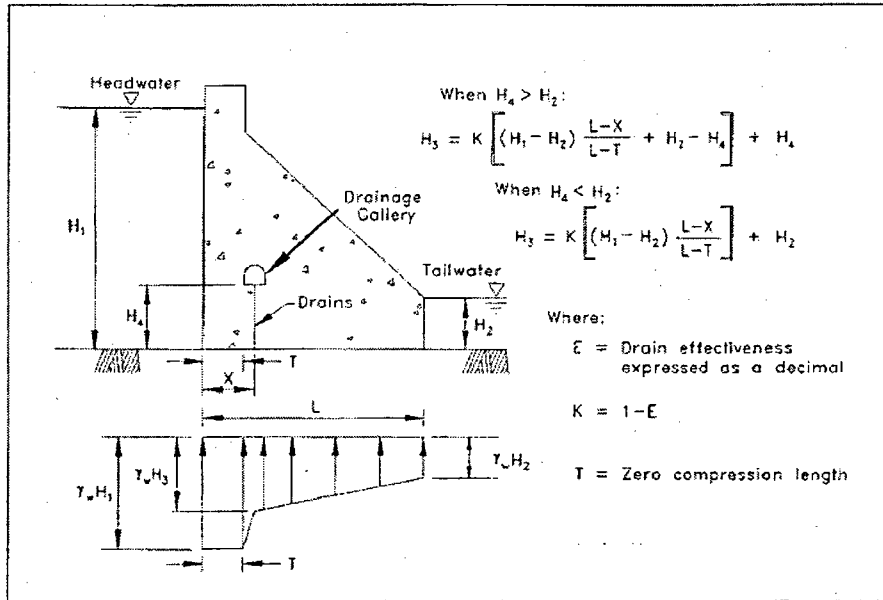

Figure 3.4: Uplift distribution with the crack not extending beyond the drains (FERC, 1991)

ii) Without drain. There have not been any provisions provided for uplift reduction, the hydraulic gradient will be assumed to vary as a straight line (in Figure 3.2).

$$u = \gamma_w \frac{H_{w1} + H_{w2}}{2} b_3 \quad (3.16)$$

$$u_{a1} = H_{w2} b_3 \quad (3.17)$$

$$u_{a2} = 0.5(H_{w1} - H_{w2}) b_3 \quad (3.18)$$

where,  $u$  = uplift pressure (N/m);

$u_{a1}$ ,  $u_{a2}$  = rectangular and triangular part of the uplift pressure trapezoid, respectively, (N/m);

C. Distance of center of gravity from the toe of dam is given by Equations (3.19) ~ (3.22).

$$x_{b1} = H_{b2}s_3 + \frac{2b_1b_2 - b_2H_{b1}s_1 - 2H_{b1}b_1s_1 - b_1^2 + 2b_2^2}{3(b_1 + b_2)} \quad (3.19)$$

$$x_{b2} = \frac{2b_2b_3 - b_3H_{b2}s_1 - 2H_{b2}b_2s_1 - b_2^2 + 2b_3^2}{3(b_2 + b_3)} \quad (3.20)$$

$$x_c = \frac{A_{c1}x_{b1} + A_{c2}x_{b2}}{A_c} \quad (3.21)$$

$$x_u = \frac{0.5u_{a1}b_3 + \frac{2}{3}u_{a2}b_3}{u_{a1} + u_{a2}} \quad (3.22)$$

where,  $x_{b1}$ ,  $x_{b2}$ ,  $x_c$ ,  $x_u$  = distance of the center of gravity of block 1, block 2, dam concrete weight, acting of uplift pressure, respectively, from the toe of dam (m);

D. Factor of safety (overturning) is calculated by Equations (3.23) ~ (3.25).

$$M_o = H_{h1} \frac{H_{w1}}{3} + ux_u \quad (3.23)$$

$$M_r = W_c x_c + H_{v1} \left( b_3 - \frac{b_{b1}}{3} \right) + \frac{1}{3} H_{h2} H_{w2} + H_{v2} \frac{b_{b2}}{3} \quad (3.24)$$

$$FS_{\text{overturning}} = \frac{M_r}{M_o} \quad (3.25)$$

where,  $M_o$  = overturning moment (N-m/m);

$M_r$  = righting moment (N-m/m);

$FS_{overturning}$  = factor of safety for overturning against the toe of dam.

E. Factor of safety (sliding) is calculated by Equations (3.26) ~ (3.28).

It is assumed that there is no bond between the blocks or between the material of the dam and the foundation material. Then, the shear failure can be represented as follows,

$$R_v = W_c + H_{v1} + H_{v2} - u \quad (3.26)$$

$$F_f = \mu R_v \quad (3.27)$$

$$FS_{sliding} = \frac{F_f}{H_{h1} - H_{h2}} \quad (3.28)$$

where,  $R_v$  = Vertical projection of the reaction force at the base of the dam (N/m);

$F_f$  = friction force along the contact plane (N/m);

$\mu$  = coefficient of friction along the contact plane;

$FS_{sliding}$  = factor of safety against sliding along the contact plane.

F. Factor of safety (shear-friction) is calculated by Equation (3.29).

If there is a bond between the blocks or between the material of the dam and the foundation material, the shear-friction failure can be represented as follows,

$$FS_{shear-friction} = \frac{CA + R_v \tan \phi}{H_{h1} - H_{h2}} \quad (3.29)$$

where,  $C$  = unit cohesion ( $\text{N/ m}^2$ );

$A$  = area of the contact plane ( $\text{m}^2$ );

$\tan \phi$  = coefficient of internal friction;

$FS_{shear-friction}$  = factor of safety against shear stress along the contact plane.

### 3.1.2 Steps of the probability calculations for developing the Fragility Curves

- 1) Inputs of the model:  $b_1, s_1, s_2, s_3, H_{b1}, H_{b2}, H_{w1}, \gamma_w, \gamma_c$ ;
- 2) Assigning random values of the uncertain parameters using a Monte Carlo simulation;
- 3) All the inputs are constant for the whole model simulation, except  $H_{w1}$  is variable for each simulation. Also, the random values are different for each simulation of the model;
- 4) In each simulation of the model, for the input values of  $H_{w1}$ , the model calculates the output values based on the criteria classification of damage states for each random numbers;
- 5) Then, the mean and standard deviation values of these calculated output values mentioned above are determined;
- 6) With the mean and standard deviation, the probability distribution is generated

with the assumption that the output values are normally distributed;

- 7) Thus, the model is run for enough number of inputs to get the probabilities for drawing the Fragility Curves.

In this section, the detailed steps for Fragility Curve analysis for the dam are presented by performing the hydraulic and structural dam modeling. In the next section, the other module of the FCEPN model, Extended Petri Net including SPN and FPN, will be discussed to introduce the related theories and applications.

## **3.2 Extended Petri Net Method**

### **3.2.1 Basic Petri Net**

#### **3.2.1.1 General properties of a basic Petri Net**

Petri Net analysis has been applied to study the behavior of concurrent, asynchronous, distributed, parallel, non deterministic, and/or stochastic systems (Murata 1989). Peterson, J. L. (1977) defines Petri Net as a 4-tuple (P, T, I, O). Here, P represents the set of places, T represents the set of transitions, I is the input function, and O is the output function. The input and output functions are defined for every transition in the set T. The input function for a transition defines the set of input places to that transition. Likewise, the output function for a transition represents the set of output places from that transition. If a place has an arc that is incoming from a transition, it is an input place. Alternatively, if a place has an arc outgoing to a transition, then it is an output place. A place may contain tokens that signify the resource availability, and it is generally represented by a circle or an ellipse. A transition, in turn, is connected only to places and

is generally represented by a box or a solid bar. A directed arc allows connections between transitions and places i.e. a connection from a transition to a place, or one from a place to a transition. Tokens flow throughout the network during the execution of the network. Assigning the tokens in places is called “marking” the network. A Petri Net has an initial distribution of the tokens which is called its initial marking. Figure 3.5 show a 4-tuple basic Petri Net.

The definition of Petri Net has evolved over time in different ways to respond with the prevailing research demands. When a concept was added to the Petri Net, the number of tuples was increased to describe the Petri Net appropriately.

Formally, A Petri Net (PN) can be described as an eight-tuple as follows:

$$PN = (P, T, I, O, A, W, M_0, B),$$

where  $P = \{p_1, p_2, \dots, p_m\}$  is a finite set of places

$T = \{t_1, t_2, \dots, t_n\}$  is a finite set of transitions such that ( $P \cup T \neq \emptyset$  and  $P \cap T = \emptyset$ ),

$I \subseteq P \times T$  is a finite set of input arcs from places to transitions,

$O \subseteq T \times P$  is a finite set of output arcs from transitions to places,

$A \subseteq \{T \times P\} \cup \{P \times T\}$  is a finite set of directed arcs,

$W : A \rightarrow N$  is a weight function where  $N$  is a set of non-negative integers,



$M_0 : P \rightarrow N$  is the initial marking where  $N$  is a set of non-negative integers,

$B \subseteq P \times T$  is a finite set of inhibitor arcs.

### 3.2.1.2 Properties of Petri Nets (PNs)

Enabling Rule: A transition  $t$  is said to be enabled if and only if: (i) Each input place  $p$  connected to  $t$  contains tokens whose number is greater than or equal to the weight of the directed arc connecting  $p$  to  $t$ , and (ii) each inhibitor place  $p$  connected to  $t$  contains tokens whose number is less than the weight of the directed arc connecting  $p$  to  $t$ .

Firing Rule: A firing of a transition  $t$ , that is enabled, removes from each input place  $p$  (connected to  $t$ ) the number of tokens equal to the weight of the directed arc connecting  $p$  to  $t$ . The transition  $t$  also adds to each output place  $p$  the number of tokens equal to the weight of the arc connecting  $t$  to  $p$ .

Reachability: Every firing of an enabled transition results in a change of the token distribution for the places in a Petri Net in accordance with the enabling and firing rule. A marking  $M_i$  is said to be reachable from a marking  $M_0$  if there exists a sequence of transition firings that results in a transformation of  $M_0$  to  $M_i$ .

Safeness: A place in a Petri Net is safe if the number of token never exceeds 1 in that place throughout the simulation; and a Petri Net is safe if all its places are safe.

Liveness: The property of liveness is associated closely with that of deadlock. A Petri Net is said to be live if it is possible to fire some transitions in the net by progressing through some further firing sequences. This implies that no firing sequence

should result in a deadlock for a live Petri Net.

For example, if:

$$PN = (P, T, I, O, A, W, M_0, B);$$

$$P = \{p_1, p_2, p_3, p_4\}; \quad T = \{t_1, t_2, t_3\};$$

$$I(t_1) = \{p_1\}; \quad O(t_1) = \{p_2, p_3\}; \quad I(t_2) = \{p_2, p_3, p_4\}, \quad O(t_2) = \{p_4\}; \quad I(t_3) = \{p_3\}; \quad O(t_3) = \{p_2\}; \quad B = \{p_3, t_2\};$$

The initial marking of the Petri Net is [1, 2, 0, 1], then a Petri Net is constructed as shown in Figure 3.5. In this Petri Net, the arc from  $p_2$  to  $t_2$  has the multiplicity of three which means, at least three tokens should be available in  $p_2$  and the other input places of  $t_2$  should also have enough tokens to enable  $t_2$  to fire. In this network,  $p_3$  is the inhibitory place for  $t_2$ ; so, if there is a token in  $p_3$ ,  $t_2$  cannot fire.

In this Petri Net, only transition  $t_1$  is enabled initially; when it fires, the output places  $p_2$  and  $p_3$  gain tokens. In this condition, as  $p_3$  is the inhibitory place for  $t_2$ ,  $p_3$  will be the input of  $t_3$ , and  $t_2$  now fires as there is no token in the inhibitory place of  $t_2$  and there are enough tokens in the input places of  $t_2$ ,  $t_3$  will also fire to give one token to  $p_2$ .

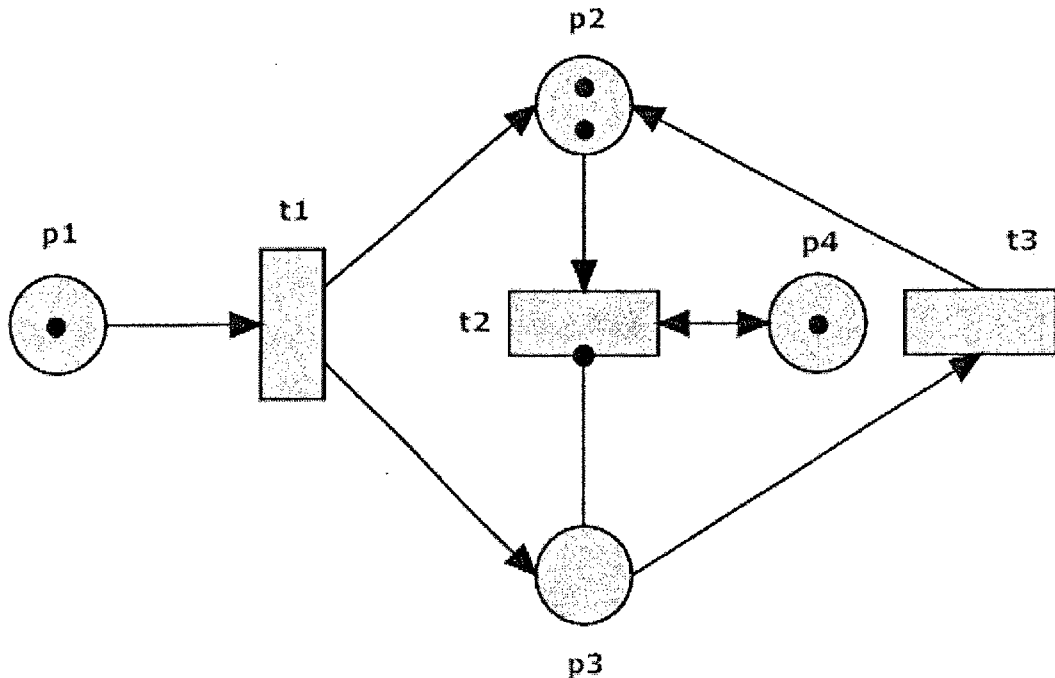

Figure 3.5: A graphical representation of a Petri Net (Sultana and Chen, 2007)

### 3.2.2 Extended Petri Nets (EPNs)

Since the Petri Net approach was invented in the early 60's, Petri Net theory has increased with the addition of new ideas, which means that a Petri Net can be enhanced with different types of extensions, in order to model complex systems where entities carry additional information. Many extensions of the basic PN formalism exist that try to incorporate time and other additional information into the network. These are called Extended Petri Net (EPN), and have additional information attached to the tokens in the network, such as Timed Petri Net, Stochastic Petri Net, Fuzzy Petri Net, etc.

#### 3.2.2.1 Stochastic Petri Nets

The concept of time is not explicitly given in the original definition of a Petri Net.

It is necessary and useful to introduce time delays associated with transitions and/or places in their models. Such a Petri Net model is known as a Timed Petri Net (Kchandani, 1974). This delay specifies the time that the transition has to be enabled, before it can actually fire. If the delay follows a random distribution function, the resulting net class is called a Stochastic Petri Net. Different types of transitions can be distinguished depending on their associated delay. These include immediate transitions (no delay), exponential transitions (delay is an exponential distribution), and deterministic transitions (delay is fixed).

The Stochastic Petri Net (Bause and Kritzinger, 1996)  $SPN = (PN, \Lambda)$  is formed from  $PN$  by adding the set  $\Lambda = (\lambda_1, \lambda_2, \dots, \lambda_n)$  to the definition, where  $\lambda_i$  represents the firing rate of transition  $t_i$ , and the firing time of  $t_i$  (denoted as  $X_i$ ) is exponentially distributed with probability distribution function given by

$$F_{X_i}(x) = 1 - e^{-\lambda_i x} \quad (3.30)$$

As a result, the reachability graph of a bounded SPN is isomorphic to a finite Markov Chain (MC) (Murata, 1989; Cassandras, 1993; Desrochers, 1992; Gross and Harris, 1998). An SPN can be analyzed by considering all possible markings (enumerations of the tokens in each place) and solving the resulting reachability graph as a Markov Chain.

Consider the well-known example of a producer-consumer system with two processes, one that produces data and places it into the (infinite) queue and the second

that reads the data from the queue and consumes it. Figure 3.6 shows the SPN model of this system. Places *process\_1* and *process\_2* model the state when either process is ready to write and read from the queue respectively (denoted by the presence of a token in those places). Transitions *write* and *read* perform the function of actually writing data and reading data from the queue respectively. The temporal characterization of these two transitions is based on assumptions about the duration of such operations; the choice of immediate transitions here amounts to neglecting the delays inherent in such operations. The queue is denoted by the place *queue*. The number of tokens in this place indicates the number of data values available for reading. When there is no token in this place, the transition *read* is not enabled and hence nothing can be read from the queue. Places *producer* and *consumer* indicate the state when the processes are ready to produce the data and process the data read respectively. Transitions *produce* and *consume* perform the function of actually producing and consuming the data. The temporal characterization of these two transitions is again derived by assumptions about the duration of such processing.

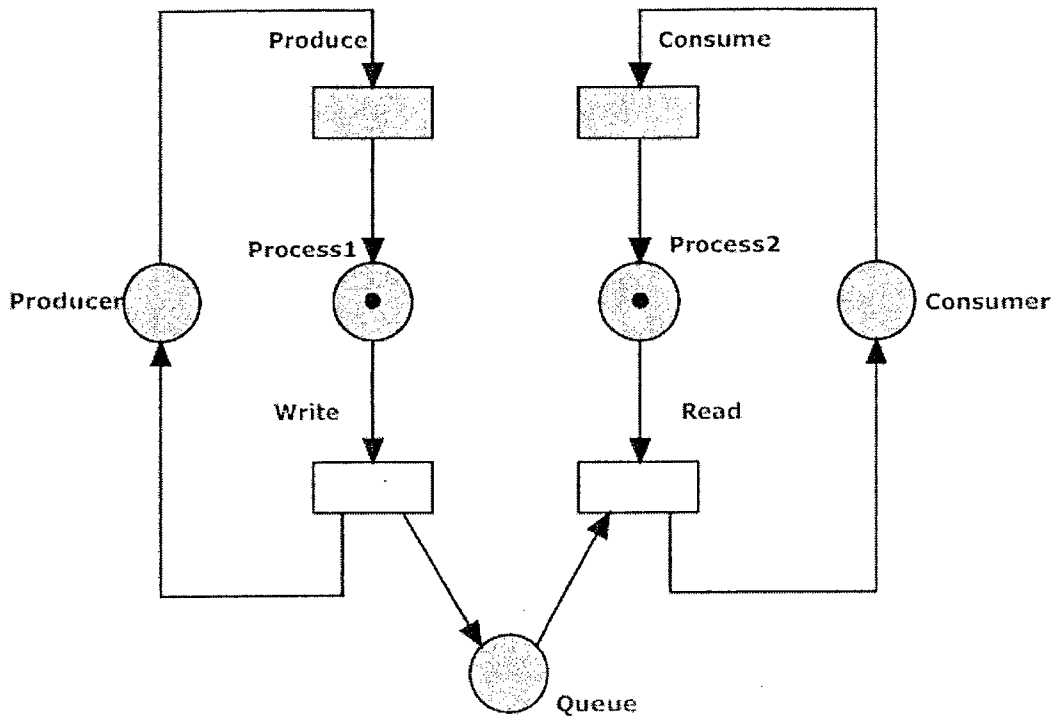

Figure 3.6: Example of a SPN model (Jerath, 2002)

### 3.2.2.2 Fuzzy Petri Nets

In general, a Fuzzy Petri Net is a method for representing uncertain knowledge about a system state which combines fuzzy set theory and Petri Net theory. A Fuzzy Petri Net is a bipartite directed graph which contains two types of nodes: places and transitions, where circles represent places and bars represent transitions. Each place may or may not contain a token associated with a truth value between zero and one. Each transition is associated with a certainty factor value between zero and one. The relationships from places to transitions and from transitions to places are represented by directed arcs. The status of one place can be changed because of cascading effects from other places. The concept of Fuzzy Petri Net is derived from basic Petri Net (Peterson, 1981).

According to notations adopted in Chen, Ke, and Chang (1990), a generalized Fuzzy Petri Net structure can be defined as an 8-tuple:

$$\text{FPN} = \{ P, T, D, I, O, f, \alpha, \beta \},$$

where  $P = \{p_1, p_2, \dots, p_n\}$  is a finite set of places,

$T = \{t_1, t_2, \dots, t_n\}$  is a finite set of transitions,

$D = \{d_1, d_2, \dots, d_n\}$  is a finite set of propositions,

$$P \cap T \cap D = \emptyset, |P| = |D|,$$

$I: T \rightarrow P^\infty$  is the input function, a mapping from transitions to places,

$O: T \rightarrow P^\infty$  is the output function, a mapping from transitions to places,

$f: T \rightarrow [0,1]$  is an association function, a mapping from transitions to real values between zero and one,

$\alpha: P \rightarrow [0,1]$  is an association function, a mapping from places to real values between zero and one,

$\beta: P \rightarrow D$  is an association function, a bijective mapping from places to propositions.

A Fuzzy Petri Net can be modeled as shown in Figure 3.7. Here,  $d_j$  and  $d_k$  are

propositions which may contain some fuzzy variables (Chen, 1988), such as “high,” “low,” “hot,” etc.  $\mu_i$  is the value of the certainty factor (CF),  $\mu_i \in [0,1]$ . It represents the strength of the belief in the rule. The larger the value, the more the rule is believed in.

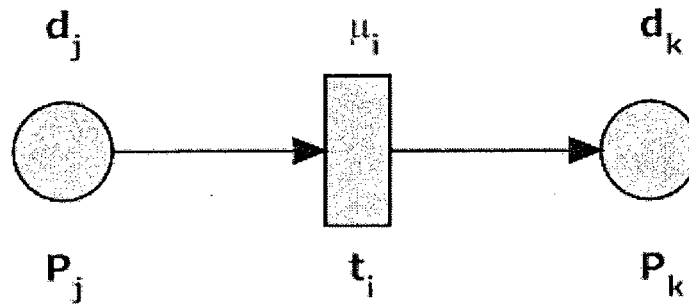

Figure 3.7: A Fuzzy Petri Net

A Fuzzy Petri Net with some places containing tokens is called a marked Fuzzy Petri Net. In a marked Fuzzy Petri Net, the token in a place  $p_i$  is represented by a labeled dot. The token value in a place  $p_i$ ,  $p_i \in P$ , is denoted by  $\alpha(p_i)$ , where  $\alpha(p_i) \in [0,1]$ .

In a Fuzzy Petri Net, a transition may be enabled to fire. A transition  $t_i$ , is enabled if for all  $p_j \in I(t_i)$ ,  $\alpha(p_j) \geq \lambda$ , where  $\lambda$  is a threshold value and  $\lambda \in [0,1]$ . A transition  $t_i$ , fires by removing the tokens from its input places and then depositing one token into each of its output places. According to Chen (1988) and Negoita (1985), the token value in an output place of  $t_i$  is calculated as  $y_k = y_i \times \mu_i$ .

Figure 3.8 shows an example of firing a Fuzzy Petri Net (Chen et al., 1990).

$$FPN = (P, T, D, I, O, f, \alpha, \beta)$$



$$P = \{P_1, P_2\}, T = \{t_1\}, D = \{\text{it is hot, the humidity is low}\}$$

$$I(t_1) = \{P_1\}, O(t_1) = \{P_2\}, f(t_1) = 0.9$$

$$\alpha(P_1) = 0.9, \alpha(P_2) = 0$$

$$\beta(P_1) = \text{it is hot}, \beta(P_2) = \text{the humidity is low}$$

If the token value of the proposition “it is hot” is 0.9, then after the rule fired, the token value of the proposition “the humidity is low” is  $0.9 \times 0.9 = 0.81$ . It indicates that the possibility of low humidity is 0.81.

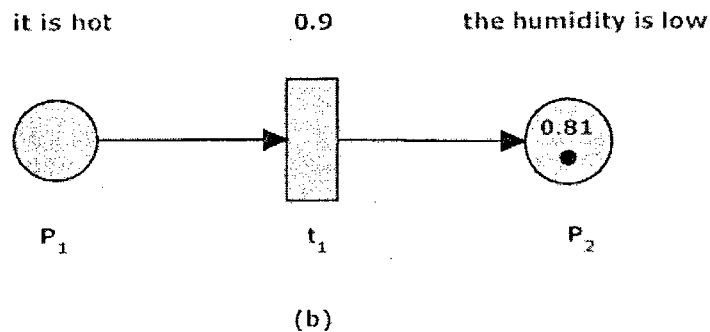
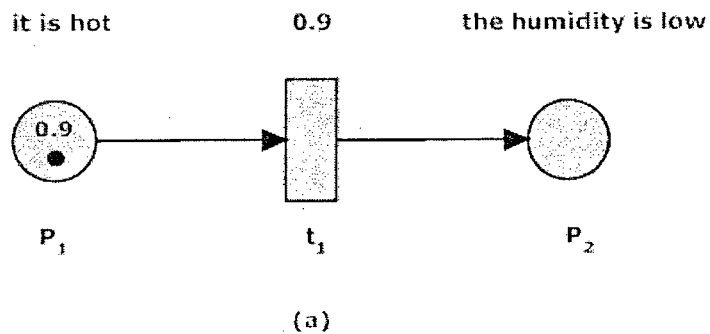

Figure 3.8: An example of firing a marked Fuzzy Petri Net (a) before firing and (b) after firing

(Chen et al., 1990)

If the Fuzzy Petri Net includes more multiple places and transitions with “and” or “or” connectors, then it is called a composite Fuzzy Petri Net rule. According to Looney and Alfize (1987), the composite Fuzzy Petri Net rule can be distinguished into the following four basic types shown in Figure 3.9, Figure 3.10, Figure 3.11, and Figure 3.12, respectively.

Type 1 rule: The token value in the output place of  $t_i$  is calculated as

$$y_k = \min(y_{j_1}, y_{j_2}, \dots, y_{j_n}) \times \mu_i.$$

Type 2: The token value in the output place of  $t_i$  is calculated as

$$y_{k1} = y_{k2} = \dots = y_{kn} = y_j \times \mu_i.$$

Type 3: The token value in the output place of  $t_{i_1}, t_{i_2}, \dots, t_{i_n}$  is calculated

$$\text{as } y_k = \max(y_{j_1} \times \mu_{i_1}, y_{j_2} \times \mu_{i_2}, \dots, y_{j_n} \times \mu_{i_n}).$$

Type 4: The token value in the output place of  $t_{i_1}, t_{i_2}, \dots, t_{i_n}$  is calculated as

$$y_{k1} = y_j \times \mu_{i_1}, y_{k2} = y_j \times \mu_{i_2}, \dots, y_{kn} = y_j \times \mu_{i_n}.$$

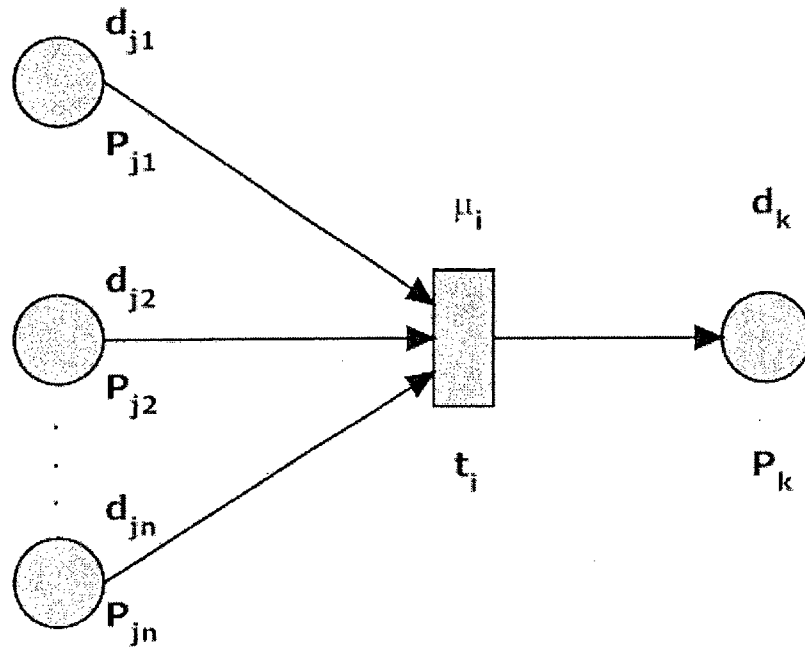

Figure 3.9: Representation of the type 1 rule in a Fuzzy Petri Net

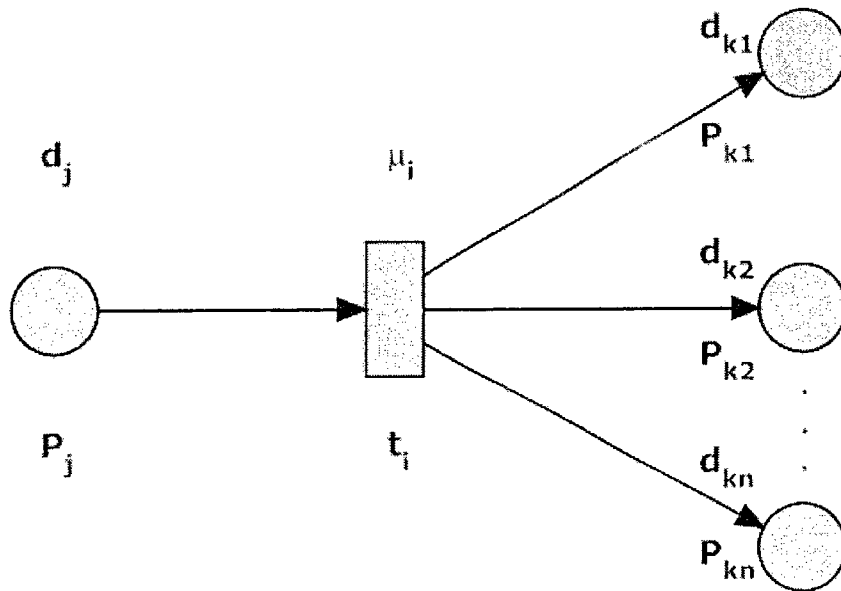

Figure 3.10: Representation of the type 2 rule in a Fuzzy Petri Net

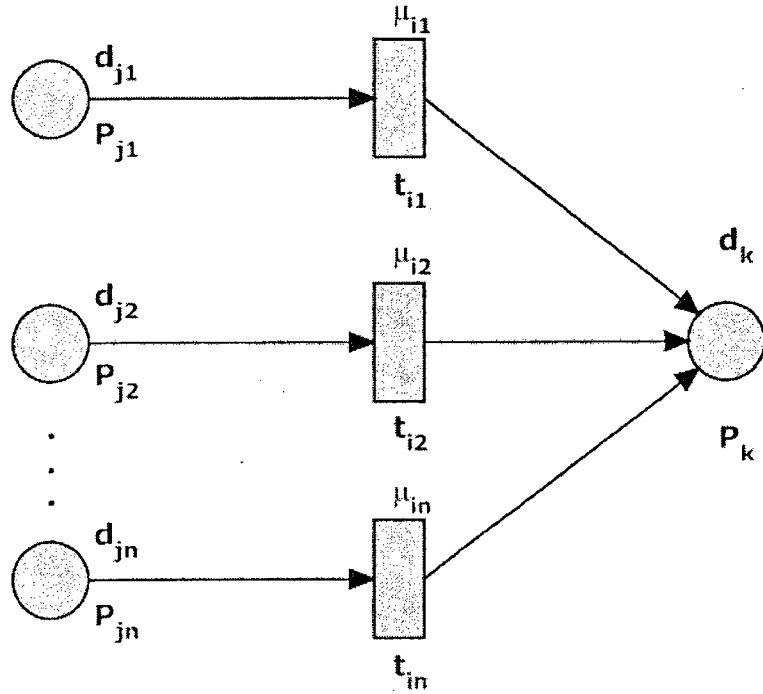

Figure 3.11: Representation of the type 3 rule in a Fuzzy Petri Net

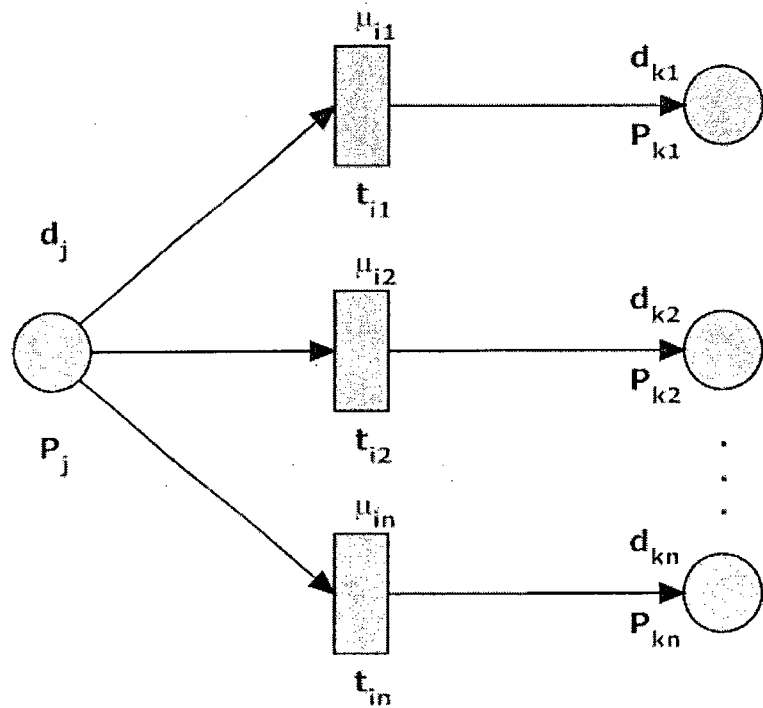

Figure 3.12: Representation of the type 4 rule in a Fuzzy Petri Net

### 3.3 Markov Chain Analysis

The FCEPN system uses Markov Chain analysis, which is based on the Extended Petri Net model, to predict the probability of the occurrence of different failure states for the infrastructure system.

The Markov Chain modeling concept is applied to predict the future probability of an event occurring based on the current situation. This modeling approach can simulate the long term trend of an event. Related theories have been addressed frequently by a number of studies (Howard 1971, Kemeny et al. 1974, Grinstead and Snell 1997). Formally, a Markov Chain is a system that can be in one of several states and can pass from one state to another each time step in a dynamic way according to the fixed probabilities which can be determined from the trends of the states. For example, if a Markov Chain is currently in state '*i*', it can pass to another state '*j*', with the probability  $T_{ij}$  which is called a "transition probability". Thus, a Markov Chain can be illustrated by means of a "state transition diagram" showing all the states and transition probabilities.

A Markov Chain may contain the transient state and absorbing state. Absorbing states are those states from which there is no output, which means, these states are absorbed within themselves. This Markov Chain can be separated into transient and absorbing states according to the following canonical form:

$$T_r = \begin{matrix} Q & : & R \\ \dots & : & \dots \\ 0 & : & I \end{matrix} \quad (3.31)$$

where,  $I$  is the identity matrix of absorbing states,  $0$  is a zero matrix,  $Q$  is the transient matrix, and  $R$  is the remaining matrix.

The fundamental matrix is:

$$N = (I - Q)^{-1} \quad (3.32)$$

where,  $N$  indicates the expected number of times in transient states for starting at the different states before being absorbed.

If  $b_{ij}$  is the probability that an absorbing chain will be absorbed in the absorbing state  $s_j$  which starts in the transient state  $s_i$ , and,  $B$  is the matrix with entries  $b_{ij}$ , then,

$$B = N \times R \quad (3.33)$$

Thus, the steps for Markov Chain analysis based on the Extended Petri Net can be summarized as followed:

1. The Markov Chain diagram can be developed with the transition probability based on the reachability graph derived from the Extended Petri Net.
2. The transition matrix can be generated from the Markov Chain diagram.
3. The fundamental matrix can be calculated based in the transition matrix.
4. The matrix of the probability of reaching the absorbing states from the transient states can be generated by the Equation 3.33.

### 3.4 Integrated Modeling and Analysis through the FCEPN

#### System

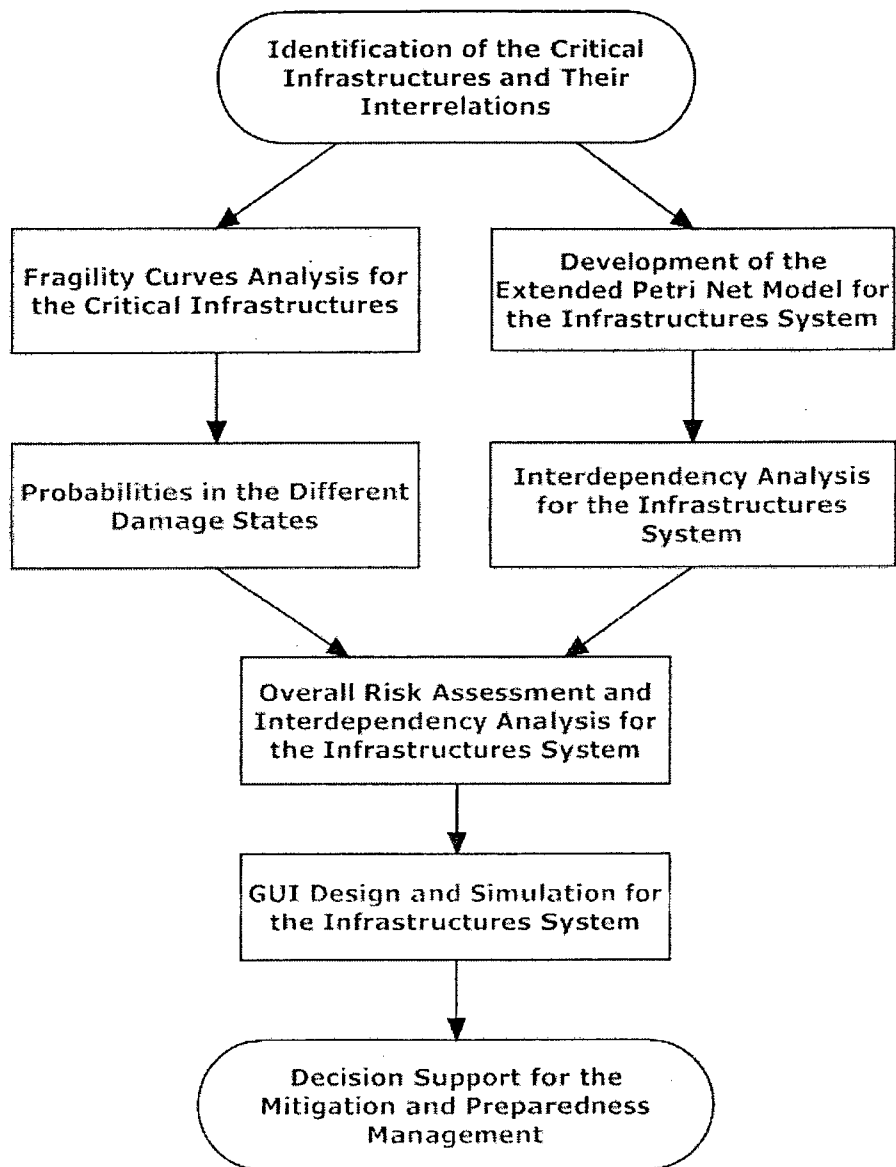

Figure 3.13: The flowchart of the development of the FCEPN system

A network-based system called FCEPN is developed in this chapter and it has two modules: Fragility Curve analysis module and Extended Petri Net analysis module. These

two modules are integrated to analyze the overall vulnerability of the infrastructure system and to address the interdependency among infrastructures or components. Specifically, the Fragility Curve analysis will be used to analyze the vulnerability of a single infrastructure, e.g. a dam; the basic Petri Net analysis will be applied to address the interdependency relationships among infrastructures system and qualitative evaluation of infrastructure interdependency; and dynamic network analysis will be performed with extended Petri Net model. For example, the Fragility Curve analysis for the primary infrastructure provides a first independent assessment of the overall vulnerability assessment for the whole infrastructure system, then the Stochastic Petri Net is converted into a Markov Chain. Properties and characteristics of the developed Markov Chain will be determined to examine the safety of the network infrastructures. The flowchart of the development of the FCEPN system is provided in Figure 3.13. Thus, the FCEPN system can contribute to the emergency management of the critical infrastructures.

Two different types of “infrastructure interdependency” will be studied with case studies. The first case of infrastructure network represents the network of dam-related infrastructures (single dam) which is an integral part of the civil society; disruptions of these infrastructures cause severe impacts on the community. The second kind consists of multiple interconnected dams infrastructures; the failures of upstream dam result in a cascading or domino effect on the downstream dams. For these two infrastructure networks, a vulnerability assessment of the primary infrastructure will be performed and the network modeling and extended analysis will be applied for interdependency and safety assessment. The results from these analyses will be integrated for predicting the overall vulnerability of infrastructures network.



In this chapter, various related theories of Fragility Curve analysis, basic Petri Net and extensions as well as Markov Chain which were proposed previously by researchers in these fields were discussed. Some improvements and complementary approaches based on previous studies are presented that were used to develop the FCEPN system. For example, the drainage effectiveness for the dam is considered in the Fragility Curve analysis; the calculation of the damage factors and the definition of the damage states are more reasonable; for the Extended Petri Net analysis, two types Extended Petri Nets (Stochastic Petri Net and Fuzzy Petri Net) are discussed to address the interdependency and vulnerability of the infrastructure system for different cases; the user friendly graphic user interface (GUI) is developed in order to integrate the proposed methods into a useful decision tool and to facilitate the application of the FCEPN system.

In order to evaluate the FCEPN system which was proposed in this chapter, the FCEPN system will be applied to two case studies in Chapters 5 and 6. In Chapter 5, the Bluestone Dam in the North America will be considered as a case study. In Chapter 6, the multiple-dam system of the Huai River in China will be discussed as the other case study. In addition, the development of the GUI system will be introduced in Chapter 4.

# **CHAPTER 4 DEVELOPMENT OF A USER-FRIENDLY GRAPHICAL USER INTERFACE (GUI) FOR THE FCEPN SYSTEM**

## **4.1 Introduction**

The FCEPN system is developed in this study, which integrates Fragility Curve and Extended Petri Net analyses for risk assessment and interdependency analysis of infrastructure systems and their components with respect to failure due to natural hazards. In order to make the modeling system friendly for users to easily access and visualize the simulation information, a graphical user interface (GUI) system is designed in this chapter for the FCEPN system to interact with users. Figure 4.1 presents an overview of the design for the GUI system. The system includes the following components: Fragility Curve and Extended Petri Net modules, an input system, and an output system.

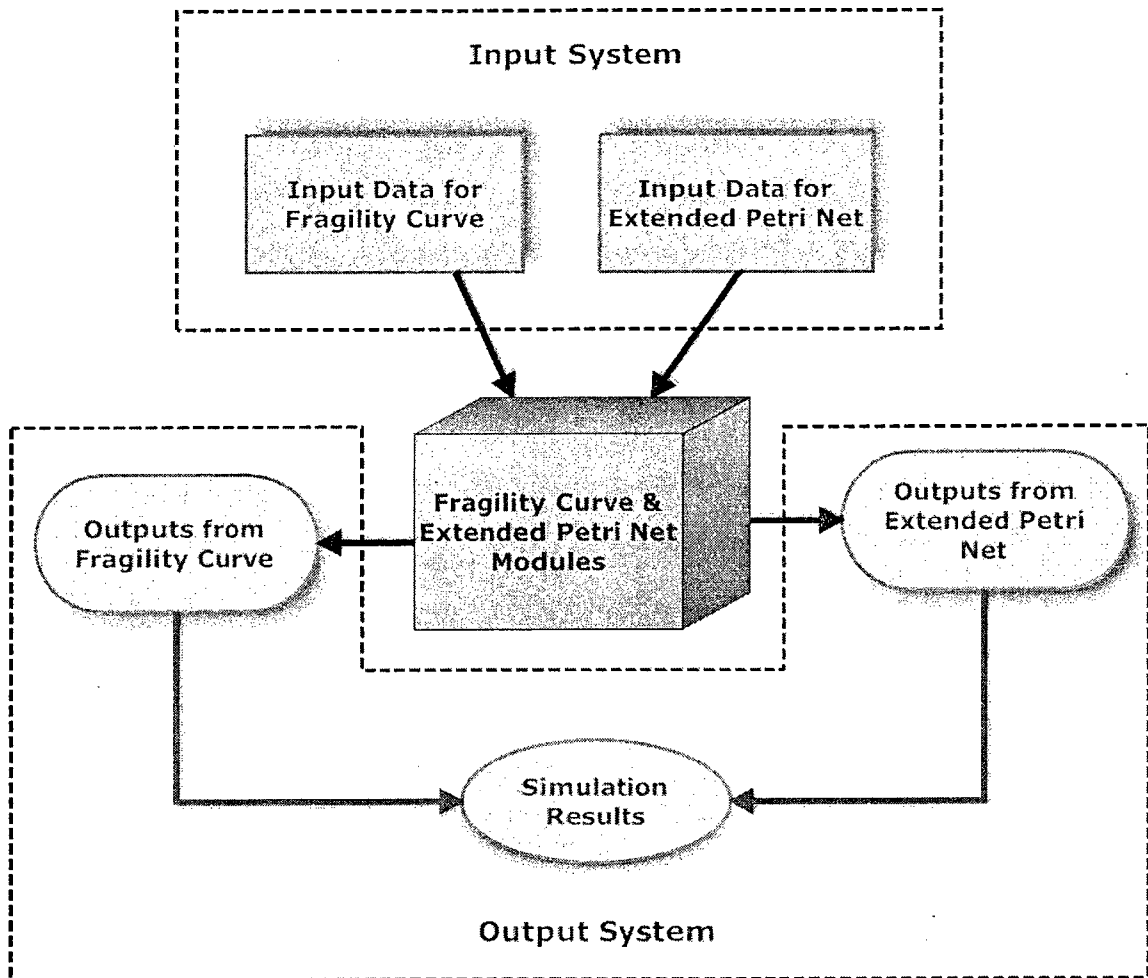

Figure 4.1: Schematic diagram of the FCEPN system (The dotted lines show the GUI system developed to integrate the Fragility Curve and Extended Petri Net analyses)

This GUI is based on the mathematic software MATLAB. The MATLAB<sup>®</sup> Graphical User Interface development environment provides a set of tools for creating graphical user interfaces (GUIs). These tools greatly simplify the process of designing and building GUIs. We use these tools to lay out the GUI system for easy operation of the modeling system. The user interacts with the GUI system by communicating requirements and manipulating functional modules to obtain the expected results. With the help of this software, it is possible to systematically study the interdependency among

infrastructures and their components as well as the vulnerability of the infrastructures.

Two application models were built for the FCEPN system, which are Dam SPN and Dam FPN. For the Dam SPN model, we integrated Fragility Curve analysis and Stochastic Petri Net together to study the interdependencies among dam-related infrastructure components and their vulnerabilities. Fragility Curve analysis can easily indicate the damage probabilities of the critical infrastructure (e.g. one dam) at the time of a given hazard (e.g. high water levels). The Stochastic Petri Net model can clearly present the interrelation and cascading influence among the infrastructures of the system if one of the components has completely failed, that is, the failure of this component is deterministic. For example, the failed dam will have a different influence on the penstock, power plant and power lines. In this case, the critical infrastructure (e.g. one dam) could be a key element to link the Fragility Curve and Stochastic Petri Net to become an integrated model to effectively simulate the infrastructures interdependencies. Thus, we can predict the cascading impact on the infrastructure system directly by the easier defined hazard (e.g. high water levels) applied to the critical infrastructure (e.g. one dam).

For the Dam FPN model, we integrated Fragility Curve analysis and Fuzzy Petri Net together to study the interdependency among multiple-dams/sluices and their risk assessment. Fuzzy Petri Net is another extension of basic Petri Net. In this model, we can study the possibility of collapse of multiple-dams/sluices at a given upstream water level by Fragility Curves analysis. Then, we use the Fuzzy Petri Net model to address the domino effects among the multiple-dams/sluices and the risk values of the dams/sluices.

## 4.2 GUI Design

### 4.2.1 System main interface

The system main interface is the main interface of the FCEPN system, and it is the interactive platform between user and system, supplying two-way communication between user and system (Figure 4.2). There are two buttons in this interface, which are “Dam SPN” and “Dam FPN”. They represent the two models of the FCEPN system. The Dam SPN model integrates Fragility Curve and Stochastic Petri Net, whereas, the Dam FPN model integrates Fragility Curve and Fuzzy Petri Net.

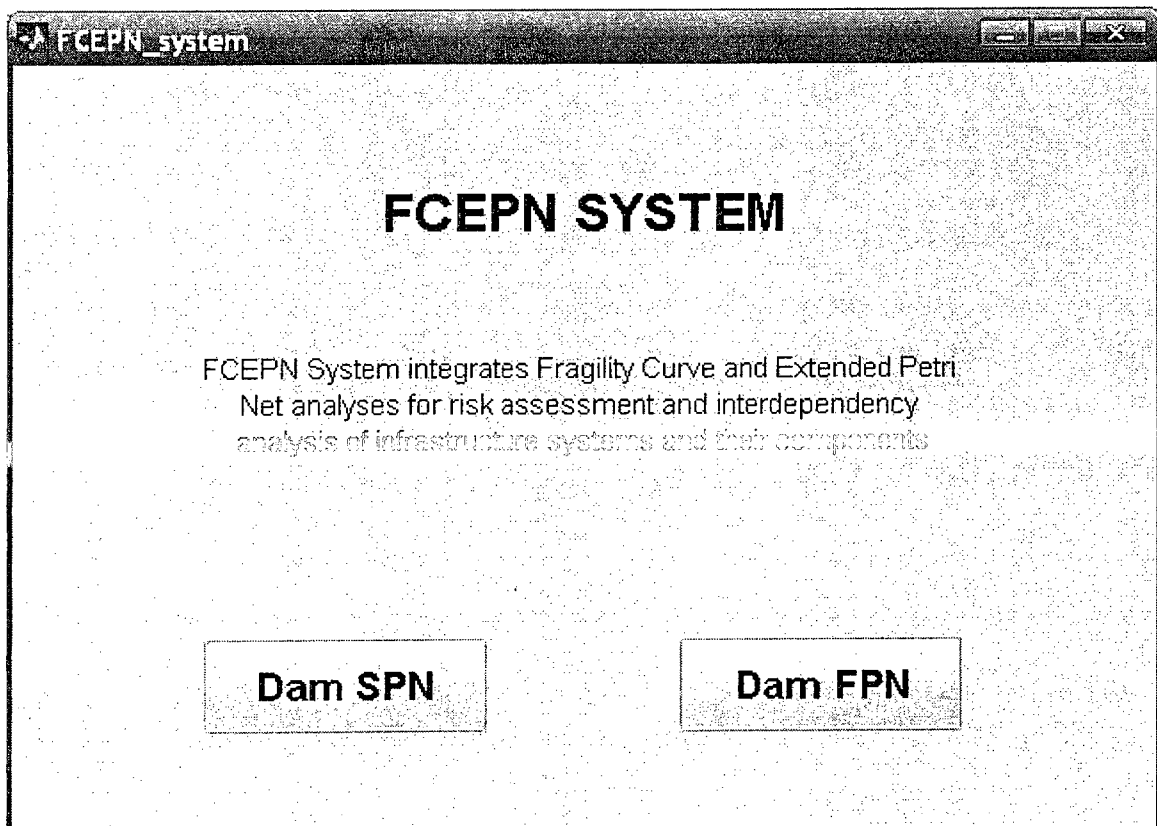

Figure 4.2: The FCEPN system main interface

## 4.2.2 Dam SPN model interface

After clicking the button “Dam SPN”, we enter the Dam SPN model interface (Figure 4.3). There are three menu commands in the Dam SPN interface, which are “Input”, “Output”, and “Simulation”. In the “Input” menu, there are two function menus: FC Input (including DS1-DS4) and SPN Input. In the “Output” menu, there are two function menus: FC Output (including DS1-DS4 and Overall) and SPN Output (Figure 4.4 and Figure 4.7). The user can click on the menu bar to enter the input interface, output interface and simulation interface.

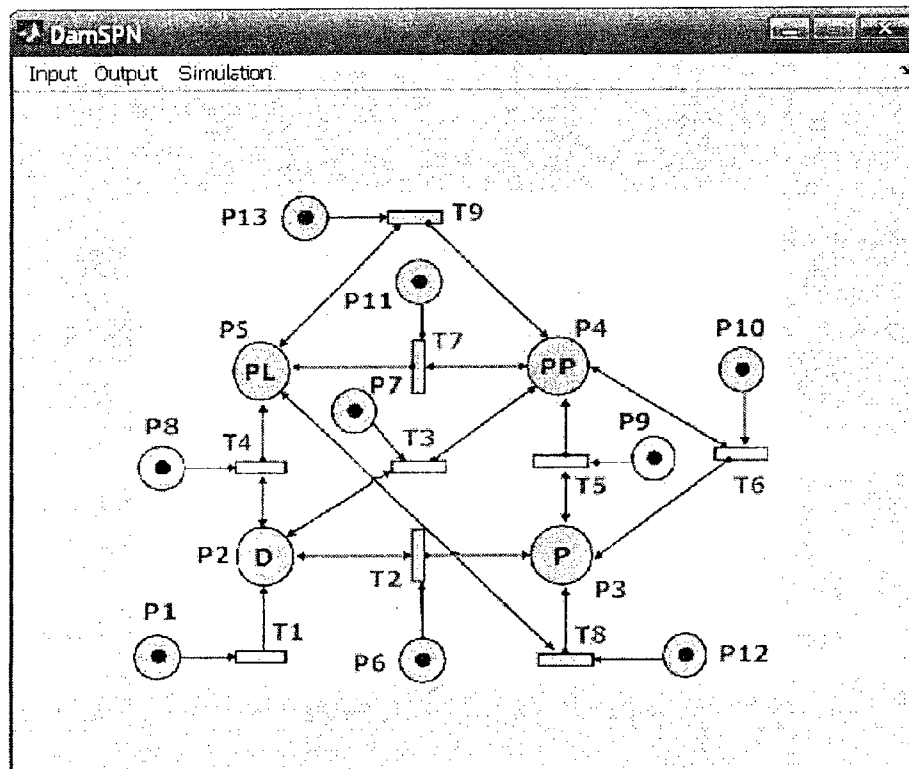

Figure 4.3: The Dam SPN model interface

### 4.2.2.1 Input menu

The input menu command in the Dam SPN model includes two parts: input data for Fragility Curve and input data for Stochastic Petri Net (Figure 4.4). For the input data of Fragility Curve, we defined four damage states (DS1~DS4) according to previous research terminology.

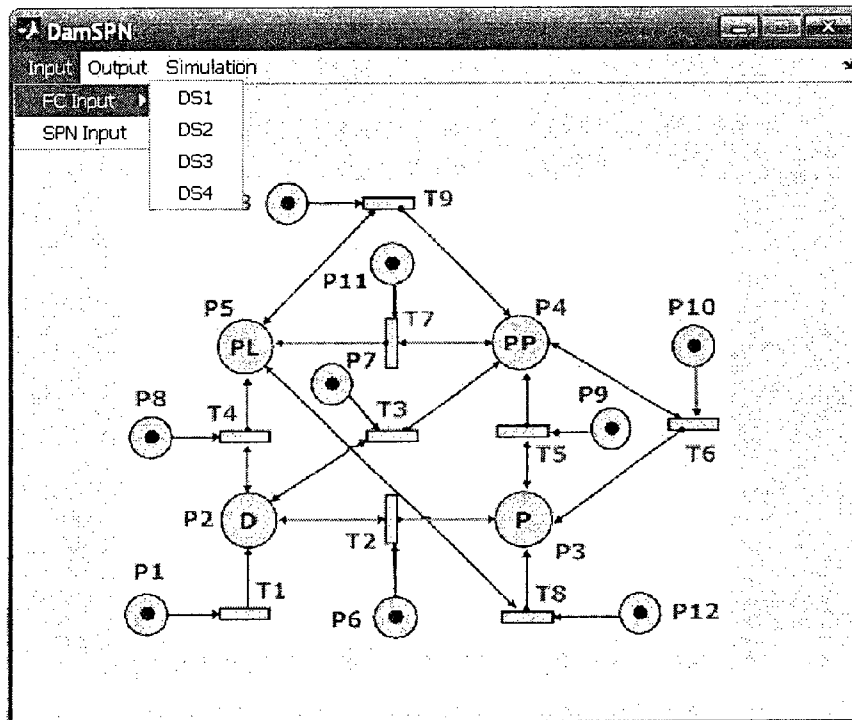

Figure 4.4: Input menu of the GUI for the Dam SPN model

Figure 4.5 presents the GUI for the input of the Fragility Curve simulation parameters. Three groups of parameters are required:

1. Geometric parameters of the dam: height, width and slope of the dam;
2. Material properties: specific weight of the dam and water;
3. Water level: upstream water level.

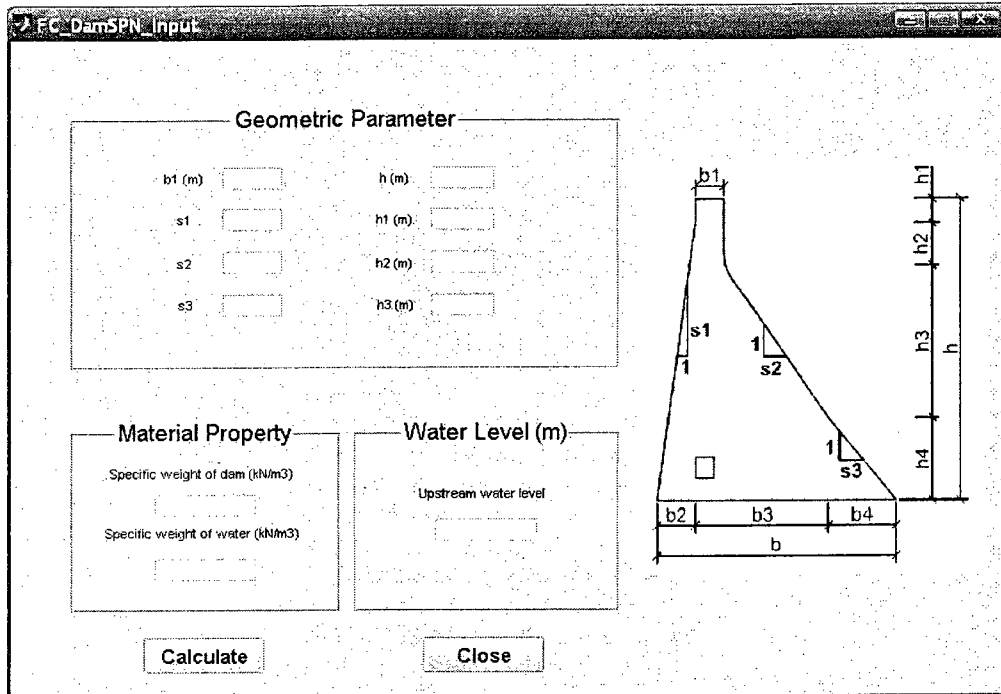

Figure 4.5: Input interface for Fragility Curve analysis in the Dam SPN model

After inputting all the required data for the Fragility Curve simulation, Click “Calculate”, these data will input into the program to produce the Fragility Curve. Click “Close”, this window will be closed.

Figure 4.6 presents the GUI for the input of state probability for the Stochastic Petri Net. After inputting all the input parameters for the Stochastic Petri Net simulation, Click “Calculate”, these data will input into the program to produce the failure probability for the different failure states. Click “Close”, this window will be closed.



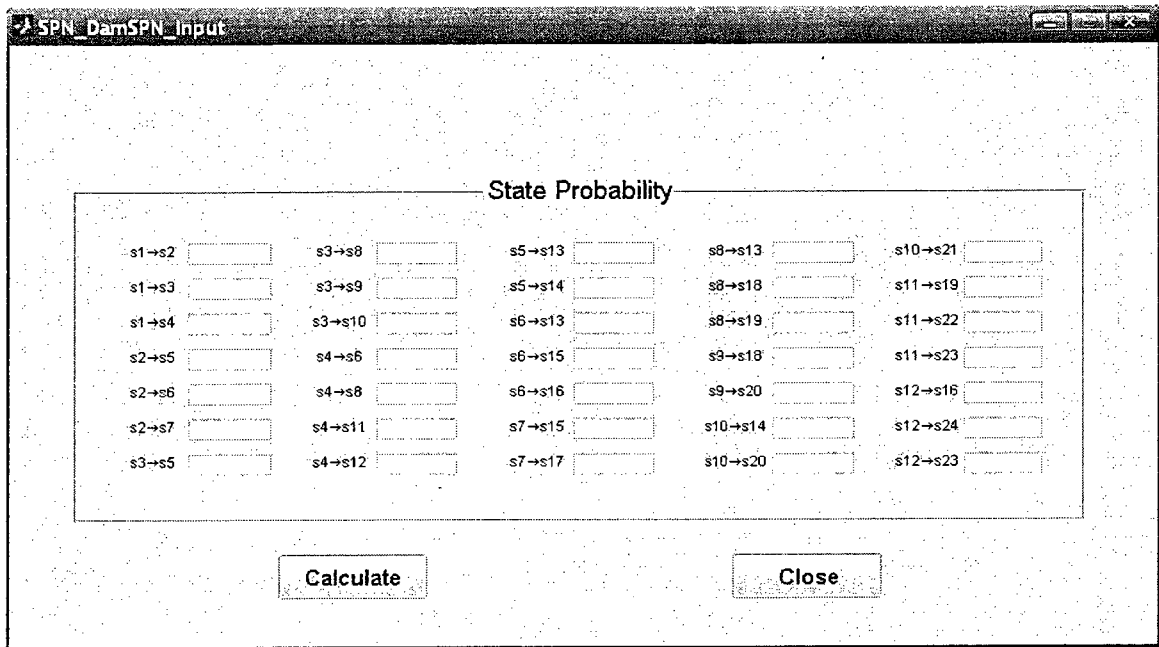

Figure 4.6: Input interface for Stochastic Petri Net analysis in the Dam SPN model

#### 4.2.2.2 Output menu

The output menu command in the Dam SPN model includes two parts: output results for Fragility Curve and output results for Stochastic Petri Net (Figure 4.7). For the output results of Fragility Curve, we also have different four damage states (DS1~DS4) corresponding to input menu commands.

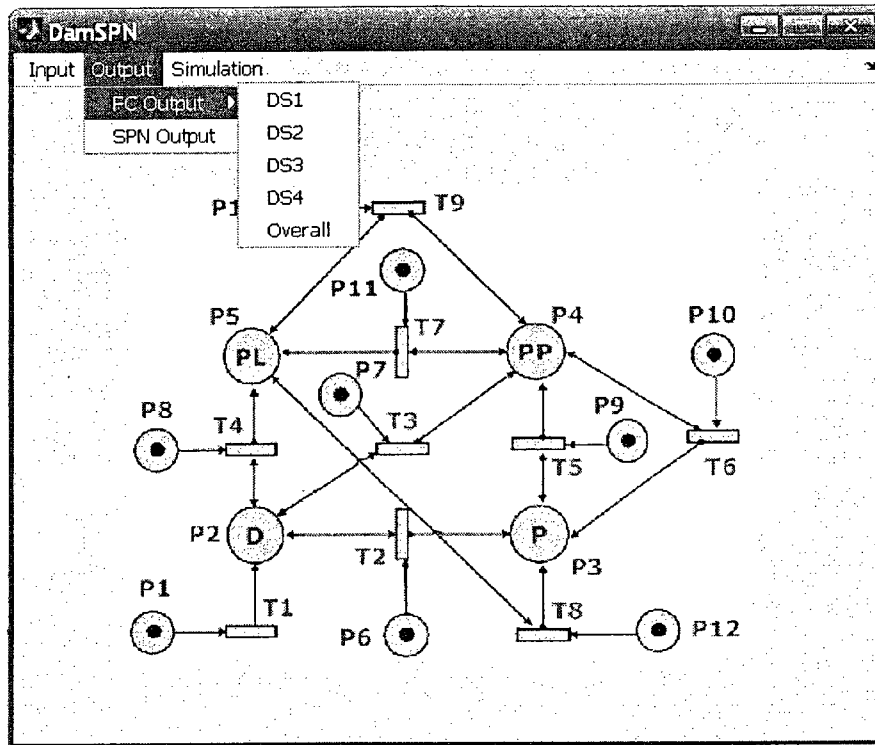

Figure 4.7: Output menu of the GUI for the Dam SPN model

The GUI system can output all of the results for Fragility Curve and Stochastic Petri Net model. For instance, the GUI system can plot all of the Fragility Curves for four damage states respectively. Also the GUI system can output the results of Stochastic Petri Net model to indicate the interdependencies among the infrastructures.

#### 4.2.2.3 Simulation menu

We can also simulate the above results using the simulation interface of the GUI system. In this model, four damage states classifications, which are slight (DS1), moderate (DS2), severe (DS3), and collapsed (DS4), are extended according to the four limited states of the dam. In the Stochastic Petri Net analysis, the derived 12 absorbing states indicate the same condition; that is, all the infrastructures in the network are out of

service, but they are attained in different ways. Thus, we can obtain the infrastructure interdependencies of 12 absorbing states at a given water level for each of damage states. Figure 4.8 shows all of the possible options for infrastructures interdependencies simulation. The user can select any water level in the pop-up menu, and plot the corresponding probability distribution figure.

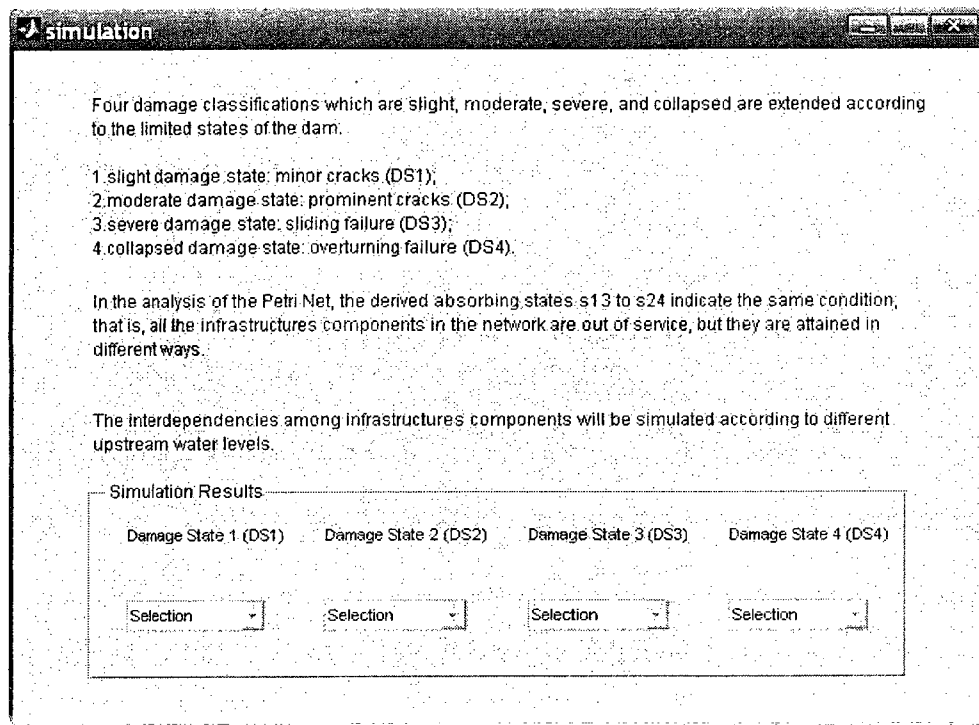

Figure 4.8: Simulation interface in the Dam SPN model

### 4.2.3 Dam FPN model interface

When the user selects the “Dam FPN” option, the program will transfer to the Dam FPN model (Figure 4.9). There are two menu commands in the Dam FPN interfaces, which are “Input” and “Output”. In the “Input” menu, there are two function menus: FC Input (including DS1-DS4) and FPN Input. In the “Output” menu, there are two function

menus: FC Output (including DS1-DS4 and Overall) and FPN Output (Figure 4.10 and Figure 4.13). The user can click the menu bar to enter the input interface and output interface.

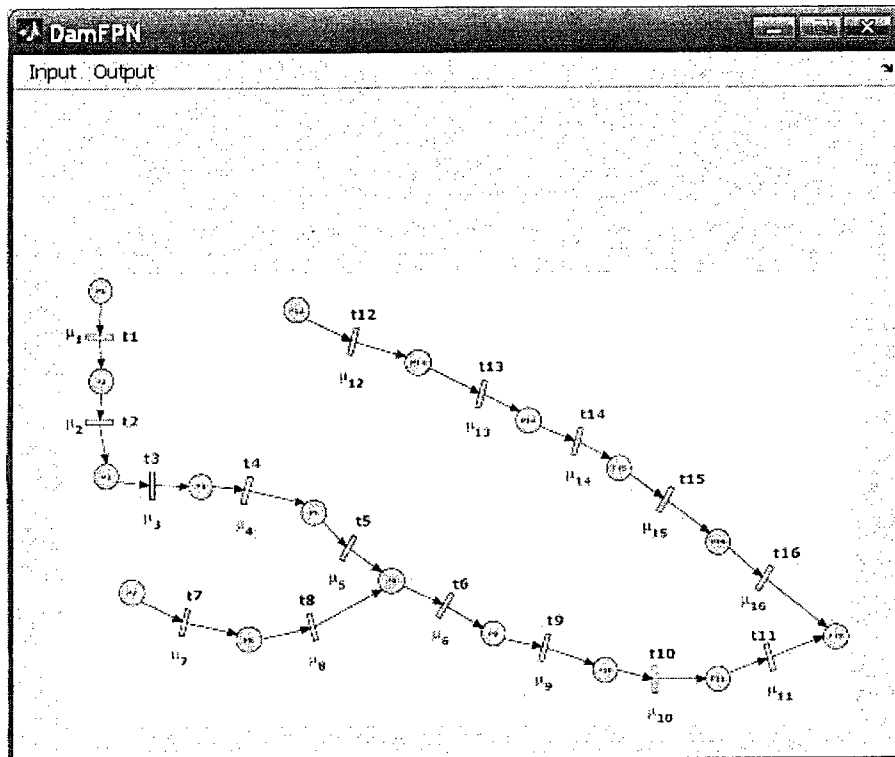

Figure 4.9: Dam FPN model interface

#### 4.2.3.1 Input menu

The input menu command in the Dam FPN model includes two parts: input data for Fragility Curve and input data for Fuzzy Petri Net (Figure 4.10). For the input data of Fragility Curve, we also defined four damage states (DS1~DS4) according to previous research terminology.

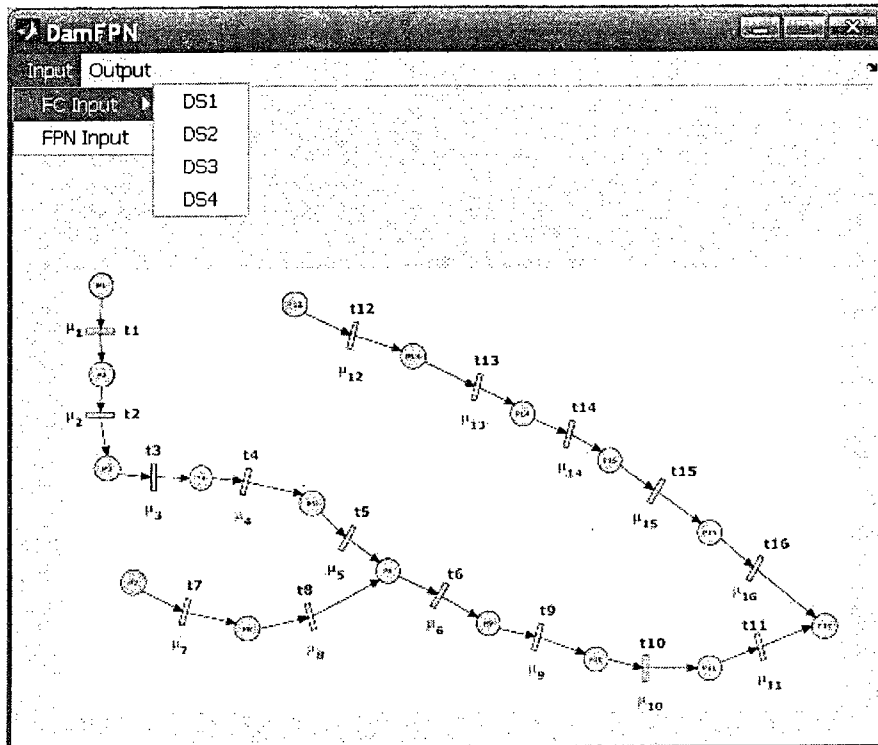

Figure 4.10: Input menu of the GUI for the Dam FPN model

The screenshot shows the 'FC\_DamFPN\_Input' application window. It is divided into three main sections: 'Geometric Parameter', 'Material Property', and 'Water Level (m)'.  
 - **Geometric Parameter:** Contains input fields for  $b1$  (m),  $h$  (m),  $s1$ ,  $s2$ ,  $s3$ ,  $h1$  (m),  $h2$  (m), and  $h3$  (m).  
 - **Material Property:** Contains input fields for 'Specific weight of dam (kN/m<sup>3</sup>)' and 'Specific weight of water (kN/m<sup>3</sup>)'.  
 - **Water Level (m):** Contains an input field for 'Upstream water level'.  
 At the bottom, there are 'Calculate' and 'Close' buttons. To the right of the input fields is a diagram of a dam cross-section. The diagram shows a trapezoidal dam with a top width  $b1$ , a bottom width  $b$ , and a total height  $h$ . The dam is divided into three vertical sections with widths  $b2$ ,  $b3$ , and  $b4$ . The slopes are labeled  $s1$ ,  $s2$ , and  $s3$ . The height is divided into four sections:  $h1$ ,  $h2$ ,  $h3$ , and  $h4$ . A small square is shown on the upstream face of the dam.

Figure 4.11: Input interface for Fragility Curve analysis in the Dam FPN model

Figure 4.11 presents the GUI for the input of the Fragility Curve simulation parameters. Three groups of parameters are also required:

1. Geometric parameters of the dam: height, width and slope of the dam;
2. Material properties: specific weight of the dam and water;
3. Water level: upstream water level.

After we input all the data for the Fragility Curve simulation, Click “Calculate”, these data will input into the program to produce the Fragility Curve. Click “Close”, this window will be closed.

If we need to simulate the Fragility Curves of several dams in a multiple-dam system, we can just repeat this procedure for many times, each time, clicking “Calculate” will produce a new Fragility Curve result with different input parameters.

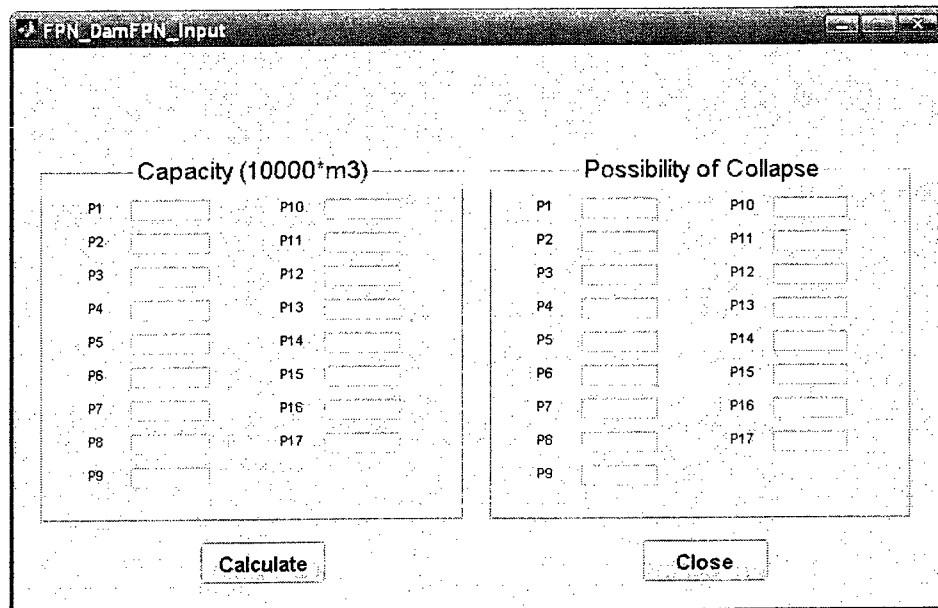

Figure 4.12: Input interface for Fuzzy Petri Net analysis in the Dam FPN model

Figure 4.12 presents the GUI for the input data for the Fuzzy Petri Net. There are two types input data: capacity of the dam/sluice and possibility of collapse of the dam/sluice. After we input all the data for the Fuzzy Petri Net analysis, Click “Calculate”, the data will input into the program to produce the results for Fuzzy Petri Net analysis. Click “Close”, this window will be closed.

#### 4.2.3.2 Output menu

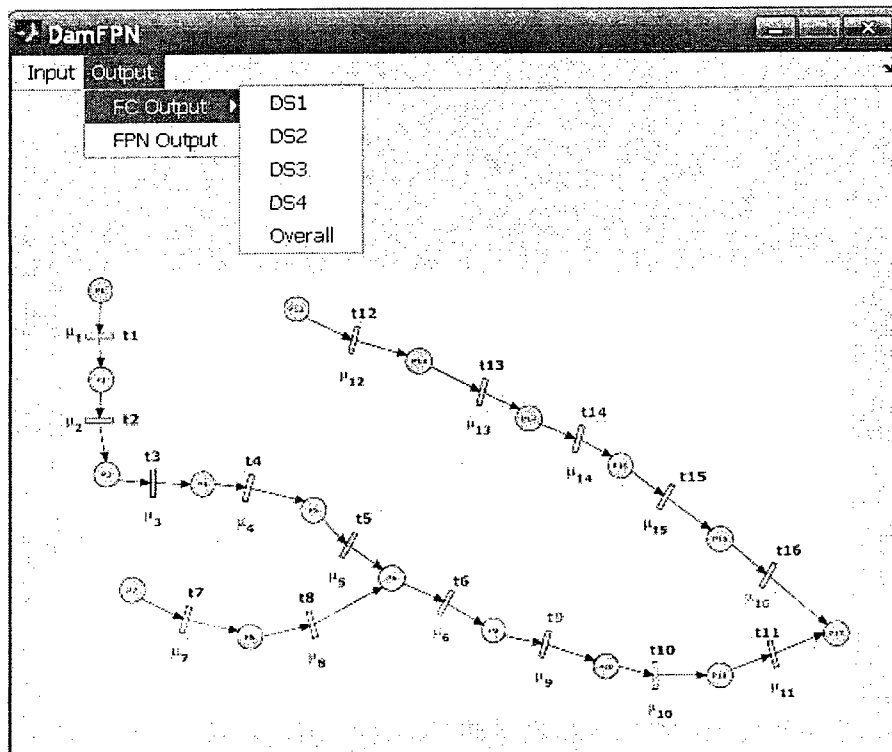

Figure 4.13: Output menu of the GUI for the Dam FPN model

The output menu command in Dam SPN model includes two parts: output results for Fragility Curve and output results for Fuzzy Petri Net (Figure 4.13). For the output results of Fragility Curve, we also have different four damage states (DS1~DS4) corresponding to input menu command.

The GUI system can output all of the results for Fragility Curve and Fuzzy Petri Net model. For instance, the GUI system can plot all of the Fragility Curves for four damage states respectively. Also the GUI system can output the results of Fuzzy Petri Net model to indicate the risk values of the dams/sluices.

### **4.3 Summary**

This chapter presents the development of FCEPN system for infrastructure interdependency analysis and vulnerability assessment. It introduces the integrated approach for FCEPN system development, development of the GUI, database, model base, data display system and development of the simulation system.

The FCEPN system that integrates multiple models is more effective than separate applications for each model. It includes two major application models (Dam SPN and Dam FPN) for dam-related infrastructure interdependency analysis and vulnerability assessment. The integrated system is performed using Fragility Curve analysis, Extended Petri Net as a common platform for database management, model base, and interface management. The design of the system is based on the software MATLAB.

First, a multiple-level interface has been developed, through which the database, the model base, and simulation system are integrated. MATLAB software are used for developing the client side user interfaces, serving for data input, interactively generating alternatives, evaluating alternatives, and displaying simulation results by tables and graphs.



Then, two application models are developed in this system: Dam SPN and Dam FPN. The distributed database for the model's inputs, running and results are required. The system includes a distributed database, allowing data acquisition from various agencies for model running. All model results are converted into tables or graphs so that users can easily visualize them.

In order to evaluate and validate this user-friendly GUI for the FCEPN system, in next chapters, this user-friendly system is applied to two case studies in North America and China to assess the risks of the infrastructures and analyze the interdependency among the related infrastructures or their components. The North America case study is selected to evaluate the Dam SPN model in the FCEPN system (detailed in Chapter 5), and the other Dam FPN model is tested by the China case study (detailed in Chapter 6).

# **CHAPTER 5 CASE STUDY 1: BLUESTONE DAM**

## **CASE STUDY USED TO BUILD THE DAM BL**

### **MODEL BASED ON THE STOCHASTIC PETRI NET**

#### **METHOD**

#### **5.1 Definitions**

In this study, we describe a model system (FCEPN), which was evaluated using a case study based on the Bluestone Dam in West Virginia. A simplified schematic model of the Bluestone Dam infrastructure system was constructed, called the Dam BL model (see Figure 5.1), consisting of: a) a hydraulic dam (D); b) geographically closely associated power plant (PP); c) penstock (P), an infrastructure component linked to both the dam and the power plant; and d) power lines (PL), an infrastructure component linked to the power plant and the penstock. We refer to (a)-(d) as components of the dam infrastructure system.

In terms of infrastructure component interdependencies, for the Dam BL model, we define the dam as the primary infrastructure and the other system components as being dependent on the dam. We define four damage states for the dam based on previous published work (see below). We define the concept of system “failure paths” as different possible scenarios that could result due to dam failure; the failure paths vary in the order in which the system components fail, due to their interdependencies.

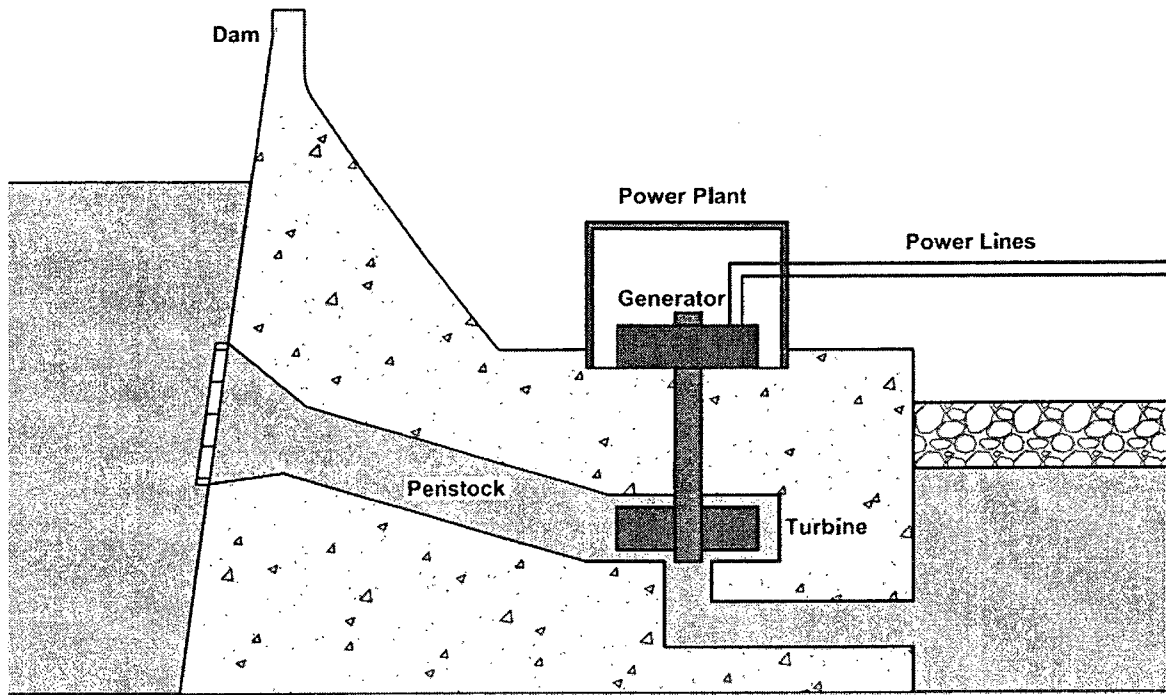

Figure 5.1: Dam BL model based on the Bluestone Dam (Ellingwood and Tekie, 2001), showing the various interacting infrastructure components of the system

## 5.2 Description of Interdependent Components in the Dam

### BL Model

Generally, a dam (D) is used for storing reservoir water for various purposes. When a dam overflows or collapses due to a high flood flow, high pressure from the floodwater leads to the rupture of penstock (P). Inundation from flood water causes malfunction or failure of the power plant (PP) and power lines (PL). A penstock (P) is a pipe conduit or tunnel with large diameter that carries a rapid flow of water to the hydroelectric power plant (PP). If penstock (P) does not function properly, malfunction of the penstock (P) leads to the shutdown of the power plant (PP). The power plant (PP) consists of the turbines, shafts, and generators for producing electricity. The electricity

produced is sent to the recipients by power lines (PL). If the generators are not capable of rotation, the penstock (P) operation has to be stopped down. In the Dam BL model, the penstock (P) operation and maintenance requires the availability of electricity provided by the power lines (PL). If the power lines (PL) are damaged or fail, they will not be able to conduct the electricity produced; consequently, the turbines in the power plant (PP) have to be stopped to avoid any accidental risks.

## **5.3 Bluestone Dam and the Corresponding Dam BL**

### **Schematic Model**

We chose the Bluestone Dam (West Virginia) for one of the case studies used to evaluate the FCEPN system because of the availability of a large historical database (Ellingwood and Tekie, 2001) as well as a detailed hydraulic and structural model of the dam (Linsley and Franzini, 1992). A simplified model of the Bluestone Dam was built (Dam BL) shown in Figure 5.1, using general information available on dams, as well as specific information cited above for the Bluestone Dam. In this complex infrastructure model system, the primary infrastructure (PI) is the dam (D); the secondary infrastructure (SI) is the power plant (PP). The power lines (PL) and penstock (P) are associated system components and are not considered major infrastructures in this schematic model. The penstock is linked to both the dam and the power plant, and the power lines are linked to both the power plant and the penstock. However, the power lines are not linked to the dam.

For any dam, if the impact on the dam due to increased water level becomes so

severe that the eccentricity of the resultant force is outside of the kern, then tension cracks develop at the heel of the dam; if the impact is so severe that the eccentricity of the resultant force is less than 1/4 of the width of the dam base (B) or greater than 3/4 of B, cracks spread out through the dam and become more prominent. At the same time, a sliding failure may take place at the dam-foundation interface. When the damage is extreme, overturning of the dam occurs (Ellingwood and Tekie, 2001).

To simplify the Dam BL model to test the FCEPN approach, we consider high water flooding as the only “hazard” of the primary infrastructure (dam) (O’Rourke et al., 2000), and do not consider other forms of damage or natural disasters. We define four damage states (DS) of the dam based on increasingly high water levels, similar to those used previously by the U.S. Army Corps of Engineers for designing dams.

## **5.4 Development of Fragility Curves for Damage States of the Primary Infrastructure**

The detailed hydraulic and structural model described by Linsley and Franzini (1992) was used for analytical Fragility Curves development for the dam in our case study. We used the general framework shown in Figure 3.1 for Fragility Curve development for the primary infrastructure (the dam in schematic model Dam BL, Figure 5.1) using historical data for the Bluestone Dam which included the: a) geometrical shape of the dam; b) upstream water levels; and, c) properties of the structural materials (Ellingwood and Tekie, 2001). Figure 5.3 shows the input parameters interface of the Fragility Curve for the Dam SPN model in the FCEPN system. The location of the

resultant force and the two different factors of safety (overturning and shear-friction) were determined respectively as detailed below:

(i) Location of the resultant force: the location of the resultant force along the dam base (joint) is a performance indicator used to assess the overturning stability of the section above the crack plane that is under consideration. The location of the resultant force with respect to the upstream end of the joint is computed from FERC (1991):

$$L_{FR} = \frac{\sum M}{\sum V} \quad (5.1)$$

where  $\sum M$  = summation of moments about the upstream end of the joint (N-m/m);

$\sum V$  = summation of vertical forces including uplift pressures (N/m).

(ii) Factor of safety (overturning and shear-friction) (U.S. Department of the Interior, 1973, 1976):

$$FS_{overturning} = \frac{M_r}{M_o} \quad (5.2)$$

$$FS_{shear-friction} = \frac{CA + R_v \tan \phi}{H_h} \quad (5.3)$$

where  $M_o$  = the overturning moment (N-m/m);  $M_r$  = the resisting moment (N-m/m);  $FS_{overturning}$  = the factor of safety for overturning against the toe of the dam;  $H_h$  = the horizontal hydrostatic pressure (N/m);  $R_v$  = the vertical projection of the reaction force at the base of the dam (N/m);  $C$  = the unit cohesion (N/m<sup>2</sup>);  $A$  = the area of the contact

plane ( $m^2$ );  $\tan \phi$  = the coefficient of internal friction;  $FS_{shear-friction}$  = the factor of safety against shear stress along the contact plane.

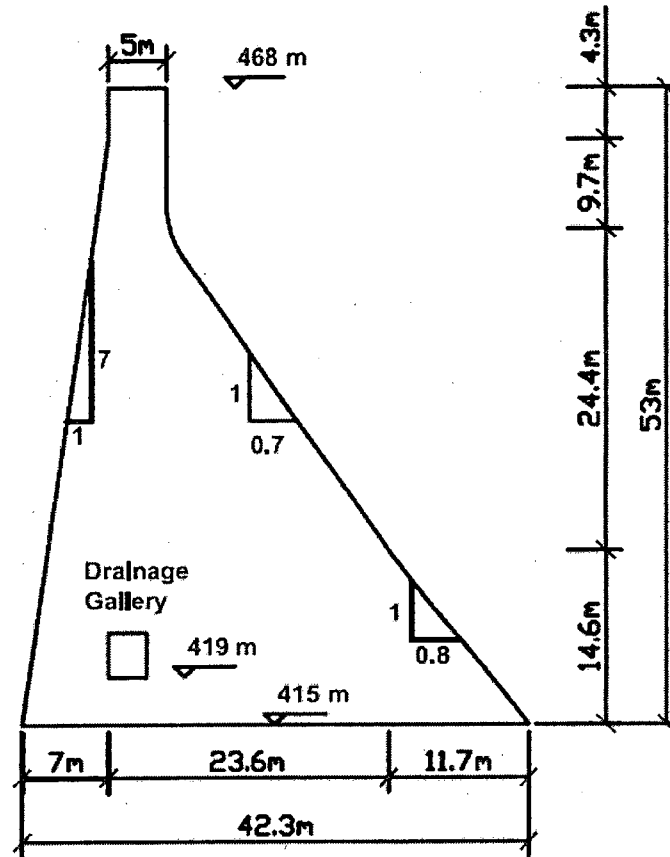

Figure 5.2: Schematic diagram of the Bluestone Dam

## 5.5 Interdependency Analysis and Vulnerability Assessment for the Dam BL Model

Physical data on the Bluestone Dam on the New River, near Hinton, West Virginia, was obtained from Ellingwood and Tekie (2001). It is a concrete gravity dam designed in the late 1930s as a combined flood-control and hydroelectric power facility. Figure 5.2 is

the schematic diagram of Bluestone Dam. The overall crest length of the dam is 629 m, consisting of 241 m of spillway and 96 m of intake structure for the power house. The maximum height of the dam is about 53 m. This data was used to construct the Dam BL infrastructure model shown schematically in Figure 5.1.

Four primary infrastructure (dam) damage states were chosen for the Fragility Curve analysis of the dam, based on historical data for the Bluestone Dam (Ellingwood and Tekie, 2001), similar to the approach taken by the U.S. Army Corps of Engineers for designing dams and the classification described by other researcher (Ellingwood and Tekie, 2001; Malla and Wieland, 1999; Shayan and Grinstead, 2006; Sultana and Chen, 2007). We defined 4 damage states for the Fragility Curve analysis as described in Methods: a) slight damage state-minor cracks (DS1), b) moderate damage state-prominent cracks (DS2), c) severe damage state-sliding failure (DS3), and d) collapsed damage state-overturning failure (DS4) (Guo and Chen, 2008).

Vulnerability assessment of the Dam BL model using Fragility Curves analysis was as outlined in the framework shown in Figure 3.1, as described in Methods. In this study, the Monte Carlo simulation is applied in the model where the random variables have been chosen as the drain effectiveness and the downstream water level, that is, 10,000 values of the both variables are generated; for the drain effectiveness parameter, the range is 0~100%, for the downstream water level, the range is 0m~12.2m. The probability of achieving four damage states for a given water level is obtained. Figure 5.4 shows the results of the analytical Fragility Curve analysis for the four damage states (DS1-DS4), based on the Dam BL model (Figure 5.1), according to different water levels.



The fragilities for DS3 and DS4 are zero for the range of water levels examined. The probability of achieving a damage state at water level 48.8 m, which was the original design water level, is very small to zero. Thus, it is likely that the dam base remains in compression at design conditions.

The screenshot shows the 'FC\_DamSPN\_Input' window with the following data:

Geometric Parameter	
b1 (m)	5
h (m)	53
s1	7
h1 (m)	4.3
s2	0.7
h2 (m)	9.7
s3	0.8
h3 (m)	24.4

Material Property	
Specific weight of dam (kN/m <sup>3</sup> )	23
Specific weight of water (kN/m <sup>3</sup> )	9.8

Water Level (m)	
Upstream water level	53

Buttons: Calculate, Close

The diagram on the right shows a dam cross-section with a top width of  $b_1$  and a total base width of  $b$ . The base is divided into segments  $b_2$ ,  $b_3$ , and  $b_4$ . The dam is divided into three vertical sections with heights  $h_1$ ,  $h_2$ , and  $h_3$ , and slopes  $s_1$ ,  $s_2$ , and  $s_3$  respectively. A small square is shown on the upstream face of the dam.

Figure 5.3: Input interface for Fragility Curve analysis of the case study in the Dam SPN model

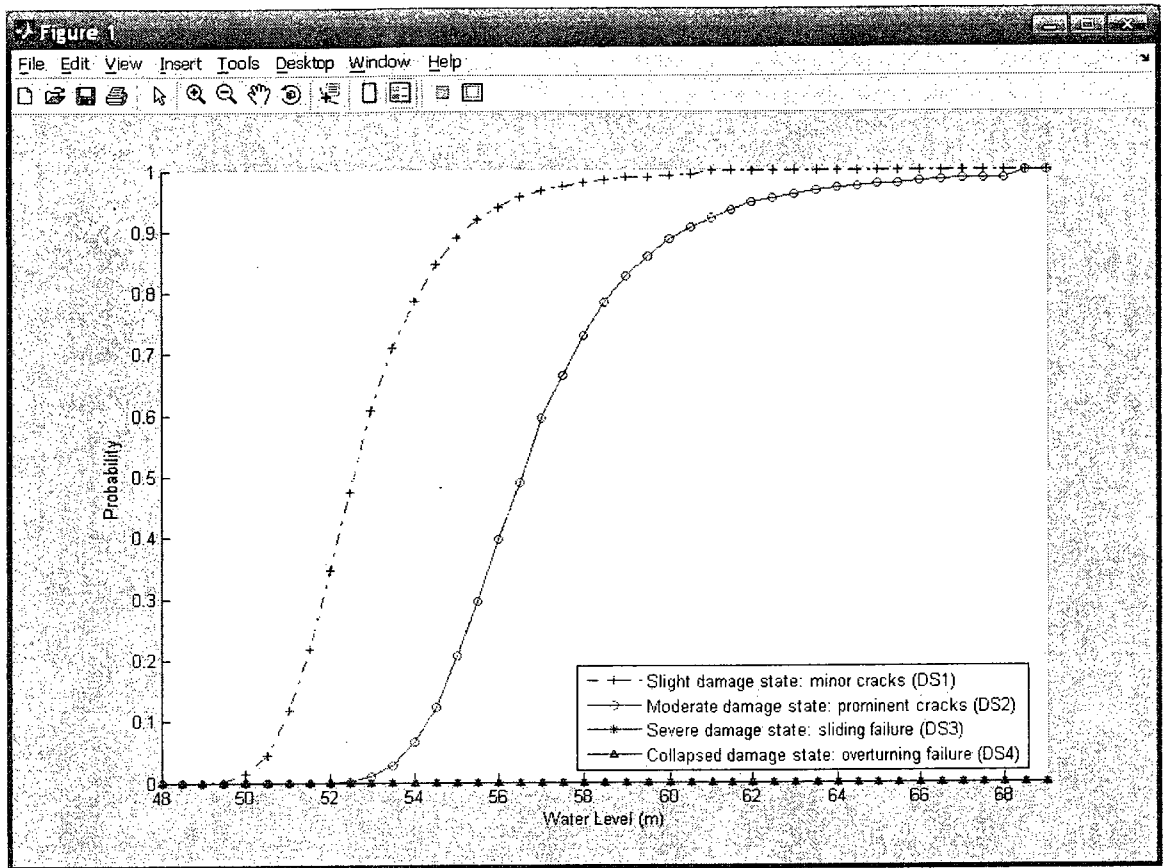

Figure 5.4: Fragility Curve analysis showing the probability of dam failure and four possible damage states (DS1-DS4) arbitrarily defined (Bluestone Dam data adapted from Ellingwood and Tekie (2001))

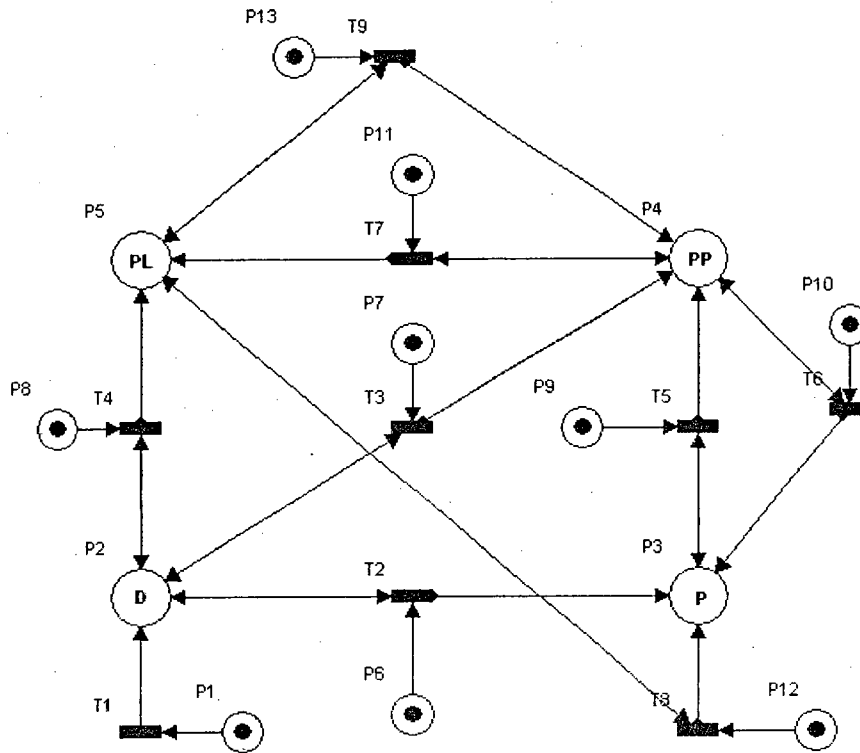

Figure 5.5: Extended Petri Net model of the flood related infrastructure components based on the Dam BL model (Figure 5.1)

For the Extended Petri Net analysis (see Figure 5.5), the network starts with a primary infrastructure (Dam) failure scenario, which is deterministic and depends on the 4 defined damage states. To simplify the interdependencies among the infrastructure system components, the network was based on the Dam BL model (Figure 5.1) and consisted of 4 components: concrete gravity dam (D), penstock (P), power plant (PP), and power lines (PL). Extended Petri Net modeling indicated thirteen Places and nine Transitions for this system (see Table 5.1 and Table 5.2, respectively). Figure 5.7 shows the input interface of the Extended Petri Net analysis for the Dam SPN model in the FCEPN system.

**Table 5.1: Thirteen places of the Extended Petri Net model (Figure 5.5) developed for the Dam BL model**

<b>Place</b>	<b>Description</b>
<b>P1</b>	<b>Dam in operation</b>
<b>P2</b>	<b>Dam failure</b>
<b>P3</b>	<b>Penstock failure</b>
<b>P4</b>	<b>Power plant failure</b>
<b>P5</b>	<b>Power lines failure</b>
<b>P6</b>	<b>Dam failure mirror (for penstock)</b>
<b>P7</b>	<b>Dam failure mirror (for power plant)</b>
<b>P8</b>	<b>Dam failure mirror (for power lines)</b>
<b>P9</b>	<b>Penstock failure mirror (for power plant)</b>
<b>P10</b>	<b>Power plant failure mirror (for penstock)</b>
<b>P11</b>	<b>Power plant failure mirror (for power lines)</b>
<b>P12</b>	<b>Power lines failure mirror (for penstock)</b>
<b>P13</b>	<b>Power lines failure mirror (for power plant)</b>

**Table 5.2: Nine transitions of the Extended Petri Net model (Figure 5.5) developed for the Dam BL model**

<b>Transition</b>	<b>Description</b>
<b>T1</b>	<b>Dam failed</b>
<b>T2</b>	<b>Dam failure affects penstock</b>
<b>T3</b>	<b>Dam failure affects power plant</b>
<b>T4</b>	<b>Dam failure affects power lines</b>
<b>T5</b>	<b>Penstock failure affects power plant</b>
<b>T6</b>	<b>Power plant failure affects penstock</b>
<b>T7</b>	<b>Power plant failure affects power lines</b>
<b>T8</b>	<b>Power lines failure affects penstock</b>
<b>T9</b>	<b>Power lines failure affects power plant</b>

Markov Chain analysis was used with the Extended Petri Net model of the Dam BL model and identified 24 different states, s1-s24, shown in Figure 5.6. The probability distributions of reaching the absorbing states (failure states) s13-s24 were calculated and the results are shown in Table 5.3. Figure 5.8 shows the results interface for the Extended Petri Net analysis in the Dam SPN model which starts at transition state s1.

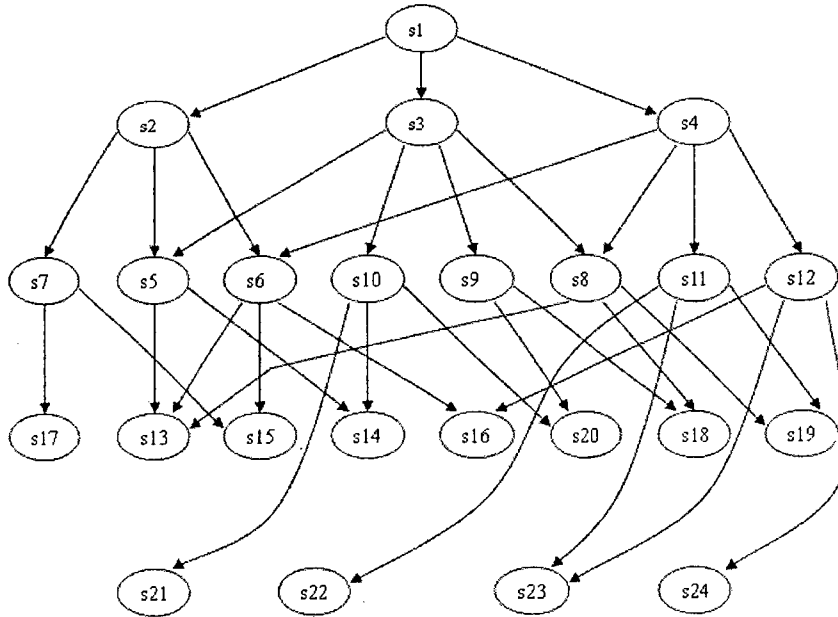

Figure 5.6: Markov Chain analysis of failure probability based on the Extended Petri Net model shown in Figure 5.5, showing 24 different states s1-s24

State Probability									
s1→s2	0.35	s3→s8	0.17	s5→s13	0.345	s8→s13	0.298	s10→s21	0.352
s1→s3	0.4	s3→s9	0.271	s5→s14	0.655	s8→s18	0.34	s11→s19	0.308
s1→s4	0.25	s3→s10	0.322	s6→s13	0.308	s8→s19	0.362	s11→s22	0.327
s2→s5	0.372	s4→s6	0.212	s6→s15	0.327	s9→s18	0.345	s11→s23	0.365
s2→s6	0.233	s4→s8	0.242	s6→s16	0.365	s9→s20	0.655	s12→s16	0.298
s2→s7	0.395	s4→s11	0.258	s7→s15	0.345	s10→s14	0.298	s12→s24	0.34
s3→s5	0.237	s4→s12	0.286	s7→s17	0.655	s10→s20	0.34	s12→s23	0.362

Figure 5.7: Input interface for the Stochastic Petri Net analysis in the Dam SPN model

**Table 5.3: Probability of reaching the Markov Chain absorbing states (failure states) s13-s24**

	s13	s14	s15	s16	s17	s18	s19	s20	s21	s22	s23	s24
s1	0.157	0.186	0.092	0.071	0.091	0.081	0.066	0.115	0.047	0.021	0.050	0.025
s2	0.200	0.244	0.213	0.085	0.259	0.000	0.000	0.000	0.000	0.000	0.000	0.000
s3	0.132	0.251	0.000	0.000	0.000	0.151	0.062	0.287	0.117	0.000	0.000	0.000
s4	0.137	0.000	0.069	0.163	0.000	0.082	0.167	0.000	0.000	0.084	0.198	0.098
s5	0.345	0.655	0.000	0.000	0.000	0.000	0.000	0.000	0.000	0.000	0.000	0.000
s6	0.308	0.000	0.327	0.365	0.000	0.000	0.000	0.000	0.000	0.000	0.000	0.000
s7	0.000	0.000	0.345	0.000	0.655	0.000	0.000	0.000	0.000	0.000	0.000	0.000
s8	0.298	0.000	0.000	0.000	0.000	0.340	0.362	0.000	0.000	0.000	0.000	0.000
s9	0.000	0.000	0.000	0.000	0.000	0.345	0.000	0.655	0.000	0.000	0.000	0.000
s10	0.000	0.298	0.000	0.000	0.000	0.000	0.000	0.340	0.362	0.000	0.000	0.000
s11	0.000	0.000	0.000	0.000	0.000	0.000	0.308	0.000	0.000	0.327	0.365	0.000
s12	0.000	0.000	0.000	0.298	0.000	0.000	0.000	0.000	0.000	0.000	0.362	0.340

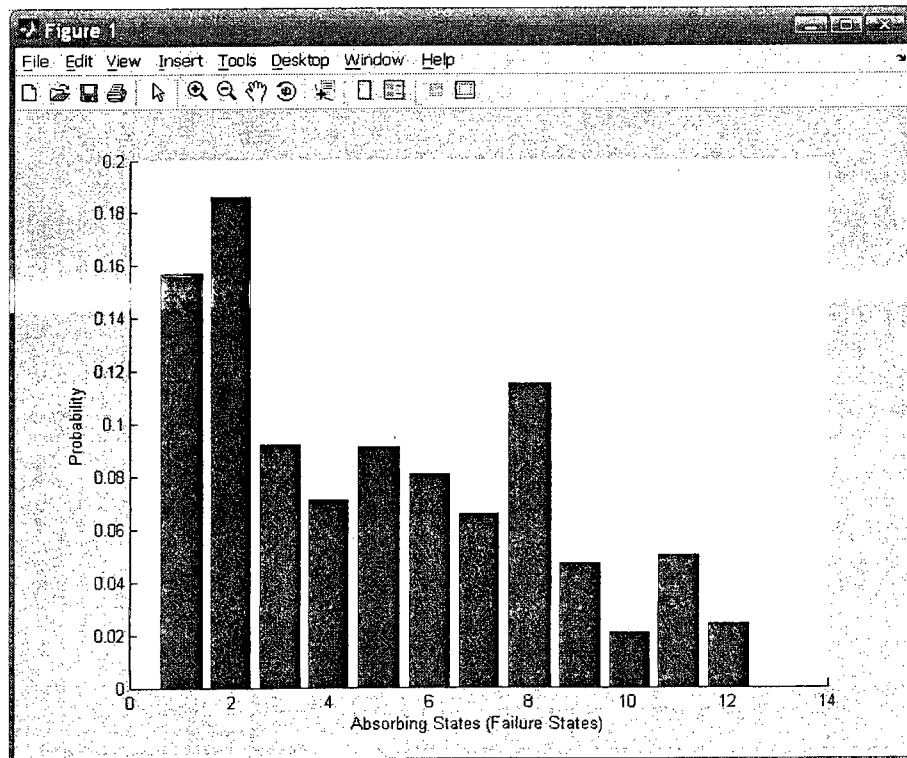

Figure 5.8: Results for Extended Petri Net analysis in the Dam SPN model

A Markov Chain is used to predict the future probability of the occurrence of an event based on the current situation and may contain the transient state and the absorbing state. The Markov Chain of the Dam BL model had 12 transient states,  $s_1$  to  $s_{12}$ , and 12 absorbing states (failure states),  $s_{13}$  to  $s_{24}$  (Figure 5.6). The probability matrix of reaching the absorbing states (failure states) is shown in Table 5.3; if the net starts at transient state 1 (dam failure occurs due to flooding), then the probability of reaching absorbing states (failure states)  $s_{13}$  to  $s_{24}$  are 0.157, 0.186, ..., 0.050 and 0.025, respectively. Similarly, if the net starts at transient state 4 (power lines fail due to flooding), the probability of reaching the same absorbing states (failure states)  $s_{13}$  to  $s_{24}$  is 0.137, 0, ..., 0.098, respectively. In the extended analysis of the Markov Chain, the derived absorbing states (failure states)  $s_{13}$  to  $s_{24}$  indicate the same condition; that is, all the components in the network fail, but the absorbing states (failure states) are attained in different ways/order. For example, state 17 is attained by firing T1, T2, T5, and T7, which means that if a penstock failure occurs because of flood inundation, it subsequently interrupts the power plant operation, finally preventing the power lines from distributing electricity. State 19 is reached by firing T1, T3, T4, and T8; in this case, the power plant and the power lines fail (due to flooding), and the penstock fails due to the blackout of power transmission from the power lines.



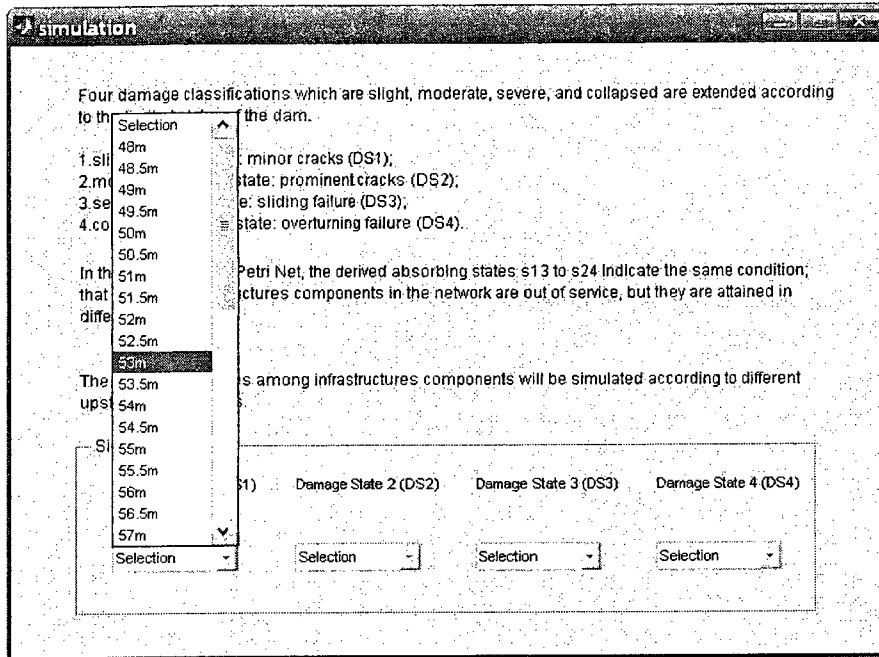

Figure 5.9: Screen shot of the GUI simulation of the Dam BL model (integrated Fragility Curve with Extended Petri Net analysis) for different water levels

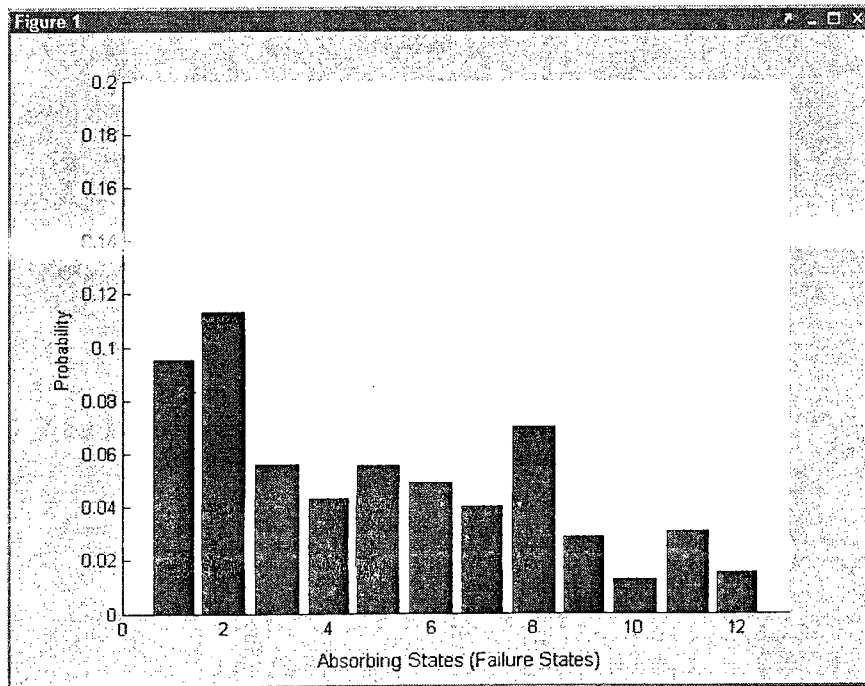

Figure 5.10: Screen shot of the results for water level of 53 m for the 12 different absorbing states (failure states) s13-s24 (see Figure 5.6)

Figure 5.9 shows a screenshot of the GUI simulation of the Dam BL model and shows possible options for infrastructures components interdependencies simulation. The user can select any water level in the pull down menu, and plot the corresponding probability distribution figure shown in Figure 5.10. For instant, for damage state 1 (DS1; slight damage), the probability distribution of the 12 different failure states at 53 m water level is shown in Figure 5.10. In this case, the absorbing state 2, that is, first, the dam is inundated by the flood, and then the flood will affect the power lines or penstock, afterwards, the power lines are interrupted, resulting in the shutdown of the power plant, has the largest failure probability.

## **5.6 Validation of the Extended Petri Net Model Using Bayesian Network Method**

In order to provide additional support for the FCEPN system described above, a Bayesian Network (BN) model was constructed to verify the Extended Petri Net model results using the same case study of the Bluestone Dam and the same derived Dam BL model. A Bayesian Network is a probabilistic graphical model that represents a set of variables and their probabilistic independencies. BNs were pioneered to solve problems in Artificial Intelligence (AI) and have proven successful in “intelligent” applications such as medical expert systems, speech recognition, and fault diagnosis. A major benefit of using BNs is that probabilistic and causal relationships among variables are represented and executed as graphs and can thus be easily visualized and extended, making model building and verification easier and faster. The power, generality, and flexibility of BNs are widely recognized and they are being successfully used in diverse

fields, including in risk analysis and decision support (Neil et al., 2005).

Bayesian Network analysis was conducted using the same case study that was used in Dam BL model, in order to confirm the Extended Petri Net analysis results. As we know, infrastructure components may not fail simultaneously in response to a major hazard. Instead, they may fail sequentially, therefore, 12 different “failure paths” for the four infrastructures components (Dam (D), Power plant (PP), Penstock (P), and Power lines (PL)) are built in Figure 5.11. In this Figure, schematic diagrams (1) to (12) correspond to the Markov Chain absorbing states (failure states) s13-s24 (see Figure 5.6). For each diagram (1) – (12), the starting point is dam failure (D, bottom left corner); the solid lines represent the subsequent sequence of events that could occur. In each diagram, all components fail, but in a different order. We define each diagram as a failure path (FP). Each diagram represents the interrelation among four infrastructures components (D, PP, P and PL). It also addresses the cascading effect for the overall infrastructure system if the dam fails. For example, in diagram (1), firstly, the dam overflows, and then this will affect the power lines, power plant, and penstock respectively, and finally the four infrastructures will fail. In diagram (2), firstly, the dam overflows, and then this will affect the power lines or penstock, and when the power lines fail, it will result in the failure of the power plant.

After determining the interdependencies of the 12 failure paths, we can input the threshold probabilities into the Bayesian Network model in order to calculate the final failure probabilities for each failure path (FP). Figure 5.12 shows the detailed calculation processes for the 12 failure paths using the Bayesian Network method. The Bayesian

Network was developed based on these 12 failure paths.

In terms of the 12 different failure paths defined above, we can obtain the failure probabilities of the system using the Bayesian Network. As shown in Figure 5.12, the highest failure probability among all of the paths shown is Path 2 (18.60%), whereas the lowest probability is Path 10 (2.11%). It is easy to determine the most dangerous path, which is the largest probability for system failure according to the Bayesian Network analysis. That is, when dam failure occurs, the most dangerous failure state is Path 2 (first the dam fails, secondly the penstock and power lines fail, and thirdly the power plant fails due to power blackout). However, the safest failure state is Path 10 (first the dam fails, secondly the power lines fail, thirdly the penstock fails, and fourthly the power plant fails due to collapse of the penstock).

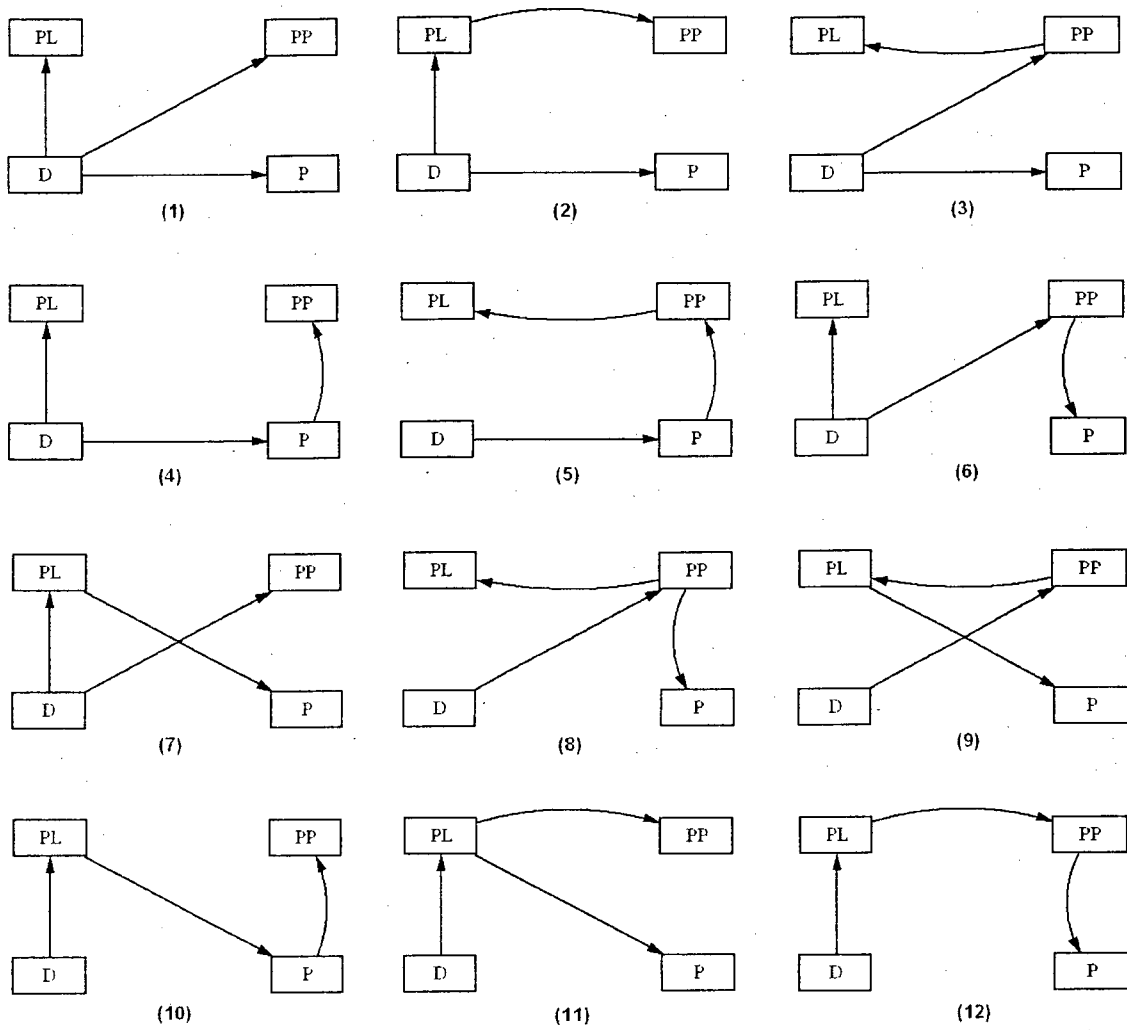
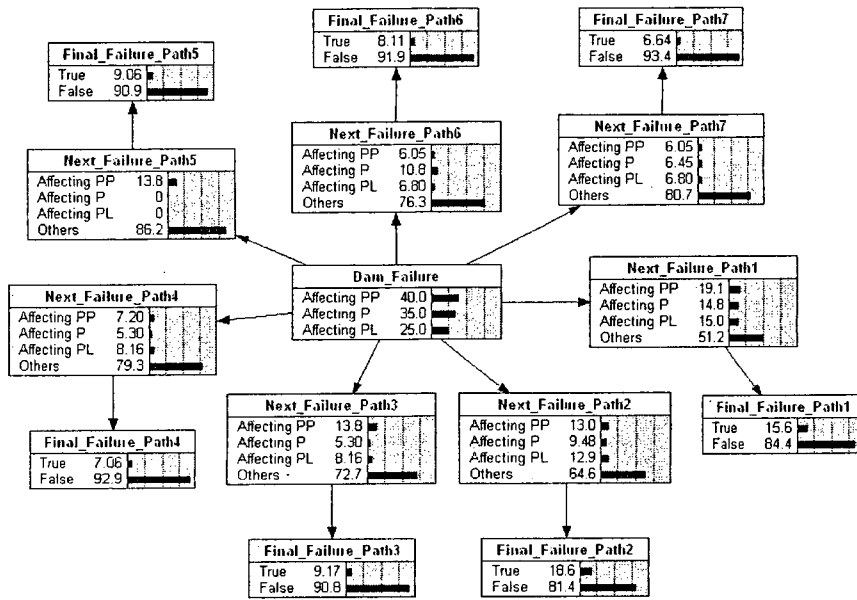
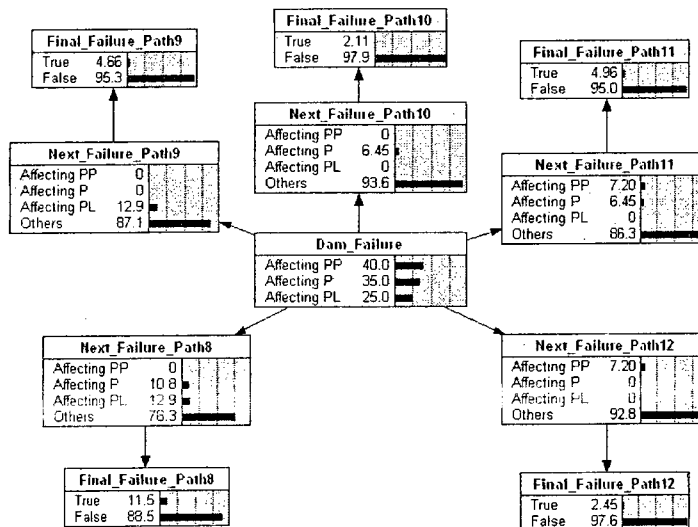

Figure 5.11: Validation of the Markov Chain analysis results for the Extended Petri Net model using the Bayesian Network method



(a)



(b)

Figure 5.12: Bayesian Network analysis results confirming the 12 failure states identified with the Markov Chain analysis (Figure 5.6). (a): failure path 1-7; (b): failure path 8-12

**Table 5.4: Comparison of the probabilities for the Bayesian Network failure paths and the Extended Petri Net absorbing states (failure states)**

Path	Path1	Path2	Path3	Path4	Path5	Path6	Path7	Path8	Path9	Path10	Path11	Path12
Probability for BN	15.60%	18.60%	9.17%	7.06%	9.06%	8.11%	6.64%	11.50%	4.66%	2.11%	4.96%	2.45%
Probability for SPN	15.70%	18.60%	9.20%	7.10%	9.10%	8.10%	6.60%	11.50%	4.70%	2.10%	5.0%	2.50%
Difference	-0.10%	0.00%	0.03%	0.04%	0.04%	0.01%	0.04%	0.00%	0.04%	0.01%	-0.04%	-0.05%

## 5.7 Discussion

The Dam BL model was used as a case study to test the FCEPN system, to simulate the interdependencies among the flood-related dam infrastructure components shown schematically in Figure 5.1. We obtained the infrastructure component interdependencies for the 12 absorbing states (failure states) at a given water level for each of the damage states (DS1~DS4) for the Dam BL model, which corresponded to the 12 “failure paths” used in Bayesian Network model. In this chapter, two different models based on two different methods (Markov Chain analysis for the Extended Petri Net and Bayesian Network) were discussed to validate the rationality and feasibility of the analysis results. Both of these were tested with the same case study and same data. Finally, we compared the Bayesian Network model results with the Markov Chain results for the Extended Petri Net model of the Dam BL model, and the results were very similar

(a comparison of the results is shown in Table 5.4). This confirms that the results of the Extended Petri Net and Bayesian Network analyses of the Dam BL model were in good agreement in terms of the probabilities/predictions of the failure states/paths for the infrastructure system.

In this thesis, Fragility Curves and Extended Petri Net analysis have been performed in combination to simulate interdependencies among flood-related infrastructures, called the FCEPN system. The Fragility Curves are generally used to analyze the vulnerability of the single infrastructure component, and the Extended Petri Net analysis aimed at determining the interdependencies of the system components or multiple interdependent infrastructures. The Fragility Curves analysis is the basis and the precondition of the FCEPN system. Multiple interdependent infrastructures are connected together into a “system of systems”, so the first step was to analyze a single infrastructure component of the system using the Fragility Curve method. This approach was then extended to evaluate the interrelations/interdependencies and the effects among the multiple infrastructures using the Extended Petri Net analysis. For instance, from the analytical Fragility Curve analysis, the probability of a minor damage state is 0.013 at 50 m water level. For the Extended Petri Net analysis, if the network starts at state 1, that is, dam failure occurs, then the probability of state 13, that is, the flood inundates the penstock, power plant and the power lines leading to the shutdown of these infrastructures is 0.157. Therefore, the overall vulnerability of the dam at 50m flood level will be  $0.013 \times 0.157 = 0.00204$ . The vulnerability of the other damage states can be determined in a similar method.



# **CHAPTER 6 CASE STUDY 2: HUAI RIVER WATERSHED AS A MULTIPLE-DAM SYSTEM CASE STUDY BASED ON THE FUZZY PETRI NET METHOD**

## **6.1 Study Area**

The Huai River watershed lays nestled in the heart of China (Figure 6.1). The watershed is located in four provinces (Henan, Jiangsu, Anhui, and Shandong) and is approximately  $27 \times 10^4$  km<sup>2</sup>. The average amount of water of the watershed is approximately  $595 \times 10^8$  m<sup>3</sup>. The watershed is composed of several rivers and lakes (Figure 6.2). The main stream of Huai River is situated between the Changjiang River and the Yellow River, it runs primarily from the west to east passing through Hongze Lake, Gaoyou Lake and Shaobo Lake into the Changjiang River. During the rainy season (June to September) the Huai River watershed receives 70% of its total annual precipitation. Therefore, the natural disasters that result from drought and flood impact greatly on human health and the urban environment.

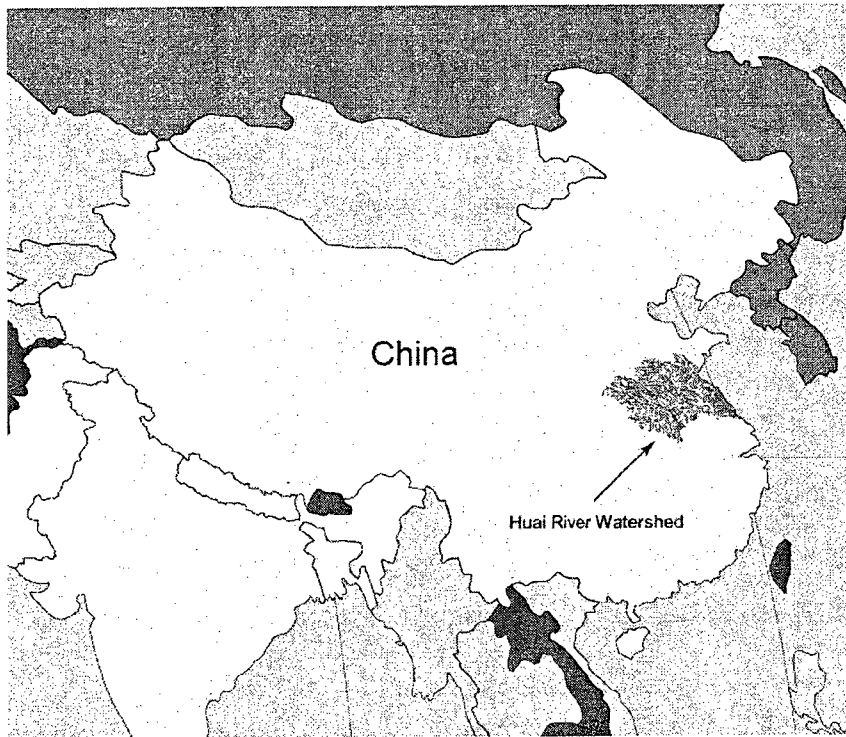

Figure 6.1: The Huai River Watershed in China

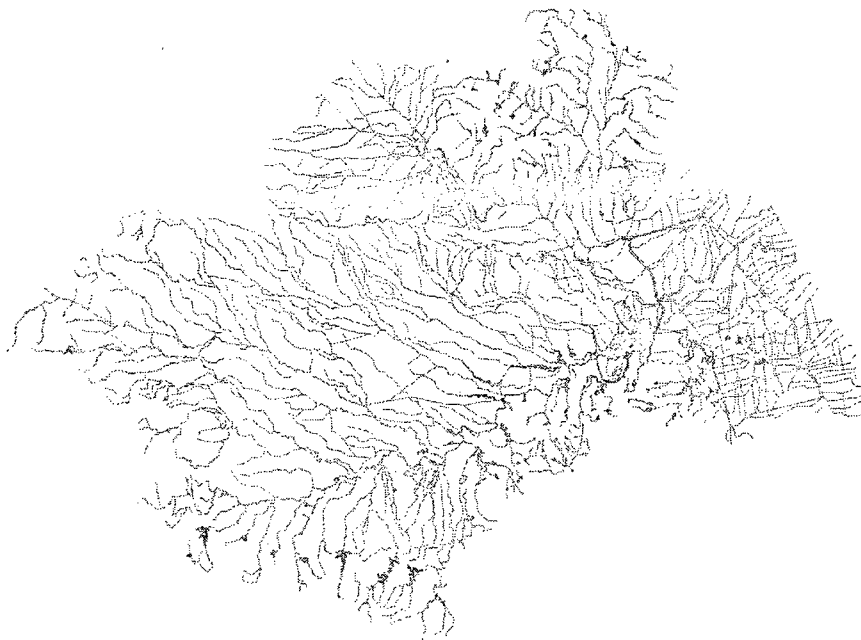

Figure 6.2: Distribution of the rivers and lakes in the Huai River watershed

There are more than 10000 dams/sluices and reservoirs in the Huai River watershed. The total capacity is approximately  $303 \times 10^8 \text{ m}^3$ . The dams and sluices are used for flood control and for storing water for various purposes, such as irrigation, power plant, municipal drinking water, etc.

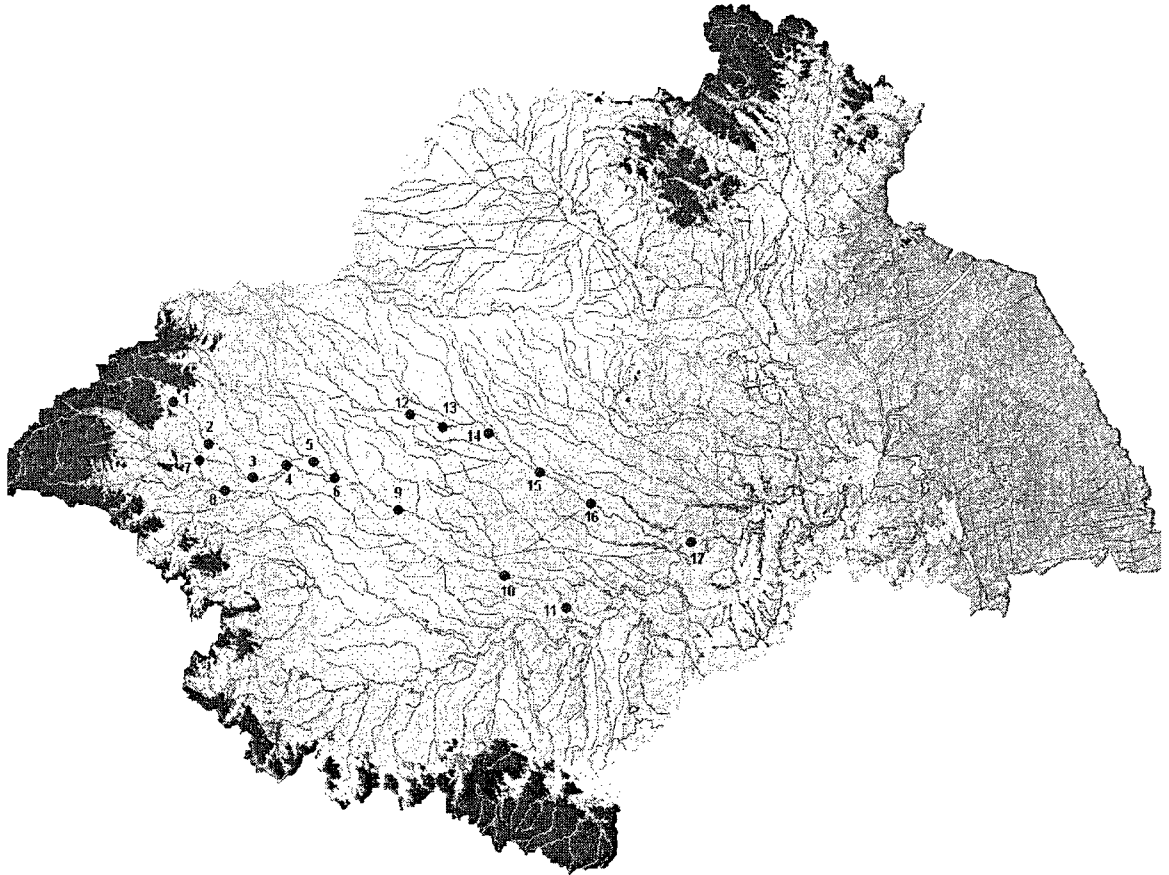

Figure 6.3: The Huai River watershed with digital elevation model (DEM) showing 17 dams/sluices

Figure 6.3 is a spatial distribution map of the Huai River watershed with digital elevation model (DEM), with the elevation indicated in different colors. The spatial distribution of the dams/sluices is shown with red points and the spatial distribution of the

rivers in the watershed is shown with blue lines. When the upstream dams/sluices overflow or collapse due to flooding, earthquake or other disasters, this may cause damage to the downstream dams/sluices due to the elevation and water system distribution. Flood impact may cause cascade and domino effects.

We choose some of dams/sluices in the Huai River watershed as a case study to assess the interdependency and vulnerability among multiple-dams/sluices system using the FCEPN system. Due to inadequate data for the watershed, we only use the Extended Petri Net model of the FCEPN system to analyze the interdependency and vulnerability among the multiple-dams/sluices system.

## **6.2 Steps of the Extended Petri Net Analysis and Risk**

### **Assessment**

The framework of the Extended Petri Net analysis and risk assessment is shown in Figure 6.4. The steps for this analysis include:

1. Map the spatial distribution of the Huai River watershed using GIS data;
2. Determine the spatial places, spatial transitions and spatial relationships of the dams/sluices in the spatial distribution map;
3. Develop the Extended Petri Net model;
4. Use the data for the capacity of each dam/sluice to calculate its capacity ratio, impact factor and relationship strength. The details are presented in the following section: Calculation of Relationship Strength;
5. Combine the relationship strength and initial state to fire the enabled transition in

the Extended Petri Net model;

6. Calculate the risk value for each dam/sluice.

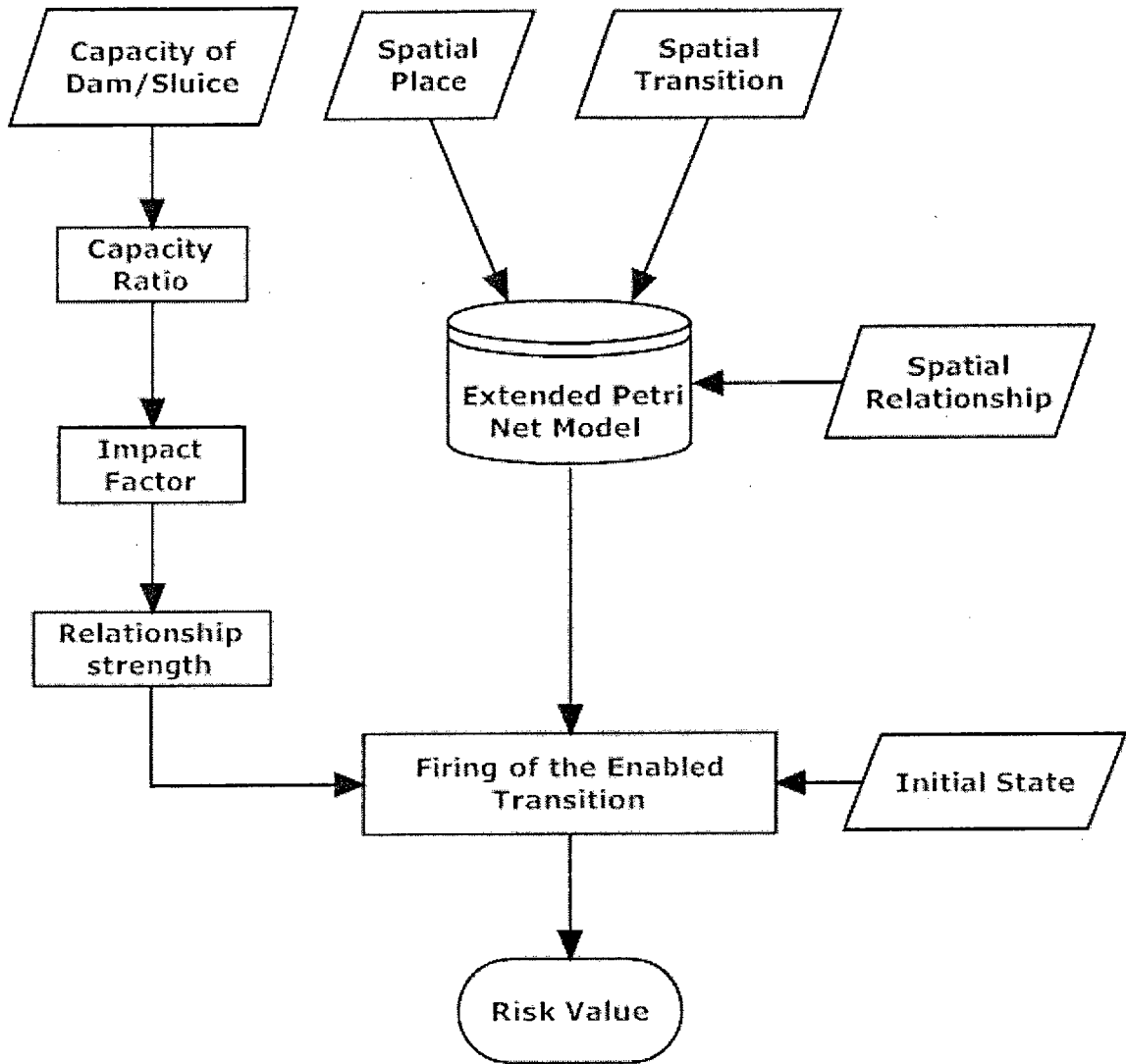

Figure 6.4: Framework for risk assessment of the Huai River watershed

### 6.3 Extended Petri Net Model

An Extended Petri Net model was developed based on the spatial distribution of the seventeen dams/sluices shown in Figure 6.3, and is shown in Figure 6.5. P1-P17

denote the places,  $t1-t16$  denote the transitions, and  $\mu_1-\mu_{16}$  denote the relationship strength, respectively. The places and transitions are listed in Table 6.1 and Table 6.2.

To model the interdependencies among the above dams/sluiques, their interactions need to be captured. Since the Huai River flows from upstream to downstream, the direction of the cascade or domino effects of the dams/ sluiques in the study area is only in one direction, that is, also from the upstream to downstream. For example, P1 affects P2 directly, whereas, P2 does not have any influence on P1. Due to the interdependency among the dams/sluiques, P1 may indirectly affect P3, P4, P5, ...P17.

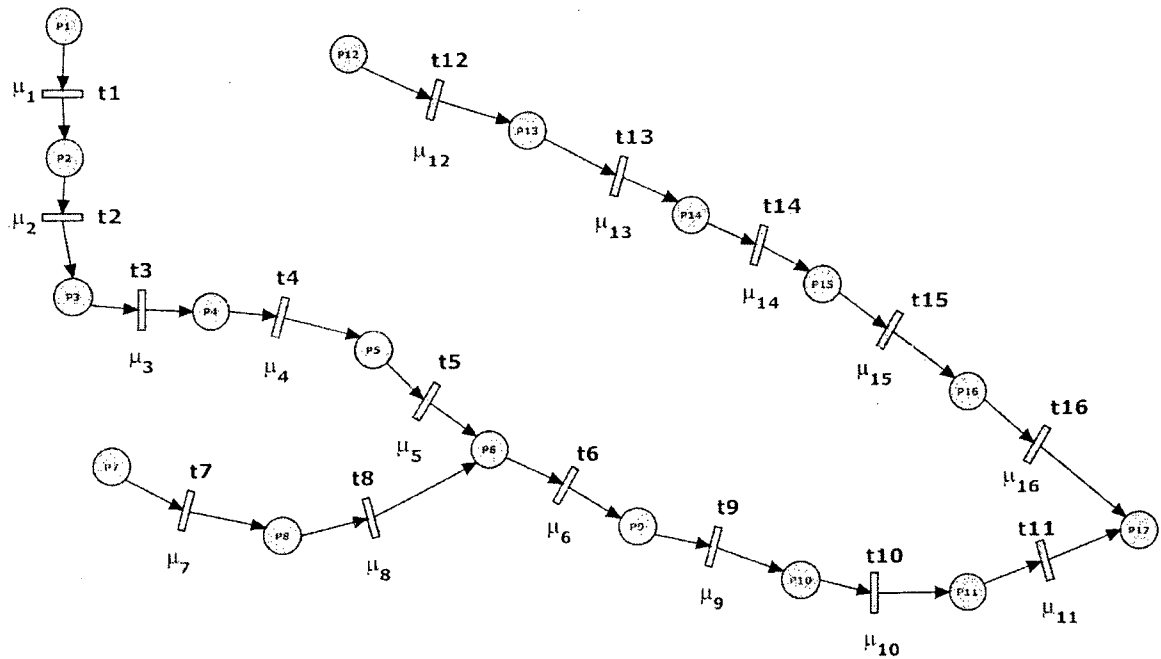

Figure 6.5: Extended Petri Net model for the dams/sluiques in the Huai River watershed

**Table 6.1: Seventeen places of the Extended Petri Net model developed for the Huai River watershed dams/sluides (shown in Figure 6.5)**

<b>Place</b>	<b>Description</b>
<b>P1</b>	<b>Beiguan Dam failure</b>
<b>P2</b>	<b>Huaxing Sluice failure</b>
<b>P3</b>	<b>Yinghe Sluice failure</b>
<b>P4</b>	<b>Luohe-Shahe Dam failure</b>
<b>P5</b>	<b>Huangqiao Sluice failure</b>
<b>P6</b>	<b>Shahe-Zhoukou Sluice failure</b>
<b>P7</b>	<b>Dachen Sluice failure</b>
<b>P8</b>	<b>Mawan Sluice failure</b>
<b>P9</b>	<b>Huaidian Sluice failure</b>
<b>P10</b>	<b>Fuyang Sluice failure</b>
<b>P11</b>	<b>Yingshang Sluice failure</b>
<b>P12</b>	<b>Xuanwu Sluice failure</b>
<b>P13</b>	<b>Fuqiao Sluice failure</b>
<b>P14</b>	<b>Dashi Sluice failure</b>
<b>P15</b>	<b>Woyang Sluice failure</b>
<b>P16</b>	<b>Mengcheng Sluice failure</b>
<b>P17</b>	<b>Bengbu Sluice failure</b>

**Table 6.2: Sixteen transitions of the Extended Petri Net model developed for the Huai River watershed dams/sluides (shown in Figure 6.5)**

<b>Transition</b>	<b>Description</b>
<b>t1</b>	<b>Beiguan Dam failure affects Huaxing Sluice</b>
<b>t2</b>	<b>Huaxing Sluice failure affects Yinghe Sluice</b>
<b>t3</b>	<b>Yinghe Sluice failure affects Luohe-Shahe Dam</b>
<b>t4</b>	<b>Luohe-Shahe Dam failure affects Huangqiao Sluice</b>
<b>t5</b>	<b>Huangqiao Sluice failure affects Shahe-Zhoukou Sluice</b>
<b>t6</b>	<b>Shahe-Zhoukou Sluice failure affects Huaidian Sluice</b>
<b>t7</b>	<b>Dachen Sluice failure affects Mawan Sluice</b>
<b>t8</b>	<b>Mawan Sluice failure affects Shahe-Zhoukou Sluice</b>
<b>t9</b>	<b>Huaidian Sluice failure affects Fuyang Sluice</b>
<b>t10</b>	<b>Fuyang Sluice failure affects Yingshang Sluice</b>
<b>t11</b>	<b>Yingshang Sluice failure affects Bengbu Sluice</b>
<b>t12</b>	<b>Xuanwu Sluice failure affects Fuqiao Sluice</b>
<b>t13</b>	<b>Fuqiao Sluice failure affects Dashi Sluice</b>
<b>t14</b>	<b>Dashi Sluice failure affects Woyang Sluice</b>
<b>t15</b>	<b>Woyang Sluice failure affects Mengcheng Sluice</b>
<b>t16</b>	<b>Mengcheng Sluice failure affects Bengbu Sluice</b>

## **6.4 Calculation of Relationship Strength**

Relationship strength is used to quantify the relationship between two spatial objects. For different spatial objects, the calculation of Relationship strength may become different. In this case study, in order to determine the Relationship strength between two



dams/sluices, we need to consider many factors, such as their spatial distribution, water flow direction, capacity, and risk value, etc. Finally, we can determine the relationship strength by Equation (6.1), (6.2), and (6.3). The result of the relationship strength calculations are shown in Table 6.4. Here, we assume that the possibility of collapse of each dam/sluice is 50%. The capacities of all dams/sluices are shown in Table 6.3. Figure 6.6 is the input interface for this case study using the Dam FPN model in the FCEPN system.

Capacity ratio :

$$(r) = \frac{V_A}{V_B} \quad (6.1)$$

Impact factor :

$$(w) = \begin{cases} 1, & \text{if } r > 1 \\ r, & \text{if } r \leq 1 \end{cases} \quad (6.2)$$

Relationship strength :

$$(u) = (1 - P_B^-) \times w \quad (6.3)$$

where,  $V_A, V_B$  is the capacity of the dam/sluice

$P_B^-$  is the possibility of collapse of the dam/sluiice

**Table 6.3: Reservoir capacities of the dams/sluiices in the Huai River watershed**

No.	Dam/sluiice	Capacity ( $10^4.m^3$ )
1	Beiguan Dam	483
2	Huaxing Sluice	397
3	Yinghe Sluice	2230
4	Luohe-Shahe Dam	602
5	Huangqiao Sluice	1800
6	Shahe-Zhoukou Sluice	4780
7	Dachen Sluice	1737
8	Mawan Sluice	1100
9	Huaidian Sluice	4220
10	Fuyang Sluice	10640
11	Yingshang Sluice	8300
12	Xuanwu Sluice	990
13	Fuqiao Sluice	365
14	Dashi Sluice	10680
15	Woyang Sluice	5500
16	Mengcheng Sluice	6130
17	Bengbu Sluice	68500

FPN\_DamFPN\_Input

Capacity (10000*m3)		Possibility of Collapse	
P1	483	P10	10640
P2	397	P11	8300
P3	2230	P12	990
P4	602	P13	365
P5	1800	P14	10680
P6	4780	P15	5500
P7	1737	P16	6130
P8	1100	P17	68500
P9	4220		
		P1	0.5
		P2	0.5
		P3	0.5
		P4	0.5
		P5	0.5
		P6	0.5
		P7	0.5
		P8	0.5
		P9	0.5
		P10	0.5
		P11	0.5
		P12	0.5
		P13	0.5
		P14	0.5
		P15	0.5
		P16	0.5
		P17	0.5

Calculate Close

Figure 6.6: Input interface for the Huai River case study using the Dam FPN model

**Table 6.4: Matrix showing the results of the relationship strength calculations for the 17 dams/sluices of the Huai River watershed (based on Equations 6.1, 6.2, 6.3)**

	P1	P2	P3	P4	P5	P6	P7	P8	P9	P10	P11	P12	P13	P14	P15	P16	P17	
P1	1.0000	0.500	0	0	0	0	0	0	0	0	0	0	0	0	0	0	0	
P2	0	1.0000	0.089	0	0	0	0	0	0	0	0	0	0	0	0	0	0	
P3	0	0	1.0000	0.500	0	0	0	0	0	0	0	0	0	0	0	0	0	
P4	0	0	0	1.0000	0.167	0	0	0	0	0	0	0	0	0	0	0	0	
P5	0	0	0	0	1.0000	0.188	0	0	0	0	0	0	0	0	0	0	0	
P6	0	0	0	0	0	1.000	0	0	0.500	0	0	0	0	0	0	0	0	
P7	0	0	0	0	0	0	1.0000	0.500	0	0	0	0	0	0	0	0	0	
P8	0	0	0	0	0	0.115	0	1.000	0	0	0	0	0	0	0	0	0	
P9	0	0	0	0	0	0	0	0	1.0000	0.198	0	0	0	0	0	0	0	
P10	0	0	0	0	0	0	0	0	0	1.0000	0.500	0	0	0	0	0	0	
P11	0	0	0	0	0	0	0	0	0	0	1.000	0	0	0	0	0	0.060	
P12	0	0	0	0	0	0	0	0	0	0	0	1.0000	0.500	0	0	0	0	
P13	0	0	0	0	0	0	0	0	0	0	0	0	1.0000	0.017	0	0	0	
P14	0	0	0	0	0	0	0	0	0	0	0	0	0	1.0000	0.500	0	0	
P15	0	0	0	0	0	0	0	0	0	0	0	0	0	0	1.0000	0.449	0	
P16	0	0	0	0	0	0	0	0	0	0	0	0	0	0	0	1.0000	0.045	
P17	0	0	0	0	0	0	0	0	0	0	0	0	0	0	0	0	0	1.000

**Table 6.5: The results of the Probability risk calculations for the 17 dams/slucies in the Huai River watershed**

P1	P2	P3	P4	P5	P6	P7	P8	P9	P10	P11	P12	P13	P14	P15	P16	P17
0.500	0.750	0.567	0.784	0.631	0.619	0.500	0.750	0.810	0.660	0.830	0.500	0.750	0.513	0.757	0.840	0.550

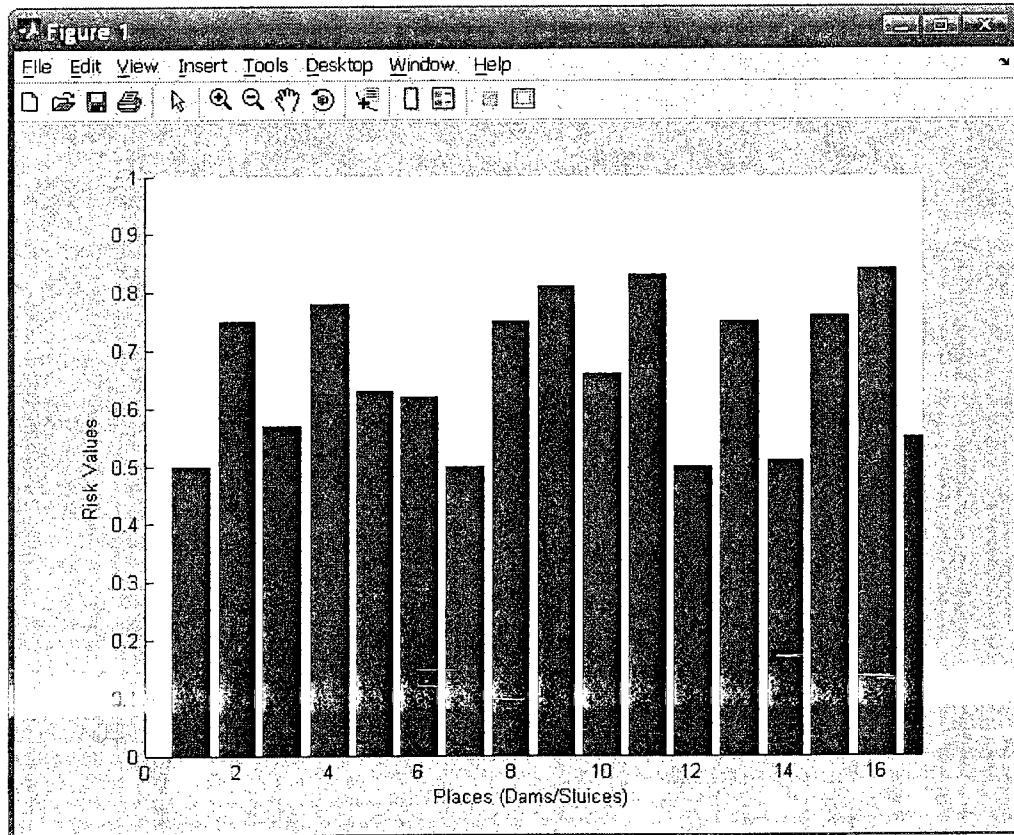

Figure 6.7: Analysis result for the Huai River case study using the Dam FPN model

## 6.5 Results Analysis

To some extent, we can indicate the most dangerous dam/slucie due to flooding by the probability risk value of the dam/slucie. In terms of the result of the relationship

strength calculations and the Extended Petri Net model, we can obtain the probability risk value of the dam/sluice using the Dam FPN model (in Table 6.5 and Figure 6.7). In Table 6.5, P4, P9, P11, and P16 have the highest risk values, which mean that when the upstream dams/sluices are collapsed, P4, P9, P11, and P16 will be the most dangerous dams/sluices in the study system. Therefore, during the rainy season, we should pay more attention to these four dams/sluices and arrange a special monitoring & regulating plan in order to prevent or mitigate the impact of damage caused by the cascade and domino effects. From Table 6.5, we also can clearly see that P3, P14, P17 have the lowest risk values.

The probability risk value of P4 is higher because the capacity of P3 ( $2230 \times 10^4 \text{ m}^3$ ) is far larger than that of P4 ( $602 \times 10^4 \text{ m}^3$ ), that is, P3 has a dominating influence on P4. The probability risk value of P9 results from the combined influences of P1-P8. In the same way, the combined influence of P1-P10 affects the probability risk value of P11; and the combined influence of P12-P15 affects the probability risk value of P16.

Because the capacity of P2 ( $397 \times 10^4 \text{ m}^3$ ) is far less than that of P3 ( $2230 \times 10^4 \text{ m}^3$ ), P2 has less of an influence on the probability risk value of P3. Similarly, the capacity of P13 ( $365 \times 10^4 \text{ m}^3$ ) is also far less than that of P14 ( $10680 \times 10^4 \text{ m}^3$ ), so the probability risk value of P14 is also lower. As for P17, it is affected by the combination of P1-P16, so the probability risk value should be very high, however, the simulation result is lower, and this is because the capacity of P17 is very large ( $68500 \times 10^4 \text{ m}^3$ ). In addition, the probability risk value of P6 is not very high even if P6 is affected by the combination of P1-P8. The primary reason is that the capacities of P1-P8 are lower compared with the

capacities of the other dams/sluices.

Based on the above discussion, the simulated results appear to accurately represent the interdependency and vulnerability of the case study dams/sluices due to the cascade or domino effects.

## 6.6 Discussion

As shown in the Huai River watershed case study, when two dams exist in close proximity to each other, failure of one dam can impact the other dam, and failure of both dams can cause a combined flood event of greater magnitude downstream than would result if either of the dams failed by itself. There are other cases where two dams are located along the same river with one dam directly downstream of the other dam, or where two dams are located on tributaries that combine into a common river downstream. Thus, capturing the interrelationships between dams in a multiple-dam system is an important research area due to their cascading or domino effects. In this chapter, all the above mentioned interdependencies among the dams/sluices are addressed by the Dam FPN model of the FCEPN system in the China Huai River watershed case study.

The Dam FPN model of the FCEPN system is based on a Fuzzy Petri Net (FPN) model described in Chen et al. (1990). The FPN formalism is a derivative of PNs which have been demonstrated to be powerful modeling formalisms. Major features of FPNs include: reasoning for uncertain and imprecise information, knowledge representation, reasoning mechanisms, and explanation of reasoning processes. Thus, The Dam FPN model offers several important benefits: First, a complex system reasoning path can be

reduced to a simple sprouting tree mentioned in Chen et al. (1990), when the fuzzy reasoning algorithm is applied. Second, the major features offered by the Petri Net model can also be applied to our model. Third, this model is suitable for implementing systems based on forward chaining inference methodology. Fourth, it can deal with different types of composite fuzzy rules. Fifth, it deals with the threshold value assigned to the antecedent parts of fuzzy rules. The original article of Chen et al. (1990) assigns a single value to all production rules in the system, whereas the Dam FPN model assigns a value to each rule. In addition, the Dam FPN model can assign a distinct threshold value to each proposition in the antecedent parts of a composite fuzzy rule. Sixth, it can be used to analyze multiple-dam system and combines the possibility analysis of dams by Fragility Curve analysis and fuzzy reasoning into a hybrid approach to deal with uncertain and imprecise information. This can assist in the assessment of multiple-dam system and gives a more effective decision space for management.

However, a number of significant shortcomings of the proposed Dam FPN model have been identified. The first is that large reachability sets and adjacent places and transitions tables may result when applying this model to represent a large complex system. The second one is the undesirable effect that no conclusion can be reached when applying this model to a large complex system as the number of places and transitions in the Fuzzy Petri Net model increases, because the conclusion after many multiplications may become very small.



## CHAPTER 7 DISCUSSION

The economic costs of extreme weather and flood catastrophes that occur globally are significant. Flooding is one of the leading causes of loss of life and property. Half of all losses caused by natural phenomena are usually attributed to flooding. In a recent 10-year period (1991 to 2000), losses caused by flooding in the world have mounted to more than \$250 billion (Kron, 2000). Additionally, the number of major flood disasters has risen significantly in recent times. There were six in the 1950s; seven in the 1960s; eight in 1970s; eighteen in the 1980s; and twenty six in the 1990s (Collins, 2007). The most important infrastructure for preventing flooding is the dam. However, once a dam fails, it becomes a national catastrophe! This happens with fearful rapidity, and usually with little warning. Moreover, it can rapidly generate a cascading or domino effect affecting other related infrastructures. For example, the St. Francis Dam, a curved concrete gravity structure 209 feet high, located in the mountains about 35 miles north of downtown Los Angeles, failed catastrophically near midnight just before March 12, 1928. The failure released 36,180 acre-feet of water down the San Francisquito Canyon on a turbulent 55-mile journey to the Pacific Ocean near Ventura, killing 450 people. As the deadliest American civil engineering failure of the 20<sup>th</sup> century, the city of Los Angeles paid more than \$7 million in restitution to the victims' families and affected landowners. Therefore, this is why we have focussed on the interdependency and vulnerability analysis of dam infrastructure systems, especially for the dams analyzed in this thesis study.

The FCEPN system is based on two analysis method and provides a more comprehensive framework for analyzing infrastructure interdependency related problems

than using either method alone. The FCEPN system described here includes modeling of critical infrastructures based on historical databases, defining damage states, and integrating Fragility Curve and Extended Petri Net analyses to arrive at useful predictions of system component failure states. A user-friendly GUI for the FCEPN system was developed as a useful decision tool to facilitate the application. Then, using the GUI system that was developed, the FCEPN system was applied to a simplified example of a hydraulic dam infrastructure system (based on the Bluestone Dam, West Virginia), consisting of four components (dam, penstock, power plant, power lines), and predicted the most likely system failure state. Similarly, using the GUI system, the FCEPN system was applied to another case study, of a multiple-dam system (based on the Huai River watershed, China), and the probability risk values were determined for the multiple-dam system. The FCEPN system could be extended for use with other infrastructure systems (such as bridges, power plants, geothermal plants, windmill farms, etc.) and could work with more complex infrastructure systems having many components or multiple infrastructures. Therefore, the FCEPN system could help to develop a more efficient emergency management strategy and to effectively simulate risk management in various fields.

The FCEPN system was used in this thesis in order to analyze and quantify the system component interdependencies and the cascading impact of a flood (high water levels) on the components. Flood hazards not only impact one single infrastructure, but also affect multiple interconnected infrastructures, which become vulnerable due to their high degree of interconnectedness with the initially damaged infrastructure. The proposed infrastructure interdependency modeling approach (FCEPN) was applied to two case

studies to demonstrate the cascading impact of flooding on the dam infrastructures. The dependencies among infrastructures were first mapped using Extended Petri Net analysis; the analysis of the generated network was then used to quantify the interdependencies among the interconnected infrastructures.

As the core module of FCEPN system, Extended Petri Nets are an excellent tool for modeling systems with interacting concurrent components. The fundamental idea behind this type of modeling is the composition of systems with separate interacting components. Each component has its own functional state, and this state may change over time via interactions. Furthermore, as a modeling technique, the Extended Petri Net has the following advantages:

- Flexible: There are a wide range of Petri Net extensions to suit different needs. For example, Fuzzy and Stochastic Petri Net are suitable for performance analysis;
- Adaptable: Since Extended Petri Nets are based on very few abstract ideas, they are easily adaptable to a variety of modeling domains;
- Visual: Extended Petri Nets utilizes a graphical modeling notation, making them easy to understand and work with;
- Analytical: Extended Petri Nets support formal mathematical analysis of operational properties.

The quality and availability of the input data influences the outputs of the system that was developed. The selection of input parameters also has significant effects on the outputs of the system. The following section discusses some assumptions and

simplifications of the input parameters in the two case studies. Further validation and studies should be performed.

- 1) For the Fragility Curve analysis, the seismic effect for the dam was not considered in the case study; more variable parameters for the dam should be considered in order to find the most sensitive parameters for the dam analysis.
- 2) In the Bluestone Dam case study, the transition rate of the Extended Petri Net model is assumed due to lack of historical data; more interconnected infrastructures or components should be added in the Extended Petri Net model, in order to better accommodate real applications.
- 3) In the Huai River case study, the possibility of collapse of the dams/sluiques was assumed as 50% because of lack of data for the dams/sluiques. If there was more data for the dams/sluiques, the possibility of collapse for each dam/sluique at any water level could be determined by the Fragility Curve analysis. Moreover, the transition rules for the Extended Petri Net are simplified in this case, for example, dam A failure affects dam B. The transition rules could have been more complicated and definitions more quantified if the detailed data for the multiple-dams/sluiques system had been available.

# CHAPTER 8 CONCLUSIONS

## 8.1 Summary of the Research

In the present research, the FCEPN system was developed for infrastructure risk assessment and interdependency analysis, which integrates Fragility Curve analysis with Extended Petri Net analysis. A case study of the Bluestone Dam (West Virginia) was used to develop a model of a complex critical infrastructure system with four components (Dam BL model) in order to evaluate the FCEPN system. In this model, the dam was the primary component and thus the first component that failed in each failure state. The penstock, power plant, and power lines were considered as the secondary infrastructure components with different levels of interdependencies. A user-friendly graphical user interface (GUI) was developed for the Dam BL model that integrates the Fragility Curve and Extended Petri Net approaches, to facilitate technology transfer and to provide significant help for the processing of model input data and output results.

Using the FCEPN system, we developed the Extended Petri Net model to simulate the interdependency and risk for the spatial object (dam/slucice) in the Huai River watershed. In the Extended Petri Net model, the calculation of the relationship strength and the definition of the transition depend on the purpose of the research, the relationship of the spatial objects and the information/data available for the project. In this case study, although some assumptions and simplifications were used in the model, the simulated results still accurately represented the interdependencies and the risks of the dams/slucices in the watershed. Therefore, FCEPN system analysis can provide reasonable and effective support for management and safety decisions regarding each dam/slucice. In

the future, if we have more adequate data for the dams/sluiques in the watershed, we can obtain more accurate results and provide more further simulation and analysis for the practical problems that occur in Huai River watershed.

The FCEPN system was successfully used to predict the most important failure states, the most vulnerable infrastructures and the interdependency among the infrastructures in the Bluestone Dam case study and the Huai River case study. We suggest that the FCEPN system may provide a useful tool for assessment of flood impact on critical dam infrastructure system and for predicting the vulnerability of infrastructure system damage states and the complicated interdependency of system components. This type of risk assessment and interdependency analysis can be used to assess the performance and reliability of existing infrastructures, to identify significant design and inspection parameters, and to support planning of facility maintenance and inspection (by providing supporting data for setting up the type and frequency of inspections). Based on this FCEPN system, comparisons can be made regarding where to target investments and which improvement options are most efficient in reducing the risk, assuming an equal investment. All of these could help decision makers to develop more efficient emergency management plans for various commonly occurring disasters.

## **8.2 Contributions of the Research**

Based on the above mentioned study, the research contributions of this present thesis are summarized as follows:

- 1) Direct or indirect interdependencies among infrastructure elements are complex.

Understanding cascading effects among infrastructure elements is quite important and necessary for effective responses and management of resources for rescue, recovery, and restoration in an emergency or disaster. Because of direct and indirect interrelationships among elements, the effect may propagate from one element to others until it is too small to influence others. This is the so-called cascading process. Unexpected serious accidents among infrastructure elements may have regional, national, and even international consequences because of the potential cascading process across infrastructures. In this thesis, we developed a network-based system (FCEPN) with a new user-friendly GUI to demonstrate the above mentioned direct or indirect interdependencies among infrastructure elements in complex systems.

- 2) The system (FCEPN) that was developed has been systematically evaluated and validated, showing that the FCEPN system can successfully be used to provide risk assessment of infrastructures and to analyze the complex interdependency among related infrastructure systems or components. Therefore, it is valuable tool to enhance mitigation and preparedness management for both single infrastructures and multi-infrastructure systems.
- 3) The Extended Petri Net model is a dynamic tool that is useful for evaluating the safety of the components in a system. Previously, this methodology has been applied for predicting software performance and has never been used or introduced for possible applications in infrastructure interdependency analysis. The present study introduced and applied the EPN methodology for addressing infrastructure interdependency and for carrying out a dynamic analysis for

quantitative assessment of infrastructure risk probabilities.

- 4) This study presents the integration of different modeling tools, namely Fragility Curves analysis, basic and Extended Petri Nets, Markov Chain and Bayesian Network methods, in order to simulate the overall vulnerability of interconnected infrastructures.
- 5) The research system developed in this study can be used to analyze the performance of existing infrastructures or to evaluate the performance of planned infrastructures. The information from the results provide greater insight about “weak paths” in the system, and increase our understanding of which infrastructure components need to be highly reliable to potentially increase overall system reliability. Managers of infrastructure systems will be able to assess the vulnerability of their own system. By analyzing the infrastructure interactions of the systems, mitigation and preparedness strategies can be formulated and evaluated for their ability to minimize the occurrence of catastrophic disruption and thus help to reduce their effects on society.

### **8.3 Future Research**

This section highlights the scope of future work which may be conducted on the basis of the work presented here.

- 1) Some improvements can be made to the FCEPN system. Fragility analysis of more infrastructure systems can be performed. The analysis should be carried out by infrastructure-specific researchers. For example, a hydraulic engineer can assess the fragility of a hydraulic dam, a bridge engineer can do this for a bridge,



and a building engineer can deal with the fragility of the structural buildings, and so on. In Extended Petri Net modeling, inclusion of the recovery strategy will make the system analysis more realistic. More critical infrastructures can be included in the study system. More complex and accurate definitions of the transition rules can be presented based on data collected widely from diverse sources.

- 2) Sensitivity analysis is the analysis of the effect of small variations in system parameters on the output measures and can be studied by computing the derivatives of the output measures with respect to the parameter. If a small change in a parameter results in relatively large change in the outcome, the outcome is said to be sensitive to that parameter. System optimization is an important application of sensitivity analysis. In the FCEPN system, both the Fragility Curve and Extended Petri Net allow the computation of the sensitivities of various parameters, such as drainage effect for the dam; arbitrary changes in the initial marking, the initial number of tokens in a place or a parameter involved in the definition of the rate or probability of one or more transitions. Carrying out sensitivity analysis of the system under study/development can identify the components that are most likely to fail and thereby make the system less susceptible to critical failures. Thus, the system manager can make more informed decisions as to inherently reliable and safe choices and/or make economic/cost tradeoffs.
- 3) The main objective of the present study was to model and analyze infrastructure interdependencies in order to give decision-makers the capability of formulating

effective risk management strategies. The framework presented in this research will enable decision-makers to understand and measure the direct and indirect impact of disruption/failure of a major infrastructure. The next endeavor would be to provide a set of tools to help evaluate the efficacy of different risk management options in order to manage the allocation of limited resources.

- 4) The last area of future research would be the integration of the FCEPN system into a complete decision support system. The GIS provides an excellent method to add, remove or change components in any of the systems and their attributes, and to manage data moving to and from the database. It would be useful if the operator were able to run the solver from the GIS. A great deal of information can be displayed using the GIS when studying a single or complex infrastructure system.

## REFERENCES

- Aalst, W. V. D., Hee, K. V., 2002. Workflow management: models, methods, and systems. MIT Press, Cambridge, MA.
- Adamou, M., Bourljault, A., Zerhouni, S., 1993. Modelling and control of flexible manufacturing assembly systems using object oriented Petri Nets. Proceedings IEEE International Workshop on Emerging Technology and Factory Automation, Palm-Cove, Cairns, Australia, 164-168.
- Agerwala, T., 1979. Putting Petri Nets to work. IEEE Computer, 12(12), 85-94.
- Amar, S., Craye, E., Gentina, J. C., 1992. A method for hierarchical specification and prototyping of flexible manufacturing systems. Proceedings IEEE Workshop on Emerging Technology and Factory Automation, Melbourne, Australia, 44-59.
- American Lifelines Alliance, 2001. Seismic fragility formulations for water systems. ASCE, Reston, VA.
- Amin, M., 2000. Toward secure and resilient interdependent infrastructures. Journal of Infrastructure Systems, 8, 67-75.
- Anagnos, T., 1999. Development of an electrical substation equipment performance database for evaluation of equipment fragilities, San Jose State University, San Jose.
- Ashon, S. I., 1995. Petri Net models of fuzzy neural networks. IEEE Transactions on System, Man, and Cybernetics, 25, 926-932.
- ATC-13, 1985. Earthquake damage evaluation data for California. ATC-13, Applied Technology Council, Redwood City, CA.
- Balbo, G., 2001. Introduction to Stochastic Petri Nets. LNCS, 2090, 84-155, Springer-Verlag, Berlin.

- Basoz, N., Kiremidjian, A. S., King, S. A., Law, K. H., 1999. Statistical analysis of bridge damage data from the 1994 Northridge, CA, Earthquake. *Earthquake Spectra*, 15(1), 25-54.
- Bastide, R. Silbertin-Blanc, C., 1991. Modelling of flexible manufacturing system by means of cooperative objects. *Computer Applications in Production and Engineering*. G. Doumeingts, J. Browne, M. Tomljanovich. Eds., Elsevier, Amsterdam, 593-600.
- Bause, F., Kritzinger, P. S., 1996. *Stochastic Petri Nets: An Introduction to the Theory*. Friedrich Vieweg & Sohn Verlag, Germany.
- Berthomieu, B., Diaz, M., 1991. Modelling and verification of time dependent systems. *IEEE Transactions Software Engineering*, 17(3), 259-273.
- Billington, J., Wheeler, G. R., Wilbur-Ham, M. C., 1988. PROTEAN: A high-level Petri Net tool for the specification and verification of communication protocols. *IEEE Transactions Software Engineering*, 14(3), 301-31.
- Bobbio, A., 1990. System modeling with Petri Nets. *System Reliability Assessment*, Kluwer p.c., Italy, 102-143.
- Cao, T., Sanderson, A. C., 1993. Variable reasoning and analysis about uncertainty with Fuzzy Petri Nets. *Proceedings 14th International Conference on Application and Theory of Petri Nets*, Troy, New York, 126-175.
- Cassandras, C. G., 1993. *Discrete event systems, Modeling and Performance Analysis*. Aksen Associates Inc., Homewood, IL.
- Chaudhury, A., Marinescu, D. C., Whinston, A., 1993. Net-based computational models of knowledge processing systems. *IEEE Expert*, 8, 79-86.
- Chehaibar, G., 1990. Validation of phase-executed protocols modeled with colored Petri

- Nets. Proceedings 11th International Conference on Application and Theory of Petri Nets, Paris, France, 84-103.
- Chen, S. M., Ke, J. S., Chang, J. F., 1990. Knowledge representation using Fuzzy Petri Nets. *IEEE Transactions on Knowledge and Data Engineering*, 2(3), 311– 319.
- Chock, G. Y. K., 2005. Modeling of hurricane damage for Hawaii residential construction. *Journal of Wind Engineering & Industrial Aerodynamics*, 93, 603–622.
- Cirado, G., Lindemann, C., 1993. Analysis of deterministic and Stochastic Petri Nets. Proceedings of the Fifth International Workshop on Petri Nets and Performance Models (PNPM93), Toulouse, France, 160-169.
- Collins, E., Simpson, L., 2007. The impact of climate change on insuring flood risk. Institute of Actuaries of Australia Biennial Convention, Christchurch, New Zealand.
- Committee on Earthquake Engineering (CoEE), 1989. Estimating losses from future earthquakes. *Earthquake Loss Estimation Methodology*. National Academy Press. Washington, D.C.
- Desrochers, A. A., 1992. Performance analysis using Petri Nets. *Journal of Intelligent and Robotic Systems*, 6, 65-79.
- Dudenhoeffer D., Permann, M., Manic, M., 2006. CIMS: A framework for infrastructure interdependency modeling and analysis. Proceedings of the 2006 Winter Simulation Conference, Monterey, CA, 478-485.
- Dunn, M., Wigert, I., 2004. International CIIP handbook 2004: an inventory and analysis of protection policies in fourteen countries. Swiss Federal Institute of Technology, Zurich.
- Ellingwood, B., Tekie, P. B., 2001. Fragility analysis of concrete gravity dams. *Journal of*

- Infrastructure Systems, 7(2), 41-48.
- FERC (Federal Energy Regulatory Commission), 1991. Engineering guidelines for evaluation of hydropower projects - Chapter III Gravity Dams. Federal Energy Regulatory Commission, Office of Hydropower Licensing, Report No. FERC 0119-2, Washington D.C., USA.
- Fiedrich, F., 2006. An HLA-based multiagent system for optimized resource allocation after strong earthquakes. Winter Simulation Conference, Monterey, 486-492.
- Filliben, J. J., Gurley, K., Pinelli, J. P., Simiu, E., 2002. Fragility curves, damage matrices, and wind induced loss estimation. 3rd International Conference on Computer Simulation in Risk Analysis & Hazard Mitigation, Sintra, Portugal, 119-126.
- Florin, G., Keiser, C., Natkin, S., 1989. Petri Net models of a distributed election protocol on unidirectional ring. Proceedings 10th International Conference on Application and Theory of Petri Nets, Bon, Germany, 154-173.
- Grinstead, C. M., Snell J. L., 1997. Introduction to probability. An online textbook, American Mathematical Society, USA.
- Gross, D., Harris C. M., 1998. Fundamentals of queuing theory. Wiley Series in Probability and Statistics, Wiley-Interscience, New York, NY.
- Guo, J., Chen, Z., 2008. Modeling infrastructure interdependencies using Fragility Curve analysis and Extended Petri Net. The Third World Congress on Engineering Asset Management and Intelligent Maintenance System Conference 2008 (WCEAM-IMS2008), CD-ROM, Beijing, China.
- Gursesli, O., Desrochers, A. A., 2003. Modeling infrastructure interdependencies using Petri Nets. IEEE, 1506-1512.

- Haimes, Y. Y., Horowitz, B. M., Lambert J. H., Santos, J. R., Lian, C., Crowther, K. G., 2005. Inoperability Input-Output Model for interdependent infrastructure sectors. *Journal of Infrastructure Systems*, 11, 67-79.
- Haimes, Y., Jiang P., 2001. Leontief-based model of risk in complex interconnected infrastructures. *Journal of Infrastructure Systems*, 7, 1-12.
- Hall, J. W., Dawson, R. J., Sayers, P. B., Rosu, C., Chatterton, J. B., Deakin, R., 2003. A methodology for national-scale flood risk assessment. *Proceedings of the Institution of Civil Engineers-Water and Maritime Engineering*, 156(3), 235-248.
- Howard, R. A., 1971. *Dynamic probabilistic systems*, John Wiley Sons, NY.
- Hoyt, J., 2004. Critical Infrastructure Protection (CIP) science and technology. *Technologies for Public Safety in Critical Incident Response Conference & Exposition 2004*, Homeland Security, New Orleans, LA.
- Huber, P., Pinci, V., 1991. A formal executable specification of the ISDN basic rate interface. *Proceedings 12th International Conference Application and Theory of Petri Nets*, Aarhus, Denmark, 1-21.
- Hura, G. S., 1987. Petri Net applications. *IEEE Potentials*, 6(3), 25-28.
- Hwang, H., Jernigan, J. B., Lin, Y. W., 2000. Evaluation of seismic damage to Memphis bridges and highway systems. *Journal of Bridge Engineering*, 5(4), 322-330.
- Hwang, H., Liu, J.B., Chiu, Y., 2001. Seismic fragility analysis of highway bridges. *Technical Report MAEC RR-4 Project*, Center for Earthquake Research and Information, University of Memphis.
- Jerath, K., 2002. Modeling and stochastic analysis of embedded systems emphasizing coincident failures, failure severity and usage-profiles. *Master Thesis*, Washington

State University, Washington.

Jiang, P., Haimes, Y. Y., 2004. Risk management for Leontief-based interdependent systems. *Risk Analysis*, 24(5), 1215-1229.

Karim, K.R., Yamazaki, F., 2000. Comparison of empirical and analytical fragility for RC bridge piers in Japan. *Proceedings of the 8th ASCE Specialty Conference on Probabilistic Mechanics and Structural Reliability*, Paper No. PMC2000-050, Reston, VA.

Karim, K., Yamazaki, F., 2003. A simplified method of constructing Fragility Curves for highway bridges. *Earthquake Engineering and Structural Dynamic*, 32(10), 1603-1623.

Kemeny, J. G., Snell, J. L., Thompson, G. L., 1974. *Introduction to finite mathematics*. 3<sup>rd</sup> edition, Englewood Cliffs, Prentice-Hall, NJ.

Kim, S., Shinozuka, M., 2004. Development of Fragility Curves of bridges retrofitted by column jacketing. *Probabilistic Engineering Mechanics*, 19(12), 105-112.

Krings, A., Oman, P., 2003. A simple GSPN for modeling common mode failures in critical infrastructures. *Proceedings of the 36th Hawaii International Conference on System Sciences*, Big Island, Hawaii, 9, 334a.

Kron, W., 2000. Invited lecture: Risk zonation and loss accumulation analysis for floods. *Stochastic Hydraulics and Hydrology*, 603-614.

Lakos, C. A., Keen, C. D., 1991. Modeling layered protocols in LOOP. *Proceedings 4th IEEE International Workshop on Petri Nets and Performance Models*, Melbourne, Australia, 106-115.

Linsley, R. K., Franzini J. B., 1992. *Water resources engineering*. McGraw-Hill, NY.



- Looney, C. G., 1988. Fuzzy Petri Nets for rule-based decision making. *IEEE Transactions on System, Man and Cybernetics*, 18(1), 178–183.
- Malla, S., Wieland, M., 1999. Analysis of an arch-gravity dam with a horizontal crack. *Computers & Structures*, 72, 267-278.
- Manson, P. R., 1988. Petri Net theory: a survey. Technical report, No. 139, University of Cambridge, Computer Laboratory, UK.
- Min, H. S. J., Beyeler, W., Brown, T., Son, Y. J., Jones, A. T., 2007. Toward modeling and simulation of critical national infrastructure interdependencies. *IIE Transactions*, 39, 57-71.
- Murata, T., 1989. Petri Nets: properties, analysis and applications. *Proceedings of the IEEE*, 77(4), 541-580.
- Neil, M., Fenton, N. E., Taylor, M., 2005. Using Bayesian Networks to model expected and unexpected operational losses. *Risk Analysis*, 25(4), 963-972.
- Newman, D. E., Nkei, B., Carreras, B. A., Dobson, I., Lynch, V. E., Gradney, P., 2005. Risk assessment in complex interacting infrastructure systems. *Proceedings of the 38th Annual Hawaii International Conference on System Sciences*, IEEE Press, Big Island, Hawaii, 2, 63c.
- North, M., 2000a. SMART II: the spot market agent research tool version 2.0 plus natural gas. Argonne National Laboratory, IL.
- North, M., 2000b. An agent-based tool for infrastructure interdependency policy analysis. Presentation at the Rand Workshop on Complex Systems and Policy Analysis: New Tools for a New Millennium, Washington, D.C.
- Norton, T., Abdullah, M., Stephens, D., 2008. Proposed methodology for performance

- based vulnerability assessment of wind-excited tall buildings. Proceedings of the Fourth International Conference on Advances in Wind and Structures (AWAS'08), Jeju, South Korea, 1228-1246.
- Office of Homeland Security, 2002. The national strategy for homeland security, Washington, D.C.
- O'Rourke, M. J., Eeri, M., So, P., 2000. Seismic Fragility Curves for on-grade steel tanks. Earthquake Spectra, 16(4), 801-815.
- Pederson, P., Dudenhoeffer, D., Hartley, S., Permann, M., 2006. Critical infrastructure interdependency modeling: A survey of U.S. and international research. Department of Energy, Critical Infrastructure Protection Division, Idaho National Laboratory (INL), Idaho Falls, Idaho.
- Peterson, J. L., 1977. Petri Nets. ACM Computing Surveys, 9(3), 223-252.
- Peterson, J. L., 1981. Petri Net theory and the modeling of systems. Prentice-Hall, Englewood Cliffs, NJ.
- Petri, C. A., 1962. Kommunikation mit Automaten. Ph.D. Thesis, Fakultät für Mathematik und Physik, Technische Hochschule Darmstadt, Darmstadt, Germany.
- President's Commission on Critical Infrastructure Protection, 1997. Critical Foundations – Protecting America's Infrastructures. Washington, D.C.
- Ramamoorthy, C. V., Dong, S. T., and Usuda, Y., 1987. An implementation of an automated protocol synthesizer (APS) and its application to the X.21 protocol. IEEE Transactions Software Engineering, 11(9), 886-908.
- Ramaswamy, S., Valavani, K. P., 1994. Modeling, analysis and simulation of failures in a materials handling system with extended Petri Nets. IEEE Transactions on Systems,

- Man, and Cybernetics, 24(9), 1358-1373.
- Ramchandani, C., 1974. Analysis of asynchronous concurrent systems by timed Petri Nets. TR-120, MIT, Cambridge, MA.
- Reed, D., Chang, S., McDaniels, T., 2006. Modeling of infrastructure interdependence. CRIS Third international Conference of Critical Infrastructures, Alexandria, VA.
- Rinaldi, S., Peerenboom, J., Kelly, T., 2001. Identifying, understanding, and analyzing critical infrastructure independencies. IEEE Control Systems Magazine, 21, 11-25.
- Shayan, A., Grimstad, J., 2006. Deterioration of concrete in a hydroelectric concrete gravity dam and its characterization. Cement and Concrete Research, 36, 371-383.
- Shinozuka, M., 2001. Fragility Curves for seismically retrofitted bridges and effect of retrofit on transportation network performance. MCEER Highway Project.
- Shinozuka, M., Feng, M., Kim, F., Uzaua, T., Ueda, T., 2003. Statistical analysis of Fragility Curves. Technical Report MCEER-03-0002, Department of Civil and Environmental Engineering, University of Southern California.
- Shinozuka, M., Feng, M. Q., Lee, J., Nagaruma, T., 2000. Statistical analysis of Fragility Curves. Journal of Engineering Mechanics, ASCE, 126(12), 1224-31.
- Simpson, D. M., Rockaway, T. D., Weigel, T. A., Coomes, P. A., Holloman, C. O., 2005. Framing a new approach to critical infrastructure modeling and extreme events. International Journal of Critical Infrastructures, 1 (2-3), 125-143.
- Singhal, A., Kiremidjian, A., 1996. Method for probabilistic evaluation of seismic structural damage. Journal of Structural Engineering, ASCE, 122(12), 1459-1467.
- Singal, A., Kiremidjian, A., 1998. Bayesian updating of fragilities with application to RC frames. Journal of Structural Engineering, ASCE, 124(8), 922-929.

- Sultana, S., Chen, Z., 2007. Modeling infrastructure interdependency among flood plain infrastructures with Extended Petri Net. Proceedings of the 16th IASTED International Conference on Applied Modeling and Simulation, Spain, 104-109.
- Suzuki, T., Shatz, S., Murata, T., 1990. A protocol modeling and verification approach based on specification language and Petri Nets. IEEE Transactions Software Engineering, 16(5), 523-536.
- Tantala, M.W., Deodatis, G., 2002. Development of seismic Fragility Curves for tall buildings. 15th ASCE Engineering Mechanics Conference, Columbia University, NY.
- The White House, 1998. The Clinton Administration's Policy on critical infrastructure protection: Presidential Decision Directive 63. Washington, D.C.
- Tomita, Y., Fukui, C., Kudo, H., 1998. Cooperative protection system with an agent model. IEEE Transactions on Power Delivery, 13, 1060-1066.
- Tsoukalas, L. H., Uluyol, O., 1999. Anticipatory agents for the deregulated electric power system. Workshop on Agent Simulation: Applications, Models, and Tools, University of Chicago, Chicago, 114-123.
- United States Congress, 2001. Uniting and Strengthening America by Providing Appropriate Tools Required to Intercept and Obstruct Terrorism (USA PATRIOT ACT) Act of 2001, Public Law, No. 107-56.
- US-Canada Power System Outage Task Force, 2004. Final report on August 14, 2003 blackout in the United States and Canada: causes and recommendations.
- U.S. Department of the Interior, 1973. Design of small dams. U.S. Government Printing Office, Washington.
- U.S. Department of the Interior, 1976. Design of gravity dams. U.S. Government Printing

Office, Denver.

- Wildberger, A. M., 1997. Modeling with independent intelligent agents for distributed control of the electric power grid. 59th Annual American Power Conference, Chicago, 361-364.
- Wildberger, A. M., 1998. Modeling the infrastructure industries as complex adaptive systems. Simulation International XV, San Diego, CA, 168-173.
- Xing, X., Ge, Y., Cheng, Q., Zuo, R., Liu, X., 2009. Geospatial complex structure simulation and analysis system of geological disasters using Petri Net. Journal of China University of Geosciences, 34(2), 381-386.
- Yamazaki, F., Hamada, T., Motoyama, H., Yamauchi, H., 1999. Earthquake damage assessment of expressway bridges in Japan. Technical Council on Lifeline Earthquake Engineering Monograph, 361-370.
- Zhou, M. C., McDermott, K., Patel, P. A., 1993. Petri Net synthesis and analysis of an FMS cell. IEEE Transactions System, Man, and Cybernetics, 23(2), 523-531.
- Zurawski, R., Dillon, T., 1991. Systematic construction of functional abstractions of Petri Net models of typical components of flexible manufacturing systems. Proceedings International Workshop on Petri Nets and Performance Models, Melbourne, Australia, 248-257.
- Zurawski, R., Zhou, M., 1994. Petri Nets and industrial applications: a tutorial. IEEE Transactions on Industrial Electronics, 41(6), 567-583.